

UNCLASSIFIED



**Issued by: National Security Agency  
Information Assurance Solutions  
Technical Directors**

**Disclaimer:**

This Information Assurance Technical Framework is the result of a collaborative effort by various organizations within the U.S. Government and industry. This document captures security needs and potential technology solutions for information systems and networks.

The information contained in this document is provided for information purposes only.

This is not a solicitation for procurement. Rather, this document is intended to facilitate the coordination of the information systems security needs of the U.S. Government and to offer security solution recommendations based on the collaborative efforts of the joint Industry/Government Information Assurance Technical Framework Forum.

UNCLASSIFIED

# REPORT DOCUMENTATION PAGE

Form Approved  
OMB No. 0704-0188

Public reporting burden for this collection of information is estimated to average 1 hour per response, including the time for reviewing instructions, searching existing data sources, gathering and maintaining the data needed, and completing and reviewing this collection of information. Send comments regarding this burden estimate or any other aspect of this collection of information, including suggestions for reducing this burden to Department of Defense, Washington Headquarters Services, Directorate for Information Operations and Reports (0704-0188), 1215 Jefferson Davis Highway, Suite 1204, Arlington, VA 22202-4302. Respondents should be aware that notwithstanding any other provision of law, no person shall be subject to any penalty for failing to comply with a collection of information if it does not display a currently valid OMB control number. **PLEASE DO NOT RETURN YOUR FORM TO THE ABOVE ADDRESS.**

<b>1. REPORT DATE (DD-MM-YYYY)</b> September 2002		<b>2. REPORT TYPE</b>		<b>3. DATES COVERED (From - To)</b>	
<b>4. TITLE AND SUBTITLE</b> Information Assurance Technical Framework (IATF) Release 3.1				<b>5a. CONTRACT NUMBER</b>	
				<b>5b. GRANT NUMBER</b>	
				<b>5c. PROGRAM ELEMENT NUMBER</b>	
<b>6. AUTHOR(S)</b>				<b>5d. PROJECT NUMBER</b>	
				<b>5e. TASK NUMBER</b>	
				<b>5f. WORK UNIT NUMBER</b>	
<b>7. PERFORMING ORGANIZATION NAME(S) AND ADDRESS(ES)</b> National Security Agency Information Assurance Solutions Technical Directors				<b>8. PERFORMING ORGANIZATION REPORT NUMBER</b>	
<b>9. SPONSORING / MONITORING AGENCY NAME(S) AND ADDRESS(ES)</b> National Security Agency Information Assurance Solutions Technical Directors				<b>10. SPONSOR/MONITOR'S ACRONYM(S)</b> NSA	
				<b>11. SPONSOR/MONITOR'S REPORT NUMBER(S)</b>	
<b>12. DISTRIBUTION / AVAILABILITY STATEMENT</b> Distribution Statement A: Approved for Public Release; Distribution is Unlimited.					
<b>13. SUPPLEMENTARY NOTES</b>					
<b>14. ABSTRACT</b> The Information Assurance Technical Framework (IATF) document was developed to help a broad audience of users both define and understand their technical needs as well as to select approaches to meet those needs. The intended audience includes system security engineers, customers, scientists, researchers, product and service vendors, standards bodies, and consortia. The objectives of the IATF include raising the awareness of information assurance (IA) technologies, presenting the IA needs of information system (IS) users, providing guidance for solving IA issues, and highlighting gaps between current IA capabilities and needs. Chapter 1 outlines the information infrastructure, the information infrastructure boundaries, the IA framework areas, and general classes of threats. It then introduces the Defense-in-Depth strategy and presents the overall organization of the IATF document.					
<b>15. SUBJECT TERMS</b>					
<b>16. SECURITY CLASSIFICATION OF:</b>			<b>17. LIMITATION OF ABSTRACT</b> UU	<b>18. NUMBER OF PAGES</b> 915	<b>19a. NAME OF RESPONSIBLE PERSON</b>
<b>a. REPORT</b> U	<b>b. ABSTRACT</b> U	<b>c. THIS PAGE</b> U			<b>19b. TELEPHONE NUMBER (include area code)</b>

**UNCLASSIFIED**

**Please review and provide comments.**

The Information Assurance Technical Framework is an evolving document. It will be expanded and updated. For these changes to be most beneficial, *your* comments and suggestions are needed. Please provide any comments or suggestions you care to make to:

IATF Manager

National Security Agency  
9800 Savage Road (SAB 3), Suite 6730  
Fort Meade, Maryland 20755-6730

Telephone: (410) 854-7302  
Fax: (410) 854-7508  
E-mail: [webmaster@iatf.net](mailto:webmaster@iatf.net)

# Foreword

---

The Information Assurance Technical Framework (IATF) document, Release 3.1, provides technical guidance for protecting the information infrastructures of the United States (U.S.) Government and industry. The information infrastructure processes, stores, and transmits information critical to the mission and business operations of an organization. This information is protected through information assurance (IA) that addresses all the security requirements of today's information infrastructure. IA relies on *people, operations*, and *technology* to accomplish the mission/business and to manage the information infrastructure. Attaining robust IA means implementing policies, procedures, techniques, and mechanisms at all layers of the organization's information infrastructure.

The IATF defines the information system security engineering (ISSE) process for developing a secure system. This process defines the principles, the activities, and the relationship to other processes. Applying these principles results in layers of protection known collectively as the Defense-in-Depth Strategy. The four major technology focus areas of the Defense-in-Depth Strategy are to Defend the Network and Infrastructure, Defend the Enclave Boundary, Defend the Computing Environment, and Defend Supporting Infrastructures.

The Defense-in-Depth Strategy has been broadly adopted. For example, within the U.S. Department of Defense (DoD), the Global Information Grid (GIG) IA Policy and Implementation Guidance was built around the strategy. This departmental-level policy document cites the IATF as a source of information on technical solutions and guidance for the DoD IA implementation.

The following content in the IATF has been updated in Release 3.1:

- Chapter 2, Defense-in-Depth, incorporates the major elements of the Defense-in-Depth Strategy.
- Chapter 3, Information Systems Security Engineering Process, refines the description of the Information Systems Security Engineer (ISSE) process.
- Chapter 7, Defend the Computing Environment, Section 7.1, Security for System Applications has been updated.
- A new appendix, Protection Needs Elicitation (PNE), has been added to detail the first and most important activity in the ISSE process.

The IATF is a living document; the next release already is being planned. Many people provided comments and recommendations on IATF Release 3.0; their comments helped define Release 3.1. Your suggestions, recommendations, and needs will define the next release—*if we hear from you*.

We want and need your feedback.

## UNCLASSIFIED

Foreword

IATF Release 3.1—September 2002

We ask that you send us your comments, reactions, criticism, recommended changes, noted omissions, and any suggestions that will make this document more useful to you. Please send your suggestions to [webmaster@iatf.net](mailto:webmaster@iatf.net). We also encourage you to visit the IATF Forum Web site (<http://www.iatf.net>) often. There you will be able to see the next release of the IATF unfolding, to review new and draft sections, to access contributor's resources, and, again, to give us your feedback. The objective of the IATF is to be a useful document *for you*. Please let us know how we did.

Recently, we have drafted Cooperative Research and Development Agreements (CRADA) for contributors who may prepare articles, papers, or other submissions for inclusion in the IATF. The CRADA is located on the contributor's page of the IATF Forum Web site.

On behalf of all the contributors of the Information Assurance Technical Framework—Release 3.1 and its predecessors—our thanks to the many people who reviewed and commented on the documents. Thanks also go to the many speakers and panelists of the IATF Forum sessions and the past Network Security Framework Forum sessions for sharing their valuable insights on the security architectures, standards, and solutions that industry and government are bringing to bear on the complex challenge of information assurance.

Cynthia Frederick  
IATF Technical Director

**TABLE OF CONTENTS**

**FOREWORD**..... iii

**LIST OF APPENDICES** ..... xiii

**LIST OF FIGURES**..... xv

**LIST OF TABLES** ..... xix

**EXECUTIVE SUMMARY**..... ES-1

**SUMMARY OF CHANGES** ..... 1

CHAPTER 1

**INTRODUCTION** ..... 1-1

    1.1 Objectives..... 1-1

    1.2 Intended Audiences ..... 1-2

    1.3 Context..... 1-2

        1.3.1 Information Infrastructures Defined..... 1-2

        1.3.2 Categorizing Information and Information Infrastructures ..... 1-3

        1.3.3 Boundaries and Information Infrastructures..... 1-5

        1.3.4 Information Assurance Framework Areas..... 1-6

        1.3.5 Nature of Cyber Threats ..... 1-11

    1.4 Defense-in-Depth ..... 1-14

        1.4.1 Defense-in-Depth and the IATF ..... 1-15

    1.5 IATF Organization ..... 1-15

CHAPTER 2

**DEFENSE IN DEPTH** ..... 2-1

    2.1 Introduction and Context Diagrams ..... 2-1

        2.1.1 Examples of User Environments..... 2-1

    2.2 Adversaries, Motivations, and Classes of Attack..... 2-4

    2.3 People, Technology, Operations..... 2-7

        2.3.1 People..... 2-7

        2.3.2 Technology..... 2-8

        2.3.3 Operations ..... 2-9

    2.4 Defense in Depth Objectives Overview ..... 2-9

    2.5 Additional Resources ..... 2-14

CHAPTER 3

**THE INFORMATION SYSTEMS SECURITY ENGINEERING PROCESS** ..... 3-1

- 3.1 Introduction ..... 3-1
- 3.2 Principles ..... 3-4
- 3.3 Process ..... 3-5
  - 3.3.1 Discover Information Protection Needs ..... 3-5
  - 3.3.2 Define System Security Requirements ..... 3-8
  - 3.3.3 Design System Security Architecture ..... 3-10
  - 3.3.4 Develop Detailed Security Design ..... 3-11
  - 3.3.5 Implement System Security ..... 3-12
  - 3.3.6 Assess Information Protection Effectiveness ..... 3-15
- 3.4 ISSE Relationship to Sample SE Processes ..... 3-16
- 3.5 Relationship of ISSE to DITSCAP ..... 3-17
- 3.6 Summary ..... 3-22

CHAPTER 4

**TECHNICAL SECURITY COUNTERMEASURES** ..... 4-1

- 4.1 Introduction ..... 4-1
- 4.2 Adversaries, Motivations, and Categories of Attacks ..... 4-2
  - 4.2.1 Potential Adversaries ..... 4-2
  - 4.2.2 Classes of Attack ..... 4-4
- 4.3 Primary Security Services ..... 4-10
  - 4.3.1 Access Control ..... 4-10
  - 4.3.2 Confidentiality ..... 4-18
  - 4.3.3 Integrity ..... 4-21
  - 4.3.4 Availability ..... 4-22
  - 4.3.5 Nonrepudiation ..... 4-23
- 4.4 Important Security Technologies ..... 4-24
- 4.5 Robustness Strategy ..... 4-30
  - 4.5.1 Overview of the General Process ..... 4-31
  - 4.5.2 Determining the Degree of Robustness ..... 4-32
  - 4.5.3 Strength of Mechanism ..... 4-34
  - 4.5.4 Level of Assurance ..... 4-45
  - 4.5.5 Examples of Process Application ..... 4-46
  - 4.5.6 Robustness Strategy Evolution ..... 4-52
  - 4.5.7 Real-World Applications ..... 4-53
- 4.6 Interoperability Framework ..... 4-53
  - 4.6.1 Major Elements of Interoperability ..... 4-54
  - 4.6.2 Challenges for Interoperability ..... 4-55
  - 4.6.3 Interoperability Strategy ..... 4-55

4.7 Key Management Infrastructure/ Public Key Infrastructure Considerations ..... 4-57  
 4.7.1 KMI/PKI Overview ..... 4-57  
 4.7.2 KMI/PKI Operational Services ..... 4-58  
 4.7.3 KMI/PKI Processes ..... 4-58

CHAPTER 5

**DEFEND THE NETWORK AND INFRASTRUCTURE ..... 5-1**

5.1 Availability of Backbone Networks ..... 5.1-1  
 5.1.1 Target Environment..... 5.1-1  
 5.1.2 Consolidated Requirements..... 5.1-5  
 5.1.3 Potential Attacks and Potential Countermeasures..... 5.1-8  
 5.1.4 Technology Assessment ..... 5.1-13  
 5.1.5 Framework Guidance ..... 5.1-17

5.2 Wireless Networks Security Framework..... 5.2-1  
 5.2.1 Cellular Telephone ..... 5.2-4  
 5.2.2 Low Earth Orbiting/Medium Earth Orbiting Satellite Telephone Networks ..... 5.2-16  
 5.2.3 Wireless Local Area Network ..... 5.2-22  
 5.2.4 Paging (One-Way and Two-Way)..... 5.2-31  
 5.2.5 Wireless Local Loop/Wireless Public Branch Exchange Cordless Telephones ..... 5.2-39

5.3 System-High Interconnections and Virtual Private Networks ..... 5.3-1  
 5.3.1 Target Environment..... 5.3-2  
 5.3.2 Consolidated Requirements..... 5.3-5  
 5.3.3 Potential Attacks ..... 5.3-7  
 5.3.4 Potential Countermeasures ..... 5.3-9  
 5.3.5 Technology Assessment ..... 5.3-10  
 5.3.6 Cases..... 5.3-22  
 5.3.7 Framework Guidance ..... 5.3-23

5.4 Security for Voice Over Internet Protocol (VoIP)..... 5.4-1  
 5.4.1 Target Environment..... 5.4-3  
 5.4.2 Requirements..... 5.4-4  
 5.4.3 Potential Attacks ..... 5.4-5  
 5.4.4 Potential Countermeasures ..... 5.4-7  
 5.4.5 Technology Assessment ..... 5.4-8  
 5.4.6 Cases..... 5.4-23  
 5.4.7 Framework Guidance ..... 5.4-25  
 5.4.8 Technology Gaps..... 5.4-26  
 5.4.9 Summary of Important Concepts..... 5.4-27

5.5 Multiple Security Layers ..... 5.5-1



**CHAPTER 6**

<b>DEFEND THE ENCLAVE BOUNDARY/EXTERNAL CONNECTIONS .....</b>	<b>6-1</b>
6.1 Firewalls .....	6.1-1
6.1.1 Target Environment.....	6.1-1
6.1.2 Firewall Requirements .....	6.1-2
6.1.3 Potential Attacks .....	6.1-4
6.1.4 Potential Countermeasures.....	6.1-6
6.1.5 Firewall Technology Assessment.....	6.1-10
6.1.6 Cases.....	6.1-19
6.1.7 Enclave Boundary Protection Framework Guidance .....	6.1-29
6.2 Remote Access .....	6.2-1
6.2.1 Target Environment.....	6.2-1
6.2.2 Consolidated Requirements.....	6.2-2
6.2.3 Potential Attacks .....	6.2-4
6.2.4 Potential Countermeasures .....	6.2-5
6.2.5 Technology Assessment.....	6.2-6
6.2.6 Cases.....	6.2-12
6.2.7 Framework Guidance .....	6.2-13
6.3 Guards .....	6.3-1
6.3.1 Target Environment.....	6.3-1
6.3.2 Requirements.....	6.3-3
6.3.3 Potential Attacks .....	6.3-5
6.3.4 Potential Countermeasures.....	6.3-7
6.3.5 Guard Technology Assessment .....	6.3-10
6.3.6 Selection Criteria.....	6.3-19
6.3.7 Framework Guidance .....	6.3-21
6.3.8 Technology Gaps.....	6.3-25
6.4 Network Monitoring Within Enclave Boundaries and External Connections .....	6.4-1
6.4.1 Network Intrusion Detection .....	6.4-2
6.4.2 Malicious Code (or Virus) Detectors .....	6.4-12
6.4.3 Discussion of Typical Bundling of Capabilities.....	6.4-16
6.4.4 Beyond Technology Solutions .....	6.4-17
6.4.5 For More Information.....	6.4-18
6.5 Network Scanners Within Enclave Boundaries .....	6.5-1
6.5.1 Network Vulnerability Scanners .....	6.5-1
6.5.2 War Dialers .....	6.5-6
6.5.3 Considerations for Deployment.....	6.5-10
6.5.4 Considerations for Operation .....	6.5-11
6.5.5 Discussion of Typical Bundling of Capabilities.....	6.5-11
6.5.6 Beyond Technology Solutions .....	6.5-12
6.5.7 For More Information.....	6.5-12
6.6 Malicious Code Protection .....	6.6-1
6.6.1 Target Environment.....	6.6-2

6.6.2	Malicious Code Protection Requirements.....	6.6-3
6.6.3	Potential Attack Mechanisms.....	6.6-4
6.6.4	Potential Countermeasures.....	6.6-6
6.6.5	Technology Assessment.....	6.6-11
6.6.6	Selection Criteria.....	6.6-22
6.6.7	Cases.....	6.6-23
6.6.8	Framework Guidance.....	6.6-25
6.7	Multilevel Security.....	6.7-1
6.7.1	High-to-Low.....	6.7-1
6.7.2	MLS Workstation.....	6.7-23
6.7.3	MLS Servers.....	6.7-23
6.7.4	MLS Network Components.....	6.7-23

## CHAPTER 7

<b>DEFEND THE COMPUTING ENVIRONMENT.....</b>	<b>7-1</b>
7.1 Security for System Applications.....	7.1-1
7.1.1 Target Environment.....	7.1-1
7.1.2 Consolidated Requirements.....	7.1-5
7.1.3 Potential Attacks.....	7.1-6
7.1.4 Potential Countermeasures.....	7.1-8
7.1.5 Technology Assessment.....	7.1-11
7.1.6 Cases.....	7.1-21
7.1.7 Framework Guidance.....	7.1-23
7.2 Detect and Respond Capabilities Within Host-Based Computing Environments....	7.2-1
7.2.1 Host Monitors—Intrusion Detection.....	7.2-2
7.2.2 Host Monitors—Malicious Code or Virus Detectors.....	7.2-13
7.2.3 Host Vulnerability Scanners.....	7.2-17
7.2.4 File Integrity Checkers.....	7.2-23
7.2.5 Typical Bundling of Capabilities Within Products.....	7.2-27
7.2.6 Beyond Technology Solutions.....	7.2-27
7.2.7 For More Information.....	7.2-29

## CHAPTER 8

<b>SUPPORTING INFRASTRUCTURE.....</b>	<b>8-1</b>
8.1 Key Management Infrastructure/ Public Key Infrastructure.....	8.1-1
8.1.1 KMI/PKI Introduction.....	8.1-1
8.1.2 Certificate Management.....	8.1-11
8.1.3 Symmetric Key Management.....	8.1-35
8.1.4 Infrastructure Directory Services.....	8.1-39
8.1.5 Infrastructure Management.....	8.1-48
8.1.6 KMI/PKI Assurance.....	8.1-70
8.1.7 KMI/PKI Solutions.....	8.1-71

UNCLASSIFIED

Table of Contents  
IATF Release 3.1—September 2002

8.1.8 Future Trends of Public Key Infrastructure..... 8.1-102  
8.2 Detect and Respond as a Supporting Element..... 8.2-1  
8.2.1 What This Focus Area Addresses ..... 8.2-1  
8.2.2 Enterprise Architecture Considerations..... 8.2-2  
8.2.3 General Considerations for a Detect and Respond Solution ..... 8.2-5  
8.2.4 Detect and Respond Functions ..... 8.2-8  
8.2.5 Relevant Detect and Respond Technologies ..... 8.2-19  
8.2.6 For More Information..... 8.2-38

CHAPTER 9

**INFORMATION ASSURANCE FOR THE TACTICAL ENVIRONMENT..... 9-1**  
9.1 Target Environment..... 9-2  
9.2 Wiping Classified Data From Tactical Equipment ..... 9-8  
9.2.1 Mission Need..... 9-8  
9.2.2 Consolidated Requirements..... 9-10  
9.2.3 Technology Assessment ..... 9-10  
9.2.4 Framework Guidance ..... 9-11  
9.3 Stored Data Protection in a Hostile Environment ..... 9-11  
9.3.1 Mission Need..... 9-12  
9.3.2 Consolidated Requirements..... 9-13  
9.3.3 Technology Assessment ..... 9-13  
9.3.4 Framework Guidance ..... 9-14  
9.4 Key Management in a Tactical Environment ..... 9-14  
9.4.1 Mission Need..... 9-14  
9.4.2 Consolidated Requirements..... 9-16  
9.4.3 Technology Assessment ..... 9-16  
9.4.4 Framework Guidance ..... 9-18  
9.5 Network Mobility/Dynamic Networks ..... 9-18  
9.5.1 Mission Need..... 9-19  
9.5.2 Consolidated Requirements..... 9-20  
9.5.3 Technology Assessment ..... 9-21  
9.5.4 Framework Guidance ..... 9-23  
9.6 Access to Individual Classified Accounts by Multiple Users ..... 9-24  
9.6.1 Mission Need..... 9-25  
9.6.2 Consolidated Requirements..... 9-25  
9.6.3 Technology Assessment ..... 9-26  
9.6.4 Framework Guidance ..... 9-27  
9.7 Secure Net Broadcast and Multicast ..... 9-28  
9.7.1 Mission Need..... 9-28  
9.7.2 Consolidated Requirements..... 9-28  
9.7.3 Technology Assessment ..... 9-29  
9.7.4 Framework Guidance ..... 9-31

**UNCLASSIFIED**

9.8 IA Solutions in Low Bandwidth Communications ..... 9-31

    9.8.1 Mission Need..... 9-31

    9.8.2 Consolidated Requirements..... 9-32

    9.8.3 Technology Assessment ..... 9-32

    9.8.4 Framework Guidance ..... 9-34

9.9 Split-Base Operations..... 9-34

    9.9.1 Mission Need..... 9-37

    9.9.2 Consolidated Requirements..... 9-37

    9.9.3 Technology Assessment ..... 9-38

    9.9.4 Framework Guidance ..... 9-39

9.10 Multi-Level Security ..... 9-39

    9.10.1 Mission Need..... 9-40

    9.10.2 Consolidated Requirements..... 9-40

    9.10.3 Technology Assessment ..... 9-41

    9.10.4 Framework Guidance ..... 9-42

9.11 Additional Technologies ..... 9-42

CHAPTER 10

**A VIEW OF AGGREGATED SOLUTION ..... 10-1**

**UNCLASSIFIED**

Table of Contents  
IATF Release 3.1—September 2002

**This page intentionally left blank.**

**LIST OF APPENDICES**

APPENDIX A — **ACRONYMS** ..... A-1

APPENDIX B — **GLOSSARY** ..... B-1

APPENDIX C — **CHARACTERIZATION OF CUSTOMER COMMUNITY NETWORKS** C-1

APPENDIX D — **SYSTEM SECURITY ADMINISTRATION** ..... D-1

APPENDIX E — **OFFICE OF THE SECRETARY OF DEFENSE INFORMATION  
ASSURANCE POLICY ROBUSTNESS LEVELS**..... E-1

APPENDIX F — **EXECUTIVE SUMMARIES** ..... F-1

APPENDIX G — **PROTECTION PROFILES** ..... G-1

APPENDIX H — **PROTECTION NEEDS ELICITATION**..... H-1

APPENDIX I — **MISSION-ORIENTED RISK ANALYSIS** ..... I-1

APPENDIX J — **ISSE RELATIONSHIP TO SAMPLE SE PROCESSES** ..... J-1

**UNCLASSIFIED**

List of Tables  
IATF Release 3.1—September 2002

**This page intentionally left blank.**

**LIST OF FIGURES****Chapter 1**

Figure 1-1.	Availability and Protection to Information.....	1-4
Figure 1-2.	Information Infrastructure Elements .....	1-5
Figure 1-3.	IA Technology Framework Access .....	1-6
Figure 1-4.	Local Computing Environment Area .....	1-7
Figure 1-5.	Enclave Boundaries Framework Area.....	1-8
Figure 1-6.	Network and Infrastructure Framework Structure.....	1-10
Figure 1-7.	Classes of Attacks on the Information Infrastructure.....	1-13
Figure 1-8.	Principal Aspects of the Defense-in-Depth .....	1-14
Figure 1-9.	Composition of the IATF .....	1-16

**Chapter 2**

Figure 2-1.	Federal Computing Environment—DOE.....	2-2
Figure 2-2.	Federal Computing Environment—DoD .....	2-4
Figure 2-3.	Classes of Attacks on the Information Infrastructure.....	2-6
Figure 2-4.	Defense in Depth Strategy.....	2-7
Figure 2-5.	Defense in Depth Strategy—People.....	2-8
Figure 2-6.	Defense in Depth Strategy—Technology.....	2-8
Figure 2-7.	Defense in Depth Strategy—Operations .....	2-9
Figure 2-8.	Defense in Depth Focus Areas .....	2-11

**Chapter 3**

Figure 3-1.	Generic Systems Engineering Process .....	3-2
Figure 3-2.	Discover Needs .....	3-7
Figure 3-3.	Allocation of Needs into a Solution Set.....	3-8
Figure 3-4a.	Define System Requirements .....	3-10
Figure 3-4b.	Design System Architecture.....	3-10
Figure 3-5.	DoD 5000.2-R Systems Engineering Process .....	3-17
Figure 3-6.	IEEE Std 1220-1998 Systems Engineering Process.....	3-18
Figure 3-7.	Relationship of SE/ISSE and C&A.....	3-19

**Chapter 4**

Figure 4-1.	Categories of Attacks Against Networked Systems.....	4-5
-------------	--	-----

**Chapter 5**

Figure 5-1.	Defend the Network and Infrastructure.....	5-2
Figure 5.1-1.	Backbone Availability Model .....	5.1-3



UNCLASSIFIED

List of Figures  
IATF Release 3.1—September 2002

Figure 5.2-1. Wireless Extension of the Wired Infrastructure ..... 5.2-4

Figure 5.2-2. Cellular Telephone Environment ..... 5.2-6

Figure 5.2-3. Mobile Satellite Subscriber Environment ..... 5.2-17

Figure 5.2-4. WLAN Environment ..... 5.2-23

Figure 5.2-5. Pager Environment ..... 5.2-33

Figure 5.2-6. Wireless Telephony Environments ..... 5.2-41

Figure 5.3-1. Target Environment Communications Infrastructure..... 5.3-2

Figure 5.3-2. Local Virtual Private Network Architectures..... 5.3-5

Figure 5.3-3. IP Layering Encryption Methods..... 5.3-16

Figure 5.3-4. Reverse Tunneling Placement of Cryptographic Mechanisms..... 5.3-19

Figure 5.4-1. SIP Network ..... 5.4-10

Figure 5.4-2. Relationship Between Media Gateway Control Protocol  
and H.323 or SIP ..... 5.4-15

Figure 5.4-3. Voice over ATM ..... 5.4-16

Figure 5.4-4. Voice over Frame Relay ..... 5.4-17

Figure 5.4-5. Integrating a VoIP Capability onto an Existing Network..... 5.4-24

**Chapter 6**

Figure 6-1. Defend the Enclave Boundary ..... 6-2

Figure 6.1-1. Enclave Boundary Environment..... 6.1-2

Figure 6.1-2. Application Gateway ..... 6.1-14

Figure 6.1-3. Dual-Homed Firewall Architecture..... 6.1-15

Figure 6.1-4. Screened Host Firewall Architecture ..... 6.1-16

Figure 6.1-5. Screened Subnet Firewall Architecture ..... 6.1-17

Figure 6.1-6. Case 1—Private to Public Network Communication..... 6.1-19

Figure 6.1-7. Case 2—Remotely Accessing a Private Network ..... 6.1-22

Figure 6.1-8. Case 3—Private Network Connectivity via a Lower-Level Network..... 6.1-24

Figure 6.1-9. Case 4—Collaborative LAN’s with Public Network Connections..... 6.1-26

Figure 6.2-1. Typical Remote Access Environment ..... 6.2-2

Figure 6.2-2. Attacks Against the Remote Access Scenario..... 6.2-4

Figure 6.2-3. Security Technologies in the Remote Access Scenario ..... 6.2-7

Figure 6.2-4. Protocol Layers In Remote Access Scenario..... 6.2-9

Figure 6.2-5. Remote Access Cases..... 6.2-13

Figure 6.3-1. Guard Environment..... 6.3-2

Figure 6.3-2. Dual Network Approach ..... 6.3-11

Figure 6.3-3. Cascading Protection..... 6.3-19

Figure 6.3-4. File Transfers..... 6.3-22

Figure 6.3-5. Secret to Unclassified Releasability..... 6.3-23

Figure 6.3-6. Human Reviewer-Man in the Middle..... 6.3-24

Figure 6.3-7.	Releasability Human Verification .....	6.3-24
Figure 6.4-1.	Breakdown of Network Monitor Technologies.....	6.4-1
Figure 6.4-2.	Network IDS Deployment Options .....	6.4-11
Figure 6.5-1.	Back-Door Attacks Through Telephone Networks.....	6.5-7
Figure 6.6-1.	Malicious Code Relationship .....	6.6-1
Figure 6.6-2.	Sources of Malicious Code Infections.....	6.6-2
Figure 6.6-3.	Virus Execution.....	6.6-12
Figure 6.6-4.	Logic Bomb Execution.....	6.6-15
Figure 6.6-5.	Virus Filter .....	6.6-18
Figure 6.6-6.	DOS File Infection .....	6.6-20
Figure 6.6-7.	Intelligent Scanning Architecture (ISA).....	6.6-22
Figure 6.6-8.	Macro Virus Infection .....	6.6-23
Figure 6.6-9.	Polymorphic Virus Infection .....	6.6-24
Figure 6.6-10.	Trojan Horse Infection .....	6.6-25
Figure 6.7-1.	High-to-Low Concepts .....	6.7-1
Figure 6.7-2.	Recommended Topology .....	6.7-21

## Chapter 7

Figure 7-1.	Local Computing Environments .....	7-1
Figure 7.1-1.	Custom N-Tier Applications .....	7.1-17
Figure 7.2-1.	Breakdown of Host Sensor Technologies .....	7.2-1

## Chapter 8

Figure 8-1.	Supporting Infrastructures: KMI/PKI.....	8-2
Figure 8-2.	Supporting Infrastructures: Detect and Respond.....	8-4
Figure 8.1-1.	Interactions of the KMI/PKI Applications Operational Services.....	8.1-7
Figure 8.1-2.	Using PKIs in Secure Enclaves .....	8.1-12
Figure 8.1-3.	Hierarchical, Trust List, and Mesh Approaches to PKI Interoperation.....	8.1-13
Figure 8.1-4.	Bilateral Cross-Certification, Bridge CA, and Online Status Approaches to PKI Interoperation .....	8.1-14
Figure 8.1-5.	Browser Certification: Key Generation and Certificate Request .....	8.1-22
Figure 8.1-6.	Browser Certification: CA Processing Request .....	8.1-23
Figure 8.1-7.	S/MIME Client Certification Process .....	8.1-25
Figure 8.1-8.	Browser Certification: Installing Certificate in Browser.....	8.1-27
Figure 8.1-9.	Critical Elements of Symmetric Key Management Activities .....	8.1-35
Figure 8.1-10.	Directory Model .....	8.1-40
Figure 8.1-11.	Directory Use Access .....	8.1-41
Figure 8.1-12.	Key Management Infrastructure Directory Information Tree .....	8.1-43
Figure 8.1-13.	Access Control Decision Function Required for Access Control .....	8.1-45

UNCLASSIFIED

List of Figures  
IATF Release 3.1—September 2002

Figure 8.1-14. DoD Class 3 PKI Architecture ..... 8.1-57

Figure 8.1-15. FORTEZZA CMI Components..... 8.1-75

Figure 8.1-16. Operational Activities Supported by the KMI..... 8.1-78

Figure 8.1-17. DoD KMI System Context..... 8.1-84

Figure 8.1-18. Nodal View of the Target KMI ..... 8.1-85

Figure 8.1-19. Breakdown of Client Nodes ..... 8.1-85

Figure 8.1-20. Federal PKI Architecture..... 8.1-95

Figure 8.2-1. Perspectives of Layers in a Detect and Respond Infrastructure Hierarchy ... 8.2-6

Figure 8.2-2. Basic Hierarchy for Detect and Respond Infrastructure..... 8.2-7

Figure 8.2-3. Basic View of Detect and Respond Phases ..... 8.2-9

Figure 8.2-4. Realistic View of Detect and Respond Phases..... 8.2-10

Figure 8.2-5. Possible Allocations of Detect and Respond Functions..... 8.2-11

Figure 8.2-6. Functions to Support Warning ..... 8.2-12

Figure 8.2-7. Functions to Support Local Incident Detection..... 8.2-13

Figure 8.2-8. Functions to Support Incident Characterization..... 8.2-14

Figure 8.2-9. Functions to Support Incident Response ..... 8.2-15

Figure 8.2-10. Functions to Support Attack Determination..... 8.2-16

Figure 8.2-11. Functions to Support Attack Characterization ..... 8.2-17

Figure 8.2-12. Functions to Support Response Coordination..... 8.2-18

Figure 8.2-13. Functions to Support Attack Investigation..... 8.2-19

Figure 8.2-14. Detect and Respond Technologies ..... 8.2-21

Figure 8.2-15. Sensor Technologies Grouping ..... 8.2-22

Figure 8.2-16. Possible Sensor Deployment Locations ..... 8.2-25

Figure 8.2-17. Detect and Respond Technology Reference Model ..... 8.2-37

**Chapter 9**

Figure 9-1. Tactical Communications Environment..... 9-3

Figure 9-2. Tactical Communications Information Flow ..... 9-4

Figure 9-3. Interconnecting Cell Sites Using a UAV..... 9-30

Figure 9-4. Near-Term Architecture ..... 9-36

Figure 9-5. Objective WIN Security Architecture ..... 9-36

Figure 9-6. Battlefield Video Teleconference..... 9-44

## LIST OF TABLES

**Chapter 1**

Table 1-1.	Classes of Attack.....	1-11
------------	------------------------	------

**Chapter 2**

Table 2-1.	Classes of Attack.....	2-5
Table 2-2.	Examples of Layered Defenses .....	2-13

**Chapter 3**

Table 3-1.	Corresponding SE and ISSE Activities.....	3-3
Table 3-2.	Assess Information Protection Effectiveness Tasks by ISSE Activity.....	3-15

**Chapter 4**

Table 4-1.	Potential Adversaries.....	4-3
Table 4-2.	Examples of Passive Attacks.....	4-6
Table 4-3.	Examples of Active Attacks.....	4-6
Table 4-4.	Examples of Close-In Attacks.....	4-8
Table 4-5.	Examples of Insider Attacks.....	4-9
Table 4-6.	Examples of Distribution Attacks .....	4-10
Table 4-7.	Degree of Robustness.....	4-32
Table 4-8.	Security Management Mechanisms.....	4-36
Table 4-9.	Confidentiality Mechanisms.....	4-37
Table 4-10.	Integrity Mechanisms .....	4-38
Table 4-11.	Availability Mechanisms.....	4-40
Table 4-12.	I&A Mechanisms .....	4-41
Table 4-13.	Access Control Mechanisms .....	4-42
Table 4-14.	Accountability Mechanisms .....	4-43
Table 4-15.	Nonrepudiation Mechanisms.....	4-44
Table 4-16.	Example Assessment Using Degree of Robustness Table .....	4-48
Table 4-17.	Application of Confidentiality Mechanisms Table for Example One.....	4-49
Table 4-18.	Use of Security Management Mechanisms Table .....	4-50
Table 4-19.	Example Assessment Using Degree of Robustness Table .....	4-51

**Chapter 5**

Table 5.3-1.	Digital Service Standards .....	5.3-3
Table 5.3-2.	Characteristics of Layer 2 Protected Networks .....	5.3-11
Table 5.3-3.	Characteristics of Layer-3-Protected Networks .....	5.3-14

**Chapter 6**

Table 6.2-1a. Summary Guidance for Remote Access  
Direct Dial-up Access to Secret Enclave ..... 6.2-14

Table 6.2-1b. Summary Guidance for Remote Access  
Direct Dial-up Access to Secret Enclave ..... 6.2-15

Table 6.2-1c. Summary Guidance for Remote Access  
Direct Dial-Up Access to Secret Enclave ..... 6.2-16

Table 6.2-1d. Summary Guidance for Remote Access  
Direct Dial-up Access to Secret Enclave ..... 6.2-17

Table 6.4-1. Network-Based IDS Considerations ..... 6.4-5

Table 6.6-1. Comparison of Macro Viruses ..... 6.6-13

**Chapter 7**

Table 7.1-1. Pros and Cons of GSS-API ..... 7.1-15

Table 7.1-2. Pros and Cons of CDSA..... 7.1-15

Table 7.1-3. Pros and Cons of Cryptoki (PKCS #11)..... 7.1-15

Table 7.2-1. Host-Based IDS Considerations ..... 7.2-6

Table 7.2-2. File Integrity Checker Considerations ..... 7.2-24

**Chapter 8**

Table 8.1-1. KMI/PKI Services Support to Subscriber Categories ..... 8.1-1

Table 8.1-2. Security Applications Supported By Cryptographic Type ..... 8.1-3

Table 8.1-3. KMI/PKI Processes ..... 8.1-5

Table 8.1-4. Attacks and Countermeasures ..... 8.1-10

Table 8.1-5. Business Requirement and Security Technology Comparison..... 8.1-96

# Executive Summary

---

## Chapter 1—Introduction

The Information Assurance Technical Framework (IATF) document was developed to help a broad audience of users both define and understand their technical needs as well as to select approaches to meet those needs. The intended audience includes system security engineers, customers, scientists, researchers, product and service vendors, standards bodies, and consortia. The objectives of the IATF include raising the awareness of information assurance (IA) technologies, presenting the IA needs of information system (IS) users, providing guidance for solving IA issues, and highlighting gaps between current IA capabilities and needs. Chapter 1 outlines the information infrastructure, the information infrastructure boundaries, the IA framework areas, and general classes of threats. It then introduces the Defense-in-Depth strategy and presents the overall organization of the IATF document.

## Chapter 2—Defense-in-Depth Overview

When developing an effective IA posture, all three components of the Defense-In-Depth strategy—people, technology, and operations—need to be addressed. This framework document focuses primarily on the technology aspects of Defense-in-Depth. The technology objectives and approaches explained in the sections that follow, focus on the needs of the private, public, civil, and military sectors of our society.

Chapter 2 provides an overview of the Defense-in-Depth technology objectives and gives two examples of federal computing environments. The Defense-in-Depth objectives are organized around the four Defense-in-Depth technology focus areas:

- Defend the Network and Infrastructure
  - Availability of backbone networks
  - Wireless Networks Security Framework
  - System high interconnections and virtual private networks (VPN).
- Defend the Enclave Boundary
  - Protection for network access
  - Remote access
  - Multilevel security.
- Defend the Computing Environment
  - End-user environment
  - Security for system applications.
- Supporting Infrastructures
  - Key Management Infrastructure/Public Key Infrastructure (KMI/PKI)
  - Detect and respond.

## **Chapter 3—Information Systems Security Engineering Process**

Chapter 3 describes the systems engineering (SE) and information systems security engineering (ISSE) processes. The ISSE process is presented as a natural extension of the systems engineering process. The two processes share common elements: discovering needs, defining system functionality, designing system elements, producing and installing the system, and assessing the effectiveness of the system. Other systems processes—systems acquisition, risk management, certification and accreditation, and life-cycle support processes—are explained in relation to the ISSE process. Chapter 3 also provides suggestions on how the Common Criteria might be used to support the ISSE process. The processes described in this chapter provide the basis for the background information, technology assessments, and guidance contained in the remainder of the IATF document. An appendix, Protection Needs Elicitation (PNE), elaborates on the discover needs section of the chapter. This appendix provides a description of the process of determining or eliciting from customers their information protection needs.

## **Chapter 4—Technical Security Countermeasures**

This chapter of the IATF provides the background for detailed technical discussions contained in later sections of the IATF. It presents a general discussion of the principles for determining appropriate technical security countermeasures. The chapter includes a detailed description of threats, including attacker motivations, information security services, and appropriate security technologies. Through use of the methodology described in Chapter 3, Information Systems Security Engineering Process, assessment of threats to the information infrastructure results in the identification of vulnerabilities followed by a managed approach to mitigating risks. Chapter 4 explains how primary security mechanisms, the robustness strategy, interoperability, and KMI/PKI should be considered in the selection of security countermeasures, technology, and mechanisms. These decisions form the basis for developing appropriate technical countermeasures for the identified threats, based on the value of the information.

## **Chapter 5—Defend the Network and Infrastructure**

Chapter 5 describes the Defend the Network and Infrastructure technology focus area of the Defense-in-Depth strategy. The chapter describes the types of network traffic—user, control, and management—and the basic requirements to ensure that network services remain both available and secure. Organizations that operate networks should defend their networks and the infrastructures that support their networks by establishing clear service level agreements (SLA) with their commercial carriers that specify metrics for reliability, priority, and access control. Organizations must recognize that their data may be unprotected during transmission and take additional steps. Chapter 5 describes current strategies for defending networks (including data, voice, and wireless networks) and the corresponding network infrastructures.

## **Chapter 6—Defend the Enclave Boundary/External Connections**

Defense of the enclave boundary in Chapter 6 focuses on effective control and monitoring of the data flows into and out of the enclave. Effective control measures include firewalls, guards,

VPNs, and identification and authentication (I&A)/access control for remote users. Effective monitoring mechanisms include network-based intrusion detection systems (IDS), vulnerability scanners, and virus detectors located on the local area network (LAN). These mechanisms work alone, and in concert with each other to provide defenses for those systems within the enclave. Although the primary focus of boundary protection is on protecting the inside from the outside, protected enclave boundaries also use technology and mechanisms to protect against malicious insiders who use the enclave to launch attacks or who facilitate outsider access through open doors or covert channels. The technologies discussed in Chapter 6 include firewalls, guards, virus/malicious code detection systems, IDSs, and multilevel security systems. The IA strategy for defending an enclave boundary should flexibly implement those policies governing communications between secure enclaves and between secure enclaves and external systems. The IA strategy must also provide the management capabilities for verifying compliance with policies governing defense of the enclave boundary.

## **Chapter 7—Defend the Computing Environment**

Chapter 7 discusses the third technology focus area of the Defense-in-Depth strategy, Defend the Computing Environment. The computing environment includes the end-user workstation—both desktop and laptop—including peripheral devices. Servers include application, network, Web, file, and internal communication servers. A fundamental tenet of the Defense-in-Depth strategy is preventing cyber attacks from penetrating networks and compromising the confidentiality, integrity, and availability of the computing environment information. For those attacks that do succeed, early detection and effective response are essential to mitigating the effects of the attacks. Intrusion detection, network scanning, and host scanning are the measurement functions that, on a continuous or periodic basis, determine the effectiveness of the deployed protection systems. Chapter 7 also addresses host-based sensors, including those that operate in near real time as well as those that operate off-line.

## **Chapter 8—Supporting Infrastructures**

Supporting Infrastructures is the fourth technology focus area of the Defense-in-Depth strategy. The IATF addresses two supporting infrastructure entities: KMI/PKI and Detect and Respond. KMI/PKI focuses on the technologies, services, and processes used to manage public key certificates and symmetric cryptography. The discussion concludes with recommendations for the features needed to achieve the three global information grid-defined assurance levels: basic, medium, and high. The Detect and Respond section of Chapter 8 addresses providing warnings, detecting and characterizing suspected cyber attacks, coordinating effective responses, and performing investigative analyses of attacks.

## **Chapter 9—Information Assurance for the Tactical Environment**

The tactical environment, in which military or military-style operations are conducted, presents unique IA challenges. In this operational environment, there is heavy reliance on the communication of urgent, time-sensitive, or life-and-death information, often over wireless links. In the past, tactical communications equipment primarily consisted of government off-the-shelf



(GOTS) equipment. Decreased budgets and increased interoperability requirements in today's military organizations have led to the increased use of commercially developed equipment in tactical communications. Included in this use of commercial equipment is the use of commercial wireless networks and equipment in the tactical environment. Chapter 9 discusses the IA needs of the tactical environment, highlighting key tactical issues and identifying the associated security implications.

## **Chapter 10—A View of Aggregated Solutions**

This section of the framework is included in recognition of the fact that the needs of most users are represented not by any single technology focus area, but by some combinations of them. A future release of the framework will include a discussion of developing and evaluating security approaches that are aggregations of the recommendations from the individual categories.

### **In Closing...**

This framework document is principally intended as a reference document to provide insight and guidance to security managers and system security engineers on how to address the IA concerns of their organizations. It is tutorial (rather than prescriptive) in nature in recognition of the fact that many organizations face unique challenges that don't lend themselves to "one size fits all" solutions. This document offers insights intended to help improve the community awareness of the tradeoffs among available solutions (at a technology, not a product level) and of the desired characteristics of IA approaches for particular problems. While this framework attempts to lay out a large amount of information in an orderly sequence, it is structured to allow readers to use the table of contents to find topics of interest.

# Summary of Changes

---

As of September 2002

This section summarizes the changes that have been made to the framework document with each release, beginning with today's IATF Release 3.1 through the initial draft Network Security Framework (NSF) documents.

In general, with each release spelling errors are corrected and editing, formatting, and punctuation changes are made. Internet URLs and acronyms are reviewed and updated as required. Framework sections are selectively updated or new sections are added. Figures are reviewed and redrawn as needed.

## Changes in IATF Release 3.1—September 2002

- Expanded on Chapter 2, Defense-in-Depth Overview, to include a new introduction highlighting the Information Assurance (IA) strategy, which focused on the following areas: adversaries, motivations, classes of attacks, and IA. The IA section of the introduction covers the importance of people, technology, and operations.
- Reorganized Chapter 3, to emphasize the three important System Engineering (SE) principles and to separate sections on each of the SE and Information Systems Security Engineering (ISSE) activities.
- Expanded on Chapter 3, Information Systems Security Engineering Process, by including a new appendix elaborating on the Discover Needs section of the chapter. The appendix provides a description of the process of determining or eliciting from customers their information protection needs, hence the appendix is titled Protection Needs Elicitation (PNE).
- Added new Section 5.4, Security for Voice Over Internet Protocol (IP).
- Revised Chapter 7, Defending the Computing Environment, with major updates to Section 7.1, Security for System Applications.

## Changes in IATF Release 3.0—September 2000

- Expanded the document beyond the Department of Defense (DoD) by “nationalizing” its presentation and content.
- Revised Chapter 1, Introduction, and Chapter 2, Defense-in-Depth Objectives Overview, to directly focus on the Defense-in-Depth strategy's approach to IA.
- Expanded and renamed Chapter 3, Information Systems Security Engineering Process, to address SE, systems acquisition, risk management, certification and accreditation (C&A), and life-cycle support and to show how these methodologies relate to the ISSE activities.

## UNCLASSIFIED

Summary of Changes  
IATF Release 3.1—September 2002

- Reconfigured Chapter 4 to address the common technical issues of adversaries (and how adversaries act) and to provide a discussion of the primary security services. Adversaries, Threat (Motivations/Capabilities), and Attacks (IATF 2.0.1, Section 3.2.2) became elements of Chapter 4.
- Expanded and modified Chapter 6, Defend the Enclave Boundary/External Connections as follows:
  - Added Sections 6.4, Network Monitoring Within Enclave Boundaries and External Connections; 6.5, Network Scanners Within Enclave Boundaries; and 6.6, Malicious Code Protection.
  - Revised Sections 6.1, Firewall, and 6.3, Guards.
  - Moved Section 6.3, Multi-Level Security to Section 6.7.
- Added new Section 7.2, Host-Based Detect and Respond Capabilities Within Computing Environments.
- Updated Chapter 8, Supporting Infrastructure, to include both a comprehensive description of what constitutes the Key Management Infrastructure/Public Key Infrastructure (KMI/PKI) and a discussion of detect-and-respond for providing warnings, detecting and characterizing suspected cyber attacks, coordinating effective responses, and performing investigative analyses of attacks.
- Incorporated old Appendix E into Chapter 8, Supporting Infrastructure.
- Created Appendix E, Office of the Secretary of Defense (OSD) Information Assurance (IA) Policy Robustness Levels.

### **Changes in IATF Release 2.0.1—22 September 1999**

Release 2.0.1 changes consisted mostly of formatting and graphical updates. These changes included—

- Redrawing the remaining graphics retained from Release 1.1 for greater clarity and consistency.
- Correcting some acronyms.
- Updating table formats and headings.
- Changing the page heading to “IATF Release 2.0.1—September 1999.”

### **Changes in IATF Release 2.0—31 August 1999**

- Changed name to Information Assurance Technical Framework (IATF).
- Aligned the security solution frameworks with the four focus areas of the Defense-in-Depth strategy: Defend the Network and Infrastructure (Chapter 5), Defend the Enclave

Boundary/External Connections (Chapter 6), Defend the Computing Environment (Chapter 7), and Supporting Infrastructures (Chapter 8).

- Made System High Interconnections and Virtual Private Networks (VPN) (NSF-R1.1 Section 5.2) and Availability of Backbone Networks (NSF R1.1 Section 5.7) elements of the new Chapter 5, Defend the Network and Infrastructure.
- Made Protection for Network Access (NSF R1.1 Section 5.3), Remote Access (NSF R1.1 Section 5.4), and Multilevel Security (NSF R1.1 Section 5.5) elements of the new Chapter 6, Defend the Enclave Boundary/External Connections.
- Made Security for System Applications (NSF R1.1 Section 5.6) an element of the new Chapter 7, Defend the Computing Environment.
- Changed name of NSF R1.1 Chapter 6 Security Management Infrastructure (SMI) to Key Management Infrastructure/Public Key Infrastructure (KMI/PKI) and made it an element of the new Chapter 8, Supporting Infrastructures.
- Added a new section, Wireless Security Solutions, to Chapter 5, Defend the Network and Infrastructure.
- Added a new Chapter 9, Information Assurance for the Tactical Environment.
- Added the outline of a new section, Detect and Respond, to Chapter 8.
- Added two new appendixes: Executive Summaries (Appendix F) and Protection Profiles (Appendix G).
- Revised Chapter 1 to include an explanation of the relationship of the GNIE IA effort, the Defense-in-Depth strategy, and the IATF.
- Updated the Remote Access section.
- Added “UNCLASSIFIED” to the header and footer of every page.
- Redrew some of the graphics retained from Release 1.1 for greater clarity and consistency.

## **Changes in NSF Release 1.1—3 December 1998**

- A (new or updated) Robustness section for Chapter 4.
- Complete revision of Sections 5.6, Security for System Applications, and 5.7, Availability of Backbone Networks.
- Inclusion of Appendix A, Abbreviations & Acronyms.
- A significantly expanded Chapter 4 focusing on security services, security robustness, and secure interoperability.

## UNCLASSIFIED

Summary of Changes  
IATF Release 3.1—September 2002

### **Changes in NSF Release 1.0—22 May 1998**

- Added a new Chapter 3 focused on security methodology.
- Added a new Chapter 4 focused on security services, security robustness, and secure interoperability.
- Added two new sections within Chapter 5 focused on security for system applications and backbone availability.
- Added a new Chapter 6 focused on security management infrastructure.
- Added appendices providing a glossary and amplifying information on some of the security solutions framework.
  - Glossary (Appendix B).
  - Characterization of Customer Community (Appendix C).
  - System Security Administration (Appendix D).
  - Public Key Infrastructure (PKI) Formats (Appendix E).

### **The Initial Network Security Framework (NSF) Document**

The first releases of the NSF (Releases 0.1 and 0.2) provided initial insight and guidance on a few categories of network security challenges. The third release (Release 1.0) provided an initial treatment of all of the primary topics that were suggested in the original outline and in the comments received.

# Chapter 1

## Introduction

---

The Information Assurance Technical Framework (IATF) exists to address questions such as:

- How do I go about defining information protection needs and solutions?
- What technology exists to give the protection I need?
- What organizational resources are available to help locate the protection I need?
- What kind of markets exist for Information Assurance (IA) products and services?
- Where should research in IA approaches and technology be focused?
- What are the principles of IA?

This evolving document is published to provide recommendations and information on current information assurance concerns and practices to System Security Engineers and others who address IA in their work. Over time it will reflect changes in policy, technology, environments, and the uses made of systems that depend upon information.

### 1.1 Objectives

The Framework has several objectives:

- Raise the awareness among users of information-dependent systems of information assurance technologies.
- Identify technical solutions to IA needs in accordance with national policies.
- Employ the technology focus areas of a *Defense-in-Depth* strategy to define approaches to IA.
- Define the security functions and protection levels needed for different situations or mission scenarios (referred to as “cases”).
- Present the IA needs of users of information-based systems.
- Highlight the need to engage a team of IA or information systems security experts to resolve pressing security needs.
- Aid the development of IA solutions that satisfy IA needs by highlighting gaps in the currently available commercial and government protection technologies.
- Provide guidance for solving IA issues by offering tutorials on available technologies, trade-offs among available solutions (at a technology versus product level), and descriptions of desirable solutions’ characteristics.
- Assist purchasers of IA products by identifying important security-related features that should be sought.

## 1.2 Intended Audiences

The Framework addresses the needs of several groups of people. The following describes each group and indicates how the document can be used.

- **System security engineers.** To assist in developing IA solutions tailored to a particular customer's needs. The customer's needs can be compared with the various Framework technology areas, cases, and recommended solutions. From these, a tailored solution can be created for this particular customer.
- **Customers.** To provide answers to the myriad issues and technical challenges involved in selecting adequate IA features and assurance levels for their system and networks. Customers can include system users, managers, and security officers or administrators. With this knowledge, customers can successfully interact with security engineers and architects to design a comprehensive IA solution.
- **Scientists and researchers.** To focus their efforts on customer requirements not being met by current technology. Thus, the Framework will highlight future IA technology and identify technology gaps for use by both government and commercial research communities.
- **Commercial product and service providers.** To gain insight into the needs of customers. Industry will get an indication of the current and future markets for IA products and services.
- **Standards bodies and consortia.** To provide guidance in developing standards for commercial products. A major emphasis within the customer base focuses on the use of commercial products, which are driven by commercial standards. The IATF highlights gaps in the available standards that will help focus efforts to influence the standards bodies.

## 1.3 Context

### 1.3.1 Information Infrastructures Defined

The IATF is based on the concept of an information infrastructure. An information infrastructure comprises communications networks, computers, databases, management, applications, and consumer electronics and can exist at the global, national, or local level. The global information infrastructure is not controlled or owned by a single organization—“ownership” is distributed among corporate, academic, and government entities as well as by individuals. The Internet is an example of a global information infrastructure as is the global telecommunications network. Most organizations that communicate externally rely upon this global system in conducting their operations using a combination of global, virtual networks, dedicated networks, Wide Area Networks (WAN), and customized information systems.

A national information infrastructure is the collection of information infrastructures used by the nation to conduct its business, whether government or commercial. One instance of a national infrastructure is the United States (U.S.) critical infrastructure as defined in Presidential Decision Directive (PDD) 63. Before the growth of multinational companies and the advent of the Internet, one could easily identify a national information infrastructure. In the last few decades however, the lines between the global and national information infrastructures have blurred significantly. Each country will need to decide whether the distinction between the two has merit; if so, criteria will be required to categorize an asset as qualifying as part of a “national” information infrastructure. In the U.S., one possible criterion might be whether assets are subject to U.S. laws, regulations, and policies.

Local information infrastructures are the dedicated assets an organization operates in conducting its business; they consist mainly of commercial information systems, network technologies, and applications. Security measures are applied by the owner or operator of the local information infrastructure—defined either as an organization, or even a business unit within an organization.

## **1.3.2 Categorizing Information and Information Infrastructures**

Within the organization, information processed using these assets are generally grouped into functional categories such as administrative, personnel, or logistics. Some information may be available to the public, some considered private. There are many types of private information; companies have different types of proprietary information, government organizations have many types of classified information, including law enforcement, secret, top secret, and sensitive compartmented information. These divisions of information availability are also called information domains.

To accomplish their various missions and to protect their critical functions, all organizations—both government and private sector—have public and private information they need to safeguard. The mission or business environment determines how, and to what extent, specific information is protected. What is publicly releasable to one organization may be private to another, and vice versa. The Federal Government uses specific categories for some of its private information under the heading of “classified information.” In general, the government recognizes four classification levels: unclassified, confidential, secret, and top secret. Within the classification levels, there may be subcategories specific to individual communities. Three of the classification categories—confidential, secret, and top secret—address private information. The fourth level of classification covers both private information (such as sensitive or Privacy Act Information) and public information.

Several types of information could be considered private. One example would be law enforcement information that could potentially damage or impair law enforcement efforts if improperly protected or handled. Proprietary information is much the same for the business community; the information would be harmful to the business if it were released. Information covered under the Privacy Act including personal financial, medical, and other such information



is also considered sensitive. The government handles a variety of classified and sensitive information supporting research, engineering, logistic, administrative, and acquisition functions across the different organizations and agencies.

Most organizations assign more rigorous requirements to protecting their private information than their public information. First access is controlled. For example, within an organization, a human resources or finance person may have complete access to personnel and payroll databases and servers, but may not have access to the most sensitive research and development information. Within the government-classified realm this is accomplished by assigning different classification levels, special compartments, and need-to-know designations. This is illustrated in Figure 1-1.

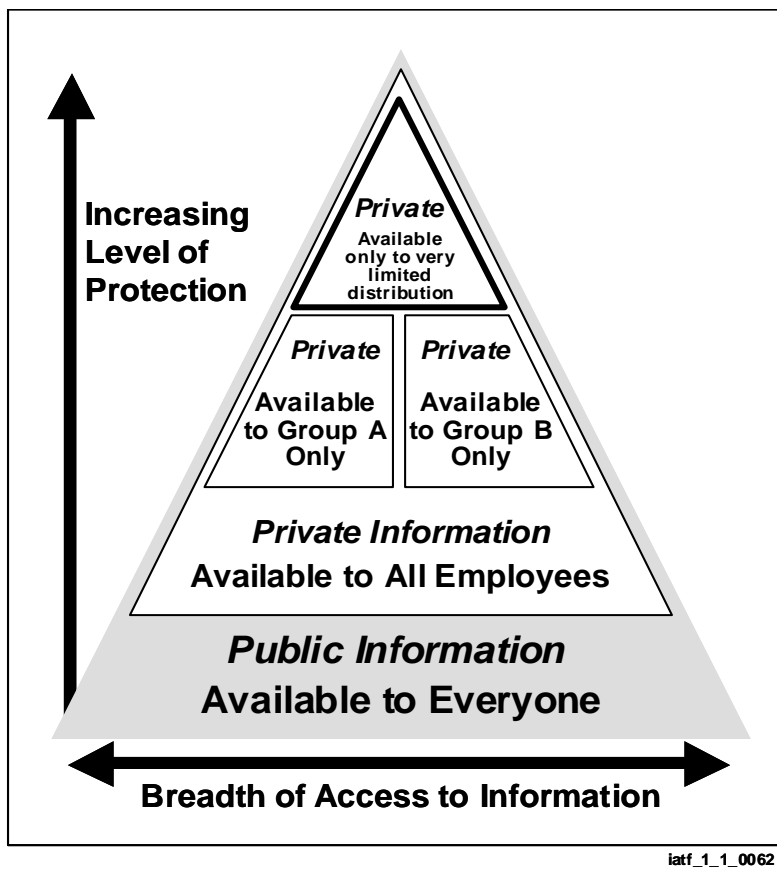

**Figure 1-1. Availability and Protection to Information**

In addition to access controls, more robust technical security measures are implemented. Organizations acknowledge that the potential loss from exposing private information to the public would be high and therefore the additional cost of protection is warranted. In Figure 1-1, the most stringent security measures would be applied to the information and information infrastructures associated with the top triangle.

The partitioning of information according to access control, need, and levels of protection required yields categories of information. The categories are often called *information domains*. Organizations implement specific mechanisms to enforce the information partitioning and to provide for the deliberate flow of information between information domains.

Protecting information in a collaborative environment presents its own challenges. Organizations sharing information need to agree upon the sensitivity level of the information as well as methods to protect it. Often one organization regards information as more or less sensitive than its partner and officials from both organizations must negotiate a mutually agreeable solution. This occurs between companies sharing proprietary information, between government organizations involved in a joint project, and very often, between countries.

### 1.3.3 Boundaries and Information Infrastructures

When considering security for information infrastructures, it is important to understand the concept of boundaries. Information assets exist in physical *and* logical locations, and boundaries exist between these locations. An understanding of what is to be protected from external influences can help ensure that adequate protection measures are applied where they will be most effective. However, when analyzing a real-world example, this boundary is not so easily identified. Sometimes the boundary is defined as physical—people, information, and information systems associated with one physical location. But this ignores the reality that, within a single location, many different security policies may be in place, some covering public information and some covering private information.

Other times it is defined as surrounding the information and information systems that are governed by a policy within a single location. This definition, however, does not address the fact that policies cross physical boundaries. Further complicating the matter is that, many times, a single machine or server may house public *and* private information. So, multiple boundaries may exist within a single machine. Figure 1-2 illustrates these complexities associated with defining boundaries. It shows one organization with facilities in two locations, each processing multiple levels of information. In addition, the private network is also connected to the Internet.

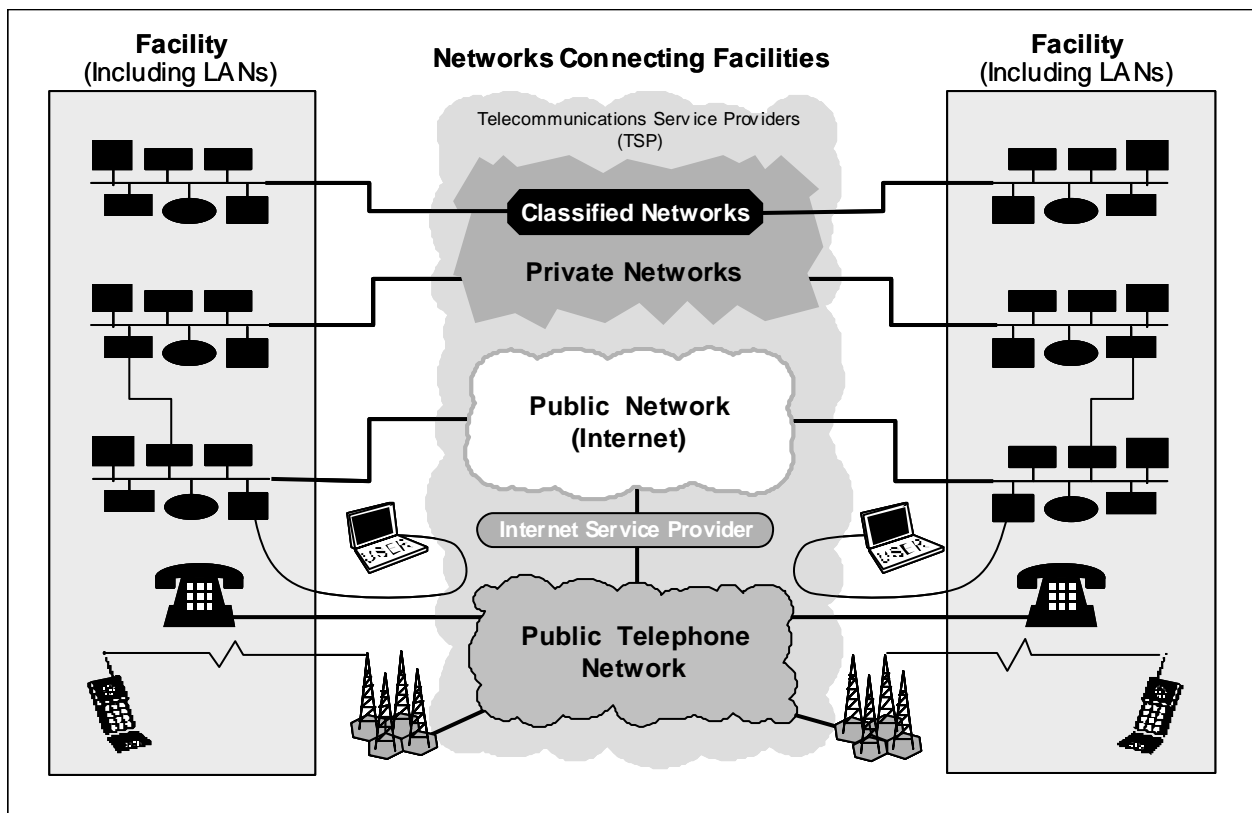

iatf\_1\_2\_0063

Figure 1-2. Information Infrastructure Elements

In this case, the physical location might be considered a boundary, as might the logical boundaries associated with the different levels of information.

### 1.3.4 Information Assurance Framework Areas

Given the complexity of information systems, discussion of *how to protect* them is challenging unless a common framework is employed. The IATF document employs a framework that partitions the IA technology aspects of information systems into the following four areas, as shown in Figure 1-3.

1. Local Computing Environments.
2. Enclave Boundaries (around the local computing environments).
3. Networks and Infrastructures.
4. Supporting Infrastructures.

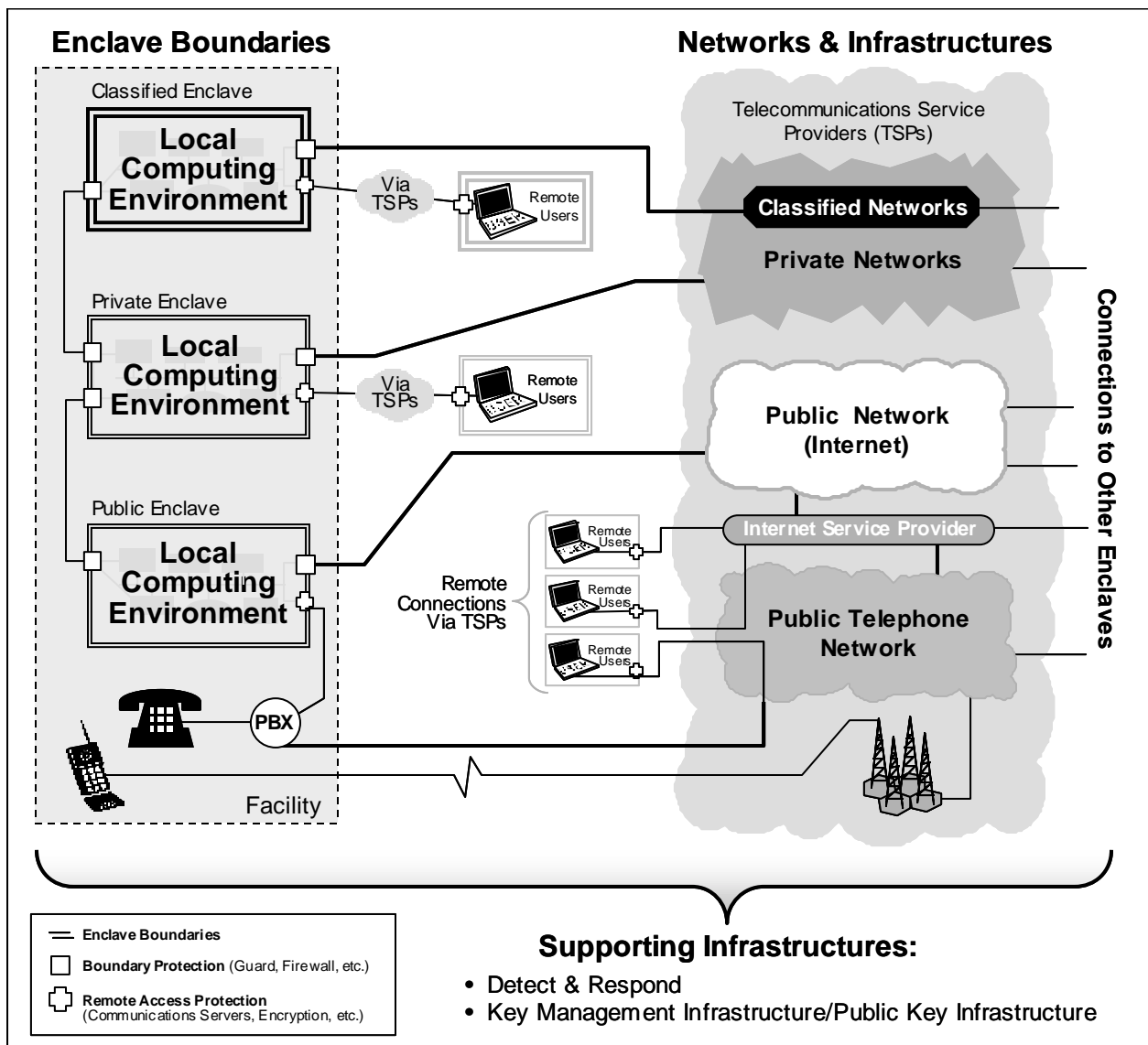

iatf\_1\_3\_0064

Figure 1-3. IA Technology Framework Access

By partitioning the discussion into these four areas, aspects of IA technology for the information system can be focused upon and more clearly presented. However, these areas are overlapping bins of concern. Effective implementation of IA for a given information system involves the interplay of actions taken throughout the information system—across all four technology framework areas. In the paragraphs that follow, the four framework areas are described further.

## Local Computing Environments Framework Area

The local user *computing environment* typically contains servers, clients, and the applications installed on them. Applications include, but are not limited to, those that provide services such as scheduling or time management, printing, word processing, or directories. This environment is represented in Figure 1-4.

Looking across the range of computing environments, there are several broad categories of information systems that organizations employ. In both the private sector and the government, one will find large legacy information systems that have been developed over many years and at considerable expense to satisfy unique mission/business needs. These will likely remain in place for some time to come. A large number of organizations have also heavily invested in the use of commercial off-the-shelf (COTS) products or customized versions of COTS information system components and products tailored for their specific use. Organizations using customized products will probably transition to full COTS implementations as the product offerings address their needs more directly.

Most organizations want to use multiple applications to perform their operational mission functions. As a result, users are struggling to integrate the ever-growing range of applications into an effective information processing capability. Each of these applications will place unique requirements on the supporting infrastructure.

Across the range of computing environments, the customer base needs IA solutions in many existing application areas. Security of the computing environment focuses on servers and clients to include the applications installed on them, the operating systems, and host-based monitoring capabilities. Application areas requiring IA solutions include the following:

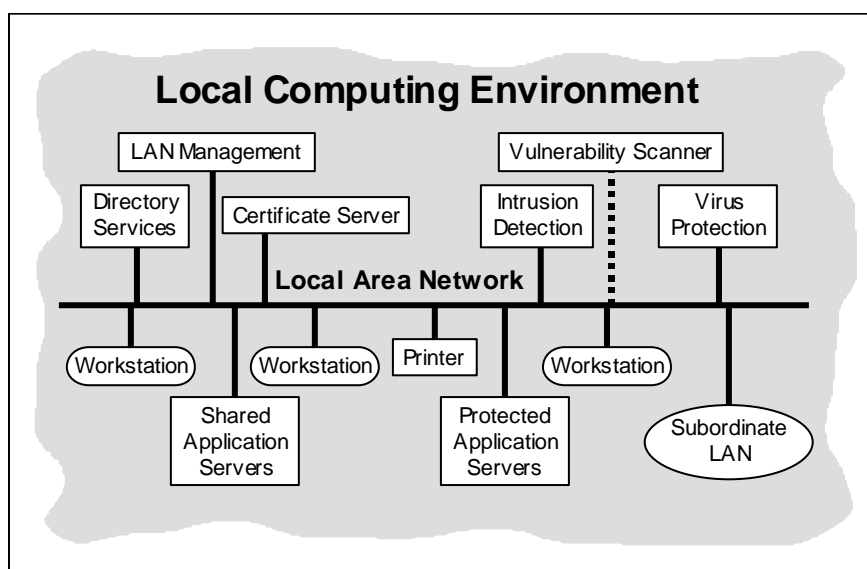

iatf\_1\_4\_0065

**Figure 1-4. Local Computing Environment Area**

- Messaging, e.g., electronic mail (e-mail).
- Operating systems.
- Web browser.
- Electronic commerce.
- Wireless access.
- Collaborative computing.
- Database access.

## Enclave Boundaries Framework Area

A collection of local computing devices interconnected via Local Area Networks (LAN), governed by a single security policy, regardless of physical location is considered an “enclave.” As discussed above, because security policies are unique to the type, or level, of information being processed, a single physical facility may have more than one enclave present. Local and remote elements that access resources within an enclave must satisfy the policy of that enclave. A single enclave may span a number of geographically separate locations with connectivity via commercially purchased point-to-point communications (e.g., T-1, T-3, Integrated Services Digital Network [ISDN]) along with WAN connectivity such as the Internet. These concepts are represented in Figure 1-5.

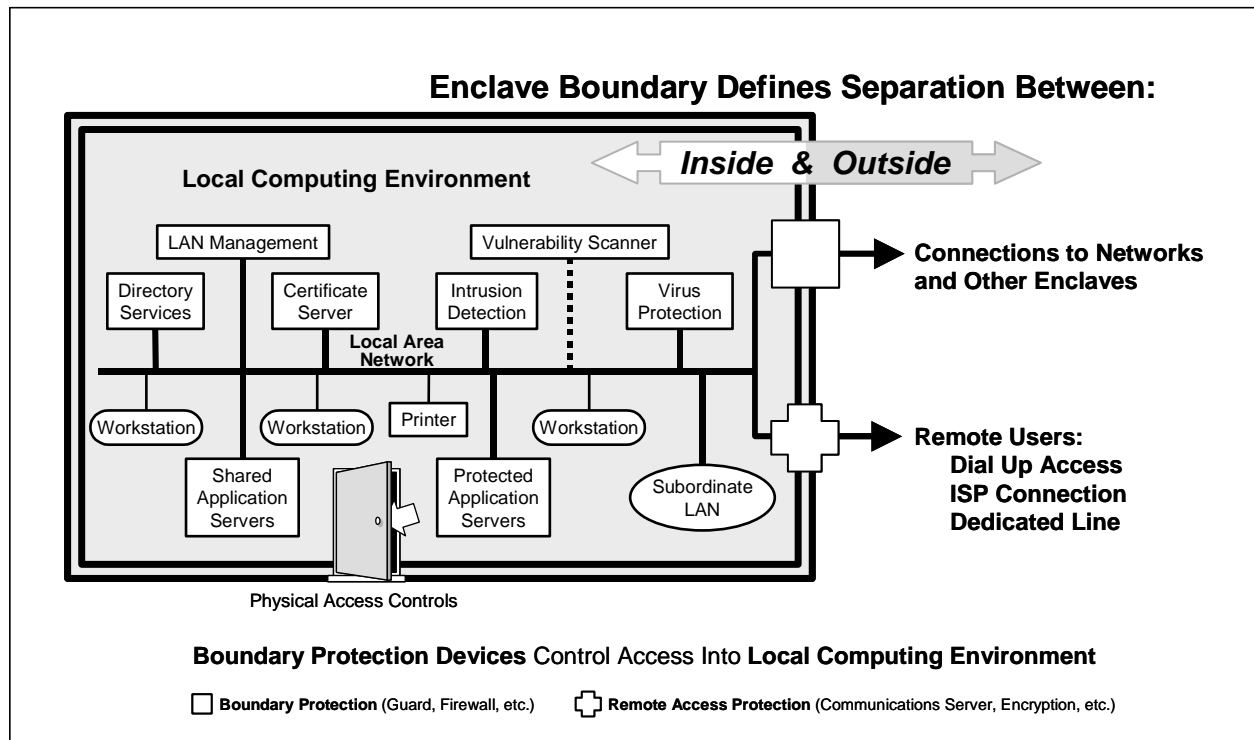

iatf\_1\_5\_0066

Figure 1-5. Enclave Boundaries Framework Area

The enclave boundary is the point at which information enters or leaves the enclave or organization. Many organizations have extensive connections to networks outside their control. Therefore, a layer of protection is needed to ensure that the information entering does not affect the organization's operation or resources, and that the information leaving is authorized.

Many organizations employ multiple types of external network connections through the enclave boundary. These include:

- Connections to external networks (such as the Internet) to exchange information with another enclave or to access data on a network.
- Three types of connections to remote users—dial-up access via the public telephone network, connection to an Internet Service Provider (ISP) by direct connection (cable modem), or by dial-up access, and dedicated line connectivity through a Telecommunications Service Provider (TSP) (see also Figure 1-3).
- Connections to other local networks operating at different classification levels.

Each connection requires different types of solutions to satisfy both operational and IA concerns. Internets invite access through the boundary, with security only as good as the entire network through which the data is being transported.

## Networks and Infrastructures

The network and infrastructure of these networks provide connectivity between enclaves; they contain Operational Area Networks (OAN), Metropolitan Area Networks (MAN), Campus Area Networks (CAN), and LANs, extending coverage from broad communities to local bases. The transport networks contain the information transmission components (e.g., satellites, microwave, other Radio Frequency (RF) spectrum, and fiber) to move information between the network nodes (e.g., routers and switches). As depicted in Figure 1-6, other important components of the network infrastructure are network management, domain name servers, and directory services.

The typical types of transport networks and services used by the government and industry now, and that will be used in the future, can be logically grouped into three areas:

1. Public/commercial networks and network technologies.
2. Dedicated network services.
3. Government-owned and operated.

The public/commercial networks used by the private sector and government include the Internet, the Public Switched Telephone Network (PSTN), and wireless networks. Wireless networks include cellular, satellite, wireless LAN, and paging networks. Access to networks is typically gained through telecommunications service providers. These public networks are wholly owned and operated by these private sector providers.

To obtain dedicated network services, the government has structured a number of network service contracts that procure network services. These include the Federal Wireless Service and

FTS 2000. Public network providers provide access to networks through an arrangement with the government. Private sector organizations obtain telecommunications services in a similar manner, leasing and purchasing dedicated commercial telecommunications services.

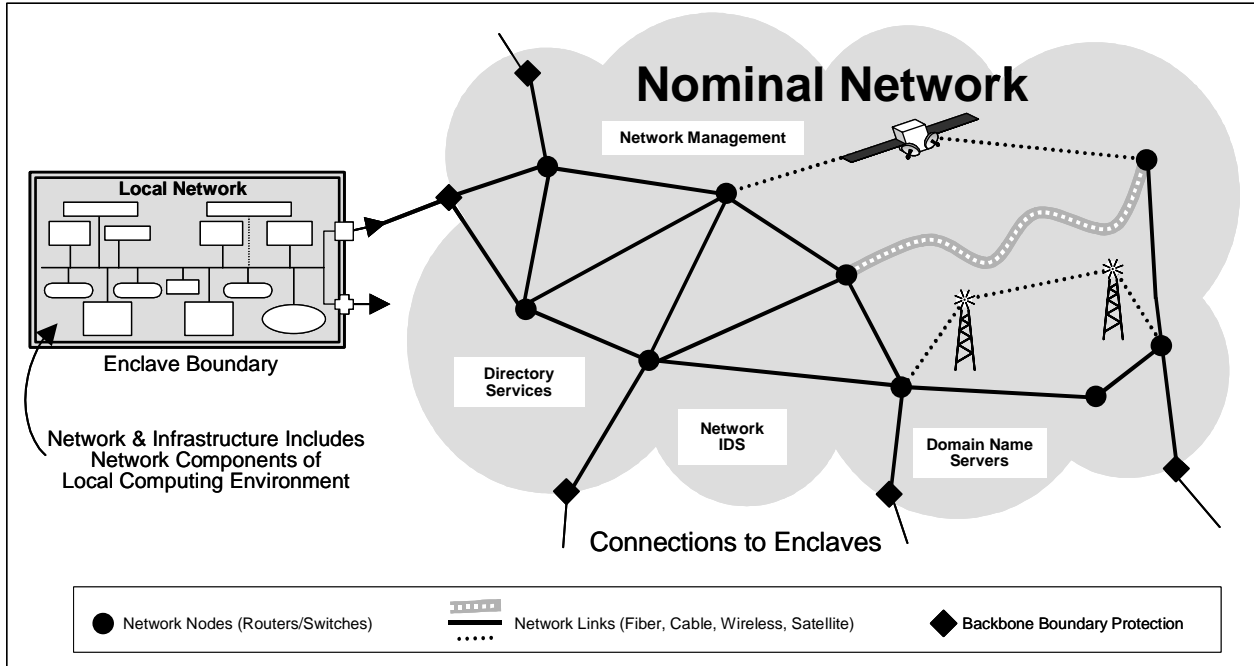

iatf\_1\_6\_0067

**Figure 1-6. Network and Infrastructure Framework Structure**

Several government organizations own and operate networks. For example, the Department of Energy’s Energy Science Network (ESNet), the Federal Aviation Administration’s Agency Data Telecommunications Network (ADTN), and the DoD Secret Internet Protocol Router Network (SIPRNET). These networks may begin as private networks, go through leased or public networks, and terminate as private networks. They also include totally owned and operated networks such as MILSTAR. Appendix C provides additional information on this category of networks.

## Supporting Infrastructures

Also present in the information technology environment are *supporting infrastructures* that provide the foundation upon which IA mechanisms are used in the network, enclave, and computing environments for securely managing the system and providing security-enabled services. Supporting infrastructures provide security services for networks, end-user workstations, servers for Web, applications, and files, and single-use infrastructure machines (e.g., higher-level Domain Name Server [DNS] services, higher-level directory servers). The two areas addressed in the IATF are key management infrastructure (KMI), which includes Public Key Infrastructures (PKI), and detect and respond infrastructures.

## Key Management Infrastructure

A KMI provides a common unified process for the secure creation, distribution, and management of the public key certificates and traditional symmetric keys that enable security services for the network, enclave, and computing environment. These services enable the identities of senders and receivers to be reliably verified, and the information to be protected from unauthorized disclosure and modification. The KMI must support controlled interoperability for users, consistent with established security policies for each user's community.

## Detect and Respond

The detect and respond infrastructure enables rapid detection of, and reaction to, intrusions. It also provides a "fusion" capability so one incident can be viewed in relation to others. This allows analysts to identify potential activity patterns or new developments. In most organizations that implement a detect and respond capability, local centers monitor local operations and feed a larger regional or national center. The infrastructure required includes technical solutions such as intrusion detection, and monitoring software; and a cadre of skilled specialists, often referred to as a Computer Emergency Response Team (CERT).

### 1.3.5 Nature of Cyber Threats

Information systems and networks offer attractive targets. They should be resistant to attack from the full range of threat-agents—from hackers to nation states—and they must limit damage and recover rapidly when attacks do occur.

The IATF considers five classes of attacks:

1. Passive.
2. Active.
3. Close-In.
4. Insider.
5. Distribution.



# UNCLASSIFIED

Introduction  
IATF Release 3.1—September 2002

The key aspects of each class of attack are summarized in Table 1.1.

**Table 1-1. Classes of Attack**

<b>Attack</b>	<b>Description</b>
<b>Passive</b>	Passive attacks include traffic analysis, monitoring of unprotected communications, decrypting weakly encrypted traffic, and capturing authentication information (e.g., passwords). Passive intercept of network operations can give adversaries indications and warnings of impending actions. Passive attacks can result in the disclosure of information or data files to an attacker without the consent or knowledge of the user. Examples include the disclosure of personal information such as credit card numbers and medical files.
<b>Active</b>	Active attacks include attempts to circumvent or break protection features, introduce malicious code, or steal or modify information. These include attacks mounted against a network backbone, exploitation of information in transit, electronic penetrations into an enclave, or attacks on an authorized remote user when attempting to connect to an enclave. Active attacks can result in the disclosure or dissemination of data files, denial of service, or modification of data.
<b>Close-in</b>	Close-in attack is where an unauthorized individual is in physical close proximity to networks, systems, or facilities for the purpose of modifying, gathering, or denying access to information. Close proximity is achieved through surreptitious entry, open access, or both.
<b>Insider</b>	Insider attacks can be malicious or non-malicious. Malicious insiders have the intent to eavesdrop, steal or damage information, use information in a fraudulent manner, or deny access to other authorized users. Non-malicious attacks typically result from carelessness, lack of knowledge, or intentionally circumventing security for non-malicious reasons such as to “get the job done.”
<b>Distribution</b>	Distribution attacks focus on the malicious modification of hardware or software at the factory or during distribution. These attacks can introduce malicious code into a product such as a back door to gain unauthorized access to information or a system function at a later date.

The relationship of these attack classes to the technology framework areas is shown in Figure 1-7. Subsequent sections of the IATF will provide an overview of the IA strategy for countering or mitigating the effects of these attacks.

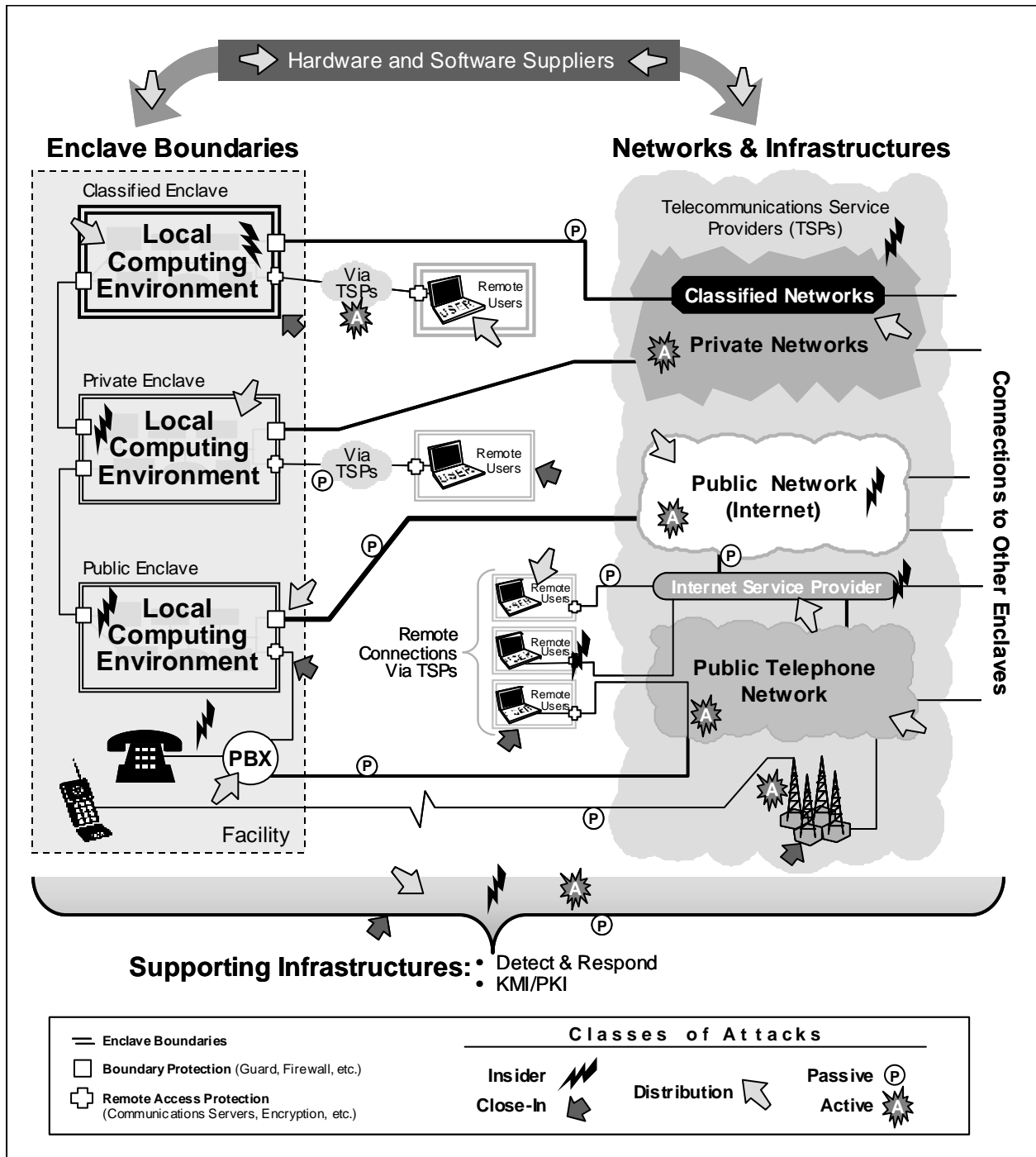

iattf\_1\_7\_0068

Figure 1-7. Classes of Attacks on the Information Infrastructure

## 1.4 Defense-in-Depth

The Department of Defense (DoD) has led the way in defining a strategy called *Defense-in-Depth*, to achieve an effective IA posture. The underlying principles of this strategy are applicable to any information system or network, regardless of organization. Essentially, organizations address IA needs with *people* executing *operations* supported by *technology*.

Figure 1-8 illustrates the principal aspects of the Defense-in-Depth strategy—personnel, technology, and operations, outlined as follows.

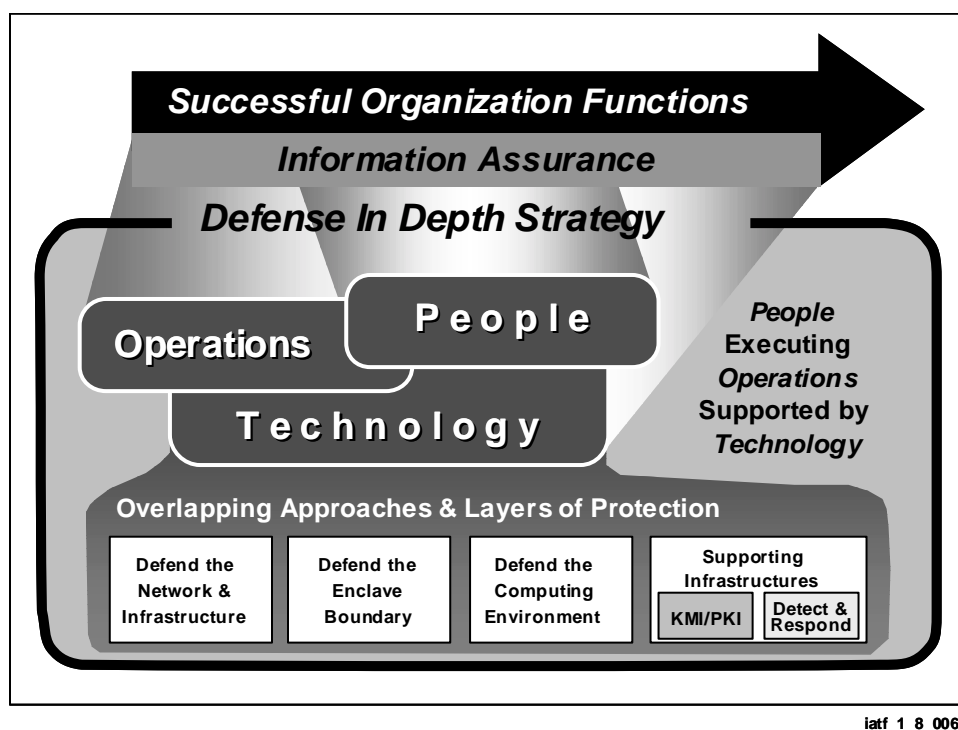

**Figure 1-8. Principal Aspects of the Defense-in-Depth**

- People
  - Policies and Procedures
  - Training and Awareness
  - Physical security
  - Personnel security
  - System security administration
  - Facilities Countermeasures
- Technology
  - IA Architecture framework areas
  - IA criteria (security, interoperability, and PKI)
  - Acquisition integration of evaluated products
  - System risk assessments
- Operations
  - Security policy
  - Certification and accreditation
  - Readiness assessments
  - Security management
  - Key management
  - Attack sensing and warning response
  - Recovery and reconstitution

Of the three principal aspects of this strategy, the IATF focuses on technology and on providing a framework for providing overlapping layers of protection against cyber threats. By this approach, a successful attack against one layer or type of protection does not result in the compromise of the entire information infrastructure.

Other policies, procedures, and frameworks are focused on addressing the people and operations aspects of a Defense-in-Depth strategy.

## **1.4.1 Defense-in-Depth and the IATF**

Information infrastructures are complicated systems with multiple points of vulnerability. To address this, the IATF has adopted the use of multiple IA technology solutions within the fundamental principle of the Defense-in-Depth strategy, that is, using layers of IA technology solutions to establish an adequate IA posture. Thus, if one protection mechanism is successfully penetrated, others behind it offer additional protection. Adopting a strategy of layered protections does not imply that IA mechanisms are needed at every possible point in the network architecture. By implementing appropriate levels of protection in key areas, an effective set of safeguards can be tailored according to each organization's unique needs. Further, a layered strategy permits application of lower-assurance solutions when appropriate, which may be lower in cost. This approach permits the judicious application of higher-assurance solutions at critical areas, (e.g., network boundaries).

The Defense-in-Depth strategy organizes these requirements into four principle areas of focus:

1. Defend the Network and Infrastructure.
2. Defend the Enclave Boundary.
3. Defend the Computing Environment.
4. Supporting Infrastructures.

These four areas of focus for the Defense-in-Depth strategy parallel the four framework areas discussed in Section 1.3.4.

## **1.5 IATF Organization**

This framework document has been assembled to present the technology aspects associated with the Defense-in-Depth framework areas; each of the four areas is presented in a separate chapter. Also present are chapters that address concerns that cut across the technology areas or address the IA needs of particular environments or technologies.

To focus on the needs of a diverse group of readers, the IATF is organized into four primary parts shown in Figure 1-9:

- Main Body (Chapters 1-4),
- Technical Sections (Chapter 5-10 and Appendices A-E, H-J),
- Executive Summaries (Appendix F),
- Protection Profiles (Appendix G).

The main body of the IATF (Chapters 1 through 4) provides the general IA guidance that information system users, security engineers, security architects, and others can use to gain a better understanding of the IA issues involved in protecting today's highly interconnected information systems and network backbones. The technical sections (Chapters 5 through 10 and Appendices A through E and H through J) provide specific requirements and solutions for each of the Defense-in-Depth areas. The technical sections also offer the government and private research communities a perspective on technology gaps that exist between today's best available protection solutions and the desired IA capabilities.

For users and security engineers looking for more definitive guidance, the Executive Summaries portion of the IATF provides outlines of the threats, requirements, and recommended solutions for a variety of specific protection needs in specific environments. The goal of this collection of Executive Summaries is to offer quick reference guides (each summary is targeted to be fewer than three pages in length) that users and security engineers can peruse to find scenarios similar or identical to their own IA challenges.

Executive Summaries are under development and will be included in a future release of the IATF. For this version of the IATF, an outline illustrating the content of an Executive Summary is provided in Appendix F. In identifying IA solutions, the Executive Summaries will point to the documentation sources (e.g., specifications and protection profiles) containing the set of testable requirements satisfying the user need.

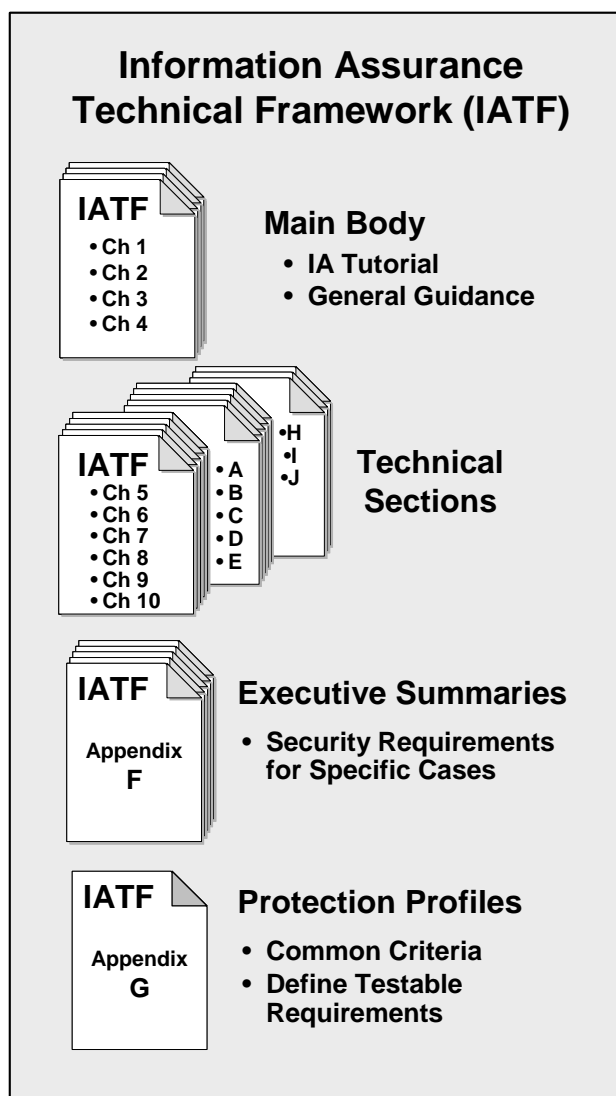

iatf\_1\_9\_0070

**Figure 1-9. Composition of the IATF**

The fourth part of the IATF includes referenced Protection Profiles. Protection Profiles (Appendix G) capture the assurance requirements and functionality for a system or product. They employ the international standard Common Criteria language and structure.

**UNCLASSIFIED**

Introduction  
IATF Release 3.1—September 2002

**This page intentionally left blank.**

## Chapter 2

# Defense in Depth

---

## 2.1 Introduction and Context Diagrams

Defense in Depth is a practical strategy for achieving information assurance (IA) in today's highly networked environments. It is a practical strategy because it relies on the intelligent application of techniques and technologies that exist today. This strategy recommends a balance among protection capability, cost, performance, and operational considerations. This chapter presents an overview of the major elements of this strategy and provides links to resources that offer additional insight.

### 2.1.1 Examples of User Environments

The following subsections introduce examples of customer computing environments and depict how they can interconnect with other organizational enclaves. The Information Assurance Technology Framework (IATF) technologies and suggested solutions provided apply to the computing environments described in these subsections. The Defense in Depth strategy and objectives described below apply equally to the federal computing environment and the Department of Defense (DoD) and concepts concerning computing environments. Defense of the computing environment, the enclave, and the network and infrastructure, apply in each environment in which all systems are interconnected.

#### 2.1.1.1 Federal Computing Environment

The interconnection of Department of Energy (DOE) research facilities, weapons laboratories, regional operations offices, and academic facilities is one example of a federal computing environment. The DOE information infrastructure is interconnected via several DOE wide area networks (WAN), one of which is the Energy Science Network (ESNet).

ESNet is a high-performance data communications backbone that provides DOE with widespread support for research and mission-critical applications. It supports both classified and unclassified DOE mission-oriented networking for scientists, engineers, and their administrative support. The ESNet consists of an asynchronous transfer mode (ATM) backbone and multiple local area networks (LAN) interconnected to establish a global network capability. ESNet permits virtual network architectures so that virtual networks can be layered on top of the existing network while running totally independent on the host network (i.e., ESNet). One DOE virtual network hosted on ESNet is SecureNet, a classified DOE support network. The virtual private network (VPN), SecureNet, provides a connection between three application-specific integrated circuits (ASIC) teraflop supercomputers, DOE headquarters, and other defense



program facilities across the United States. As a result, scientists and researchers at any of these DOE sites have on-demand access to the supercomputers.

Figure 2-1 presents a conceptual diagram of a typical DOE site within the broader DOE computing environment. The typical DOE site has two primary networks (or three, if the site processes classified information).

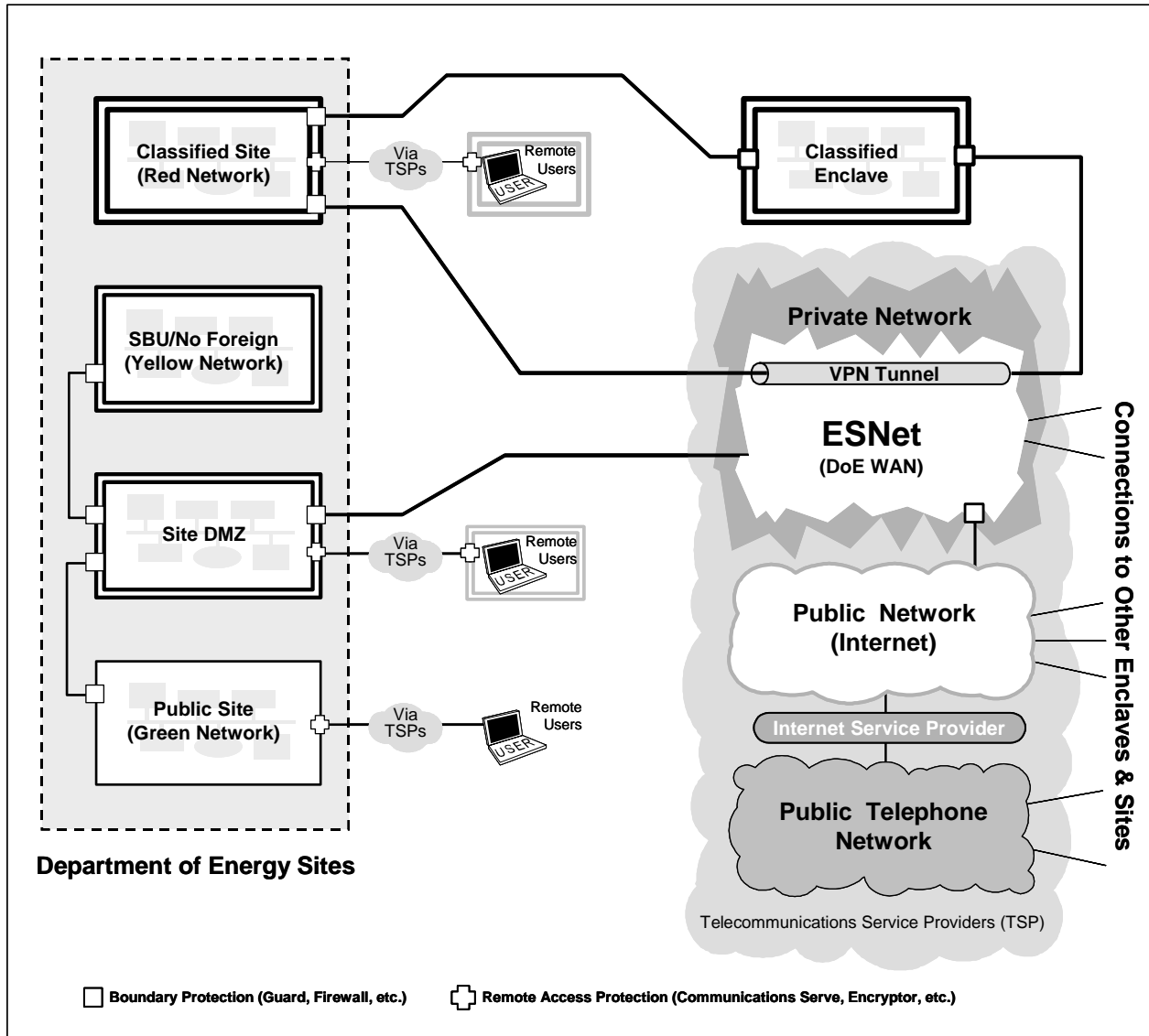

Figure 2-1. Federal Computing Environment—DOE

The primary networks include a “Green” unclassified or public network; a “Yellow” sensitive but unclassified/no-foreign (Unclassified but Controlled/NOFORN) network; and a “Red,” or classified, network. The Green, Yellow, and Red networks may each consist of one LAN or of multiple subnetworks. The typical DOE site has implemented a demilitarized zone (DMZ) or information protection network (IPN) that acts as the single point of entry into the site and

defends the enclave boundary or external connection(s). Within the Yellow and Red LANs, virtual networks are established to support various mission functions within the site. Physical isolation is primarily used to maintain the confidentiality and integrity of classified data. Carefully controlled connectivity is provided between the Red network, the Yellow network, and ESNet when data transfer outside the enclave is required.

All public information, Web-serve, and nonsensitive information are located on the Green network, which is normally protected by the site's DMZ resources. Remote access to the site will be established via the DMZ. A typical DOE site obtains Internet access via the ESNet connection.

### **2.1.1.2 DoD Computing Environment**

The Defense Information Infrastructure (DII) environment is an example of one of the U.S. Government's largest and most complex information infrastructures. The DII supports more than 2 million primary users (with extensions to an additional 2 million users). Included within the DII are some 200 command centers and 16 large data centers, the Defense Megadata Centers. The basic user environments are enclaves (physically protected facilities and compounds), incorporating more than 20,000 local networks and some 4,000 connections to a backbone network. The DII also supports more than 300,000 secure telephone users.

The DII implements a number of global virtual networks that support a range of mission functions, for example, logistics, intelligence, and using WANs such as the Joint Worldwide Intelligence Communications System (JWICS) and the Secret Internet Protocol Router Network (SIPRNet) for global connectivity. In the past, this information infrastructure was based on dedicated networks and customized information systems; today, DoD is almost totally dependent on commercial services within the Nationwide Information Infrastructure (NII) and the broader global information infrastructure.

Figure 2-2 presents a system context diagram of a typical user site or facility within the broader DII structure. The typical user facility has several LANs that support the mission functional areas. Today, physical isolation is primarily used to maintain the confidentiality and the integrity of different classification levels of traffic. Within these isolated LANs, virtual networks are established to support the various mission functions within the enclave. Carefully controlled connectivity is provided between networks of different classification levels when boundaries are required.

For example, DoD organizations have robust, worldwide intelligence systems operating at top secret-sensitive compartmented information (TS-SCI) that carry significant levels of unclassified traffic. This supports the organizations' need to communicate with others within the intelligence community. Within the same TS-SCI enclaves, customers have secret and unclassified systems with less-than-robust connectivity to non-intelligence-community users. To reach a mixed community of users, unclassified information may have to flow over separate unclassified, secret, and TS-SCI systems. Moving information between these systems (enclaves) is complicated because of the need to comply with policy regarding releasability.

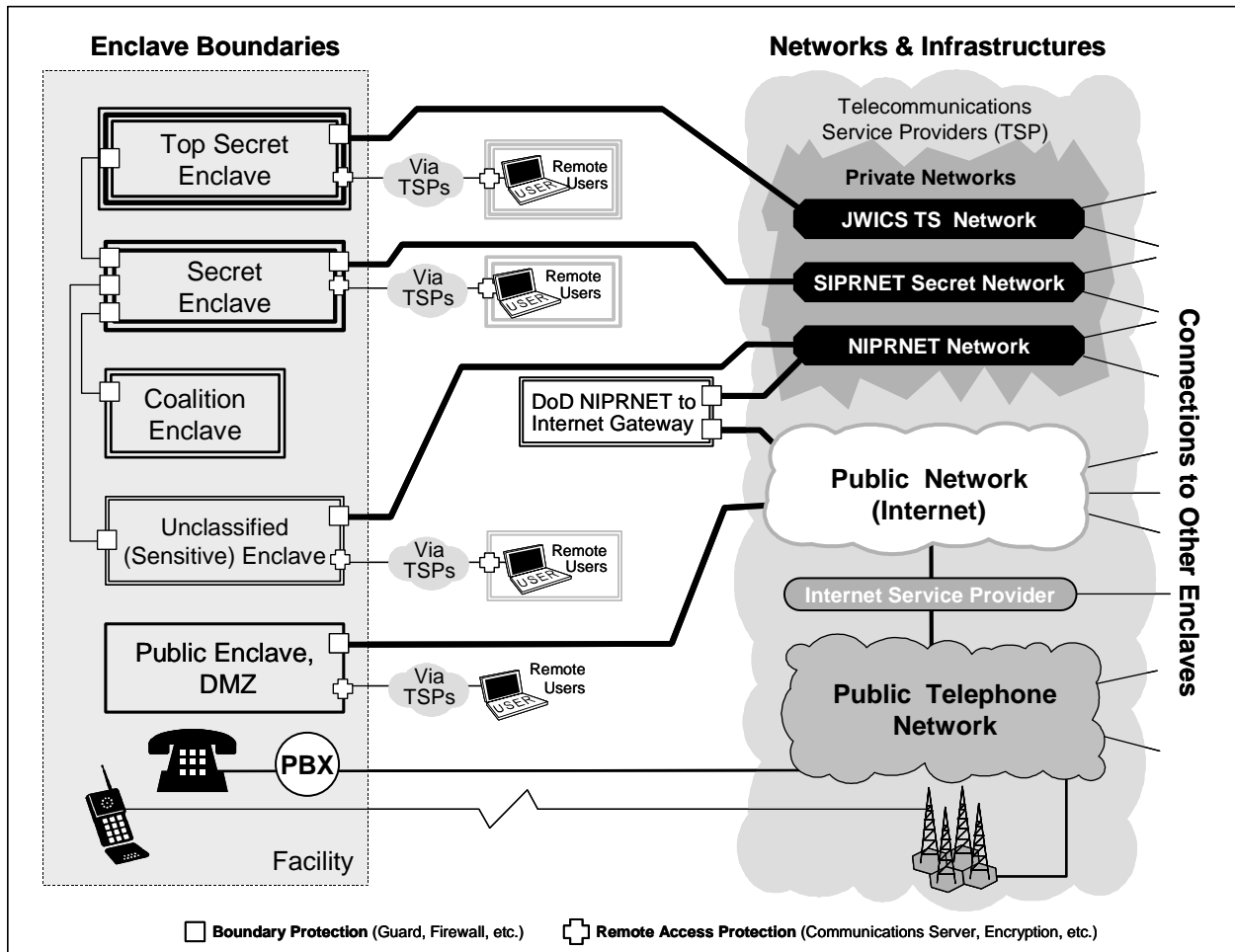

iatf\_2\_2\_2\_0131

Figure 2-2. Federal Computing Environment—DoD

## 2.2 Adversaries, Motivations, and Classes of Attack

To effectively resist attacks on its information and information systems, an organization must characterize its adversaries, their potential motivations, and their attack capabilities. Potential adversaries might include nation states, terrorists, criminal elements, hackers, or corporate competitors. Their motivations might include intelligence gathering, theft of intellectual property, causing embarrassment, or just anticipated pride in having exploited a notable target. The methods of attack might include passive monitoring of communications, active network attacks, close-in attacks, exploitation of insiders, and attacks through the industry providers of the organization’s information technology (IT) resources.

In addition to guarding against intentional attack, the organization must protect against the detrimental effects of nonmalicious events such as fire, flood, power outages, and user error.

**For clarity and understanding, the rest of Section 2.2 is a reprint of Section 1.3 of the IATF.**

Information systems and networks offer attractive targets. Therefore, they should be resistant to attack from the full range of threat agents—from hackers to nation states—and must be able to limit damage and recover rapidly when attacks do occur.

The IATF considers five classes of attacks:

- Passive.
- Active.
- Close-In.
- Insider.
- Distribution.

The key aspects of each class of attack are summarized in Table 2-1.

**Table 2-1. Classes of Attack**

Attack	Description
<b>Passive</b>	Passive attacks include traffic analysis, monitoring of unprotected communications, decrypting weakly encrypted traffic, and capture of authentication information (e.g., passwords). Passive intercept of network operations can give adversaries indications and warnings of impending actions. Passive attacks can result in disclosure of information or data files to an attacker without the consent or knowledge of the user. Examples include the disclosure of personal information such as credit card numbers and medical files.
<b>Active</b>	Active attacks include attempts to circumvent or break protection features, introduce malicious code, or steal or modify information. These attacks may be mounted against a network backbone, exploit information in transit, electronically penetrate an enclave, or attack an authorized remote user during an attempt to connect to an enclave. Active attacks can result in the disclosure or dissemination of data files, denial of service, or modification of data.
<b>Close-In</b>	Close-in attack consists of a regular type individuals attaining close physical proximity to networks, systems, or facilities for the purpose of modifying, gathering, or denying access to information. Close physical proximity is achieved through surreptitious entry, open access, or both.
<b>Insider</b>	Insider attacks can be malicious or nonmalicious. Malicious insiders intentionally eavesdrop, steal or damage information, use information in a fraudulent manner, or deny access to other authorized users. Nonmalicious attacks typically result from carelessness, lack of knowledge, or intentional circumvention of security for such reasons as “getting the job done.”
<b>Distribution</b>	Distribution attacks focus on the malicious modification of hardware or software at the factory or during distribution. These attacks can introduce malicious code into a product, such as a back door to gain unauthorized access to information or a system function at a later date.

The relationship of these attack classes to the information infrastructure areas is shown in Figure 2-3. Later sections of the IATF will provide an overview of the IA strategy for countering or mitigating the effects of these attacks.

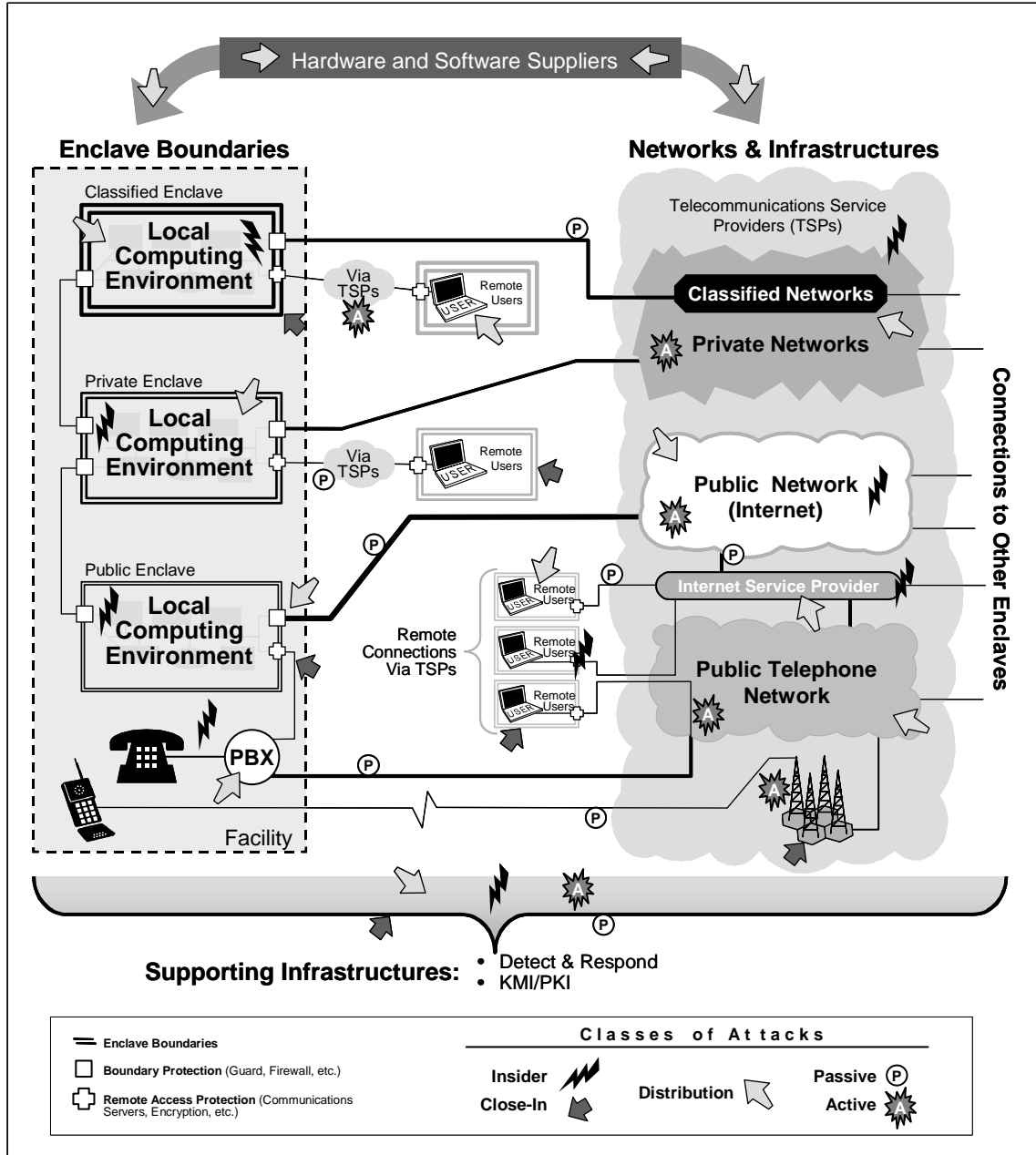

Figure 2-3. Classes of Attacks on the Information Infrastructure

## 2.3 People, Technology, Operations

IA is achieved when there is confidence that information and information systems are protected against attacks through the application of security services in such areas as availability, integrity, authentication, confidentiality, and nonrepudiation. The application of these services should be based on the protect, detect, and react paradigm. This means that in addition to incorporating protection mechanisms, organizations must expect attacks and must also incorporate attack-detection tools and procedures that allow them to react to and recover from these attacks.

Figure 2-4 depicts an important principle of the Defense in Depth strategy: the achievement of IA requires a balanced focus on three primary elements—people, technology, and operations.

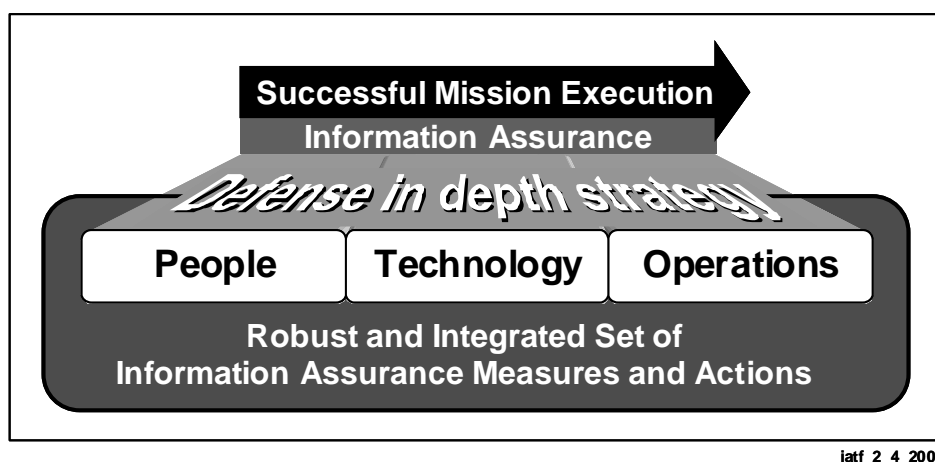

Figure 2-4. Defense in Depth Strategy

### 2.3.1 People

The achievement of IA begins with a senior-level management commitment (typically at the chief information officer level) based on a clear understanding of the perceived threat. This commitment must be followed by establishment of effective IA policies and procedures, assignment of roles and responsibilities, commitment of resources, training of critical personnel (e.g., users and system administrators), and enforcement of personal accountability. These steps include the establishment of physical security and personnel security measures to control and monitor access to facilities and critical elements of the IT environment.

Figure 2-5 lists some of the disciplines associated with people in the Defense in Depth strategy.

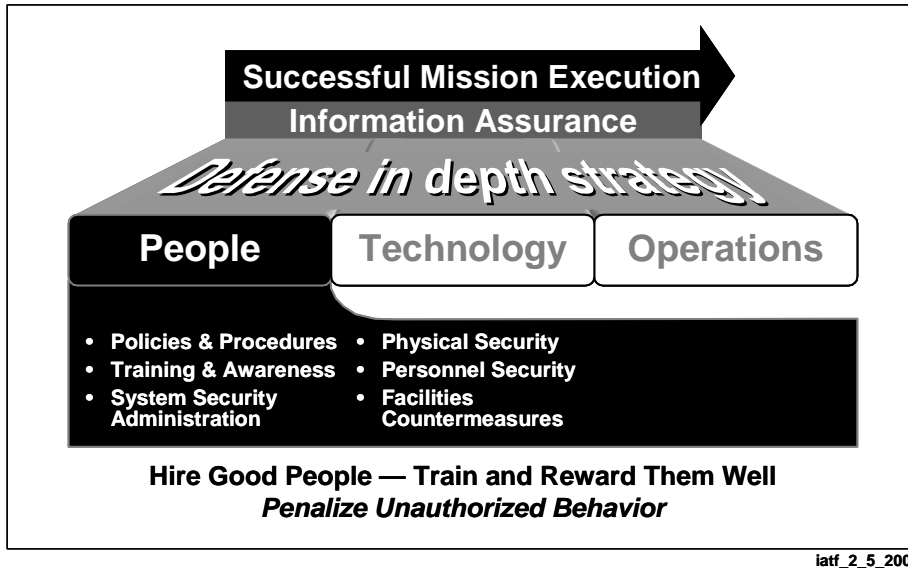

Figure 2-5. Defense in Depth Strategy—People

## 2.3.2 Technology

A wide range of technologies are available for providing IA services and for detecting intrusions. To ensure that the right technologies are procured and deployed, an organization should establish effective policies and processes for technology acquisition. These policies and processes should include security policy, IA principles, system-level IA architectures and standards, criteria for needed IA products, acquisition of products that have been validated by a reputable third party, configuration guidance, and processes for assessing the risk of the integrated systems. Figure 2-6 lists some of the technology areas addressed in the Defense in Depth strategy.

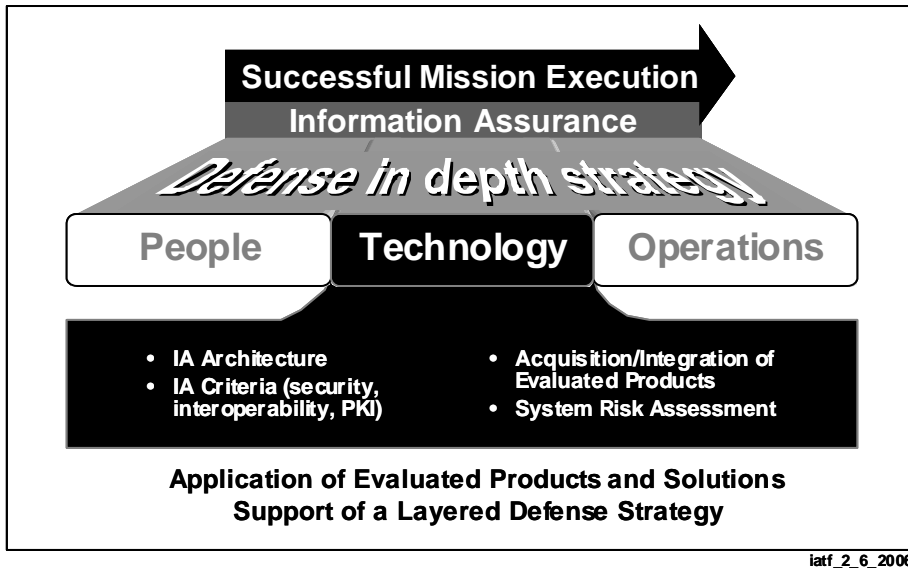
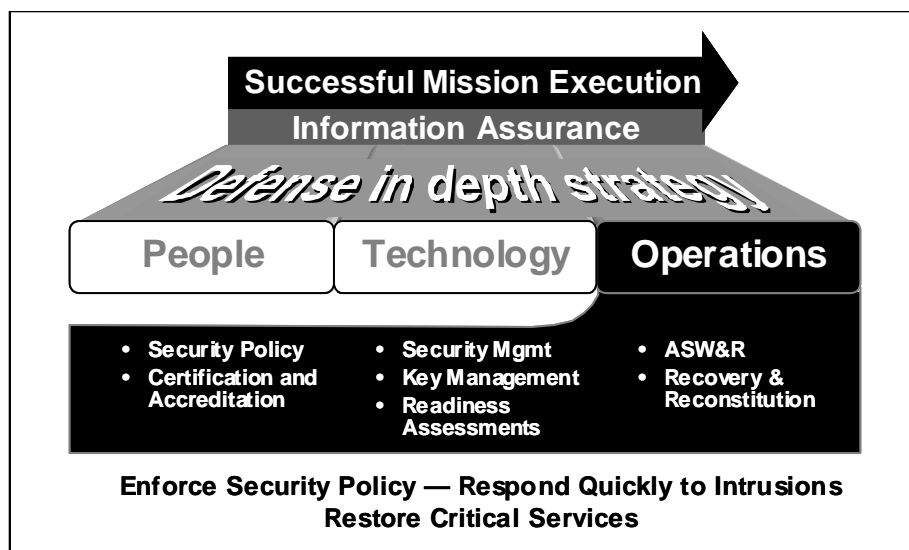

Figure 2-6. Defense in Depth Strategy—Technology

## 2.3.3 Operations

The operations element of the strategy focuses on all activities required to sustain an organization's security posture on a day-to-day basis. Figure 2-7 lists some of the operational focus areas associated with the Defense in Depth strategy.



iatf\_2\_7\_2007

Figure 2-7. Defense in Depth Strategy—Operations

## 2.4 Defense in Depth Objectives Overview

The need for secure operations of information and communications systems is not new. However, as organizations' reliance on such systems increases, as entities strive for greater efficiency through shared resources, and as those who perpetrate threats become more numerous and more capable, the IA posture of systems and organizations grows ever more important. Deliberate investments of time, resources, and attention in implementing and maintaining an effective IA posture have never been more important or more challenging.

In implementing an effective and enduring IA capability or in adopting a Defense in Depth strategy for IA, organizations should consider—

- Taking into consideration the effectiveness of the information protection required, based on the value of the information to the organization and the potential impact that loss or compromise of the information would have on the organization's mission or business. IA decisions should be based on risk analysis and keyed to the organization's operational objectives.



## UNCLASSIFIED

Defense-in-Depth

IATF Release 3.1—September 2002

- Using a composite approach, based on balancing protection capability against cost, performance, operational impact, and changes to the operation itself considering both today's and tomorrow's operations and environments.
- Drawing from all three facets of Defense in Depth—people, operations, and technology. Technical mitigations are of no value without trained people to use them and operational procedures to guide their application.
- Establishing a comprehensive program of education, training, practical experience, and awareness. Professionalization and certification licensing provide a validated and recognized expert cadre of system administrators.
- Exploiting available commercial off-the-shelf (COTS) products and relying on in-house development for those items not otherwise available.
- Planning and following a continuous migration approach to take advantage of evolving information processing and network capabilities—both functional and security-related—and to ensure adaptability to changing organizational needs and operating environments.
- Assessing periodically the IA posture of the information infrastructure. Technology tools, such as automated scanners for networks, can assist in vulnerability assessments.
- Taking into account, not only the actions of those with hostile intent, but also inadvertent or unwitting actions that may have ill effects and natural events that may affect the system.
- Adhering to the principles of commonality, standardization, and procedures, and interoperability and to policies.
- Judiciously using emerging technologies, balancing enhanced capability with increased risk.
- Employing multiple means of threat mitigation, overlapping protection approaches to counter anticipated events so that loss or failure of a single barrier does not compromise the overall information infrastructure.
- Implementing and holding to a robust IA posture—one that can cope with the unexpected.
- Ensuring that only trustworthy personnel have physical access to the system. Methods of providing such assurance include appropriate background investigations, security clearances, credentials, and badges.
- Monitoring vulnerability listings and implementing fixes, ensuring that security mechanisms are interoperable, keeping constant watch over the security situation and mechanisms, properly employing and upgrading tools and techniques, and dealing rapidly and effectively with issues.

- Using established procedures to report incident information provided by intrusion detection mechanisms to authorities and specialized analysis and response centers.

The dominant need of the user community is ready access to the information infrastructure and the information it contains to support its operational objectives. This requires the use of robust information-processing technology and reliable connectivity. IA enables these capabilities by providing organizations with the ability to maintain adequate protection of their information.

The IATF focuses on the technology aspects of Defense in Depth. In developing an effective IA posture, all three components of the Defense in Depth strategy—people, technology, and operations—must be addressed.

The IATF organizes the presentation of IA technology objectives and approaches for the information infrastructure according to the four Defense in Depth technology focus areas: defend the computing environment, defend the enclave boundaries, defend the networks and infrastructure, and supporting infrastructures. These areas are shown in Figure 2-8. The technology objectives and approaches in these focus areas, explained in the sections that follow, address the needs of private and public, as well as civil and military, sectors of our society.

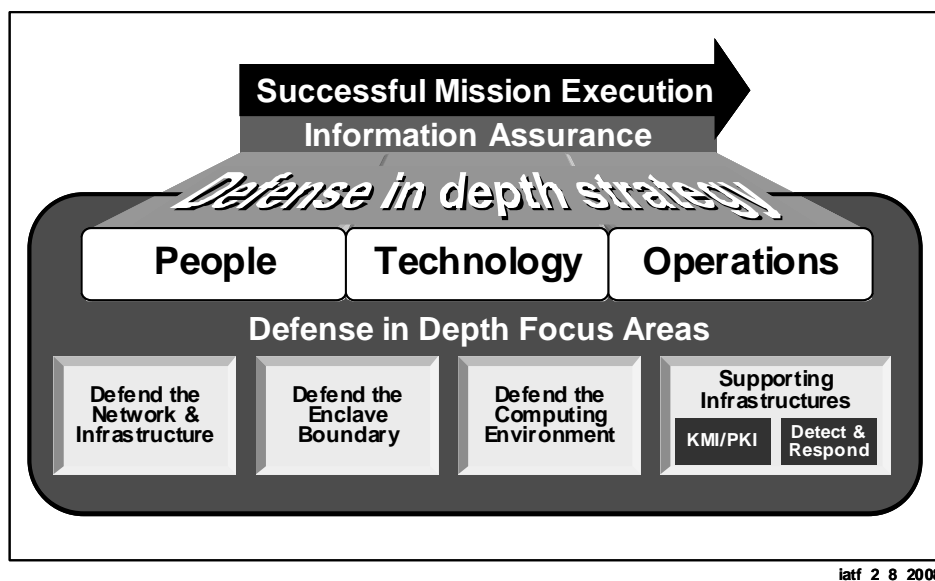

**Figure 2-8. Defense in Depth Focus Areas**

The Defense in Depth strategy recommends adherence to several IA principles—

- **Defense in Multiple Places.** Given that adversaries can attack a target from multiple points using insiders or outsiders, an organization must deploy protection mechanisms at multiple locations to resist all methods of attack.

At a minimum, these Defense in Depth locations should include—

## UNCLASSIFIED

Defense-in-Depth  
IATF Release 3.1—September 2002

- Defend the networks and infrastructure:
  - Protect local and wide area communications networks (e.g., from denial-of-service attacks).
  - Provide confidentiality and integrity protection for data transmitted over these networks (e.g., use encryption and traffic flow security measures to resist passive monitoring).
  - Ensure that all data exchanged over WAN is protected from disclosure to anyone not authorized to access the network.
  - Ensure that WANs supporting mission-critical and mission-support data provide appropriate protection against denial-of-service attacks.
  - Protect against the delay, misdelivery, or nondelivery of otherwise adequately protected information.
  - Protect from traffic flow analysis:
    - User traffic.
    - Network infrastructure control information.
  - Ensure that protection mechanisms do not interfere with otherwise seamless operation with other authorized backbone and enclave networks.
  
- Defend the enclave boundaries (e.g., deploy firewalls and intrusion detection to resist active network attacks).
  - Ensure that physical and logical enclaves are adequately protected.
  - Enable dynamic throttling of services in response to changing threats.
  - Ensure that systems and networks within protected enclaves maintain acceptable availability and are adequately defended against denial-of-service intrusions.
  - Ensure that data exchanged between enclaves or via remote access is protected from improper disclosure.
  - Provide boundary defenses for those systems within the enclave that cannot defend themselves due to technical or configuration problems.
  - Provide a risk-managed means of selectively allowing essential information to flow across the enclave boundary.
  - Provide protection against the undermining of systems and data within the protected enclave by external systems or forces.
  - Provide strong authentication, and thereby authenticated access control, of users sending or receiving information from outside their enclave.
  
- Defend the computing environment (e.g., provide access controls on hosts and servers to resist insider, close-in, and distribution attacks).
  - Ensure that clients, servers, and applications are adequately defended against denial of service, unauthorized disclosure, and modification of data.
  - Ensure the confidentiality and integrity of data processed by the client, server, or application, both inside and outside of the enclave.
  - Defend against the unauthorized use of a client, server, or application.
  - Ensure that clients and servers follow secure configuration guidelines and have all appropriate patches applied.

- Maintain configuration management of all clients and servers to track patches and system configuration changes.
  - Ensure that a variety of applications can be readily integrated with no reduction in security.
  - Ensure adequate defenses against subversive acts by trusted persons and systems, both internal and external.
- **Layered defenses.** Even the best available IA products have inherent weaknesses. As a result, an adversary will eventually find an exploitable vulnerability in almost any system. An effective countermeasure is to deploy multiple defense mechanisms between adversaries and their target. Each of these mechanisms must present unique obstacles to the adversary. Further, each should include both protection and detection measures. These measures help to increase risk (of detection) for the adversary while reducing his or her chances of success or making successful penetrations unaffordable. Deploying nested firewalls (each coupled with intrusion detection) at outer and inner network boundaries is an example of a layered defense. The inner firewalls may support more granular access control and data filtering. Table 2-2 provides other examples of layered defenses.

**Table 2-2. Examples of Layered Defenses**

Class of Attack	First Line of Defense	Second Line of Defense
<b>Passive</b>	Link and network layer and encryption and traffic flow security	Security-enabled applications
<b>Active</b>	Defend the enclave boundaries	Defend the computing environment
<b>Insider</b>	Physical and personnel security	Authenticated access controls, audit
<b>Close-In</b>	Physical and personnel security	Technical surveillance countermeasures
<b>Distribution</b>	Trusted software development and distribution	Run time integrity controls

- **Security robustness.** Specify the security robustness (strength and assurance) of each IA component as a function of the value of what it is protecting and the threat at the point of application.
- **Deploy KMI/PKI.** Deploy robust key management and public key infrastructures that support all of the incorporated IA technologies and that are highly resistant to attack. Provide a cryptographic infrastructure that supports key, privilege, and certificate management and that enables positive identification of individuals using network services.
- **Deploy intrusion detection systems.** Deploy infrastructures to detect intrusions, to analyze and correlate the results, and to react as needed. These infrastructures should help the Operations staff to answer questions such as “Am I under attack?” “Who is the source?” “What is the target?” “Who else is under attack?” “What are my options?”

- Provide an intrusion detection, reporting, analysis, assessment, and response infrastructure that enables rapid detection and response to intrusions and other anomalous events and provides operational situation awareness.
- Plan execution and reporting requirements for contingencies and reconstitution.

## 2.5 Additional Resources

The National Security Agency (NSA), with support from other U.S. government agencies and U.S. industry, has undertaken several initiatives to support the Defense in Depth strategy. These include—

- **The IATF and the IATF Forum ([www.iatf.net](http://www.iatf.net)).** This document and the associated forum provide a means for the Government and industry to encourage a dialogue on IA issues.
- **The National Information Assurance Partnership (NIAP).** This is a partnership between NSA and the National Institute of Standards and Technology (NIST) to foster development of the International Common Criteria (an ISO standard) and to accredit commercial laboratories to validate the security functions in vendors' products. Information on this activity is available at <http://niap.nist.gov>.
- **Common Criteria Protection Profiles.** These documents recommend security functions and assurance levels based on the Common Criteria. They are available for a wide range of commercially available technologies and can be accessed at the IATF Web site ([www.iatf.net](http://www.iatf.net)) or the NIAP Web site (listed above).
- **List of Evaluated Products.** These are lists of commercial IA products that have been evaluated against the Common Criteria. The lists are maintained by NIST and are available at the NIAP Web site.
- **Configuration Guidance.** These documents, prepared by NSA, contain recommended configurations for a variety of commonly used commercial products. These documents can be found at <http://nsa1.www.conxion.com>.
- **Glossary.** *The National Information Systems Security (INFOSEC) Glossary* (September 2000) can be found at <http://www.nstissc.gov/Assets/pdf/4009.pdf>

# Chapter 3

## The Information Systems Security Engineering Process

---

Information Systems Security Engineering (ISSE) is the art and science of discovering users' information protection needs and then designing and making information systems, with economy and elegance, so they can safely resist the forces to which they may be subjected. This chapter describes an ISSE process for discovering and addressing users' information protection needs. The ISSE process should be an integral part of systems engineering (SE) and should support certification and accreditation (C&A) processes, such as the Department of Defense (DoD) Information Technology Security Certification and Accreditation Process (DITSCAP). The ISSE process provides the basis for the background information, technology assessments, and guidance contained in the remainder of the Information Assurance Technical Framework (IATF) document and ensures that security solutions are effective and efficient.

### 3.1 Introduction

This chapter is organized into five sections, as follows:

- Section 3.1, Introduction.
- Section 3.2, Discussion of three important SE and ISSE principles.
- Section 3.3, Description of ISSE activity in the context of a generic SE process.
- Section 3.4, Correlation between the ISSE process and standard examples of SE processes.
- Section 3.5, Relationship of ISSE to DITSCAP.

The generic SE process that forms the basis for describing the ISSE process comprises the following activities:

- Discover Needs.
- Define System Requirements.
- Design System Architecture.
- Develop Detailed Design.
- Implement System.
- Assess Effectiveness

The dependencies (i.e., direction of information flow) between these activities are shown in Figure 3-1. Arrows indicate the flow of information between the activities but not necessarily

their sequence or timing. Although not an activity, the Users/Users' Representatives element is a reminder that throughout the process there is continual interaction and feedback between the systems engineer or information systems security engineer and the users.

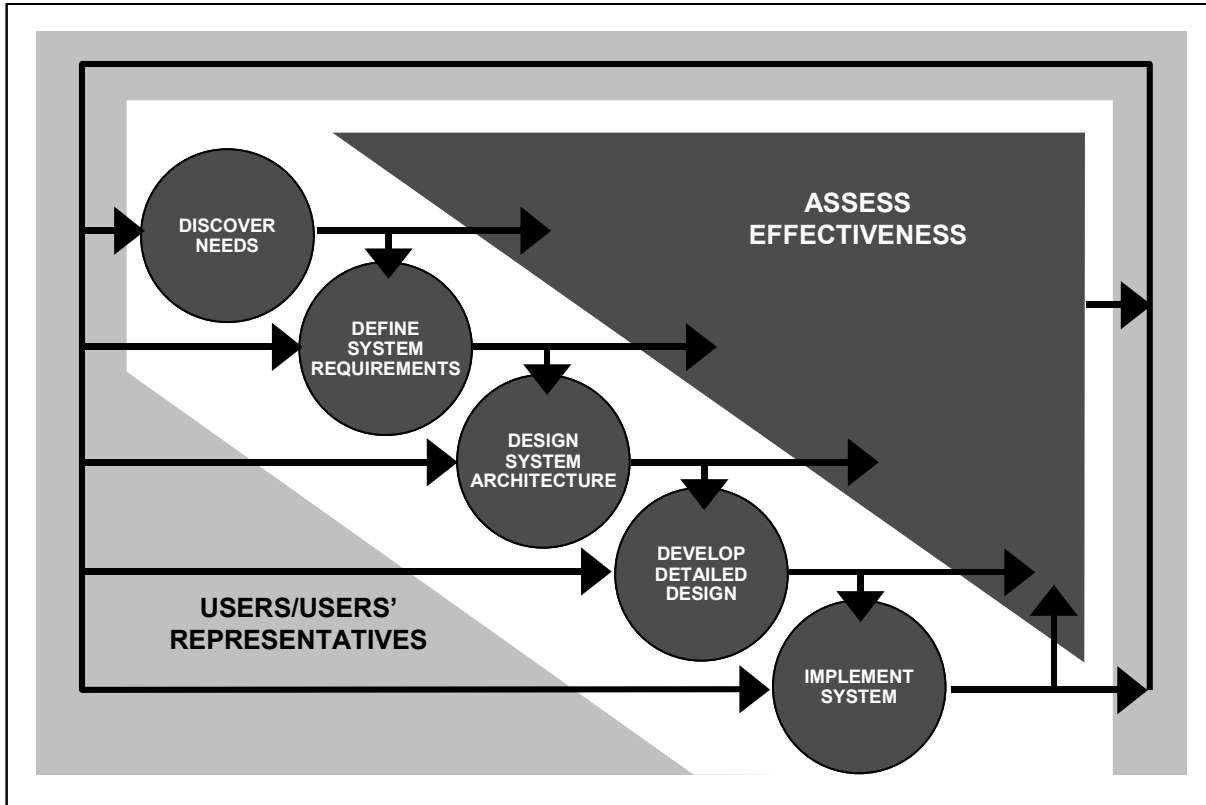

iatf\_3\_1\_3001

**Figure 3-1. Generic Systems Engineering Process**

This SE process diagram shown in Figure 3-1 differs from others the reader may have seen in its emphasis on the provision of SE assistance over the entire development life cycle, including needs discovery, system implementation, and assessment of system effectiveness. The Discover Needs activity is often a predecessor to the SE process, rather than a part of that process, because the systems engineer's customer usually performs this activity as part of an acquisition process. However, because information protection needs are seldom identified during the customer's process, Discover Needs and the corresponding ISSE activity, Discover Information Protection Needs, are included here.

Similarly, the Implement System activity is not included in all SE process descriptions because at that stage the focus has changed from engineering to building, integrating, and testing. Nevertheless, configuring the components and the system correctly and training users and administrators are critical to achieving the required information protection; therefore, Implement System and the corresponding ISSE activity, Implement System Security, are included as well.

Most SE processes address system effectiveness issues throughout the development life cycle. In the diagram in Figure 3-1 Assess Effectiveness is explicitly shown to emphasize the interaction

with the user organization in establishing mission needs and defining measures-of-effectiveness before designing the system, and in assessing the effectiveness of the system, as designed, developed, and implemented, in satisfying those needs.

All of the ISSE activities that correspond to the SE activities in Figure 3-1 are listed and described in Table 3-1.

**Table 3-1. Corresponding SE and ISSE Activities**

SE Activities	ISSE Activities
<p><b>Discover Needs</b></p> <p>The systems engineer helps the customer understand and document the information management needs that support the business or mission. Statements about information needs may be captured in an information management model (IMM).</p>	<p><b>Discover Information Protection Needs</b></p> <p>The information systems security engineer helps the customer understand the information protection needs that support the mission or business. Statements about information protection needs may be captured in an Information Protection Policy (IPP).</p>
<p><b>Define System Requirements</b></p> <p>The systems engineer allocates identified needs to systems. A system context is developed to identify the system environment and to show the allocation of system functions to that environment. A preliminary system Concept of Operations (CONOPS) is written to describe operational aspects of the candidate system (or systems). Baseline requirements are established.</p>	<p><b>Define System Security Requirements</b></p> <p>The information systems security engineer allocates information protection needs to systems. A system security context, a preliminary system security CONOPS, and baseline security requirements are developed.</p>
<p><b>Design System Architecture</b></p> <p>The systems engineer performs functional analysis and allocation by analyzing candidate architectures, allocating requirements, and selecting mechanisms. The systems engineer identifies components or elements, allocates functions to those elements, and describes the relationships between the elements.</p>	<p><b>Design System Security Architecture</b></p> <p>The information systems security engineer works with the systems engineer in the areas of functional analysis and allocation by analyzing candidate architectures, allocating security services, and selecting security mechanisms. The information systems security engineer identifies components or elements, allocates security functions to those elements, and describes the relationships between the elements.</p>
<p><b>Develop Detailed Design</b></p> <p>The systems engineer analyzes design constraints, analyzes trade-offs, does detailed system design, and considers life-cycle support. The systems engineer traces all of the system requirements to the elements until all are addressed. The final detailed design results in component and interface specifications that provide sufficient information for acquisition when the system is implemented.</p>	<p><b>Develop Detailed Security Design</b></p> <p>The information systems security engineer analyzes design constraints, analyzes trade-offs, does detailed system and security design, and considers life-cycle support. The information systems security engineer traces all of the system security requirements to the elements until all are addressed. The final detailed security design results in component and interface specifications that provide sufficient information for acquisition when the system is implemented.</p>



SE Activities	ISSE Activities
<p style="text-align: center;"><b>Implement System</b></p> <p>The systems engineer moves the system from specifications to the tangible. The main activities are acquisition, integration, configuration, testing, documentation, and training. Components are tested and evaluated to ensure that they meet the specifications. After successful testing, the individual components—hardware, software, and firmware—are integrated, properly configured, and tested as a system.</p>	<p style="text-align: center;"><b>Implement System Security</b></p> <p>The information systems security engineer participates in a multidisciplinary examination of all system issues and provides inputs to C&amp;A process activities, such as verification that the system as implemented protects against the threats identified in the original threat assessment; tracking of information protection assurance mechanisms related to system implementation and testing practices; and providing inputs to system life-cycle support plans, operational procedures, and maintenance training materials.</p>
<p style="text-align: center;"><b>Assess Effectiveness</b></p> <p>The results of each activity are evaluated to ensure that the system will meet the users' needs by performing the required functions to the required quality standard in the intended environment. The systems engineer examines how well the system meets the needs of the mission.</p>	<p style="text-align: center;"><b>Assess Information Protection Effectiveness</b></p> <p>The information systems security engineer focuses on the effectiveness of the information protection—whether the system can provide the confidentiality, integrity, availability, authentication and nonrepudiation for the information it is processing that is required for mission success.</p>

## 3.2 Principles

Nothing is more inefficient than solving the wrong problem and building the wrong system. In this section, we discuss three important principles that will help avoid this inefficiency. These principles are—

1. Always keep the problem and solution spaces separate.
2. The problem space is defined by the customer's mission or business needs.
3. The systems engineer and information systems security engineer define the solution space, driven by the problem space.

Principle 1: Always keep the problem and the solution spaces separate.

The problem is *what* we want the system to do. The solution is *how* the system will do what we want it to do. When we focus on the solution, it is easy to lose sight of the problem. This can lead to solving the wrong problem and building the wrong system. As we have noted, *nothing is more inefficient than solving the wrong problem and building the wrong system.*

Principle 2: The problem space is defined by the customer's mission or business needs.

Often customers talk to engineers in terms of technology and their notion of solutions to their problems, rather than in terms of the problem. Systems engineers and information systems security engineers must set these notions aside and discover the customer's underlying problem. If the user requirements are not based on the customer's mission or business needs, the resulting system solution is not likely to respond to those needs. Again, this will lead to building the wrong system, and *nothing is more inefficient than solving the wrong problem and building the wrong system.*

Principle 3: The systems engineer and information systems security engineer define the solution space, driven by the problem space.

The systems engineer, not the customer, is the expert on system solutions. If the customer were the design expert, there would be no need to hire the systems engineer. A customer who insists on intervening in the design process may place constraints on the solution and limit the flexibility of the systems engineer in developing a system that supports the mission or business goals and meets the users' requirements.

In summary, the customer owns the problem. It is the customer's mission or business that the system is intended to support. However, the customer is not always the expert in discovering and documenting the problem. The engineers should help the customer with discovering and documenting the problem. At the same time the systems engineer, not the customer, is the expert in designing solutions. The systems engineers and information systems security engineers should resist the customer's tendency to intervene in design.

## 3.3 Process

The ISSE process section covers six activities that correspond to a generic SE process:

- Discover Information Protection Needs (Discover Needs).
- Define System Security Requirements (Define System Requirements).
- Design System Security Architecture (Design System Architecture).
- Develop Detailed Security Design (Develop Detailed Design).
- Implement System Security (Implement System).
- Assess Information Protection Effectiveness (Assess Effectiveness).

The ISSE process and its SE context are described in detail below.

### 3.3.1 Discover Information Protection Needs

Discover Information Protection Needs is the first activity of the ISSE process. The corresponding SE activity is Discover Needs (see Figure 3-1). If the Discover Needs activity is not being performed or is incomplete, the information systems security engineer must complete the following SE tasks:

- Develop an understanding of the customer's mission or business.
- Help the customer determine what information management is needed to support the mission or business.
- Create a model of that information management, with customer concurrence.
- Document the results as the basis for defining information systems that will satisfy the customer's needs.

## UNCLASSIFIED

The Information Systems Security Engineering Process  
IATF Release 3.1—September 2002

To understand the customer's mission or business, information systems security engineers must take advantage of all available source material, such as operational doctrine,<sup>1</sup> Web pages, annual reports, and proprietary documentation. The mission or business may be summarized in documents such as a mission needs statement (MNS) or a high-level version of a Concept of Operations (CONOPS), but the most important source of information is direct contact with the customer.

Underlying the customer's mission or business is the information management that supports operations. The first operational elements a customer will think of are the products and services the operation provides, but systems engineers must also seek other important support functions, such as command and control, logistics, human resources, finance, research and development, management, marketing, and manufacturing.

To define information management needs, a model is developed that identifies processes, the information being processed, and the users of the information and the processes. This modeling is in effect a structured analysis that decomposes user roles, processes, and information until ambiguity is reduced to a satisfactory degree. An important step in this modeling is to apply "least privilege" rules, by which users are limited to the processes and information they need to do their jobs. The model should also include the requirements of any information management policies, regulations, and agreements that apply to the information being managed. The main components of the model are information domains, each of which identifies three elements:

- Users or members of the information domain.
- Rules, privileges, roles, and responsibilities that apply to the users in managing all the information.
- Information objects being managed, including processes.

The model, then, is a collection of information domains. The resulting document, the IMM, is usually a very detailed representation of information management needs. The information systems security engineer may support the systems engineer in developing the IMM. This part of the Discover Information Protection Needs activity is presented in detail in the protection needs elicitation (PNE) appendix to this IATF. See Figure 3-2 for an illustration of Discover Information Protection Needs.

Once the IMM is complete, the information systems security engineer can use this knowledge to identify applicable protection policies, security regulations, directives, laws, etc. These documents may identify required levels of security (for example National Security Agency [NSA] approved cryptography for classified information), or C&A procedures that must be followed.

---

<sup>1</sup> Operational doctrine, as used here, is a set of documents that describe how an organization conducts its mission. It should not be confused with security doctrine, which is an architectural element that describes secure procedures for systems.

A critical part of the Discover Information Protection Needs activity is defining threats to the information. With the customer as the best source of knowledge, and informed by the information systems security engineer's expertise, each information domain is assigned metrics for harm to information (HTI) and potentially harmful events (PHE). HTI considers the value of the information and the degree of harm to the mission if the information were disclosed, modified, destroyed, or unavailable when needed. PHE considers the existence of malicious adversaries, their degree of motivation, and the potential for accidents and natural disasters. Each information domain then has an HTI and a PHE assigned for disclosure, modification, destruction, and unavailability. The HTIs and PHEs are then combined to produce a single information threat metric, such as 3, 2, 1, and 0, with 0 representing no threat. The actual choice of metrics and the method of combining them must be understandable and acceptable to the customer. One recommendation for choosing and combining these metrics is given in the PNE appendix to the IATF.

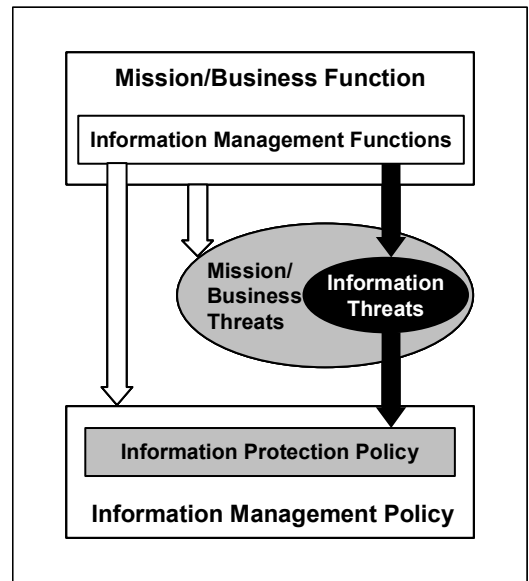

iatt\_3\_2\_0079

**Figure 3-2. Discover Needs**

The ISSE process defines the security services and the strengths of service using the information threat as a guideline for setting protection priorities. The information systems security engineer and the customer apply confidentiality, integrity, availability, access control, identification and authentication (I&A), nonrepudiation, and security management services, as appropriate to each information threat. The strengths of the services are proportional to the information threat metrics.

Documentation is crucial in all stages of SE and ISSE. In this activity, the information systems security engineer documents information threats; security services, strengths, and priorities; and roles and responsibilities. The information threats and the corresponding security services in the system or systems used to support the customer's mission or business are documented in an IPP. When customer concurrence is obtained, the IPP is assumed to be part of the customer's information management policy. This policy will be the basis for assessing the effectiveness of the information protection throughout the remainder of the process activities. Figure 3-2 illustrates the flow from mission or business to the IPP.

Early in the engineering process, the information systems security engineer also should begin documenting design constraints. These may be found in the legal and regulatory requirements identified earlier or they may be inherited from legacy systems that must interface with the target system. In either case, they must be documented and tracked throughout the SE/ISSE process.

The information systems security engineer is responsible for presenting the process, summarizing the information model, identifying the threats and security services, and determining the threats' and services' relative strengths and priorities to the customer. Since this

documents the customer's information management and protection needs, on which all further development efforts will be based, customer agreement on the conclusions reached in this activity is essential and is the measure of the effectiveness of the information systems security engineer's efforts. In each activity of the ISSE process, the information systems security engineer will perform activities to support the C&A of the system. In the Discover Information Protection Needs activity, the focus is on identifying the key roles (i.e., Designated Approving Authority [DAA]/Accreditor and Certification Authority/Certifier) and the process to be used for C&A and acquisition of the system, and on obtaining concurrence in the documented results of this activity, as required.

### 3.3.2 Define System Security Requirements

In this activity, which is part of the Define System Requirements activity of SE, the information systems security engineer considers one or more solution sets that can meet the information protection needs expressed by the customer and documented in the IPP. The mapping of needs to a solution set is illustrated in Figure 3-3. Each solution set includes a system concept for the target system, which defines the following:

- System context.
- Preliminary CONOPS.
- System requirements (what the system is to accomplish).

With customer involvement, one solution set is chosen and its system context, CONOPS, and requirements are documented. This activity can result in the need to modify existing systems or to develop more than one target system. Figure 3-3 also illustrates the allocation of needs to systems other than the target system. Examples of external systems include a system that provides a Public Key Infrastructure (PKI) and a system for security clearances of users.

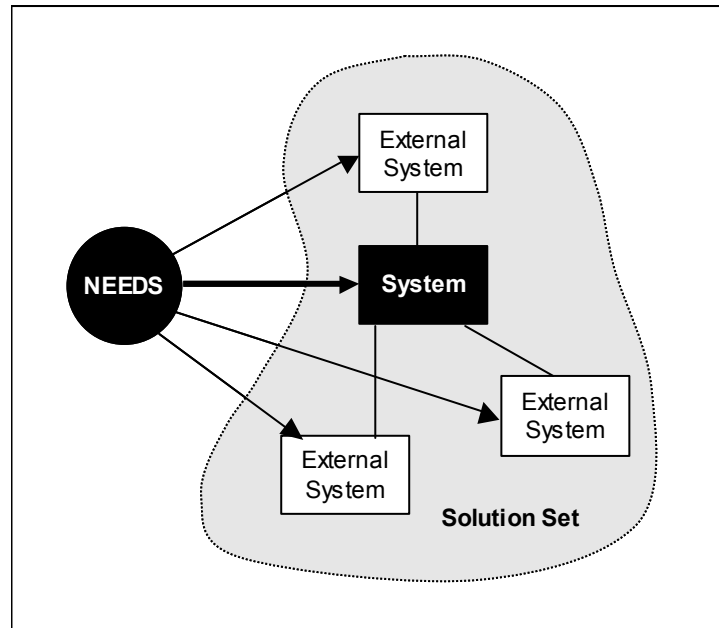

Figure 3-3. Allocation of Needs into a Solution Set

iatf\_3\_3\_0080

Developing the system security context involves defining system boundaries and interfaces with SE, allocating security functions to target or external systems, and identifying data flows between the target and external systems and protection needs associated with those flows. Information management needs (per the IMM) and information protection needs (per the IPP) are allocated to the target system and to external systems; allocations to external systems are assumptions that must be accepted by these systems' owners. The system security context

documents those allocations and specifies data flows between the system and external systems and how they are controlled.

A preliminary security CONOPS describes, from a user perspective, what information management and information protection functions the system will perform in support of the mission, but falls short of defining step-by-step procedures. The CONOPS will define the reliance of mission or business needs on other systems and the products and services they deliver. The system security context and CONOPS are coordinated with the systems engineer, the customer, and owners of external systems.

The information systems security engineer works with the systems engineers to define system security requirements, system security modes of operation, and system security performance measures. Good system requirements specify what a system must do, without specifying its design or implementation. The systems engineer and the information systems security engineer must ensure that the requirements are understandable, unambiguous, comprehensive, complete, and concise. Requirements analysis must clarify and define functional requirements and design constraints. Functional requirements define quantity (how many), quality (how good), coverage (how far), timelines (when and how long), and availability (how often). Any performance requirements and residual design constraints are carried forward as part of the system requirements document. Design constraints are not independent of implementation but represent design decisions or partial system design. In system requirements documents, design constraints should be identified separately from system interface requirements, which must be documented, including any that are imposed by external systems. Design constraints define factors that limit design flexibility, such as environmental conditions or limits; defense against internal or external threats; and contract, customer, or regulatory standards. When the system requirements are approved, they are documented to give designers a baseline for system development.

In analyzing requirements, the systems engineer reviews the traceability documentation to ensure that all of the needs discovered have been allocated either to the target system or to external systems and that the context for the target system describes all external interfaces and flows. The systems engineer also ensures that the preliminary system CONOPS covers all of the functionality, missions, or business needs and addresses the inherent risk in operating the system.

The information systems security engineer ensures that the selected solution set meets the mission or business security needs, coordinates the system boundaries, and ensures that the security risks are acceptable. The information systems security engineer will present security context, security CONOPS, and system security requirements to the customer and gain concurrence.

All documentation of the system concept and any rationale for choosing that concept are delivered in compliance with the C&A process. The information systems security engineer is responsible for ensuring that Accreditor and Certifier concurrence is obtained as necessary.

### 3.3.3 Design System Security Architecture

In the Define System Requirements SE activity, requirements were allocated to an entire information system, indicating the functions to be performed without any definition of system components. In Design System Architecture, the SE team now does functional decomposition, choosing the types of components that will perform specific functions. This process is the core of designing an architecture. Figures 3-4a and 3-4b illustrate the contrast between these two SE activities where Define System Requirements treats the target system as a “black box” and Design System Architecture creates the structure within the system. The same contrast occurs in the corresponding ISSE activities—Define System Security Requirements and Design System Security Architecture.

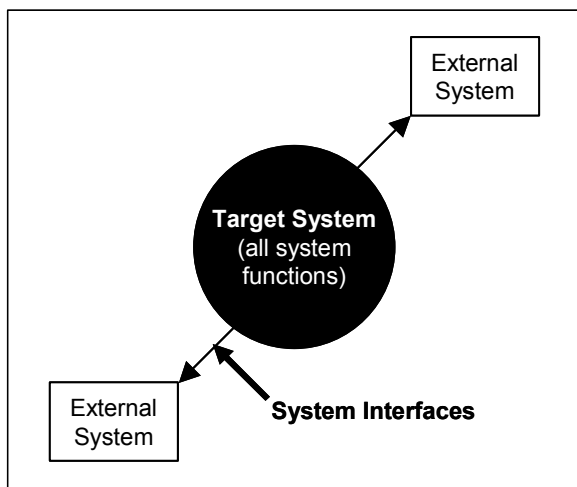

Figure 3-4a. Define System Requirements

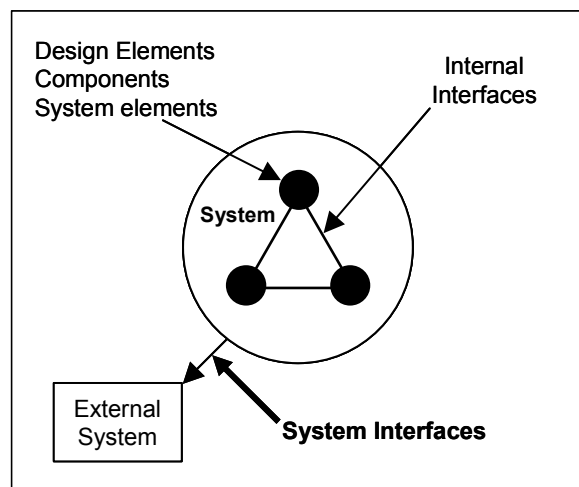

Figure 3-4b. Design System Architecture

Functions are analyzed by decomposing higher-level functions identified through requirements analysis into lower level functions. The performance requirements associated with the higher level are allocated to lower level functions. The result is a description of the product or item in terms of what it does logically and in terms of the performance required. This analysis includes candidate system architectures, function and process, interfaces (internal and external), elements (components), information transfers, environments, and users/accesses.

This description is often called the functional architecture of the product or item. Functional analysis and allocation allow a better understanding of what the system has to do; the ways in which it can do it; and to some extent, the priorities and conflicts associated with lower level functions. It provides information essential to optimizing physical solutions. Key tools in functional analysis and allocation are Functional Flow Block Diagrams, Timeline Analysis, and the Requirements Allocation Sheet.

During this task, the information systems security engineer works with the systems engineers to ensure that security requirements flow properly to the architecture and that architecture decisions do not impede security.

The information systems security engineer works to allocate security requirements to the target and external systems and to ensure that external systems identified can support what is allocated to them. This is particularly important for security, since services such as key management are often allocated to external systems.

The information systems security engineer will identify high-level security mechanisms during this task (e.g., encryption, digital signature). This is necessary so that dependencies, such as key management for encryption, can be addressed and allocated. The information systems security engineer should match mechanisms to security service strength, apply design constraints, analyze and document shortfalls, perform interdependency analysis, ascertain the feasibility of mechanisms, and assess any residual risk associated with the mechanisms. Specific implementations of the security mechanisms are not identified in the architecture, so detailed vulnerability and attack information is not available to support the formal risk analysis process. However, an experienced information systems security engineer can describe the expected vulnerabilities in potential components and can develop attack scenarios to use in the risk analysis process.

The risk analysis process ensures that the selected security mechanisms provide the required security services and helps explain to the customer how the security architecture meets the security requirements. The effectiveness of the architecture in meeting these requirements is based on the results of the risk analysis and whether the customer concurs with the recommended course of action at this stage of development.

The information systems security engineer supports C&A by coordinating the security architecture and the results of the risk analysis with the Accreditor and the Certifier.

### **3.3.4 Develop Detailed Security Design**

The development of the information protection design is iterative, involving interactions between the SE and ISSE teams and between systems and component engineers within the teams. Decisions leading to the recommended design involve continuous assessments by the ISSE team to compare the expected risk with the system security requirements. The system security requirements set priorities for protection that the ISSE team applies accordingly. The ISSE team produces the design documentation required by the C&A process. That documentation enables independent evaluation of the design by risk analysts who then provide feedback on vulnerabilities.

In Develop Detailed Security Design, the information systems security engineer will ensure compliance with the security architecture, perform trade-off studies, and define system security design elements, including—

- Allocating security mechanisms to system security design elements.
- Identifying candidate commercial off-the-shelf (COTS)/government off-the-shelf (GOTS) security products.
- Identifying custom security products.



## UNCLASSIFIED

The Information Systems Security Engineering Process  
IATF Release 3.1—September 2002

- Qualifying element and system interfaces (internal and external).
- Developing specifications (e.g., Common Criteria protection profiles).

The information protection design specifies the system and its components, but does not decide on specific components or vendors. The selection of specific components is part of the Implement System activity.

Some important aspects of the ISSE effort are as follows:

- Components include both technical and nontechnical mechanisms (e.g., doctrine).
- Design must satisfy customer-specified design constraints.
- Trade-offs must consider priorities, cost, schedule, performance, and residual security risks.
- Risk analysis must consider the interdependency of security mechanisms.
- Design documents should be under strong configuration control.
- Failures to satisfy security requirements must be reported to C&A authorities.
- Design should be traceable to the security requirements.
- Design should project the schedule and cost of long-lead items and life-cycle support.
- Design should include a revised security CONOPS.

In Develop Detailed Security Design, the information systems security engineer also reviews how well the selected security services and mechanisms counter the threats identified in the IPP by performing an interdependency analysis to compare desired to effective security service strengths. Once completed, the risk assessment results, particularly any identified mitigation needs and residual risk, are documented and shared with the customer to obtain concurrence.

### 3.3.5 Implement System Security

The objective of the Implement System SE activity is to acquire, integrate, configure, test, document, and train. Implement System moves the system from design to operations. This activity concludes with a final system effectiveness assessment in which evidence is presented that the system complies with the requirements and satisfies the mission needs. Issues across all SE primary functions must be considered and any interdependency or trade-off issues resolved.

During Implement Systems Security, the information systems security engineer provides—

- Inputs to C&A process activities.
- Verification that the system as implemented does protect against the threats identified in the original threat assessment.

## UNCLASSIFIED

The Information Systems Security Engineering Process  
IATF Release 3.1—September 2002

- Tracking of, or participation in, application of information protection assurance mechanisms related to system implementation and testing practices.
- Inputs to and review of evolving system life cycle support plans, operational procedures, and maintenance training materials.
- A formal information protection assessment in preparation for the final system effectiveness assessment.
- Participation in the multidisciplinary examination of all system issues.

These efforts and the information each produces support the final system effectiveness assessment. Security accreditation approval typically occurs shortly after the conclusion of the final system effectiveness assessment.

Selecting specific products for integration into the security solution is part of the Implement System Security activity. These products can be acquired by purchase, lease, or borrowing. Selection will be based on factors such as cost of the component, availability, form, and fit. Other factors may include components affect on reliability of the particular system, risk to system performance if component performance is marginal, and future availability of the component or substitutes. Components that cannot be procured must be built. Whether software, hardware, or firmware, components should be verified as corresponding to the design specifications, and the verification must be formally documented. Any deviation must be evaluated for impact on the achievement of design and mission or business objectives, including security.

Components, whether procured or built, must be integrated into the system as designed, and any incompatibility with existing components resolved. Systems are often a hybrid of procured and built components that may need “glue,” such as software or interface cabling. During installation and configuration, functions that are needed should be implemented and functions that are not needed for the mission should be restricted.

The information systems security engineer must verify that the evaluation criteria for the security components measure the desired level of security and that the security components meet those criteria. Products may have been evaluated against Commercial COMSEC Evaluation Program (CCEP), National Information Assurance Partnership (NIAP), Federal Information Processing Standards (FIPS), or other NSA and National Institute of Standards and Technology (NIST) criteria.

The ISSE team helps configure the components to ensure that the security features are enabled and the security parameters are set to provide the required security services. Once the system is ready to be configured, any differences in settings that are necessary must be recorded and approved following configuration management procedures.

The systems and design engineers will write test procedures reflecting the results expected as the design solution becomes defined. As components are acquired, they should be unit tested. Verification of the design and interfaces ensures that the produced component operates correctly.

## UNCLASSIFIED

The Information Systems Security Engineering Process  
IATF Release 3.1—September 2002

Procedures must test all of the interfaces. If the system is unique or is to be operated in an environment that is difficult to model, however, it may not be possible to fully test all interfaces until the system is installed.

Integration testing verifies subsystem and system performance. Planning for testing should consider the people, tools, facilities, schedule, and capital resources required to test both individual components and the entire system. As components are integrated into the system and tested to ensure that the subsystems and the system are functional, some components may have to be changed. Test reports should document both positive and negative results of the testing.

Design documentation and experience in implementing a system are sources of material for training users and administrators. All documentation should be under strict version control. Training materials and instruction should address operational policy as it pertains to the system and should deal with system limitations as well as functions.

As the system is integrated and tested, it is important to document installation, operation, maintenance, and support procedures. These procedures will be based on the requirements, architecture, design, and test results of the system “as-built” configuration. As installation proceeds, it is important to document defects in the procedures and to note how changes may affect function and mission objectives. The impact of installation changes on the residual risk associated with operating, supporting, and maintaining the system should also be assessed.

The information systems security engineer will develop the information protection-related test plans and procedures and may have to develop test cases, tools, hardware, and software to exercise the system adequately. ISSE activities to this end include—

- Participation in the testing of protection mechanisms and functions.
- Tracking and applying information protection assurance mechanisms related to system implementation and testing practices.
- Providing inputs to and review of evolving life-cycle security support plans, including logistics, maintenance, and training.
- Continuing risk management.
- Supporting the C&A processes.

The information systems security engineer monitors the system security aspects of interfaces, integration, configuration, and documentation. System test and evaluation may reveal unexpected vulnerabilities; the risks and possible mission impacts associated with these vulnerabilities must be evaluated. The results are fed back to the design engineers in an iterative process. The information systems security engineer coordinates with the Certifiers and Accreditors to ensure the completeness of the required documentation. The information systems security engineer also monitors tasks to ensure that the security design is implemented correctly. To accomplish this, he or she will observe and participate in testing and analyze test and evaluation results.

During this task, the risk analysis will be initially conducted or updated. Strategies will be developed to mitigate identified risks and the information systems security engineer will identify possible mission impacts and advise the customer and the customer’s Certifiers and Accreditors.

The information systems security engineer ensures that the documentation necessary for C&A is completed and delivered. This documentation will include integration and test reports showing any variations to specifications. The information systems security engineer may contribute to and review these documents.

The ISSE team helps ensure that adequate training material is available for security training. Users must be advised of threats to the operation. Threat information and security responsibilities should be part of the system doctrine and any operational security policy.

### 3.3.6 Assess Information Protection Effectiveness

The Assess Information Protection Effectiveness activity spans the entire SE/ISSE process. Therefore, it is discussed in each of the preceding activity sections, as appropriate. A summary of the effectiveness assessment tasks related to the various other ISSE activities is provided in Table 3-2.

**Table 3-2. Assess Information Protection Effectiveness Tasks by ISSE Activity.**

ISSE Activity	Assess Information Protection Effectiveness Task
Discover Information Protection Needs	<ul style="list-style-type: none"> <li>• Present an overview of the process.</li> <li>• Summarize the information model</li> <li>• Describe threats to the mission or business through information attacks</li> <li>• Establish security services to counter those threats and identify their relative importance to the customer.</li> <li>• Obtain customer agreement on the conclusions of this activity as a basis for determining system security effectiveness.</li> </ul>
Define System Security Requirements	<ul style="list-style-type: none"> <li>• Ensure that the selected solution set meets the mission or business security needs.</li> <li>• Coordinate the system boundaries.</li> <li>• Present security context, security CONOPS, and system security requirements to the customer and gain their concurrence.</li> <li>• Ensure that the projected security risks are acceptable to the customer.</li> </ul>
Design System Security Architecture	<ul style="list-style-type: none"> <li>• Begin the formal risk analysis process to ensure that the selected security mechanisms provide the required security services and to explain to the customer how the security architecture meets the security requirements.</li> </ul>
Develop Detailed Security Design	<ul style="list-style-type: none"> <li>• Review how well the selected security services and mechanisms counter the threats by performing an interdependency analysis to compare desired to effective security service strengths.</li> <li>• Once completed, the risk assessment results, particularly any mitigation needs and residual risk, will be documented and shared with the customer to obtain their concurrence.</li> </ul>

ISSE Activity	Assess Information Protection EffectivenessTask
Implement System Security	<ul style="list-style-type: none"> <li>• The risk analysis will be conducted/updated.</li> <li>• Strategies will be developed for the mitigation of identified risks</li> <li>• Identify possible mission impacts and advise the customer and the customer’s Certifiers and Accreditors.</li> </ul>

### 3.4 ISSE Relationship to Sample SE Processes

The ISSE process description in Section 3.3 used a generic SE process to provide context. This section relates the ISSE activities to two specific systems engineering and acquisition processes, DoD 5000.2-R; Mandatory Procedures for Major Defense Acquisition Programs (MDAP) and Major Automated Information System (MAIS) Acquisition Programs, and the IEEE Standard for Application and Management of the Systems Engineering Process (IEEE Std. 1220-1998). The purpose of this mapping, summarized here and presented in detail in Appendix J, ISSE Relationship to Sample SE Processes, is to help the reader who is familiar with these or similar processes to have a better understanding of the nature of the ISSE activities and of the SE skills involved. Appendix J also includes the ISSE Master Activity and Task List, which is a decomposition of the ISSE process activities into tasks and subtasks. Besides the six technical process activities, two program management activities are included: Plan Technical Effort and Manage Technical Effort. This list is used to map ISSE activities to SE processes.

However, information systems security engineers are cautioned to avoid using this mapping as the sole guide for aligning ISSE activities with a customer’s SE activities. When tailoring ISSE activities to specific project timelines, it is important to consider the technical and funding milestones where the future direction of the project will be decided and to ensure that the decision-makers have the security-relevant information to make those decisions. The information systems security engineer must also consider that important activities and milestones may have occurred before the ISSE process was applied, but because of the dependency between activities, all the ISSE activities must be performed to the extent required to support subsequent decisions. For example, the specification and assessment of security components are dependent on system security architecture and detailed system design and the final assessment of information protection effectiveness must be based on an understanding of the information protection needs.

DoD 5000.2-R, MDAPs and MAIS Acquisition Programs, describe the Systems Engineering Process (SEP) as a comprehensive, iterative, and recursive problem-solving process, applied sequentially, top down. Figure 3-5 presents a diagram of this process:

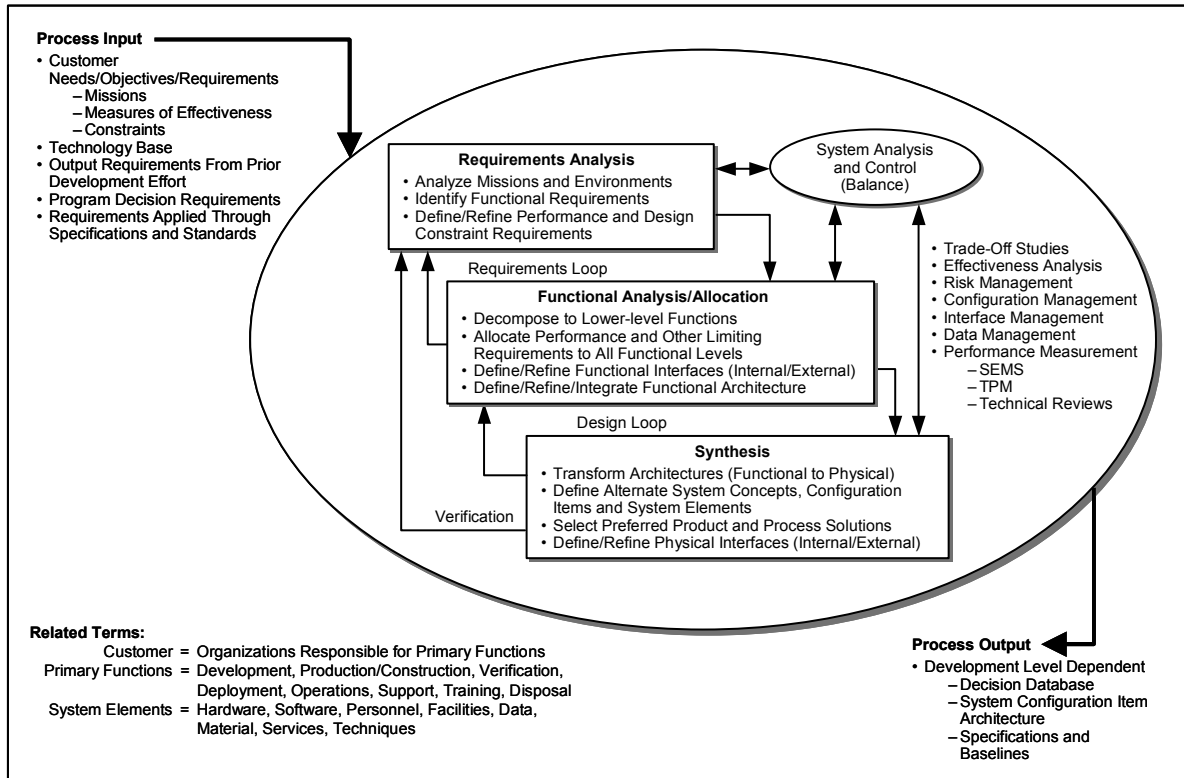

Figure 3-5. DoD 5000.2-R Systems Engineering Process

Figure 3-6 shows a diagram of IEEE Std 1220-1998.

### 3.5 Relationship of ISSE to DITSCAP

This section discusses the relationship of ISSE to DITSCAP. In general, the discussion also applies to ISSE’s relationship to other C&A processes.

The ISSE process helps the customer discover information protection needs to support the customer’s mission or business and helps build a system to meet those needs. Much of the information and analysis required by C&A processes can be gathered from the results of the ISSE process. Throughout these activities, the information systems security engineer works in support of the systems engineer, but must also satisfy the DAA.

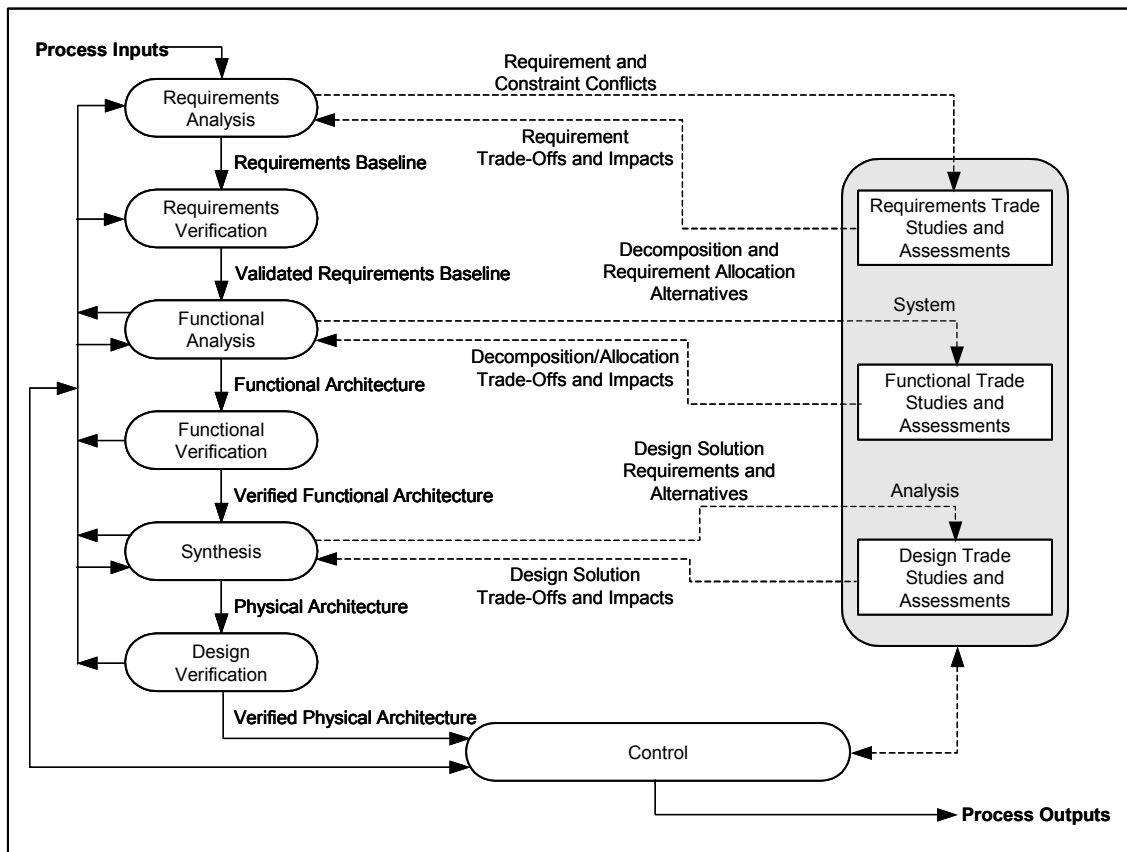

latf\_3\_6\_3006

Figure 3-6. IEEE Std 1220-1998 Systems Engineering Process

DITSCAP establishes a C&A process and sets out activities for collecting and evaluating evidence that will lead to the accreditation of an information system that meets the security requirements needed to support the customer’s mission or business. DITSCAP is a process for certifying that the information system not only meets documented security requirements but also will continue to do so. The key to the DITSCAP is the agreement between the information system’s program manager, the DAA, the Certifier, and the user’s representative. This agreement is documented in the System Security Authorization Agreement (SSAA).

Figure 3-7 shows that the development (SE/ISSE) process and the C&A process are separate, but related processes with distinct roles and outcomes. The SE/ISSE process results in system implementation and documentation; the C&A process results in certification documentation, a certification recommendation, and an accreditation decision. The SE/ISSE process produces evidence and documentation used by the C&A process. The C&A process provides feedback used by the SE/ISSE process. Both processes have one thing in common—the ultimate goal of an operational system that supports the user organization’s mission or business.

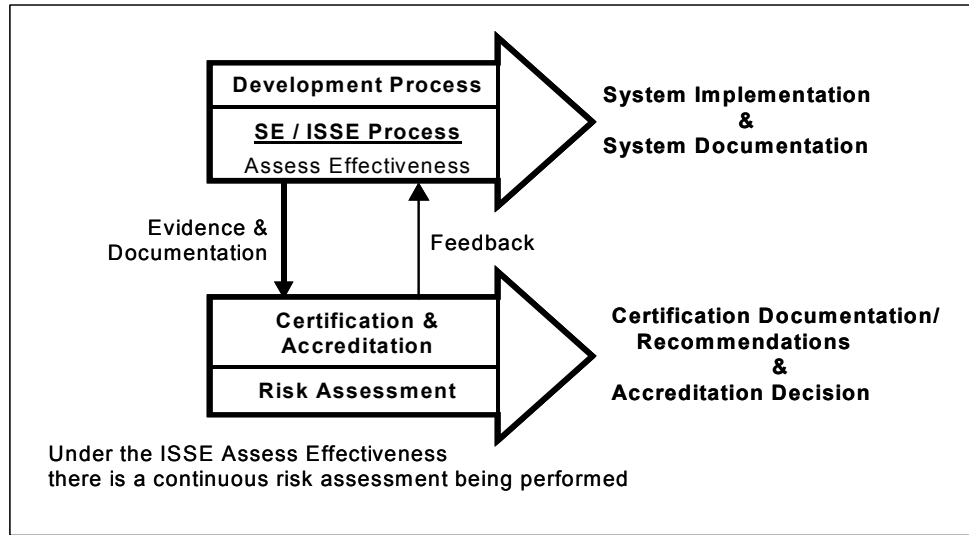

iatf\_3\_7\_3007

**Figure 3-7. Relationship of SE/ISSE and C&A**

DITSCAP is not a design process. It does not provide information on how to discover requirements or how to design, implement, or evaluate a system. It establishes only what evidence must be collected for an evaluation and that an evaluation must be performed.

In a system development effort in which SE/ISSE was not applied, the evidence and documentation required for C&A may not be available. The certification team may have to retroactively generate this information when they initiate certification efforts after some or all of the development effort is complete. There are four phases in the DITSCAP: Definition, Verification, Validation, and Post-Accreditation.

Phase 1, Definition, documents the information protection requirements, the system's context, and the system architecture. The resulting documents are collected and evaluated for completeness. This phase also identifies the level of effort required to achieve accreditation, the Certification Authority (Certifier), and the DAA. The three activities in the Definition phase are preparation, registration, and negotiation. In the preparation activity, information and documentation about the system are collected and reviewed. The types of information collected may include the following:

- Business case.
- MNS.
- System specifications.
- Architecture and design documents.
- User manuals.
- Operating procedures.
- Network diagrams.
- Configuration management documents.
- Threat analysis.



## UNCLASSIFIED

The Information Systems Security Engineering Process  
IATF Release 3.1—September 2002

Typically, this information can be found in system specifications, and the architecture and design documentation generated by the SE/ISSE process in system development.

In the registration activity, the information collected during preparation is evaluated and documented in the SSAA. The tasks that must be performed <sup>2</sup> during registration are as follows:

- Prepare business or operational functional description and system identification.
- Inform the DAA, the Certifier, and the user's representative that the system will require C&A support (register the system).
- Prepare the environment and threat description.
- Prepare system architecture description and describe the C&A boundary.
- Determine system security requirements.
- Tailor the DITSCAP tasks, determine the C&A level of effort, and prepare a DITSCAP plan.
- Identify organizations that will be involved in the C&A and identify the resources required.
- Develop the draft SSAA.

In the negotiation activity, agreement is reached between the program manager, the DAA, the Certifier, and the user's representative on the approach, security requirements, level of effort required for the C&A activities, and schedule. The tasks that must be performed during negotiation are—

- Conduct the certification requirements review.
- Agree on the security requirements, level of effort, and schedule.
- Approve final Phase 1 SSAA.

The ISSE process is the source of many of the documents required in Phase 1, Definition, among them—

- The IPP, written during Discover Information Protection Needs, provides the mission information threat analysis, the information protection requirements needed to counter the identified threats, and the customer's prioritization of the requirements. In addition, the IPP documents who the Certifier and the DAA for the system are.
- The security context, generated during Define System Security Requirements, sets the system boundary and identifies external interfaces to the system.
- The security architecture, developed during Design System Security Architecture.

---

<sup>2</sup> The system engineer, information systems security engineer, or developer, under the direction of the program manager, most often performs these tasks. The certifier is responsible for the content of the SSAA. The DAA approves the SSAA.

## UNCLASSIFIED

The Information Systems Security Engineering Process  
IATF Release 3.1—September 2002

In Phase 2, Verification, documents are collected on the system as designed and implemented. These documents are used to evaluate system compliance with the security requirements and constraints identified in the SSAA. The following tasks must be performed<sup>3</sup> during Verification:

- System architecture analysis.
- Software design analysis.
- Network connection rule compliance analysis.
- Integrity analysis of integrated products.
- Life-cycle management analysis.
- Preparation of security requirements validation procedures.
- Vulnerability assessment.

The output of the ISSE Design System Security Architecture, Develop Detailed Security Design, Implement System Security, and Assess Information Protection Effectiveness activities are the source of many of the documents and much of the analysis required in Phase 2. For example—

- Doctrine from the security architecture in Design System Security Architecture.
- The security design developed in Develop Detailed Security Design.
- The security design analysis from Develop Detailed Security Design
  - Hardware
  - Software
  - Firmware.
- The security configuration from Develop Detailed Security Design.
- Implementation documentation from Implement System Security (e.g., security integration test plans).

Phase 3, Validation, ensures that the implemented design operates in a specific operating environment with an acceptable level of risk. The activities in this phase begin with system integration and end with accreditation of the system. The following are the tasks that, if required,<sup>4</sup> are performed<sup>5</sup> during Validation:

- Security Test and Evaluation (ST&E).
- Penetration testing.
- TEMPEST and Red-Black evaluation.
- COMSEC compliance evaluation.
- System management analysis.
- Site accreditation survey.
- Contingency plan evaluation.
- Risk management review.

---

<sup>3</sup> Certifiers and evaluators most often perform these tasks. SE and ISSE support these tasks.

<sup>4</sup> As an example, TEMPEST may not be a requirement if the system is within the continental United States.

<sup>5</sup> Certifiers and evaluators most often perform these tasks with SE and ISSE support.

## UNCLASSIFIED

The Information Systems Security Engineering Process  
IATF Release 3.1—September 2002

The output of the ISSE activities Develop Detailed Security Design, Implement System Security and Assess Information Protection Effectiveness are the source of much of the input that is required in Phase 3. For example—

- During the Develop Detailed Security Design activity, the information systems security engineer either writes or provides input to detailed security test plans, such as an ST&E. During Implement System Security, the information systems security engineer supports and analyzes the results of those tests.
- During Implement System Security and Assess Information Protection Effectiveness, the information systems security engineer provides support to any ongoing risk management activities.

Phase 4, Post-Accreditation, contains the activities required to continue to operate and manage the system so that it will maintain an acceptable level of risk. Phase 4 begins once the system has been accredited. With any major changes to the system, DITSCAP reverts to Phase 1. The tasks performed under Phase 4 are as follows:

- SSAA maintenance.
- Physical, personnel, and management control review.
- TEMPEST evaluation.
- COMSEC compliance evaluation.
- Contingency plan maintenance.
- Configuration management.
- System security management.
- Risk management review.

If DITSCAP reverts to Phase 1, the support from ISSE is provided as described in the previous paragraphs.

## 3.6 Summary

This chapter provides an overview of the ISSE process followed by discussion of four main topics: SE and ISSE principles, the ISSE process, a correlation between sample SE processes and the ISSE process, and the relationship of the ISSE process to DITSCAP.

The three SE and ISSE principles are—

1. Always keep the problem and the solution spaces separate.
2. The problem space is defined by the customer's mission or business needs.
3. The systems engineer and information systems security engineer define the solution space, driven by the problem space.

The summary of these principles emphasizes that the customer owns the problem—it is the customer's mission or business that the system is intended to support. Though the customer

owns the problem, the customer is not always the expert in discovering and documenting it, and here the systems engineer or information systems security engineer should help. The systems engineer and the information systems security engineer and not the customer are the experts in developing solutions. The systems engineer and the information systems security engineer should resist the customer's tendency to intervene in the design of the system. Customer design inputs could become constraints on the final design and limit the SE design flexibility.

The ISSE process section covers six activities that correspond to a generic SE process:

- Discover Information Protection Needs (Discover Needs).
- Define System Security Requirements (Define System Requirements).
- Design System Security Architecture (Design System Architecture).
- Develop Detailed Security Design (Develop Detailed Design).
- Implement System Security (Implement System).
- Assess Information Protection Effectiveness (Assess Effectiveness).

Each activity stresses the importance of interaction with the customer. The National Cryptologic School (NCS) offers courses on the SE/ISSE process:

- IAEC3186 *Introduction to ISSE*.
- IAEC3341 *Protection Needs Elicitation*.

The third topic in this chapter shows the similarities between the ISSE process and two standard SE processes, DoD 5000.2-R, Mandatory Procedures for Major Defense Acquisition Programs (MDAP) and Major Automated Information System (MAIS) Acquisition Programs, and the IEEE Standard for Application and Management of the Systems Engineering Process.

The relationship between the ISSE process and DITSCAP is best summarized in Figure 3-7. The figure shows that the development (SE/ISSE) process and the C&A process are separate. The SE/ISSE process results in system implementation and system documentation. The C&A process results in certification documentation, a certification recommendation, and an accreditation decision. The SE/ISSE process produces evidence and documentation used by the C&A process. The C&A process provides feedback used by the SE/ISSE process. This section also points out that DITSCAP is a C&A process and not a design process.

## UNCLASSIFIED

The Information Systems Security Engineering Process  
IATF Release 3.1—September 2002

### References

1. IAEC3341. Protection Needs Elicitation (PNE), Session 01-02, October 2001.
2. DoD 5000.2-R, Mandatory Procedures for Major Defense Acquisition Programs (MDAPs), and Major Automated Information System Acquisition Programs (MAIS).
3. DoD Directive 5200.40, DoD Information Technology Security Certification and Accreditation Process (DITSCAP), 30 November 1997.
4. IAEC3186. Introduction to Information Systems Security Engineering (ISSE), Session 02-01, September 2001.
5. IEEE Standard for Application and Management of the Systems Engineering Process (IEEE Std 1220-1998).

# Chapter 4

## Technical Security Countermeasures

---

The authors of the Information Assurance Technical Framework (IATF) recognize the importance of using both technical and nontechnical countermeasures in formulating an effective overall security solution to address attacks at all layers of the information infrastructure. This chapter of the IATF discusses principles for determining appropriate technical security countermeasures. It includes information on attacks, important security services, robustness strategy, the interoperability framework, and the Key Management Infrastructure (KMI)/Public Key Infrastructure (PKI). It also provides background for the detailed technical discussions contained in later sections of the IATF.

### 4.1 Introduction

Adversaries' primary goals fall into three general categories: unauthorized access, unauthorized modification, and denial of authorized access. Security solutions are implemented to prevent an adversary from successfully achieving these goals. This chapter discusses attacks, security services, and appropriate security technologies. By using the methodology described in Chapter 3, Information Systems Security Engineering Process, in conjunction with consideration of applicable attacks, security solutions can be proposed that support appropriate security services and objectives. Subsequently, proposed security solutions may be evaluated to determine if residual vulnerabilities exist, and a managed approach to mitigating risks may be proposed.

“Security services” are services that safeguard and secure information and information systems. Access control, confidentiality, integrity, availability, and nonrepudiation are the five primary areas of security service. These services are provided by incorporating security mechanisms, e.g., encryption, identification, authentication, access control, security management, and trust technology, into the information system to form a barrier to attack. This chapter presents an overview of each service, a breakdown of its various elements, and a detailed look at the security mechanisms that support it.

Three additional topics, robustness, interoperability, and KMI/PKI, should be considered in selecting security countermeasures. The robustness strategy provides the philosophy behind, and initial guidance for, selection of the strength of security mechanisms and the security assurance provisions that may be needed for a particular value of information and a potential threat level. This section defines the IATF strategy for measuring and assessing the need for various levels of robustness for technical, and selected nontechnical, security countermeasures. The robustness strategy is not intended to provide universal answers on needed strength or assurance, that is, it is not a “cookbook.” The final selection of mechanisms, and the decision on the level of strength and assurance needed will be based on an Information Systems Security Engineering (ISSE) activity that addresses the situation of a specific user, mission, and environment.

The robustness of a security solution must be considered in relation to the system requirement for connectivity. Recognizing the growing need for connectivity, an interoperability framework provides a strategy for ensuring that security provisions (1) do not inhibit the connectivity that is otherwise available and (2) if necessary, maintain backward compatibility with existing system capabilities. The chapter continues with a discussion of KMI/PKI Considerations. It is important to consider the needs that a KMI/PKI creates and the demands it places on network users and operators in any potential network security solution.

This chapter provides a framework for considering these topics. Each aspect of the solutions addressed in this chapter should be considered in relation to the other aspects. For example, the robustness of a solution depends on the way the technology is implemented. Similarly, knowledge of the primary security services and the important security technologies will facilitate formation of effective security solutions. In addition, considering interoperability and KMI/PKI during the formulation of a security solution will help ensure the effectiveness of that solution.

## **4.2 Adversaries, Motivations, and Categories of Attacks**

Adversaries come from various backgrounds and have a wide range of financial resources at their disposal. In this section a host of potential adversaries are examined, as are the questions. What produces an adversary? What are each adversary's motivations? What categories of attacks do the different types of each adversaries use? In addition to providing information on the various potential adversaries, this section provides examples of various types of the different categories providing a brief description of how each attack is performed and by whom.

This section also discusses the countermeasures that can be used against potential adversaries and different categories of attack.

### **4.2.1 Potential Adversaries**

Typically adversaries are thought of as having malicious intent. However, in the context of system and information security and protection, it is also important to consider the threat posed by those without malicious intent. Table 4-1 shows examples of individuals and organizations in both of these categories.

**Table 4-1. Potential Adversaries**

Adversary	Description
<b>Malicious</b>	
Nation States	Well-organized and financed. Use foreign service agents to gather classified or critical information from countries viewed as hostile or as having economic, military, or political advantage.
Hackers	A group or individuals (e.g., hackers, phreakers, crackers, trashers, and pirates) who attack networks and systems seeking to exploit the vulnerabilities in operating systems or other flaws.
Terrorists/ Cyberterrorists	Individuals or groups operating domestically or internationally who represent various terrorist or extremist groups that use violence or the threat of violence to incite fear with the intention of coercing or intimidating governments or societies into succumbing to their demands.
Organized Crime	Coordinated criminal activities, including gambling, racketeering, narcotics trafficking, and many others. An organized and well-financed criminal organization.
Other Criminal Elements	Another facet of the criminal community, but one that is normally not very well organized or financed. Usually consists of very few individuals or of one individual acting alone.
International Press	Organizations that gather and distribute news, at times illegally, selling their services to both print and entertainment media. Involved in gathering information on everything and anyone at any given time.
Industrial Competitors	Foreign and domestic corporations operating in a competitive market and often engaged in the illegal gathering of information from competitors or foreign governments through corporate espionage.
Disgruntled Employees	Angry, dissatisfied individuals who can inflict harm on the local network or system. Can represent an insider threat depending on the current state of the individual's employment and access to the system.
<b>Nonmalicious</b>	
Careless or Poorly Trained Employees	Users who, through lack of training, lack of concern, or lack of attentiveness, pose a threat to information and information systems. This is another example of an insider threat or adversary.

### 4.2.1.1 Motivations

Individual motivations to “get inside” are many and varied. Persons with malicious intent who wish to achieve commercial, military, or personal gain are known as hackers [1]. At the opposite end of the spectrum are persons who compromise the network accidentally. Hackers range from the inexperienced professional, college student, or novice (e.g., Script Kiddy) to the highly technical and very capable (e.g., Uberhacker). Most hackers pride themselves on their skill and seek, not to destroy, but simply to gain access so that the computer or network can be used for later experimentation. Hackers often believe that by exposing a hole or “back-door” in a computer system, they are actually helping the organization to close the holes, providing a benefit to the Internet and a needed resource. Other hackers have less benign motives for getting inside.



## UNCLASSIFIED

Technical Security Countermeasures  
IATF Release 3.1—September 2002

Intelligence gathering, information operations, and psychological warfare are some motivations behind attempts to gain access. The following are some common reasons why an adversary might want to exploit a particular target:

- Gain access to classified or sensitive information. (Note: What is of high value to one person or organization might be of no value to another.)
- Track or monitor the target's operations (traffic analysis).
- Disrupt the target's operations.
- Steal money, products, or services.
- Obtain free use of resources (e.g., computing resources or free use of networks).
- Embarrass the target.
- Overcome the technical challenge of defeating security mechanisms.

From an information system standpoint, these motivations can express themselves in three basic goals: access to information, modification or destruction of information or system processes, or denial of access to information. In attacking an information processing system, an adversary accepts a certain amount of risk. This risk may be time dependent. The risk of loss to the adversary may far exceed the expected gain. Risk factors include—

- Revealing the adversary's ability to perform other types of attacks.
- Triggering responses that might prevent the success of a future attack, especially when the gain is much greater.
- Incurring penalties (e.g., fines, imprisonment, embarrassment).
- Endangering human life.

The level of risk that an adversary is willing to accept depends on the adversary's motivation.

### 4.2.2 Classes of Attack

Chapter 1, Introduction, Table 1-1, Classes of Attack, defines the five categories of system attack. Figure 4-1 shows each class of attack in relation to the information infrastructure. Each attack has unique characteristics that should be considered in defining and implementing countermeasures. This section provides an overview of each class of attack, with specific examples of attacks for each class. Several classes of network-based attacks are considered in the following discussion.

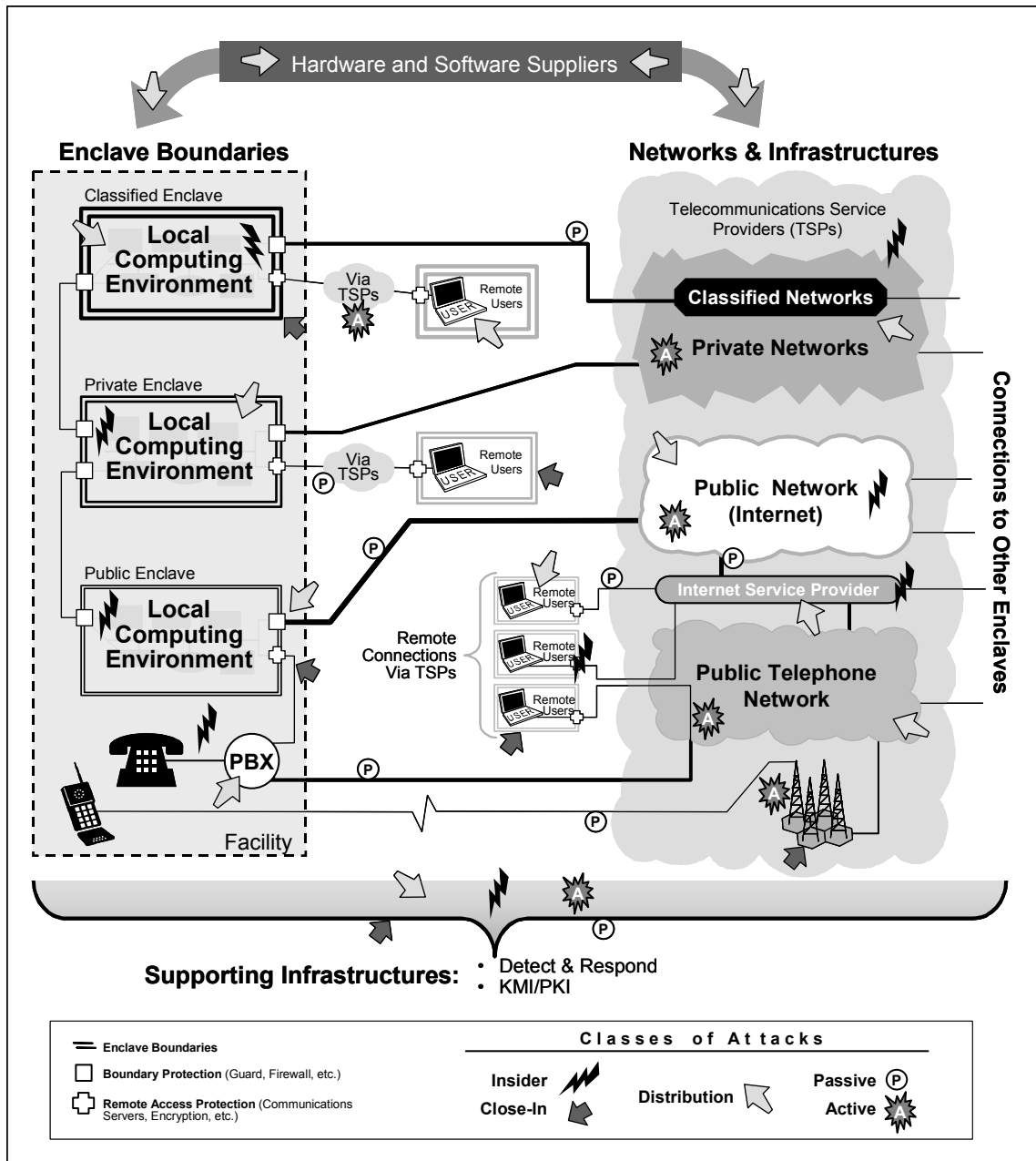

iattf\_4\_1\_4000

Figure 4-1. Categories of Attacks Against Networked Systems

### 4.2.2.1 Passive Attacks

These attacks involve passive monitoring of communications sent over public media (e.g., radio, satellite, microwave, and public switched networks). Countermeasures used against passive attacks include virtual private networks (VPN), cryptographically protected networks, and protected distribution networks (e.g., physically protected or alarmed wireline distribution network). Table 4-2 provides examples of attacks characteristic of this class.

**Table 4-2. Examples of Passive Attacks**

<b>Attack</b>	<b>Description</b>
Monitoring Plaintext	An attacker monitoring the network could capture user or enclave data that is not otherwise protected from disclosure.
Decrypting Weakly Encrypted Traffic	Cryptoanalytic capability is available in the public domain, as witnessed by the June 1997 collaborative breaking of the 56-bit-strength Data Encryption Standard. While the near-term potential for attack on large volumes of traffic is questionable given the number of machines and hours involved, breaking of DES does show the vulnerability of any single transaction.
Password Sniffing	This type of attack involves use of protocol analyzers to capture passwords for unauthorized reuse.
Traffic Analysis	Observation of external traffic patterns can give critical information to adversaries even without decryption of the underlying information. For example, extension of a network into a tactical theater of operations may indicate the imminence of offensive operations thereby removing the element of surprise.

### 4.2.2.2 Active Attacks

Active attacks include attempts to circumvent or break security features, introduce malicious code (such as computer viruses), and subvert data or system integrity. Typical countermeasures include strong enclave boundary protection (e.g., firewalls and guards), access control based on authenticated identities (ID) for network management interactions, protected remote access, quality security administration, automated virus detection tools, auditing, and intrusion detection. Table 4-3 provides examples of attacks characteristic of this class.

**Table 4-3. Examples of Active Attacks**

<b>Attack</b>	<b>Description</b>
Modifying Data in Transit	In the financial community, it would be disastrous if electronic transactions could be modified to change the amount of the transaction or redirect the transaction to another account.
Replaying (Insertion of Data)	Reinsertion of previous messages could delay timely actions. Bellovin shows how the ability to splice messages together can be used to change information in transit.
Session Hijacking	This attack involves unauthorized use of an established communications session.
Masquerading as Authorized User/Server	This attack involves an attacker's identifying himself or herself as someone else, thereby gaining unauthorized access to resources and information. An attacker first gets user or administrator information by employing sniffers or other means, then uses that information to log in as an authorized user. This class of attack also includes use of rogue servers to obtain sensitive information after establishing what is believed to be a trusted service relationship with the unsuspecting user.

Attack	Description
Exploiting System-Application and Operating System Software	An attacker exploits vulnerabilities in software that runs with system privileges. Well-known attacks involve sendmail and X-Windows server vulnerabilities. Recently, there has been an increase in alerts regarding Windows 95 and Windows NT vulnerabilities. New vulnerabilities for various software and hardware platforms are discovered almost daily. Attacks, vulnerabilities, and patches are reported through the various computer emergency response alerts and bulletins.
Exploiting Host or Network Trust	An attacker exploits transitive trust by manipulating files that facilitate the provision of services on virtual/remote machines. Well-known attacks involve UNIX commands, .rhosts and .rlogin, which facilitate workstation's sharing of files and services across an enterprise network.
Exploiting Data Execution	An attacker can get the user to execute malicious code by including the code in seemingly innocent software or e-mail for downloading. The malicious code might be used to destroy or modify files, especially files that contain privilege parameters or values. Well-known attacks have involved PostScript, Active-X, and MS Word macro viruses.
Inserting and Exploiting Malicious Code (Trojan horse, trap door, virus, worm)	An attacker can gain execution access to a user's system commands through one of the vulnerabilities previously identified and use that access to accomplish his or her objectives. This could include implanting software to be executed based on the occurrence of some future event. Hacker tools are available on the Internet. These tools have turnkey capabilities, including an insertion script, root grabbing, Ethernet sniffing, and track hiding to mask the presence of a hacker.
Exploiting Protocols or Infrastructure Bugs	An attacker exploits weaknesses in protocols to spoof users or reroute traffic. Well-known attacks of this type include spoofing domain name servers to gain unauthorized remote login, and bombing using Internet Control Message Protocol (ICMP) to knock a machine off the air. Other well-known attacks are source routing to impersonate a trusted host source, Transmission Control Protocol (TCP) sequence guessing to gain access, and TCP splicing to hijack a legitimate connection.  Malicious code can exfiltrate information through a lower level tunnel within a VPN. At least one published paper points out potential security concerns revolving around use of Internet Protocol Security default security mechanisms. In addition, Bellovin points out occasions on which the integrity functions of Data Encryption Standard in Cipher Block Chaining mode can be circumvented, with the right applications, by splicing of packets.
Denial of Service	An attacker has many alternatives in this category, including ICMP bombs to effectively get a router off the network, flooding the network with garbage packets, and flooding mail hubs with junk mail.

### 4.2.2.3 Close-In Attacks

Close-in attacks are attacks in which an unauthorized individual gains close physical proximity to networks, systems, or facilities for the purpose of modifying, gathering, or denying access to information. Gaining such proximity is accomplished through surreptitious entry, open access, or both. Table 4-4 provides examples of specific attacks characteristic of this class.

**Table 4-4. Examples of Close-In Attacks**

Attack	Description
Modification of Data/Information Gathering	This results from an individual gaining physical access to the local system and modifying or stealing information, such as, Internet Protocol addresses, login ID schemes, and passwords.
System Tampering	This type of attack results from an individual in close proximity gaining access to and tampering with the system (e.g., bugging, degrading).
Physical Destruction	This type of attack results from an individual in close proximity gaining physical access, and causing the physical destruction of a local system.

## 4.2.2.4 Insider Attacks

Insider attacks are performed by a person who either is authorized to be within the physical boundaries of the information security processing system or has direct access to the information security processing system. There are two types of insider attacks: malicious and nonmalicious (the latter involving carelessness or ignorance of the user). The nonmalicious case is considered an attack because of the security consequences of the user's action.

- **Malicious Insider Attacks.** Federal Bureau of Investigation (FBI) estimates indicate that 80 percent of attacks and intrusions come from within organizations (see <http://www.cs.purdue.edu/coast/intrusion-detection/>) [3]. An insider knows the layout of the system, where the valuable data is, and what security precautions are in place. Insider attacks originate from within the enclave and are often the most difficult to detect and to defend against.

Sources of insider attacks can include uncleared cleaning crews (with after-hours physical access), authorized (privileged to login) system users, and system administrators with malicious intent. Often it is difficult to prevent individuals who have legitimate access to a system from accessing into more private areas to which they do not have authorized access. Insider attacks may focus on compromise of data or access and can include modification of system protection measures. A malicious insider may use covert channels to signal private information outside of an otherwise protected network. However, there are many other avenues by which a malicious insider can damage an information system.

- **Nonmalicious Insider Attacks.** These attacks are caused by authorized persons who have no intent to cause damage to the information or to the information processing system but may unintentionally do so. The damage in this case is caused by lack of knowledge or by carelessness.

Typical countermeasures include security awareness and training; auditing and intrusion detection; security policy and enforcement; specialized access control for critical data, servers, local area networks (LAN), etc., implemented by trust technology in computer and network

elements; and a strong identification and authentication (I&A) capability. Table 4-5 contains examples of attacks characteristic of this class.

**Table 4-5. Examples of Insider Attacks**

<b>Attack</b>	<b>Description</b>
<b>Malicious</b>	
Modification of Data or Security Mechanisms	Insiders often have access to information due to commonality of shared networks. This access can, allow manipulation or destruction of information without authorization.
Establishment of Unauthorized Network Connections	This results when users with physical access to a classified network create an unauthorized connection to a lower classification level or lower sensitivity network. Typically this connection is in direct violation of the classified network's security policy or user directives and procedures.
Covert Channels	Covert channels are unauthorized communication paths used for transferring misappropriated information from the local enclave to a remote site.
Physical Damage/ Destruction	This is intentional damage to, or destruction of, a local system resulting from the physical access afforded the insider.
<b>Nonmalicious</b>	
Modification of Data	This type of attack results when insiders, either through lack of training, lack of concern, or lack of attentiveness, modify or destroy information located on the system.
Physical Damage/ Destruction	This type of attack is listed under malicious as well. As a nonmalicious attack, it can result from carelessness on the part of the insider, for instance, failure to obey posted guidance and regulations, resulting in accidental damage to or destruction of, a system.

### 4.2.2.5 Distribution Attacks

The term “distribution attack” refers to the potential for malicious modification of hardware or software between the time of its production by a developer and its installation, or when it is in transit from one site to another. Vulnerability at the factory can be minimized by strong in-process configuration control. Vulnerability to distribution attacks can be addressed by use of controlled distribution or by signed software and access control that is verified at the final user site. Table 4-6 contains examples of attacks characteristic of this class.

**Table 4-6. Examples of Distribution Attacks**

Attack	Description
Modification of Software/Hardware at Manufacturer's Facility	These attacks can involve modifying of the configuration of software or hardware while it is cycling through the production process. Countermeasures for attacks during this phase include rigid integrity controls, including high-assurance configuration control and cryptographic signatures on tested software products.
Modification of Software/Hardware during Distribution	These attacks can involve modifying of the configuration of software or hardware during its distribution (e.g., embedding of listening devices during shipment). Countermeasures for attacks during this phase include use of tamper detection technologies during packaging, use of authorized couriers and approved carriers, and use of blind-buy techniques.

## 4.3 Primary Security Services

The IATF guidance incorporates five primary security services areas: access control, confidentiality, integrity, availability, and nonrepudiation. The division of network security principles into standard security service categories is convenient for this description. The categories presented below roughly coincide with the “basic security services” identified in the 1990 Recommendation X.800, “Security Architecture for Open Systems Interconnection for Consultative Committee for International Telephone and Telegraph (CCITT) Applications” (which is technically aligned with International Organization for Standardization [ISO] 7498-2, “Information Processing Systems Open Systems Interconnection, Basic Reference Model,” Part 2: Security Architecture), and more recently, the ISO/International Engineering Consortium (IEC) 10181 series, Parts 1-7.

In practice, none of these security services is isolated from or independent of the other services. Each service interacts with and depends on the others. For example, access control is of limited value unless preceded by some type of authorization process. One cannot protect a system or information from unauthorized entities if one cannot determine whether that entity one is communicating with is authorized. In actual implementations, lines between the security services also are blurred by the use of mechanisms that support more than one service.

Given these caveats, this section characterizes each service according to its basic functional elements and discusses the mechanisms that are available to implement the elements of that service. Where appropriate, considerations of the relative strengths of these mechanisms are also noted.

### 4.3.1 Access Control

In the context of network security, access control means limiting access to networked resources (hardware and software) and data (stored and communicated). The goal of access control is to

prevent the unauthorized use of these resources and the unauthorized disclosure or modification of data. Access control also includes resource control, for example, preventing logon to local workstation equipment or limiting use of dial-in modems. For the purposes of this discussion, network access control is not concerned with denying physical access (e.g., via locked rooms or tamperproof equipment).

Access control is applied to an entity based on an identity or an authorization. An identity may represent an actual user, a process with its own identity (e.g., a program making a remote access connection), or a number of users represented by single identity (e.g., role-based access control).

Access control mechanisms are most often used as a set of mechanisms, which may be used by other security services. Confidentiality, integrity, availability, and limiting use of network resources all depend on limiting the ability of an adversary to access an item or service.

The elements of access control can be categorized as follows:

- **I&A.** Establishing the identities of entities with some level of assurance (an authenticated identity).
- **Authorization.** Determining the access rights of an entity, also with some level of assurance.
- **Decision.** Comparing the rights (authorization) of an authenticated identity with the characteristics of a requested action to determine whether the request should be granted.
- **Enforcement.** Enforcement may involve a single decision to grant or deny or may entail periodic or continuous enforcement functions (continuous authentication).

The following subsections discuss these elements and provide examples of the mechanisms that are available to implement them.

### 4.3.1.1 I&A

I&A is a set of security services used in conjunction with most other security services. The first step of most security services is to determine the identities of one or more of the parties participating in an action. A trusted identity must be used for access control decisions and to provide nonrepudiation and accountability evidence. Knowing the identity of an entity and the existence of a peer relationship is also fundamental to establishing communication with confidentiality and integrity. If the identity of the peer in a secure communications path is not properly established, it leaves open the possibility that an unauthorized user (an adversary) could masquerade as an authorized user, exposing the data to disclosure or manipulation.

The process of determining an authentic identity is presented in the following subsections.



### 4.3.1.1.1 Assigning, Binding, and Representing

There must be a mechanism for providing some assurance in the assignment of an identity. The entity that assigns the ID must have a position with some level of trust (either implied or assured by a third entity common to both with a higher position or level of trust). These trusted entities must implement a process of identity-checking that protects against assignment of improper IDs. Examples include checking driver's licenses or verifying fingerprints. Assigning an ID is the equivalent of a registration process and can take place through an existing security mechanism with its own identity establishment mechanism.

An identity must be unique within the community that will be validating that identity. This requires implementation of a community wide authentication mechanism that provides a unique ID to each entity. The community needs to implement an authentication mechanism that provides for a unique identity for each entity. All potential entities must recognize and process an identity in this mechanism. This implies the mechanism must employ a standard format for representing identity.

Identities used for network access control can be assigned and represented by many different mechanisms:

- System administrators providing accounts and passwords for UNIX user names.
- Network administrators assigning Internet Protocol (IP) addresses to machines.
- Key distribution methods that distribute symmetric keys.
- Key distribution methods that distribute public/private key pairs.
- Certification authorities (CA) generating public key certificates containing distinguished names (DN).
- Security officers associating a set of fingerprints with a common name.

The assurance level attributed to an ID depends on the processes used to verify the correctness of that identity before it is issued, the trust instilled by the entity assigning the identity, and the strength of the binding between the entity and the identity. Verification may range from requesting a mother's maiden name over the telephone to checking driver's licenses or verifying fingerprints in person. Means of instilling trust in issuers include procedural mechanisms, such as a company's assigning system administrators; legal mechanisms, such as notaries; and technological mechanisms, such as certification paths in a certification hierarchy. Mechanisms for binding entities to IDs include signed X.509 certificates and password files associated with access control lists (ACL).

Strongly establishing identities for communicating entities is the first step in countering any attack that is predicated on adversaries representing themselves as someone or something that they are not (including masquerading and insider modification attacks).

### 4.3.1.1.2 Communicating and Authenticating

To authenticate an entity that is attempting to gain access, an identity must be associated with the access request and provided to the communicating peer. Along with an indication of identity, the authenticating peer must have the parameters (authentication information) needed to validate that identity. Authentication is implemented by user-to-host and peer-to-peer, and trusted third party (TTP) architectures as follows.

- **User-to-Host:** When a user logs onto a host (or workstation), the user must be identified and authenticated before access to the host or network is granted. This process requires a mechanism to authenticate a real person to a machine. The best methods of doing this involve multiple forms of authentication, such as password, physical token, and biometric verification (i.e., something you *know*, something you *have*, something you *are*).
- **Peer-to-Peer Authentication:** A peer-to-peer authentication architecture, sometimes referred to as mutual authentication protocol, involves the direct communication of authentication information between the communicating entities (e.g., peer-to-peer or client host-to-server). No other entities are required. This architecture is possible only if each entity in a security domain is able to obtain the authentication information of every communicating entity in the domain.
- **Trusted Third Party Authentication:** The architecture for TTP authentication uses a third entity, trusted by all entities, to provide authentication information. A TTP may provide authentication information in each instance of authentication, in real-time, or as a precursor to an exchange (such as a CA). The amount of trust given the third party must be evaluated. Methods of establishing and maintaining a level of trust in a TTP include certification practice statements that establish rules, processes, and procedures that a CA uses to ensure the integrity of the authentication process and use of secure protocols to interface with authentication servers.

The mechanisms used for authenticating an identity can be categorized as simple or cryptographically based. Simple mechanisms may include identification based on IDs that are verified by asking the entity to communicate information that only the entity attempting access would know (e.g., a password and locally stored password file). Assurance comes from the local binding between the password and an identity. Another example of a simple authentication method is address-based authentication. Address-based mechanisms authenticate an identity based solely on assigned network addresses (e.g., IP address) of communicating peers. The system compares the IP address assignment of entities to determine the identity of the communicating entity.

Cryptographically based mechanisms rely on the cryptographic processing of data within a defined protocol. Peers may share a common secret key (often stored in a hardware token) to process, or encrypt the exchange, in a challenge-response protocol. Other cryptographic mechanisms rely on public key cryptography alone, or on the binding between a public key and an identity provided by public key certificates. Examples of how an identity is authenticated in each cryptographic technique are provided below.

## UNCLASSIFIED

Technical Security Countermeasures  
IATF Release 3.1—September 2002

- **Identity Is a Locally Defined Name:** Identities of all potential communicating peers are stored locally in a trusted database that associates identities with their public keys. These public keys correspond to the private key used to sign a unique piece of data. Verifying a signature by using a stored public key authenticates an identity.
- **Identity Is the Defined Name.** From the valid X.509 certificate containing the public key that corresponds to the private key used to sign a unique piece of data. A valid X.509 certificate means that the complete certification path has been validated (including certificate revocation list (CRL) and compromised key list (CKL) checks and validity periods for all certificates) to a trusted root. X.509 certificates (of communicating peers or of the entities in certification paths) may be stored locally (cached), carried in the security association protocol, accessed as needed from an X.500 directory, or any combination of these three methods. Verifying a signature by using a valid public key authenticates an identity.

For all cryptographically based mechanisms, the strength of the mechanism lies partly in the strength of the cryptographic algorithms (including key size), partly in the security of any communications protocol, and in large part, in the protection provided to secret key material.

There are a number of mechanisms for implementing and distributing identity and authentication information. Some of these mechanisms are as follows:

- Names and passwords stored in a database local to the entity making the access control decision.
- IP addresses provided by a secure domain name server (DNS).
- Passwords generated locally based on time (one-time passwords).
- Symmetric keys stored in a local database.
- Public keys stored in a local database.
- Public key certificates provided by directories in response to queries.
- Authentication information carried in the communications protocols themselves.

The assurance level of the communication of identity and authentication information processes depends on whether that information needs protecting and how well it is protected. For example, passwords are sensitive because they can be used by anyone who knows them; they should therefore be encrypted for storage and transport. Certificates can be stored in unprotected directories or carried on unencrypted communications channels because they can only be used by the entity that holds the associated private key.

Note that identity information and the information used to authenticate that identity do not have to flow over the same communications path. A common example is name and password logins. Users are queried for a name and an associated password (the identity information) over the communications protocol. The authenticity of that name and password pair is established only

by checking a locally stored database (the information used to authenticate is provided by an off-line process).

There are entire infrastructures devoted to providing identities and the means of authenticating those identities. Examples of infrastructures supporting the determination of an authentic identity include the X.509 authentication framework, the Internet Engineering Task Force (IETF) PKI, the secure DNS initiatives, and the Simple Public Key Infrastructure (SPKI).

### **4.3.1.2 Authorization**

Another important step in an access decision is determining the authorizations of one or more of the parties participating in a communication. These authorizations result in the granting of a set of privileges to an entity. Much like IDs, authorizations must be conveyed in a commonly understood format and must be presented or maintained with some level of confidence. The process of determining an authenticated set of authorizations generally consists of the same components as that for determining an authenticated identity. A strong mechanism for determining authorizations can prevent an attack in which an entity attempts to forge access rights.

The process of determining the authorizations of an entity consists of assigning authorizations, binding authorizations to an entity, representing those authorizations in a standard format, communicating those authorizations, and establishing the authenticity of the authorizations. These steps are discussed below.

#### **4.3.1.2.1 Assigning, Binding, and Representing**

As in assigning identity, the process that determines and assigns authorizations must evoke a level of trust. Responsibility for that process falls on roles such as CA, attribute authority, ACL administrator, and system administrator. Authorizations used for network access control can be assigned by—

- System administrators, who assign user names to groups.
- Data owners, who grant authorizations to read/write/execute files.
- Network administrators, who generate ACLs.
- X.500 CAs, who generate version 3 X.509 certificates containing extensions.
- Attribute authorities, who generate American National Standards Institute (ANSI) X9.57 attribute certificates.

#### **4.3.1.2.2 Communicating and Authenticating**

Communicating authorization information follows the same model as authentication information. The information may be pre-distributed and stored at each entity (e.g., ACL); it may be carried in the communications protocol; or it may be provided by a TTP (e.g., X.500 directory, Radius authentication servers). There are a number of models for distributing authorization information:

## UNCLASSIFIED

Technical Security Countermeasures  
IATF Release 3.1—September 2002

- ACLs stored local to the entity making the access control decision.
- X.500 directories deployed to provide X.509 certificates.
- X.500 directories deployed to provide attribute certificates.

Authenticity of authorization information is provided either by its trusted relationship with identity information (local binding) or because it is carried in cryptographically verifiable certificates.

The level of trust attributed to the third parties used for obtaining authorization information (either the parties who generated the authorizations initially or those that distribute them when needed) is always an issue. The cryptographic techniques invoked to prove the authenticity of X.509 certificates and to bind attribute certificates to identity certificates represent one attempt to ensure that trust.

### 4.3.1.3 Decision

The components discussed previously provide the information required to make an access control decision. They provide mechanisms for determining both the identity and the privilege set of a communicating entity. In practice, access decisions are usually based on an access control policy, commonly referred to in the classified arena as discretionary or mandatory policies. International standards do not use the “mandatory/discretionary” terminology, but instead use the terms Identity Based Access Control (IBAC), which bases decisions on an identity, or Rule-Based Access Control (RBAC), which checks an entity’s authorizations against an established rule set. Within the scope of this discussion, IBAC and discretionary policies can be considered equivalent, and RBAC and mandatory policies can be considered equivalent. In either case, the function of an access control decision is to grant or deny requests for access.

An IBAC decision grants or denies a request based on the presence of an entity on an ACL. If an entity is on the ACL, access to the requested information or resource is permitted; otherwise, access is denied. IBAC requires an authenticated identity before granting any access.

An RBAC decision depends on policies that can be algorithmically expressed and thus implemented on a computer system. These policies are stated in a way that requires resources to have restrictions and entities to have authorizations. Access to a resource is granted on the basis of an entity’s authorizations rather than an entity’s identity. An RBAC decision requires authorization information and restriction information to compare before any access is granted.

A composite policy, referred to as role-based policy, can be considered a variant of both IBAC and RBAC. In this case, an identity is assigned to a group that has been granted authorizations. Identities can be members of one or more groups. A current example is the Global Command and Control System (GCCS), which depends on organizational and role associations.

Most network operating systems have their own method of implementing access control, but they are all identity-based IBAC. Entities are granted access to resources based on an identity established during network logon, which is compared with one or more ACLs. These lists may

be individually administered, may be centrally administered and distributed to individual locations, or may reside on one or more central servers.

Mechanisms for establishing identities and authorizations have been discussed in previous sections. Mechanisms for establishing restrictions on access to a resource must be provided to implement an RBAC scheme. Since rule-based access controls how rules are implemented primarily in systems dealing with sensitive information, restrictions are most often expressed as policies for accessing sensitive data. To facilitate these policies, the sensitivities of a data item are conveyed in a data label and must be compared with the set of privileges assigned to an entity. Access is granted to sensitive information if an entity's privileges are appropriate for the sensitivities of the data. An example of a rule-based policy is the classifications used to distinguish information on a national security level, such as top secret, secret, and confidential, and the rule that identities authorization for any security level as also authorizing access to all lower security levels. Users who hold secret clearances will be allowed to access secret and below classified information.

Consistent with the issues surrounding identities and authorizations, data labels must also be assigned, bound, represented, communicated, and authenticated. There are currently many representations of a data security label (Federal Information Publications [FIPS] [4] 188 Standard Security Label, Secure Data Exchange (SDE) Security Label—Institute for Electrical and Electronic Engineers (IEEE) 802.10g, Internet Security Label, ISO SC-27 Security Label, Common Security Label [Military Standard (MIL STD) 2045-48501], X.411 Message Handling System (MHS): Message Transfer System (MTS) Service Definition—Security Label). Establishment of a universally accepted standard is an area for further work.

Note that an access request can actually be composed of a complicated set of parameters. For example, a particular access might be, "Execute a file labeled top secret at 3:15 p.m. during a time of war." Defining "access" in this manner allows the access decision function to provide a binary grant or deny result. This introduces a new set of information that must be represented, communicated, and authenticated, including contextual information, such as time, status, or current conditions.

### **4.3.1.4 Enforcement**

Actual enforcement of the access control decision is the step that actually provides protection against attacks. All previously discussed mechanisms for preventing attacks come together here with the enforcement of those protections.

The concept of enforcing an access control decision is separate from the decision itself. This is because the two processes may reside in different places architecturally. This separation permits the concept of an "authentication server" that makes an access decision for the network communications process to allow or prevent a requested access from taking place. For example, the access decision may result in the subject's being provided with a token (such as a certificate) that guarantees the subject the right to access its target up to, but no more than,  $n$  times before a

given time. This token is called a ticket or capability. These tokens may be cached at the target to improve efficiency.

An access control decision and its enforcement can be made at either end of a communications association. An example is the difference between a client's accessing a File Transfer Protocol (FTP) server (the server limits access to files after a client request is submitted) and an e-mail message (in which the originator decides whether the recipient should receive the message before a connection is made). In the e-mail example, the recipient's mail software may also perform an additional access control check to determine whether the recipient can be allowed to view the message.

Another distinction between access control mechanisms is whether the decision and enforcement process occurs once at the initiation of a communications session, is repeated periodically throughout a session, or qualifies as "continuously authenticated." A method commonly used to ensure that access to a communications session is controlled continuously is use of encryption mechanisms to prevent loss of control of the session (session stealing or hijacking). Indeed, it can be argued that access is not completely controlled if information flowing over a public network is not protected by the confidentiality security service.

Enforcement of an access control decision may take place at many places in a network's architecture. Access controls may be enforced at network boundaries (e.g., firewalls, routers, and dial-in communications servers), at application servers, or anyplace in the protocol stack or operating system of individual workstations. An important implementation option is inclusion of access control mechanisms at many layers throughout a network architecture.

## 4.3.2 Confidentiality

The confidentiality security service is defined as preventing unauthorized disclosure of data (both stored and communicated). This definition is similar to, and actually a subset of, the description of access control in Section 4.3.1. In fact, it can be argued that providing access control also provides confidentiality, or conversely, that providing confidentiality is a type of access control. We include in the definition of "information," data that is not traditional user data (examples are network management data, routing tables, password files, and IP addresses on data packets). Confidentiality services will prevent disclosure of data in storage, transiting a local network, or flowing over a public Internet. One subset of confidentiality is "anonymity," a service that prevents disclosure of information that leads to the identification of the end user.

The provision of the confidentiality security service depends on a number of variables:

- **Location(s) of the Data that Needs Protection.** Data can exist on an individual machine (e.g., on a hard disk in an end system or in a file on a server), on the wires of a local network, in transport via other mechanisms (e.g., floppy disk), or flowing across a totally public medium (e.g., across the Internet or via a satellite).

- **Type of Data that Needs Protection.** Data elements may be local files (e.g., passwords or secret keys), data carried in a network protocol, or the exchanges of a network protocol (e.g., a protocol data unit).
- **Amounts or Parts of User Data that Need Protection.** It may be necessary to protect an entire data element, only parts of a data element or protocol data unit, or the existence of an entire set of protocol exchanges.
- **Value of Data that Needs Protection.** The sensitivity and perishability of the data being protected influence the provision of security services, particularly the strength of mechanisms implemented. The value of the data to the owner in assessing the threats to information.

The elements of confidentiality are as follows:

- **Data Protection.** This is prevention of disclosure of the contents of data even if it is accessible (e.g., flowing over a network). This element invokes mechanisms that act directly on the data (or act in response to characteristics of the data) rather than acting in response to an entity's attempt to access data.
- **Data Separation.** Data separation traditionally refers to the concept of providing for separate paths (Red/Black or physical) or process separation (computer security [COMPUSEC] techniques, etc.).
- **Traffic Flow Protection.** Data characteristics include frequency, quantity, destination of traffic flow, etc. Traffic flow protection includes not only characteristics but also inference information such as command structure, and even the instance of communication (e.g., a network communication).

### 4.3.2.1 Data Protection

In cases in which communicated data will be visible to possible adversaries (i.e., via passive monitoring attacks), the most common method for providing confidentiality by data protection is to encrypt the appropriate data. Encryption is also used to protect stored data that might be accessed by an adversary (e.g., via the network-based attacks described in Chapter 3, Information Systems Security Methodology).

Encryption is defined as the transformation of data into a form that is unreadable by anyone who does not possess the appropriate secret key. There are many ways of using encryption to provide confidentiality. A small subset includes—

- Security-enabled applications (file encryptors).
- Secure peripherals (media encryptors).
- Operating systems (encrypt local passwords).
- Secure application protocols (secure FTP).
- Security protocols (authentication and key management protocols).
- Secure upper layer network protocols (socket layer, IP layer).
- Secure lower layer network protocols (link encryptors).



Two types of cryptographic mechanisms can be used to provide encryption: symmetric cryptography, wherein entities share a common secret key, and public key cryptography (also known as asymmetric cryptography), in which each communicating entity has a unique key pair (a public key and a private key).

Implementation variables in providing encryption for protection of communications data include where in the protocol stack encryption takes place. Encryption at different layers provides different protections to the underlying data or protocol elements.

The strength of the confidentiality service may depend on a number of variables associated with the encryption function:

- The security protocol or application used to invoke the encryption function.
- The trust in the platform executing the protocol or application.
- The cryptographic algorithm.
- The length of the key(s) used for encryption/decryption.
- The protocol used to manage/generate those keys.
- The storage of secret keys (key management keys and encryption keys).

### 4.3.2.2 Data Separation

Data separation takes a different approach to preventing disclosure. Mechanisms that provide data separation prevent the adversary from getting at the data in the first place. This is achieved by using the normal access control mechanisms described in Section 4.4, Important Security Technologies, as well as by the additional techniques described below. An example of a commonly used data separation technique is not allowing data labeled as secret to flow onto an unclassified network.

Data separation mechanisms provide confidentiality by preventing data from reaching a location or destination where it could be disclosed to unauthorized entities. Mechanisms can be employed to prevent data from flowing into undesired areas (routing control). Other mechanisms may be employed to physically segregate those areas. Examples of routing control include a router that directs IP packets based on security labels, thereby preventing secret packets from reaching unclassified networks, and a firewall that scans e-mail messages for “dirty words” and prevents messages containing them from being released outside a local network. Examples of physically segregated data are isolated system high networks and physically protected wires.

Data separation mechanisms can be used to counter passive monitoring attacks, as well as insider attacks that inappropriately attempt to release information from a controlled area. The primary variable in the level of assurance provided by a data separation mechanism is the level of trust associated with the process or machine implementing the mechanism.

### 4.3.2.3 Traffic Flow Protection

Data padding can be employed to provide traffic flow protection. Addition of superfluous (usually random) data to data carried in a communications protocol can hide the characteristics (e.g., data rate, data frequency, etc.) of the underlying data. When combined with encryption, this mechanism also hides the content of the underlying data.

Address hiding can also be employed to provide traffic flow protection. Address hiding includes network address translation in which the IP addresses of machines in a local network are replaced by the address of a protecting firewall. Network layer addresses can be hidden by encrypted tunnels, which also provide data confidentiality.

### 4.3.2.4 Other Mechanisms

Other mechanisms for providing confidentiality include spread-spectrum and frequency hopping techniques.

## 4.3.3 Integrity

The integrity security service includes the following methods: prevention of unauthorized modification of data (both stored and communicated), detection and notification of unauthorized modification of data, and recording of all changes to data. Modification of both stored and communicated data may include changes, insertions, deletions, or duplications. Additional potential modifications that may result when data is exposed to communications channels include sequence changes and replay.

The requirements for provision of integrity security services are similar to those for confidentiality and include the location, type, and amount or parts of the data that needs protection.

When integrity is discussed with respect to network security, it is important to consider where in the protocol stack the integrity service is provided. Different implementation (layering) options will provide integrity to data in different protocol layers as well as to data being communicated. Sophisticated integrity schemes are likely to require service from the application using the data.

Note that integrity protection is of no value unless it is combined with a mechanism that provides authentication of the source. Without source authentication, anyone could tamper with the original data and then just reapply an integrity mechanism.

Data integrity can be divided into two types, based on the type of data to be protected. Integrity can be applied to a single data unit (protocol data unit, database element, file, etc.) or to a stream of data units (e.g., all protocol data units exchanged in a connection).

### 4.3.3.1 Single Unit of Data

Ensuring the integrity of a single data unit requires that the originating (sending) entity calculate an additional data item that is a function of (and bound to) the original data unit. This additional item is then carried along with the data unit. The entity that desires to verify the integrity of this data unit must recalculate the corresponding quantity and compare it with the transferred value. A failure of the two to match indicates that the data unit has been modified in transit.

Methods for calculating this data item, which is a function of the original data unit (the “check value”), vary in the processing required and the services provided. Checksums, cyclic redundancy check (CRC) values, and hashes (also known as a message digest) all meet the requirement that they depend on the entire content of the original data unit. A weakness of this method is that, if an adversary modifies the original data, these functions are easily reproducible and allow the adversary to generate a proper value for the modified data thereby defeating the integrity service. An additional mechanism can be applied to prevent access to the check value (e.g., encryption or digital signatures) to overcome this problem.

Another method of preventing successful modification of the check value is to include a secret value along with the original data unit. This property is exhibited by message authentication codes (also known as message integrity check and keyed hashes).

The icheck value alone will not protect against an attack that replays a single data unit. A time stamp may be included along with the original data unit to provide limited protection against replay.

### 4.3.3.2 Sequence of Data Units

To protect the integrity of a sequence of data units (i.e., protect against reordering, losing, replaying and inserting, or modifying data), some type of ordering information must be provided within the communications protocol. Examples of ordering information are sequence numbers and time stamps. Integrity of sequences can also be provided by encrypting the sequence of data units using a cryptographic algorithm in which encryption of each sequence depends on the encryption of all previous sequences (also referred to as chaining).

## 4.3.4 Availability

Availability is “timely, reliable access to data and information services for authorized users.” Availability in a networked environment includes not only the user’s ability to access hardware and software resources (such as user agents and servers) but also the user’s ability to obtain a desired quality of service or QoS (e.g., to make use of network bandwidth with reasonable throughput). Network traffic must be able to traverse LANs and wide area networks (WAN) as required to reach its intended destination.

One of the most effective methods of assuring availability is to provide a secure network environment that exhibits the common security services. Attacks that could prevent a networked system from providing availability may be countered by preventing unauthorized access to resources with access controls and protecting data from disclosure or modification with integrity and confidentiality services. Access control, integrity, and confidentiality become mechanisms to help support the availability security service.

Solutions to problems that affect availability include the following:

- **Protection from Attack.** Some network-based attacks are designed to destroy, degrade, or “crash” network resources. The solution is to harden these resources against such attacks. Means of doing this include closing security holes in operating systems or network configurations, limiting access to resources to authorized entities, and limiting an adversary’s ability to manipulate or view the data flowing through and to those resources (thus preventing insertion of harmful data, such as viruses, or disclosure of sensitive network data, such as routing tables).
- **Protection from Unauthorized Use.** Availability is also limited if a resource is in use, occupied, or overloaded. If unauthorized users are using limited resources (e.g., processing power, network bandwidth, or modem connections), the resources are not available for authorized users. Identifying and authenticating the users of these resources can provide access controls to limit unauthorized use. However, the process of requesting IA too frequently may be used to slow or stop network operations (i.e., nondelivery notice floods).
- **Resistance to Routine Failures.** Normal operational failures and acts of nature also contribute to loss of availability. Solutions include use of equipment designed for high reliability, redundancy in equipment, and network connectivity that provides multiple routes.

Trusted operating system concepts are also used to limit the harmful effects of network attacks. By containing the damage caused by malicious code and ensuring the proper operation of other security mechanisms, the trusted operating system preserves availability. Another feature exhibited by trusted operating systems is process integrity. This provides assurance that processes executing on an end system provide consistent, repeatable results that are not affected by undesired (unauthorized) influences.

Critical system components must also provide physical security, not only to prevent attacks or misuse of resources, but also to ensure that the platforms and applications are not modified to bypass the invocation of those security services that provide availability.

## 4.3.5 Nonrepudiation

Repudiation is denial by one of the entities involved in a communication that it participated in that communication. The nonrepudiation security service provides the ability to prove to a third

party that the entity did indeed participate in the communication. When discussed in the context of networking.

- Nonrepudiation, with proof of origin, provides the recipient of a data item with proof of the identity of the originator of that data item and the time of origination.
- Nonrepudiation, with proof of delivery, provides the originator of a data item with proof that the data item was delivered to the intended recipient (and in some cases, the time of receipt).
- Auditing services help enforce accountability of the parties involved in exchanges requiring nonrepudiation, by recording relevant events that can be traceable to persons who can be held responsible for their actions.

The nonrepudiation service is primarily provided by application layer protocols. Users are most often concerned with providing nonrepudiation for application data (such as an e-mail message or a file). Providing nonrepudiation at a lower protocol layer will only provide proof that a particular connection was made; it will not bind the data that flowed over that connection to a particular entity.

Nonrepudiation is provided by the authenticating characteristics of digital signatures. A digital signature on a data element (or on the hash of that element) irrevocably ties that data element to the identity contained in the public key certificate associated with the private key that generated the signature. Of course, data integrity must be provided to that data element to ensure that the element was not changed after the application of the signature.

Because nonrepudiation depends on an identity contained in a public key certificate, and certificates become invalid, it is important to be able to establish to a third party the validity of the certificate. It must be possible to prove the validity of that certificate at the time of the original communication and at any time in the future. This can be accomplished with a combination of trusted time stamps, third-party notaries, or archived CRLs.

Time stamping achieves the goal of establishing the time at which a communication or transaction occurred. For the highest levels of assurance, time stamps are applied by a trusted time stamping service that digitally signs the data item (or a hash of the data item) along with the time stamp before delivery to the intended recipient.

## 4.4 Important Security Technologies

An overview of technical security countermeasures would not be complete without at least a high-level description of the widely used technologies underlying those countermeasures. This section highlights selected technologies as an introduction to the detailed technology assessments included in Sections 5 through 9. For convenience, these technologies are listed alphabetically.

- **Application Layer Guard.** The need for a separate mechanism to perform a gatekeeper function, checking the invocation of security features, gives rise to a need for security at the application layer. This gatekeeper has recently taken the form of an application layer guard that implements firewall mechanisms (performing I&A functions and enforcing security policies, such as allowing or disallowing connections based on ID and/or requested protocol processing). Guard functionality includes such features as cryptographic invocation check on information that is allowed outside the protected enclave and data content filtering to support sensitivity regrade decisions. The guard functionality, while effective for non-real-time applications (e.g., e-mail) on networks with low sensitivity, has been difficult to scale to highly classified networks and real-time applications.
- **Application Program Interface (API).** APIs are a means of isolating a computing platform from the details of the implementation of cryptographic functions (both the actual algorithms and the hardware implementations). It provides standard interfaces so that multiple vendors can provide interoperable solutions.
- **Common Data Security Architecture (CDSA).** The CDSA is a set of layered security services that address communications and data security problems in the emerging Internet and intranet application space. CDSA focuses on security in peer-to-peer distributed systems with homogeneous and heterogeneous platform environments. The architecture also applies to the components of a client/server application. The CDSA addresses security issues and requirements in a broad range of applications by—
  - Providing layered security mechanisms (not policies).
  - Supporting application-specific policies by providing an extensibility mechanism that manages add-in (policy-specific) modules.
  - Supporting distinct user markets and product needs by providing a dynamically extensible security framework that securely adds new categories of security service.
  - Exposing flexible service provider interfaces that can accommodate a broad range of formats and protocols for certificates, cryptographic keys, policies, and documents.
  - Supporting existing, secure protocols, such as Secure Sockets Layer (SSL), Secure/Multipurpose Internet Mail Extension (S/MIME), and Secure Electronic Transaction (SET).
- **Circuit Proxy.** Circuit gateways are another type of proxy firewall. A circuit-level proxy becomes an intermediate connection point in a session between a client and a server. To reach a distant server, a client initially connects to a Transmission Control Protocol (TCP) port on the circuit proxy machine. The circuit proxy then completes the connection (after making an access control decision) to the target server. Access controls are based on the identity of the initiating machine without interpreting the application protocol or viewing the contents of protocol packets. A circuit-level proxy can be used across several application protocols; however, client modifications may be necessary to use the circuit-level protocol.
- **CryptoAPI.** The Microsoft Cryptographic API provides services that enable application developers to add cryptography to their Win32 applications. Applications can use the

functions in CryptoAPI without knowing anything about the underlying implementation, in much the same way that an application can use a graphics library without knowing anything about the particular graphics hardware configuration.

- **Cryptographic Service Providers (CSP).** Both CDSA and CryptoAPI make use of the concept of CSPs, which are independent modules that perform the real cryptographic work. Ideally, CSPs are written to be completely independent of any particular application, so that a given application will run with a variety of CSPs. In reality, however, some applications may have very specific needs that require a custom CSP.

A CSP may implement one or more of the following cryptographic functions: bulk encryption algorithm, digital signature algorithm, cryptographic hash algorithm, unique identification number, random number generator, secure key storage, and custom facilities unique to the CSP.

A CSP may be implemented in software, hardware, or both. The CSP or an independent module can also deliver key management services, such as key escrow or key recovery. CSPs should not reveal key material unless it has been wrapped. Also, the key-generation function of a CSP should be made as tamper resistant as possible.

- **File Encryptors.** These provide confidentiality and integrity for individual files, provide a means of authenticating a file's source, and allow the exchange of encrypted files between computers. File encryptors typically implement a graphical user interface (GUI) that allows users to choose files to be encrypted or decrypted. This protects individual files but does not protect all of the files on the drive.

Many applications generate temporary files that may contain user data. These files are normally erased when the application is closed; but when the application does not close in an orderly fashion, these temporary files may remain. In addition, some operating systems do not actually erase data when files are deleted. Instead, they alter the name of the file in the file allocation table. The user's data remains on the hard drive until the space is reallocated to another file and overwritten. Thus, unencrypted and potentially classified user data can remain on the hard drive after system shutdown, either through failure to erase temporary files or by design of the operating system's erasing function.

- **Hardware Tokens.** A number of hardware token approaches are available. The approaches range from a token that is an external memory device only to a token with significant levels of processing. One hardware token that is prominent in the Department of Defense (DoD) community is the FORTEZZA<sup>®</sup> Crypto Card. The FORTEZZA<sup>®</sup> card provides the cryptographic algorithms required to provide security services to a FORTEZZA<sup>®</sup>-based system. It stores the private key information for each user personality, the certificates of its issuers, and the public keys needed for cryptography. It also performs the digital signature and hash algorithms, public or private key exchange functions, encryption, and decryption. The interface to the card depends on the hardware platform and its configuration, and the operating system.

- **Intrusion and Penetration Detection.** Intrusion detection and response systems can protect either a network or individual client platforms. Effective intrusion detection systems detect both insider and outsider attacks. In general, intrusion detection systems are intended to protect against and respond to situations in which the available countermeasures have been penetrated, either through allowed usage or the exploitation of vulnerabilities that are unknown or have not been patched. The objective of these systems is to detect malicious and unintended data and actions (e.g., altered data, malicious executables, requests that permit unintended resource access, and unintended use of intended services). Once the intrusion is detected, an appropriate response is initiated (e.g., disconnect attacker; notify operator; respond automatically to halt or lessen the attack; trace attack to proper source; and counter the attack, if appropriate). Intrusion detection mechanisms operating at the transport layer can view the contents of transport packets (e.g., TCP packets) and are able to detect more sophisticated attacks than are mechanisms that operate at the network layer. Intrusion detection mechanisms operating at the network layer can view the contents of network packets (e.g., IP packets) and are thus only able to detect attacks that are manifested at the network layer (e.g., port scans).
- **Internet Protocol Security (IPSec).** IPSec is the security framework standardized by the IETF as the primary network layer protection mechanism. IPSec consists of two parts: an authentication header (AH), whose purpose is to bind the data content of IP frames to the identity of the originator, and an encapsulating security payload (ESP), for privacy. The AH is intended for use when integrity of information is required but privacy is not. ESP is intended for use where data confidentiality is required. ESP defines two methods (or modes) of encapsulating information. Tunnel mode, when used at an enclave boundary, aggregates traffic flow from site to site and thereby hides end-system identification. Transport mode leaves end-system identification in the clear and is most advantageous when implemented at the end system.
- **Internet Key Exchange (IKE) Protocol.** IKE was developed by the IETF as a standard for security attribute negotiation in an IP network. It provides a framework for creating security associations between endpoints on an IP network, as well as the methodology to complete the key exchange. IKE is based upon the Internet Security Association Key Management Protocol (ISAKMP) with Oakley extensions. The structure of ISAKMP is sufficiently flexible and extensible to allow inclusion of future security mechanisms and their associated algorithms and can be tailored to other networking technologies.
- **Media Encryptors.** Media encryptors protect the confidentiality and integrity of the contents of data storage media. They can also perform a role in maintaining the integrity of the workstation by verifying the Basic Input/Output System (BIOS) and ensuring that configuration and program files are not modified. Media encryptors need to leave some system files unencrypted so that the computer can boot from the hard drive. Most of these files can have their integrity protected by a cryptographic checksum; this will not prevent a tamper attack but will alert the user that the data has been altered. However, some system files contain data that changes when the computer is booted; these files cannot be protected. With the exception of some system files, media encryptors encrypt the entire contents of the drive.



## UNCLASSIFIED

Technical Security Countermeasures  
IATF Release 3.1—September 2002

- **Packet Filter.** Packet filtering firewalls (also called screening routers) commonly operate at the network layer (Open Systems Interconnection [OSI] Layer 3). These firewalls check the IP and protocol headers against a set of predefined rules. They can typically filter packets based on host and destination IP address, port number, and the interface. This type of firewall is generally inexpensive, fast, and transparent to the user. However, screening routers generally do not have a very robust auditing capability, nor do they allow the use of strong authentication on incoming connections. The combination of a packet filtering system and another product (authentication server) may provide strong authentication capability.
- **PKI Certificate Management Protocol (CMP).** For managing public key material, the Internet community has developed the Internet X.509 PKI CMP. Management protocols are required to support on-line interactions between PKI components. For example, a management protocol might be used for interactions between a CA and a client system with which a key pair is associated or between two CAs that cross-certify each other. At a high level, the set of operations for which management messages are defined can be grouped as follows:
  - **CA Establishment.** When establishing a new CA, certain steps are required (e.g., production of initial CRL, export of CA public key).
  - **End-Entity Initialization.** This includes importing a root CA public key and requesting information about the options supported by a PKI management entity.
  - **Certification.** Various operations result in the creation of new certificates:
    - Initial registration/certification
    - Key pair update
    - Certificate update
    - CA key pair update
    - Cross certification
    - Cross-certificate update.
  - **Certificate/CRL Discovery Operations.** Some PKI management operations result in the publication of certificates or CRLs:
    - Certificate publication
    - CRL publication.
  - **Recovery Operations.** Some PKI management operations are used when an end entity has “lost” its key material.
  - **Revocation Operations.** Some PKI operations result in the creation of new CRL entries and/or new CRLs.
- **SSL.** SSL exists just above the transport layer and provides security independent of application protocol, although its initial implementation was meant to secure the Hypertext Transfer Protocol (HTTP). This effort has migrated to the IETF as the Transport Layer Security (TLS) protocol, which provides data encryption, server authentication, message integrity, and optional client authentication for a TCP/IP connection. TLS negotiates the invocation of cryptographic algorithms (from a fixed set) and protects all application layer data.

- **S/MIME.** S/MIME is a specification for adding security for e-mail in Multipurpose Internet Mail Extensions format, supporting binary attachments as well as text. It offers authentication and confidentiality. S/MIME uses a hybrid approach to providing security, referred to as a digital envelope. The bulk message is encrypted with a symmetric cipher, a public key algorithm is used for key exchanges and for digital signatures, and X.509 certificates support authentication. S/MIME supports anonymity to the extent that it applies the digital signature first and then encloses the signature and the original message in an encrypted digital envelope, so that no signature information is exposed to a potential adversary.

The S/MIME specification is currently an Internet draft that recommends three symmetric encryption algorithms: Data Encryption Standard (DES), Triple-DES, and RC2 (a symmetric block cipher with a 40-bit key to meet the U.S. Government's export requirements). It also builds on the Public Key Cryptography Standards (PKCS), specifically PKCS #7, providing a flexible and extensible message format to represent the results of cryptographic operations, and PKCS #10, a message syntax for certification requests. The S/MIME specification has been submitted to the IETF in an effort to make it an industry-accepted standard.

- **SOCKS.** This protocol supports application-layer firewall traversal. The SOCKS protocol supports both reliable TCP and User Datagram Protocol (UDP) transport services by creating a shim-layer between the application and the transport layers. The SOCKS protocol includes a negotiation step whereby the server can dictate which authentication mechanism it supports. Compliant implementations must support Generic Security Services (GSS)—API and user name/password authentication modes.
- **Stateful Packet Filter.** Stateful packet filters look at the same headers as do packet filters, but also examine the content of the packet. In addition, this technology is capable of dynamically maintaining information about past packets or state information. Security decisions can then be based on this state information. Because they can retain state information, stateful packet filters permit UDP-based services (not commonly supported by firewalls) to pass through the firewall. Thus they are advertised as offering greater flexibility and scalability. Stateful packet filtering technology also allows logging and auditing and can provide strong authentication for certain services.
- **Trusted Computing Base (TCB).** A trusted computer system is a system that employs sufficient hardware and software assurance measures to allow its use for simultaneous processing of a range of sensitive or classified information. Such a system is often achieved by employing a TCB. A TCB is the totality of protection mechanisms within a computer system, including hardware, firmware, and software, the combination of which is responsible for enforcing a security policy. A TCB consists of one or more components that together enforce a unified security policy across a product or system. The TCB's ability to correctly enforce a unified security policy depends solely on the mechanisms within the TCB and on system administration personnel's correct input of parameters (e.g., a user's clearance level) related to the security policy.

- **Virus Detectors.** Virus detectors can be used to protect a network or an individual client. A virus can be considered a special form of intrusion involving the classic Trojan horse attack with the ability to reproduce and spread. The virus is normally considered to be limited to the authorizations of the user who is executing the code, but viruses may also exploit flaws in the network that allow them to cause a serious privilege state harm.

## 4.5 Robustness Strategy

### Purpose

The robustness strategy, when completed in a later release of the IATF, will provide guidance on assessing the degree of robustness. This is defined as the level of security mechanism strength and assurances recommended (considered “good enough”) for an Information Systems Security (INFOSEC) solution. At its current stage of development, the strategy deals primarily with the levels within individual security services and mechanisms, based on information on a given value in a particular (static) threat environment. As discussed below, this strategy is not a complete answer, and is not intended to provide an endorsement or credentials for specific products. It also is not intended as a “recipe” for robust solutions; rather, it offers security engineering guidance to the developers, integrators, and risk managers engaged in risk management. Users of the IATF can employ the robustness strategy to—

- Help developers and integrators assess what strength of mechanisms, what levels of assurance (in development methodology, evaluation, and testing) and what criteria are recommended for a particular configuration meant to protect information of a particular value; with a specific intelligence life; in a specific, static threat environment.
- Define product requirements for different customer scenarios (value of information, threat, configuration, etc.), for example, as described in the IATF.
- Provide feedback to security requirements developers, decision makers, customer representatives, customers, etc.
- Constitute developmental requirements when a security solution does not exist.
- Work with academe to foster research in the network security arena and to educate future engineers, architects, and users on network security technology.
- Perform subsequent risk assessments made necessary by reconfiguration of the system or network under review or by a change in threat or value of information.

As technology in general and INFOSEC threats in particular evolve, countermeasures must also evolve, and with them the corresponding application guidance. This paper is a strategy for the development of a general security mechanism and countermeasure valuation scheme. Rather than directly defining the security requirements that must be met, it characterizes the relative strength of mechanisms that provide security services and provides guidance on selecting these mechanisms.

Trained information systems security engineers [11] support customer organizations in defining and applying security solutions to address the organization's information assurance (IA) needs. Working with a customer from initial contact through solution acceptance, the systems security engineer helps ensure that the customer's security needs are appropriately identified and that acceptable solutions are developed. Within the context of the IATF robustness strategy, he or she helps the organization assess the value of its information and assets and the security threat within the operational environment, identifies the security services necessary to provide appropriate protection, and provides guidance on the characteristics of the specific security mechanisms that provide those services.

Different applications of the same system or environment but by differently trained systems security engineers may result in different guidance, although all such outcomes would be consistent with the recommended use of the strategy. There is no concept of official "compliance" with the robustness strategy as a condition for approval of a solution. Rather, the strategy is an aid to "get you there".

## **Robustness Strategy Section Overview**

Section 4.5.1 describes the general process including assumptions and output. Section 4.5.2 presents an approach for determining recommended robustness levels (strength of mechanism and assurance) based on the value of information to be protected and the threat environment. Section 4.5.3 breaks down security services into supporting mechanisms and identifies corresponding strength levels. The Level of Assurance section (Section 4.5.4) discusses related aspects of obtaining assurance. Section 4.5.5 demonstrates how the process would be applied in developing specific guidance. These sections are followed by a discussion of robustness strategy evolution (Section 4.5.6), which provides recommendations for those who would carry on the work outlined in this document. Finally, Section 4.5.7, demonstrates real-world application of the robustness strategy.

### **4.5.1 Overview of the General Process**

The robustness strategy is intended for application in the development of a security solution and is meant to be consistent with IATF Chapter 3, Information Systems Security Engineering, which describes the overall process. An integral part of the process is determining the recommended strength and degree of assurance for proposed security services and mechanisms that become part of the solution set. The strength and assurance features provide the basis for the selection of the proposed mechanisms and a means of evaluating the products that implement those mechanisms. This section provides guidance on determining recommended strength and assurance.

This process should be applied to all components of a solution, both products and systems, to determine the robustness of configured systems and their component parts. It applies to commercial off-the-shelf (COTS), government off-the-shelf (GOTS), and hybrid solutions. As indicated above, the process is to be used by security requirements developers, decision makers, information systems security engineers, customers, and others involved in the solution life cycle.

Clearly, if a solution component is modified, or threat levels or the value of information changes, risk must be reassessed with respect to the new configuration.

Various risk factors, such as the degree of damage that would be suffered if the security policy were violated, threat environment, and so on, will be used to guide determination of an appropriate strength and an associated level of assurance for each mechanism. Specifically, the value of the information to be protected and the perceived threat environment are used to obtain guidance on the recommended strength of mechanism level (SML) and evaluation assurance level (EAL).

## 4.5.2 Determining the Degree of Robustness

We define the degree of robustness as the level of strength and assurance recommended for potential security mechanism(s). To determine this level for a given security service in a particular application, the customer and the information systems security engineer should consider the value of the information to be protected (in relation to the operational mission), and the perceived threat environment. Guidelines for determining these values are provided below. Once a determination has been made regarding the information value and threat environment, the security engineer uses the robustness table, Table 4-7, to determine required EALs and SMLs.

**Table 4-7. Degree of Robustness**

Information Value	Threat Levels						
	T1	T2	T3	T4	T5	T6	T7
<b>V1</b>	SML1 EAL1	SML1 EAL1	SML1 EAL1	SML1 EAL2	SML1 EAL2	SML1 EAL2	SML1 EAL2
<b>V2</b>	SML1 EAL1	SML1 EAL1	SML1 EAL1	SML2 EAL2	SML2 EAL2	SML2 EAL3	SML2 EAL3
<b>V3</b>	SML1 EAL1	SML1 EAL2	SML1 EAL2	SML2 EAL3	SML2 EAL3	SML2 EAL4	SML2 EAL4
<b>V4</b>	SML2 EAL1	SML2 EAL2	SML2 EAL3	SML3 EAL4	SML3 EAL5	SML3 EAL5	SML3 EAL6
<b>V5</b>	SML2 EAL2	SML2 EAL3	SML3 EAL4	SML3 EAL5	SML3 EAL6	SML3 EAL6	SML3 EAL7

The robustness strategy focuses specifically on individual security services and mechanisms. When the robustness of an overall network solution is considered, the individual solutions at each layer within the network must also be considered. IA mechanisms can be applied at the host, subnet, boundary, and backbone levels. Robustness should take into account the implications of composing layered protection mechanisms and also incorporates an overall assessment of vulnerabilities and residual risks for each layer.

Many customers, in support of their mission, must protect information or an information system whose compromise could adversely affect the security, safety, financial posture, or infrastructure of the organization. Five levels of information value have been defined:

- **V1.** Violation of the information protection policy would have negligible adverse effects or consequences.
- **V2.** Violation of the information protection policy would adversely affect and/or cause minimal damage to the security, safety, financial posture, or infrastructure of the organization.
- **V3.** Violation of the information protection policy would cause some damage to the security, safety, financial posture, or infrastructure of the organization.
- **V4.** Violation of the information protection policy would cause serious damage to the security, safety, financial posture, or infrastructure of the organization.
- **V5.** Violation of the information protection policy would cause exceptionally grave damage to the security, safety, financial posture, or infrastructure of the organization.

Similarly, the customer must work with a systems security engineer to define the threat environment in which the mission will be accomplished. Factors to consider when determining the threat to a particular solution include level of access, risk tolerance, expertise, and resources available to the adversary. These threats should be considered in the context of the system security policy.

The following threat levels were derived from various relevant works (e.g., Security Management Infrastructure [SMI] Task 1 Team, Threat and Vulnerability Model for Information Security, 1997 [12]), and discussions with subject matter experts throughout the Information Systems Security Organization (ISSO):

- **T1.** Inadvertent or accidental events (e.g., tripping over a power cord).
- **T2.** Passive, casual adversary with minimal resources who is willing to take little risk (e.g., listening).
- **T3.** Adversary with minimal resources who is willing to take significant risk (e.g., unsophisticated hackers).
- **T4.** Sophisticated adversary with moderate resources who is willing to take little risk (e.g., organized crime, sophisticated hackers, international corporations).
- **T5.** Sophisticated adversary with moderate resources who is willing to take significant risk (e.g., international terrorists).
- **T6.** Extremely sophisticated adversary with abundant resources who is willing to take little risk (e.g., well-funded national laboratory, nation-state, international corporation).

- **T7.** Extremely sophisticated adversary with abundant resources who is willing to take extreme risk (e.g., nation-states in time of crisis).

After a determination is made regarding the value of the information to be protected and the threat environment, the systems security engineer can provide guidance on how strong the security mechanism should be and what assurance activities that should be performed. Table 4-7 indicates the minimal recommended SML and EAL [6] for protecting information or information systems of a given value (V1 to V5) against a given threat level (T1 to T7). EALs are defined in Sections 4.5.3 and 4.5.4, respectively.

Using an applicable capability maturity model (CMM), Capability Level 2 or the equivalent is recommended for EALs 1 to 3 and Capability Level 3 or the equivalent is recommended for EALs 4 to 7. A CMM describes the stages through which processes advance as they are defined, implemented, and improved.<sup>1</sup>

One example of an applicable CMM is the SSE-CMM. The SSE-CMM is designed to support a host of improvement activities, including self-administered appraisals or internal appraisals augmented by experts (e.g., information systems security engineers) from inside or outside of the organization.<sup>2</sup>

The systems security engineer, working with the customer, would apply the SSE-CMM (or another applicable CMM) as a baseline capability. The assessment of compliance would still be left to the discretion of the customer. Reasonable justification is still necessary, and it should be denoted that acquisition personnel must be knowledgeable about the CMM used.

### 4.5.3 Strength of Mechanism

SML are presented in a series of tables focusing on specific security services. Since robustness strategy is still being formulated, these tables are not yet considered complete or adequately refined. There are still a number of additional security mechanisms that are not detailed in the tables but that may be appropriate for providing some security services. Further, the strategy is not intended, by itself, to provide adequate information for selection of the desired (or sufficient) mechanisms for a particular situation. An effective security solution will result only from the proper application of ISSE skills to specific operational and threat situations. The strategy does offer a methodology for structuring a more detailed analysis. The security services itemized in these tables have several supporting services that may result in recommendations for inclusion of additional security mechanisms and techniques.

For each service, guidance on each SML is given for the various mechanisms that provide the overall service. In some cases, a group of mechanisms will be required to provide the necessary protection. It should also be noted that a systems security engineer, in conjunction with a customer, could decide to use a stronger or weaker mechanism than is recommended, depending

---

<sup>1</sup> System Security Engineering Capability Maturity Model Description document

<sup>2</sup> System Security Engineering Capability Maturity Model Summary

on the environment. It is the intent of the strategy to ensure that mechanisms across services at the same strength level provide comparable protection, in that they counter equivalent threats. The selection of mechanisms from the service tables is an independent event, in the sense that one mechanism does not necessarily require others. Higher strength mechanisms do not necessarily contain features of lower strength mechanisms (i.e., security functions do not necessarily accumulate at higher strength levels). Table entries are preliminary estimates based on consultation with subject matter experts and are likely to be revised based on technology evolution, threat assessment, and cost development.

The strength referred to below is a *relative* measure of the effort (cost) required to defeat the mechanism and is not necessarily related to the cost of implementing such countermeasures. All things being equal (especially cost), the highest strength mechanism should always be chosen. Three SMLs are defined:

- **SML1** is defined as basic strength or good commercial practice. It is resistant to unsophisticated threats (roughly comparable to T1 to T3 threat levels) and is used to protect low-value data. Examples of countered threats might be door rattlers, ankle biters, and inadvertent errors.
- **SML2** is defined as medium strength. It is resistant to sophisticated threats (roughly comparable to T4 to T5 threat levels) and is used to protect medium-value data. It would typically counter a threat from an organized effort (e.g., an organized group of hackers).
- **SML3** is defined as high strength or high grade. It is resistant to the national laboratory or nation-state threat (roughly comparable to T6 to T7 threat levels) and is used to protect high-value data. Examples of the threats countered by this SML are an extremely sophisticated, well-funded technical laboratory and a nation-state adversary.

Based on these definitions, the customer and the systems security engineer will apply their knowledge of the specific operational and threat situation to determine what strength of mechanism is recommended for each of the mechanisms listed in the following sections.

### 4.5.3.1 Mechanisms Supporting Security Management

Recommended mechanisms for establishing needed security management are depicted in Table 4-8. The degree of awareness and control with respect to the following will identify the SML target.

- **Compromise Recovery.** In addition to achieving a secure initial state, secure systems must have a well-defined status after failure, either to a secure failure state or via a recovery procedure to a known secure state.
- **Poor System Administration.** This is a leading cause of security weaknesses and vulnerabilities. It is the first line of defense in enforcing the security policy. (See IATF



Chapter 3, Information Systems Security Engineering for more information on system security administration.)

- **Training.** Operators and users require training on security features and system operation. Knowledgeable users are more likely to exercise due care in protecting information assets.
- **Operational Security (OPSEC) Process.** This process is a coordinated, multidisciplinary, five-step activity involving identification of critical information, threat identification and analysis, vulnerability identification and analysis, risk assessment, and adoption of countermeasures. Each use of the process addresses, and is adapted to, a specific activity of concern, which is examined for potential disclosure to specific adversaries, upon which to base directly pertinent countermeasures. Consult with the interagency operation support staff for consideration of individual cases.
- **Trusted Distribution.** This is a calculated/controlled method of distributing security-critical hardware, software, and firmware components. It protects the system from modification during distribution and detects any changes.
- **Secure Operations.** This is the level of standard operating procedures needed to provide security given the classification, sensitivity, and criticality of the data and resources being handled or managed. Secure operations includes security doctrine.
- **Mechanism Management.** Certain security mechanisms (e.g., cryptographic algorithms) have ancillary support needs (e.g., key management).

**Table 4-8. Security Management Mechanisms**

	Compromise Recovery	System Administration	Training	OPSEC	Trusted Distribution	Secure Operations	Mechanism Management
<b>SML1</b>	Informal plan	See Ch. 4, Countermeasures	Training available at user's discretion	Implementing OPSEC at user's discretion	Direct vendor purchase	Informal plan of operation	Procedural, at user's discretion
<b>SML2</b>	Detailed plan that is reviewed and approved	See Ch. 4, Countermeasures	Formal training plan	OPSEC training required; implementation at user's discretion	Certificate of authenticity, virus scan, validation	Formal plan of operation	Procedural, reminders, at user's discretion
<b>SML3</b>	Detailed plan that is reviewed and approved	See Ch. 4, Countermeasures	Knowledge / skill certification required	OPSEC training required, implementation required	Protective packaging, checksums, validation suite	Detailed, formal plan of operation	Automated support

### 4.5.3.2 Mechanisms Supporting Confidentiality

Confidentiality is the protection of information against disclosure to unauthorized entities or processes. Possible security mechanisms for this security service are depicted in Table 4-9. These mechanisms can be obtained individually or in combination.

- If cryptographic algorithm is chosen, some factors that must be considered are the management of keying material and the effective length of the key, which includes the strength of the underlying cryptographic algorithm. Effective key length is defined as the nominal key length, reduced by the effect of any known attacks against the cryptographic algorithm (assuming correct implementation). The supporting KMI [9] categories are defined in Chapter 8, Supporting Infrastructures.
- Physical security includes tangible security mechanisms, such as guards, locks, and fences. The idea is to build a physically secure enclave, providing guards and high walls.

**Table 4-9. Confidentiality Mechanisms**

	Cryptographic Algorithm		Physical Security	Technical Security		Anonymity	
	Effective Key Length	Key Management		Anti tamper	TEMPEST	TRANSEC	Cover & Deception
<b>SML1</b>	40+ bits symmetric key length, 80+ exponent 512+ modulus public key length	SMI Cat X, 80+ exponent 512+ modulus public key length, 80+ hash key length	Comparable to [7]	[6] Level 1 or 2	Comply with applicable EMI/EMC Federal Communications Commission standards or portions of [8]	Low power unit	TBD
<b>SML2</b>	80+ bits symmetric key length, 160+ exponent 1024+ modulus public key length	SMI Cat Y, 160+ exponent 1024+ modulus public key length, 160+ hash key length	Comparable to [7]	[6] level 3 or 4	[8]	Commercial spread spectrum signal techniques	TBD
<b>SML3</b>	Because of the complicated nature of this level, consult a qualified systems security engineer. <sup>3</sup>	SMI Cat Z, also consult with a qualified systems security engineer. <sup>3</sup>	Comparable to [7]	[6] level 4 or better	[8]	cryptographic spread-spectrum signal techniques	TBD

<sup>3</sup> DoD users should consult with a National Security Agency information systems security engineer. Other government users are directed to contact an information systems security engineer at the National Institute of Standards and Technology for

- Technical security is a protection mechanism for hardware. Tampering is unauthorized modification that alters the proper functioning of an information security device or system in a manner that degrades the security or functionality it provides. Antitamper mechanisms detect such alterations. TEMPEST is the investigation, study, and control of compromising emanations from telecommunications and automated information system (AIS) equipment.
- Anonymity is the desire for a user to remain unknown during a virtual transaction. Some applications requiring anonymity might be Internet voting and Internet cash. This area is relatively immature and is currently addressed by the transmission security (TRANSEC)[10] and cover and deception disciplines. TRANSEC mechanisms provide various degrees of covertness to prevent detection, identification, and exploitation. Cover and deception can be provided through such mechanisms as anonymous remailers, “onion routing,” or “Web anonymizers.” Cover-and-deception currently has no differentiated levels.

### 4.5.3.3 Mechanisms Supporting Integrity

Table 4-10 shows four mechanisms that, singly or in combination, will help ensure integrity. In the current context, integrity, as a security service, means protection of information against undetected, unauthorized modification or undetected destruction.

**Table 4-10. Integrity Mechanisms**

	Cryptographic Algorithm		Physical Security	Signature Checksum	Redundancy
	Effective Key Length	Key Management			
<b>SML1</b>	40+ bits symmetric key length, 80+ exponent 512+ modulus public key length	SMI Cat., 80+ exponent 512+ modulus public key length, 80+ hash key length	Comparable to [7]	Parity, or commercial checksum, hash, and signature with SML1 algorithm	Not applicable
<b>SML2</b>	80+ bits symmetric key length, 160+ exponent 1024+ modulus public key length	SMI Cat, 160+ exponent 1024+ modulus public key length, 160+ hash key length	Comparable to [7]	Cryptographic checksum, hash, and signature with SML2 algorithm	Redundant data path with 100 percent correct comparison
<b>SML3</b>	Due to the complicated nature of this level, consult a qualified information systems security engineer. <sup>4</sup>	SMI Cat, also consult a qualified information systems security engineer. <sup>5</sup>	Comparable to [7]	Cryptographic checksum, hash, and signature with SML3 algorithm	Multiple data paths with 100 percent correct comparison

guidance. Nongovernment users should consult a qualified information systems security engineer, or an equivalent representative within their organization.

<sup>4</sup> DoD users should consult with a National Security Agency information systems security engineer. Other government users are directed to contact an information systems security engineer at the National Institute of Standards and Technology for

- A cryptographic algorithm in an error extension mode will emphasize the error and should be used in conjunction with a detection mechanism (e.g., parity or human review).
- Physical security is described in Table 4-9.
- Signature Checksum provides data integrity by digitally signing data. Typically, the data requiring protection is used to calculate a smaller value, such as a parity, checksum, or hash. This value can then be digitally signed.
- Redundancy is the availability of multiple methods to obtain the same information.

### 4.5.3.4 Mechanisms Supporting Availability

Availability is also known as service assurance. To ensure availability of data, the system must employ both preventive and recovery mechanisms. This security service is quantified in Table 4-11 and can be obtained through a combination of the services as appropriate for the applications.

- TRANSEC is used to overpower potential jammers. A strong enough signal is provided for this antijam capability. TRANSEC can also be used to hide a signal to prevent jamming. (Note that, because of the real-time nature of exploitation, it may not be necessary to use an SML3 algorithm strength to meet the SML3 level for this mechanism.)
- Antitamper mechanisms are described in Table 4-9.
- Physical security is described in Table 4-9.
- Redundancy or redundant paths should be available to allow information flow without violating the site security policy. Such information flow might include bypassing any problem areas, including congested servers, hubs, cryptography, and so on.
- Data recovery is the ability to recover data that might otherwise be unavailable due to the loss of key, storage media, etc.

---

guidance in this area. Nongovernment users should consult a qualified information systems security engineer or an equivalent representative within their organization.

<sup>5</sup> DoD users should consult with a National Security Agency ISSE. Other government users are directed to contact an ISSE at the National Institute of Standards and Technology for guidance in this area. Non-government users should consult with a qualified ISSE or an equivalent representative within their organization.

**Table 4-11. Availability Mechanisms**

	<b>TRANSEC</b>	<b>Antitamper</b>	<b>Physical Security</b>	<b>Redundancy</b>	<b>Data Recovery</b>
<b>SML1</b>	High power	Level 1 or 2 [4]	Comparable to [7]	Bypass channel available	Informal archival plan, user backs up own key or data
<b>SML2</b>	Commercial spread spectrum signal techniques	Level 3 or 4 [4]	Comparable to [7]	Backup data path, hot spare	Formal archival plan, central backups
<b>SML3</b>	Cryptographic spread-spectrum signal techniques	Level 4 or better [4]	Comparable to [7]	Multiple data paths, multiple hot spares	Formal archival plan, central, off-site backups

### 4.5.3.5 Mechanisms Supporting I&A

I&A is required for effective access control. This usually includes a process for enabling recognition of an entity within or by an AIS and a security measure for establishing the validity of a transmission, message, or originator or verifying an individual's eligibility to receive specific categories of information. These attributes of I&A are listed in Table 4-12 and can be described as follows:

- Identification, or system identification (SID) in particular, is one way in which a system might recognize the entity (which may be a person) requesting authentication. Biometrics might be used to identify a living person.
- Human-to-machine authentication could use alphanumeric phrases, like passwords, personal identification numbers (PIN), or challenge, response exchanges that are memorized by a human or used with a token calculator. Physical devices, such as hardware tokens also provide such authentication (e.g., a credit card-type physical entity).
- Peer-to-peer authentication can use certificates to identify and authenticate entities. Such certificates are bound to the entity by a SML cryptographic algorithm, with a digital signature. Authentication is provided by a trusted third party (a separate, but knowledgeable entity). Within this area, one could use a cryptographic algorithm (as discussed under Confidentiality, above) and personnel security policy, in which a security clearance is obtained for a particular person to reduce the risk of an insider's attacking the system.

Table 4-12. I&amp;A Mechanisms

	Identification		Human-to-Machine Authentication		Peer-to-Peer Authentication			
	System IDs	Bio-metrics	Passwords PINS Challenge/Response	Tokens	Certificates	Cryptographic Algorithm		Personnel Security
						Effective Key Length	Key Management	
<b>SML1</b>	Uniqueness	Not applicable	Use of any of these methods.	Badge/ key static	Bind with SML1 cryptographic algorithm	40+ bits symmetric key length, 80+ exponent 512+ modulus public key length	SMI Cat. X, 80+ exponent 512+ modulus public key length, 80+ hash key length	Commercial hiring practices
<b>SML2</b>	Uniqueness and minimum character length	Use of any biometric method	Minimum effective length – TBD	Memory device, updated periodically	Bind with SML2 cryptographic algorithm	80+ bits symmetric key length, 160+ exponent 1024+ modulus public key length	SMI Cat Y, 160+ exponent 1024+ modulus public key length, 160+ hash key length	Equivalent of secret clearance
<b>SML3</b>	Uniqueness and minimum number of characters, minimum distance (e.g., Hamming)	Use of any biometric mechanism with a liveness test	Minimum effective length - TBD	CIK, updated every time	Bind with SML3 cryptographic algorithm	Because of the complicated nature of this level, consult a qualified systems security engineer 6	SMI Cat Z, also consult with a qualified systems security engineer. <sup>6</sup>	Equivalent of top secret clearance

### 4.5.3.6 Mechanisms Supporting Access Control

Beyond I&A, access control can be thought of as a “super service” encompassing all security services. In the context of network security, access control is concerned with limiting access to networked resources (hardware and software) and data (stored and communicated). The primary goal here is to prevent unauthorized use, unauthorized disclosure, or modification of data by unauthorized entities. A secondary goal is to prevent an availability attack (e.g., denial-of-service attack). Several mechanisms that help provide the access control service are shown in Table 4-13.

<sup>6</sup> DoD users should consult with a National Security Agency information systems security engineer. Other government users are directed to contact an information systems security engineer at the National Institute of Standards and Technology for guidance in this area. Nongovernment users should consult with a qualified ISSE, or an equivalent representative within their organization.

**UNCLASSIFIED**

The mechanisms in Table 4-13 can be described as follows:

- Antitamper is described under Confidentiality in Table 4-9.
- Mandatory access control (MAC) consists of the system’s automatic imposition of authorized access to data through use of labels and the binding of those labels to the associated data. In implementing MAC, one must consider both the integrity of the label itself and the strength of the binding between the label and the data. In other words, if SML2 is required for MAC, the integrity of the label must be provided with SML2 and the function (possibly a cryptographic algorithm) binding the label to the data must also be SML2. Other implementation concerns include making the labeling non-bypassable and fail-safe.
- Discretionary access control (DAC) is different from MAC in that the choice of who can and cannot be given authorized access to the data is made by the owner of the data to be accessed rather than by the machine. For SML1, this is comparable to setting UNIX permission bits (owner/group/world) to grant access. For SML2 and SML3, use of ACLs further refines the mechanism. ACLs can specifically allow certain identities access to information (e.g., specific users within a group can be granted access). Again, DAC mechanisms should be non-bypassable (changeable only by the owner of the data) and fail-safe, and should possess the same SML level of integrity as that associated with the required level of DAC.
- Certificates are described in Table 4-12.
- Personnel security is described in Table 4-12.

**Table 4-13. Access Control Mechanisms**

	<b>Anti-Tamper</b>	<b>Mandatory Access Control</b>	<b>Discretionary Access Control</b>	<b>Certificates</b>	<b>Personnel Security</b>
<b>SML1</b>	Level 1 or 2 [4]	Not applicable	Comparable to UNIX permission bits	Bind with SML1 cryptographic algorithm	Commercial hiring practices
<b>SML2</b>	Level 3 or 4 [4]	Labels bound to data having both integrity and binding function at the SML2 level	ACLs	Bind with SML2 cryptographic algorithm	Equivalent of secret clearance
<b>SML3</b>	Level 4 or better [4]	Labels bound to data having both integrity and binding function at the SML3 level	ACLs	Bind with SML3 cryptographic algorithm	Equivalent of top secret clearance

### 4.5.3.7 Mechanisms Supporting Accountability

Accountability can be considered a special type of nonrepudiation. The accountability security service is basically holding each network entity responsible for its actions on that network. Mechanisms that can be used to provide the security service of accountability are shown in Table 4-14 and discussed below.

- When implementing the audit mechanism, the following components should be considered.
  - What is being audited and what relevant events are detected.
  - How the audit (detected) data is protected, analyzed, and reported.
  - What the reaction strategy is to the audit data analysis and reporting.

These components should be considered for each SML level, and in SML2 and 3, should be detailed in a plan. As with all mechanisms, consideration should be given to noncircumvention or non-bypassability and the effects of failure.

- Intrusion detection is still in relativinfancy. This mechanism monitors a network and detects either (1) known attacks being mounted against the system or (2) differences in a profiled use of the system. Several aspects may be associated with an intrusion detection mechanism—for example, whether it is static (SML1) i.e., set up to filter only on known attacks and profiles; dynamic (SML2), i.e., set up to filter on known attacks and profiles but updatable perhaps through software downloads; or dynamically adaptable (SML3) incorporating the aspect of “artificial intelligence” in which the system learns new profiles based on usage. Depending on the SML level, a reaction mechanism to a detected intrusion must be either informally (SML1) or formally (SML2 and SML3) detailed and implemented.
- I&A is described in Table 4-12.

**Table 4-14. Accountability Mechanisms**

	<b>Audit</b>	<b>Intrusion Detection</b>	<b>I&amp;A</b>
<b>SML1</b>	Informal reaction mechanism	Static system with informal reaction mechanism	See Table 4-12 for SML1
<b>SML2</b>	Formal reaction plan and strategy	Dynamic system with formal reaction mechanism	See Table 4-12 for SML2
<b>SML3</b>	Formal reaction plan and strategy	Dynamic, adaptive system with formal reaction mechanism	See Table 4-12 for SML3

### 4.5.3.8 Mechanisms Supporting Nonrepudiation

The security service of nonrepudiation provides the sender of data with proof of delivery and the recipient with assurance of the sender’s identity, so that neither can later deny processing the



data. Table 4-15 shows the various mechanisms for providing this service at various security levels. These mechanisms are described below:

- Signature is used to digitally sign data in such a way that only the sender and receiver could have respectively sent and received the message. The sender signs the original data to prove that it was sent. The receiver signs a receipt as proof of receipt of the original data. Validation of these signatures is always required.
- The trusted third party mechanism is used to prearrange a method by which a third party may receive the information from the sender and transmit it to the receiver in a way that ensures that the sender and receiver are confident that they are communicating with the correct party.
- Accountability is described in Section 4.5.3.7. in Table 4-14
- I&A is described in Section 4.5.3.5. Table 4-12.
- Archive is the ability to store data so that it can be recovered if necessary.

**Table 4-15. Nonrepudiation Mechanisms**

	<b>Signature</b>	<b>Trusted Third Party</b>	<b>Accountability</b>	<b>I&amp;A</b>	<b>Archive</b>
<b>SML1</b>	Sign with SML1 cryptographic algorithm	See Table 4-12, Personnel Security for SML1	See Table 4-12 for SML1	See Table 4-12 for SML1	Informal archival plan, user backs up own key or data
<b>SML2</b>	Sign with SML2 cryptographic algorithm	See Table 4-12, Personnel Security for SML2	See Table 4-12 for SML2	See Table 4-12 for SML2	Formal archival plan, central backups
<b>SML3</b>	Sign with SML3 cryptographic algorithm	See Table 4-12, Personnel Security for SML3	See Table 4-12 for SML3	See Table 4-12 for SML3	Formal archival plan, central, off-site backups

## 4.5.4 Level of Assurance

The discussion of the need to view strength of mechanisms from an overall system security solution perspective is also relevant to level of assurance. Again, while an underlying methodology is offered, a real solution can only be deemed effective after a detailed analysis that considers the specific operational and threat situations and the system context for the solution.

Assurance is the measure of confidence in the ability of the security features and architecture of an automated information system to appropriately mediate access and enforce the security policy. The assurance measures listed here are from the Common Criteria [6].

The Common Criteria provide assurance through active investigation. Such investigation is an evaluation of the actual product or system to determine its actual security properties. The Common Criteria philosophy assumes that greater assurance results come from greater evaluation efforts in terms of scope, depth, and rigor. This approach has led to the seven EALs described below:

- **EAL 1, Functionally Tested.** Applicable where some confidence in correct operation is required, but when the threats to security are not viewed as serious. This EAL is of value where independent assurance is required to support the contention that due care has been exercised with respect to the protection. An example is the protection of personal information.
- **EAL 2, Structurally Tested.** Requires the cooperation of the developer in the delivery of design information and test results, but should not demand more effort (or substantially increased cost or time) than is consistent with good commercial practice. This EAL is applicable where a low to moderate level of independently assured security is required in the absence of an available development record. An example is securing legacy systems, or cases in which access to the developer is limited.
- **EAL 3, Methodically Tested and Checked.** Permits a conscientious developer to gain maximum assurance from positive security engineering at the design stage without substantial alteration of existing sound development practices. It is applicable where a moderate level of independently assured security is required.
- **EAL 4, Methodically Designed, Tested, and Reviewed.** Permits a developer to gain maximum assurance from positive security engineering based on good commercial development practices, which, though rigorous, do not require substantial specialist knowledge, skills, and other resources. This is the highest level at which it is likely to be economically feasible to retrofit to an existing product line. It is applicable in those circumstances in which a moderate to high level of independently assured security in conventional products is required, and where developers or users are prepared to incur additional security-specific engineering costs.
- **EAL 5, Semiformally Designed and Tested.** Permits a developer to gain maximum assurance from security engineering based on rigorous commercial development

practices supported by moderate application of specialized security engineering techniques. This EAL is applicable where a high level of independently assured security in a planned development is required along with a rigorous development approach.

- **EAL 6, Semiformally Verified Design and Tested.** Permits developers to gain high assurance from application of security engineering techniques to a rigorous development environment to protect high value assets against significant risks. It is applicable to the development of security products that will be used in high-risk situations.
- **EAL 7, Formally Verified Design and Tested.** Applicable to the development of products to be used in extremely high risk situations and/or where the high value of the assets justifies the higher costs. Realistically, it is limited to products with tightly focused functionality that is amenable to extensive formal analysis.

These assurance levels are composed of the following assurance classes: configuration management, delivery and operation, development, guidance documents, life-cycle support, tests, and vulnerability assessments. These classes incorporate the concepts of correct implementation, non-bypassable mechanisms, failure to a secure state, secure start-up, and others.

In addition to the tasks addressed in the Common Criteria, there are other assurance tasks that the Common Criteria do not discuss, including failure analysis and test, TEMPEST analysis and test, and tamper analysis and test. If these apply to a particular product or system, they should be added to the requirements of the appropriate EALs.

## 4.5.5 Examples of Process Application

Assumptions for these examples are as follows:

- Security evaluation is a necessary part of solution development.
- A trained information systems security engineer (or equivalent) is the strategy consumer.

The methodology for correct employment of the robustness strategy is as follows:

- The responsible customer party knows, and has appropriately documented, mission objectives, concept of operation, value of information to be protected, threat environment context, and security policy.
- A solution is then engineered according to IATF Chapters 5 through 9, providing guidance on the security mechanisms required.
- Risk factors (e.g., degree of damage if security policy is violated, threat environment) are used to help determine the appropriate strength and associated level of assurance for each mechanism in the set of security service tables. The risk addressed is the residual risk, not the overall (or initial) risk, that is, what remains after other countermeasures have been applied, and what would be the target of doctrine if additional security measures were not taken. For example, a system high workstation in a secure office setting would

have a different residual risk from that same workstation operating in a public environment.

- Working with an information systems security engineer, the customer will then select COTS/GOTS products providing the necessary strength and assurance.
- The system is evaluated and the residual risk is highlighted.

### 4.5.5.1 Example One

The following example uses an abbreviated description of the media protection portion of the IATF Remote Access (Section 6.2), Secret Dial-in Case, to demonstrate how the robustness strategy would typically be used in conjunction with other guidance sections of the IATF. No attempt was made to consider an actual customer's needs or an actual recommended solution.

In this example, the customer will be processing secret data at a continental United States (CONUS) site (perhaps in a work-at-home or temporary duty [TDY] situation) on a remote access dial-in system. The customer is required to protect this data and feels the threat to the data is primarily from adversaries with the following resource and risk-tolerance profile:

- Minimal resources at their disposal (i.e., they have enough money or contacts so that they can get someone to steal the laptop from a house or hotel room).
- Willing to take significant risk (i.e., if the person is caught stealing, the adversaries are willing to be prosecuted or know that if the thief gets caught the theft will not be traced back to them).

For this example, a media encryptor is recommended to ensure confidentiality of the customer's secret data on the hard drive of the remote computer. Because the data is secret, according to the current classification manual, compromise of that data would cause serious damage to the security of the United States. Based on the situation described here, the customer, in conjunction with the information systems security engineer, determines that the value of his or her information is at the V4 level (violation of the information protection policy would cause serious damage to the security, safety, financial posture, and/or infrastructure of the organization) and that the perceived threat is at the T3 level (adversary with minimal resources who is willing to take significant risk). According to the Degree of Robustness table, reproduced in Table 4-16, the minimum SML and EAL recommended is SML2 and EAL3 based on the threat and information levels.

**Table 4-16. Example Assessment Using Degree of Robustness Table**

Information Value	Threat Levels						
	T1	T2	T3	T4	T5	T6	T7
<b>V1</b>	SML1 EAL1	SML1 EAL1	SML1 EAL1	SML1 EAL2	SML1 EAL2	SML1 EAL2	SML1 EAL2
<b>V2</b>	SML1 EAL1	SML1 EAL1	SML1 EAL1	SML2 EAL2	SML2 EAL2	SML2 EAL3	SML2 EAL3
<b>V3</b>	SML1 EAL1	SML1 EAL2	SML1 EAL2	SML2 EAL3	SML2 EAL3	SML2 EAL4	SML2 EAL4
<b>V4</b>	SML2 EAL1	SML2 EAL2	<b>SML2</b> <b>EAL3</b>	SML3 EAL4	SML3 EAL5	SML3 EAL6	SML3 EAL6
<b>V5</b>	SML2 EAL1	SML2 EAL3	SML3 EAL4	SML3 EAL5	SML3 EAL6	SML3 EAL6	SML3 EAL7

For our example, the information systems security engineer and the customer, by applying the IATF guidance, determined that confidentiality and security management services are recommended. The user of the remote access dial-in system will want to keep the secret data on the laptop inaccessible while in storage. Not only must the data be encrypted on the media, but also the system must be operated in a secure manner; furthermore, the issue of recovering the data if it is compromised must be addressed. The systems security engineer and customer together decide that media encryption will be one mechanism used. Based on the discussions above, a media encryptor of strength SML2 should be considered.

Once the security service has been selected (confidentiality in, this case), the mechanism should be chosen from the columns of the table. In this case, the mechanism chosen is cryptographic algorithm. This mechanism was chosen because it was the cheapest, simplest, and most practical to implement. Physical security was not chosen because it was impossible to apply uniformly, in a timely manner, at different remote sites, without knowing all the sites in advance. Technical security was not chosen because of the wide variety of COTS laptops, which currently are not built with technical security countermeasures. According to the Confidentiality Mechanisms table, Table 4-17, the implementation should look for a cryptographic algorithm capability with an effective key length of 80+ bits, supported by a KMI/PKI providing the strength under category “Y,” as further described in Chapter 8-1, KMI/PKI.

**Table 4-17. Application of Confidentiality Mechanisms Table for Example One**

	Cryptographic Algorithm		Physical Security	Technical Security		Anonymity	
	Effective Key Length	Key Management		Antitamper	TEMPEST	TRANSEC	Cover
<b>SML1</b>	40+ bits symmetric key length, 80+ exponent 512+ modulus public key length	SMI Cat X, 80+ exponent 512+ modulus public key length, 80+ hash key length	Comparable to [7]	Level 1 or 2 [4]	Comply with applicable EMI/EMC FCC standards or portions of [8]	Low power unit	TBD
<b>SML2</b>	80+ bits symmetric key length, 160+ exponent 1024+ modulus public key length	SMI Cat, 160+ exponent 1024+ modulus public key length, 160+ hash key length	Comparable to [7]	Level 3 or 4 [4]	[8]	Commercial spread-spectrum signal techniques	TBD
<b>SML3</b>	Because of to the complicated nature of this level, a qualified information systems security engineer should be consulted. <sup>7</sup>	SMI Cat Z, also consult a qualified NSA information systems security engineer. <sup>7</sup>	Comparable to [7]	Level 4 or better [4]	[8]	Cryptographic spread-spectrum signal techniques	TBD

Because the remote access dial-in users will not have direct access to their system administrator or support services, the customer and the information systems security engineer found that the security management mechanisms of training and secure operations were of paramount importance and should be supplied at the SML3 level. Similarly, because of the “remote” use of the system, they thought that compromise might be more likely; and therefore, that the compromise recovery mechanism was also of paramount importance and should be addressed at the SML3 level. Further, because of the value of the information and the threat to the information, it was decided that the components should be characterized as methodically tested and checked, consistent with the Common Criteria EAL3. (Note that this depicts a situation in which the initial SML and EAL recommendations from the strategy were considered inadequate and were thus increased, presumably based on a detailed analysis of the situation.) Table 4-18 depicts how the Security Management Mechanisms table would typically be used.

Note that in using the tables in this section, not all columns must be used, and various SML levels may be employed as needed for the specific mechanism in question. In the media encryption example, it may be determined that security management mechanisms are of paramount importance; therefore, SML3 will be chosen for these mechanisms whereas confidentiality may be adequately provided with a SML2 cryptographic algorithm.

<sup>7</sup> DoD users should consult with a National Security Agency information systems security engineer. Other government users are directed to contact an information systems security engineer at the National Institute of Standards and Technology for guidance in this area. Nongovernment users should consult with a qualified ISSE, or equivalent representative within their organization.

**Table 4-18. Use of Security Management Mechanisms Table**

	<b>Compromise Recovery</b>	<b>System Administration</b>	<b>Training</b>	<b>OPSEC</b>	<b>Trusted Distribution</b>	<b>Secure Operations</b>	<b>Mechanism Management</b>
<b>SML1</b>	Informal plan	See Ch. 4, Countermeasures	Training available at user's discretion	Implementing OPSEC at user's discretion	Direct vendor purchase	Informal plan of operation	Procedural, at user's discretion
<b>SML2</b>	Detailed plan that is reviewed and approved	See Ch. 4, Countermeasures	Formal training plan	OPSEC training required, implementation at user's discretion	Certificate of authenticity, virus scan, validation	Formal plan of operation	Procedural, reminders, at user's discretion
<b>SML3</b>	Detailed plan that is reviewed and approved	See Ch. 4, Countermeasures	Knowledge/skill certification required	OPSEC training required; implementation required	Protective packaging, checksums, validation suite	Detailed, formal plan of operation	Automated support

### 4.5.5.2 Example Two

A second example of the use of the strategy is where a sensitive compartmented information facility (SCIF) is used for physical protection. Very different security mechanisms would probably be chosen to protect the information. If a DoD system is processing top secret data (V5), and the threat is very high (T6), one would normally apply rigorous SML and EAL levels. However, because the SCIF is used (and there is no connectivity outside the SCIF), the confidentiality requirement is mostly satisfied by physical security at the SML3 level. The access control requirement may also be satisfied by personnel security at the SML3 level. Any residual risk in the areas of confidentiality and access control may be mitigated by additional mechanisms at the SML1 level. This example shows the importance of layering security mechanisms to reduce risk.

### 4.5.5.3 Example Three

A third example involves a corporation with a large intranet that processes only unclassified data. The corporation has stringent legal requirements for protecting its data from unauthorized access or modification. It maintains a large, heterogeneous network with Internet access protected by firewalls. All data requiring legal protection is maintained in isolated subnets and is not available to authorized users via the network. Off-line stand-alone access is required to view the protected data. The security objective is to upgrade the network to allow the protected data to be securely accessible to all authorized users. Although the data being processed is unclassified, it must be protected from unauthorized access. Using the applicable CMM, a Capability Level 2 or equivalent is recommended. Taking all this into consideration, the customer and the systems security engineer determined that the information was at the V3 level (violation of the information protection policy would cause some damage to the security safety, financial posture, and/or infrastructure of the organization) and the perceived threat was at the T4

level (sophisticated hackers, international corporations). Using the Degree of Robustness table, reproduced in Table 4-19, the minimum SML and EAL recommended is SML2 and EAL3 based on the threat and information levels.

**Table 4-19. Example Assessment Using Degree of Robustness Table**

Information Value	Threat Levels						
	T1	T2	T3	T4	T5	T6	T7
V1	SML1 EAL1	SML1 EAL1	SML1 EAL1	SML1 EAL2	SML1 EAL2	SML1 EAL2	SML1 EAL2
V2	SML1 EAL1	SML1 EAL1	SML1 EAL1	SML2 EAL2	SML2 EAL2	SML2 EAL3	SML2 EAL3
V3	SML1 EAL1	SML1 EAL2	SML1 EAL2	SML2 EAL3	SML2 EAL3	SML2 EAL4	SML2 EAL4
V4	SML2 EAL1	SML2 EAL2	SML2 EAL3	SML3 EAL4	SML3 EAL5	SML3 EAL5	SML3 EAL6
V5	SML2 EAL2	SML2 EAL3	SML3 EAL4	SML3 EAL5	SML3 EAL6	SML3 EAL6	SML3 EAL7

In examining at the corporation's security objectives, the customer and systems security engineer determined that access control to the sensitive data and confidentiality of the data as it transits the intranet are the security services required. The mechanisms for implementation must operate on both Windows NT and HP UNIX platforms.

The confidentiality mechanisms for the SML2 category recommend a minimum 80+ bit symmetric key length, 160+ exponent 1024+ modulus public key length. The firewall key scheme includes ISAKMP/OAKLEY with DES or 3DES capability. 3DES is the scheme being evoked. The I&A mechanisms for the SML2 category recommend a system ID and a password with minimum character lengths. The corporation implements user IDs that are a minimum of six characters long and passwords with a minimum of eight characters, with an alphanumeric mix. However, because this was an internal intranet, no security services for integrity, availability, and nonrepudiation were considered necessary.

Each server requiring protection will have their own firewall installed, with the rules base requiring positive user identification and authentication before access is allowed. Initially, this process will be accomplished by using user IDs and passwords; however, it eventually will migrate to a PKI certificate-based capability. Confidentiality will be provided by the VPN capability resident to the firewall product. Client VPN software will be installed on each client machine enforcing the connection and VPN rules for the protected servers (if the client VPN is disabled, no connection is allowed to a protected server).



The following security mechanisms are employed.

- Fronting each server that contains protected data with a firewall.
- Invoking VPNs between client machines and the server and printers (using 3DES algorithm).
- Implementing user I&A using the VPN user ID and password.
- Implementing the firewall rule base to allow access only to users from authorized workstations.

Consideration was also being given to replacing the VPN-only client with a client that provides the VPN capability and extended the firewall policies to the user's desktop.

## 4.5.6 Robustness Strategy Evolution

Although robustness is now an inherent part of the IATF, it is a relatively new term in the IA lexicon and is not clearly seen as a unifying successor to a variety of similar existing concepts, such as completeness, assurance, and accreditation.

The security mechanism tables shown previously provide guidance at three strength levels to support a variety of security services. At another level of table refinement, security functions would appear, each of which would implement a particular mechanism. For example, each cryptographic algorithm would be a security function to implement a cryptographic algorithm mechanism in support of, for instance, a confidentiality security service. Many security functions implement each mechanism.

To compare and contrast these functions, there must be a way to cost the relative strengths. This effort would require development of cost metrics for each security service. Although functional specifications might be a relatively modest enhancement, the development of multiple costing schemes is likely to be a monumental effort. This level of refinement, which would enable uniform comparison of the protection provided by security mechanisms, is the goal of the strategy.

The IATF layered approach to security means that a variety of services and mechanisms might be needed to achieve the necessary protection. A broader view must be developed, looking across all needed services and the mechanisms proposed for providing those services. The residual risk to a system product must be addressed based on the environment in which it is implemented.

In addition to the above concerns, and because threat environments and security technologies are changing continually, the guidance provided is subject to frequent revision. To the extent possible, all mechanism recommendations should be by indirect references to formally endorsed documents. When this is not possible, periodic revision and trained ISSE application is the best way to ensure that guidance is current.

## 4.5.7 Real-World Applications

In the real world, it quickly becomes too complicated and impractical to determine layered solution approaches and describe, offer, support, and implement them for more than a small number of robustness levels. The threat levels and information value levels described previously simply yield too many combinations of SML and EAL levels, as shown in Table 4-7. The Office of Secretary of Defense (OSD) Information Assurance guidance and policy for DoD's Global Information Grid (GIG) divides robustness into three levels, a more practical approach.

The OSD GIG policy uses an implementation approach to robustness that draws conclusions based on real-world conditions (see Appendix E, OSD IA Policy Robustness Levels).

### 4.5.7.1 Future Work

The following areas need further attention:

- The network rating model/methodology also addresses “goodness.” How can that effort be incorporated into the strategy?
- Composition of metrics must be addressed in the framework of layered security.
- There is a need to ensure that the terminology used in the strategy is definitive and consistent with that used in the remainder of the IATF.
- The current approach to security is considered nonscalable, meaning that the process used for small systems may not be appropriate for large systems. This issue is also known as the composibility problem and the layering problem. How can the robustness strategy help address this issue?
- The mechanism tables must be reviewed for uniformity of detail and to identify nonquantifiable entries.
- The strategy must be updated to incorporate Common Criteria language throughout, rather than only in the description of the EALs.
- The effect of recommended robustness on return on investment to the customer must be considered.

## 4.6 Interoperability Framework

Users are becoming increasingly more dependent on information systems, creating a need for connectivity and interoperability at the application level. As information and telecommunications systems are introduced and updated, interoperability of these systems has become a major concern of the organizations that use them. When these systems must be secure, efficient interoperability becomes more difficult to achieve and manage. This section of the

IATF provides a high-level strategy for dealing with interoperability at the architecture and technology levels. Later releases of the IATF will address the issue of interoperability comprehensively, making users aware of options and trade-offs, and providing guidance on this important challenge.

## 4.6.1 Major Elements of Interoperability

This section identifies numerous elements that must be addressed to achieve interoperability. Typically, all of these elements must be addressed to achieve interoperability. The elements and the issues associated with them are discussed below.

- **Architecture.** A first step in achieving interoperability is an agreement on the nature of the security services, the type of security mechanisms to be used, and their allocation to functional components (e.g., enclave boundary interfaces, end-user terminals of the architecture, and the layers at which security mechanisms are applied).
- **Security Protocols.** Systems must use compatible communications protocols to achieve user-to-user connectivity. When this connectivity must be secure, several security elements associated with security protocols also must be considered. These elements include security services, cryptographic algorithms (with modes and bit lengths), synchronization techniques, and key exchange techniques. If options are permitted, common provisions are also needed for algorithm selection and broader security option negotiation. Typically, security protocol designers deal with these elements.
- **Product Compliance with Standards.** Another element needed for interoperability stems from the need to assure that products used to implement a network security solution actually comply with the standards they claim to support. There are a number of initiatives with the commercial sector and in Government that will verify compliance, as discussed in Section 4.6.3, Interoperability Strategy.
- **Interoperable KMI/PKI Support.** The services and techniques used to provide KMI/PKI constitute another element needed for interoperability. This element includes key and certificate formats, token mechanisms, cross certification (to facilitate communication across KMI/PKI security domains), directory systems, and compromise recovery capabilities. These considerations are discussed further in Section 4.7, Key Management Infrastructure/Public Key Infrastructure Considerations.
- **Security Policy Agreement.** Beyond all of the technical issues that must be addressed to allow interoperability, there is the fundamental need for organizational security policies that establish ground rules for permitting interoperability. The network or system owners must determine what minimum protection mechanisms and assurances (perhaps for particular types of data or destinations) are needed before they are willing to allow users from other networks or systems to communicate or interact with users of their resources and information. Because this important topic is beyond the scope of this document, it is assumed in the IATF that organizations wishing to interoperate have resolved any

incompatibilities in organizational security policy and that the only barriers are technical or economic.

## 4.6.2 Challenges for Interoperability

In formulating an IA solution, the following potential impediments tend to act as obstacles to achieving interoperability:

- Backward compatibility with legacy systems that do not use accepted standards and lack the negotiation mechanisms needed to interoperate with newer standards-based implementations (even if backward-compatible protocols and modes are available).
- Security solutions—lagging behind the rapid evolution of information technologies, often making security an adjunct capability.
- Evolution of standards or lack of standards accepted by either the user community or the commercial product marketplace.
- De facto proprietary standards or closed systems.
- Lack of an accepted source of testing to verify that products implementing standards do so correctly and that sufficient options from the standards are implemented to assure users that the resultant products are, in actuality, interoperable.

The challenge is to recognize and surmount these obstacles, yet still find a way to achieve the interoperability needed by our customers.

## 4.6.3 Interoperability Strategy

At this point in the IATF, it is appropriate to establish a basic, high-level strategy for dealing with interoperability. This strategy focuses on the following efforts.

- Fostering standards for secure applications and communications protection that are based on open architectures.
- Supporting security negotiation protocol standards that allow users to have varying policies and that provide a vehicle for negotiating elements of interoperability.
- Developing a strategy for migration from the interim solutions to open standards in environments where emerging technology dominates and users accept interim solutions that are not standards based.
- Defining initial interoperability standards, and influencing and migrating to a standards-based approach where gaps exist.

## UNCLASSIFIED

Technical Security Countermeasures  
IATF Release 3.1—September 2002

A major issue still remains. It is imperative to ensure that products and system components correctly implement these standards and options so that interoperability is actually realized. A number of initiatives within the Government and the private sector exist to address this issue.

These include the following:

- **Automotive Network eXchange® (ANX).** The automotive industry has recognized the importance of interoperability for the transmission of trading partner electronic information. The ANX network service is positioning itself to provide automotive trading partners with a single, secure network for electronic commerce and data transfer, replacing the complex, redundant, and costly multiple connections that exist throughout the automotive supply chain.
- **International Computer Security Association (ICSA).** The ICSA promotes the open exchange of information between security product developers and security service providers. ICSA acts as an independent third party that offers a number of initiatives, including a product certification program. ICSA certification develops criteria by which industry wide categories of products are tested. It certifies products on an annual basis and spot-checks for compliance throughout the year against the latest version of each product. Through use of this process, buyers of ICSA-certified products can be assured that they are getting the most secure products available at the time.
- **National Information Assurance Partnership (NIAP).** The NIAP is a joint industry-government initiative, led by the National Institute of Standards and Technology (NIST) and the National Security Agency (NSA) to establish commercial testing laboratories where industry product providers can have security products tested to verify their performance against vendor claims. As with the ICSA initiatives, a natural result of this testing will be user assurance that products advertising compliance with standards will indeed be interoperable.

These activities, and a number of others similar to them, will help product and system providers deliver solutions that support the interoperability needs of their broad customer base.

The interoperability strategy presented in this section is embodied throughout the IATF. In a later release of the IATF document, a more detailed treatment of specific issues affecting interoperability will be included in subsequent sections. Specifically, IATF Chapters 5 through 9 will include discussions of interoperability issues specific to each of the user requirement categories. These will include interoperability concerns or needs reflected in the captured requirements, technology assessments (to identify the degree to which the available solutions deal with interoperability issues), and recommendations (that deal with selection of architectures and protocols that achieve the needed interoperability). Chapter 8, Supporting Infrastructures will deal with interoperability issues associated with KMI/PKI.

## 4.7 Key Management Infrastructure/ Public Key Infrastructure Considerations

A KMI/PKI capability is needed to support most technical security countermeasures. This section provides a high-level discussion of the role of, and features associated with, a KMI/PKI. Detailed guidance on the architecture of KMI/PKI can be found in Chapter 8, Supporting Infrastructures.

### 4.7.1 KMI/PKI Overview

The KMI/PKI process generates, distributes, and manages security credentials. It can be considered as a set of interrelated activities providing security services that are needed to enable the framework's security solutions presented in IATF Chapters 5, 6, 7, and 9. KMI/PKI is a unique user requirement category in the IATF because it does not directly satisfy a user's security requirements; rather, it facilitates the use of security building blocks that are needed by other security mechanisms.

Current KMI/PKI implementations consist of numerous stovepipe infrastructures that support different user solutions. These are run by various organizations, even though the end user may need support from several stovepipe infrastructures for a single application. A complete system approach to any network security solution must include a KMI/PKI architecture that provides effective and efficient operations while maintaining the requisite security features and assurances.

A KMI/PKI architecture depends heavily on the specific applications it supports. For example, a VPN provides an encrypted pipe between two enclaves. The KMI/PKI provides keys and certificates to the cryptographic devices that provide authentication and encryption to establish and maintain the pipe. KMI/PKI could also provide additional services, including data recovery and a directory to provide access to users' public certificates.

A second way in which KMI/PKI differs from other solutions in the IATF is that its security is distributed through a number of separate elements. These elements require extensive security (e.g., encryption, certificate management, compromise recovery) among themselves to protect the user's key or certificate. Because of the serious repercussions of a successful attack against the KMI/PKI, internal infrastructure security requirements are often more stringent than is user services security. There are also unique requirements for the infrastructure (e.g., policy management), and the level of assurance for the KMI/PKI services is often higher.

## 4.7.2 KMI/PKI Operational Services

Four operational services are supported by the KMI/PKI. These services support different user applications and consequently employ different (but related) mechanisms and have unique security requirements. The first user service is symmetric key generation and distribution. This is still the primary key management mechanism within the classified community.

The second service, PKI, addresses both digital signature (for authentication and integrity) and key agreement with its associated certificate management. This is the primary key management mechanism within the commercial community.

The third service, directory service, is used to provide access to the public information required with PKI, such as the public certificate, the related infrastructure certificates, and the compromised-key information. Directory services can be provided either by a global set of distributed directories (e.g., X.509 Defense Message System [DMS] directories), or by an on-line repository at a single site. Although directories can be used for other things, they are normally very closely coupled with PKI.

The final service is managing the infrastructure itself. The distributed nature of the infrastructure places additional functional and procedural requirements on the KMI/PKI, and the sensitivity of the application imposes additional security requirements on the KMI/PKI. The internal structure of the infrastructure varies with the application it supports.

These services are discussed in greater detail in Section 8.1.

## 4.7.3 KMI/PKI Processes

KMI/PKI consists of a numerous processes that all must work together correctly for a user security service to be truly secure. Each of these processes is necessary at some level in all KMI/PKI architectures. The processes include the following:

- **Registration.** Enrolling those individuals who are authorized to use the KMI/PKI ..
- **Ordering.** Requesting the KMI/PKI to provide a user with either a key or a certificate.
- **Key Generation.** Generating the symmetric or asymmetric key by an infrastructure element.
- **Certificate Generation.** Binding the user information and the asymmetric key to a certificate.
- **Distribution.** Providing the keys and certificates to the user in a secure, authenticated manner.
- **Accounting.** Tracking the location and status of keys and certificates.

- **Compromise Recovery.** Removing invalid keys and certificates from the system in an authenticated manner.
- **Rekey.** Periodically replacing keys and certificates in a secure, authenticated manner.
- **Destruction.** Destroying the secret key when it is no longer valid.
- **Data Recovery.** Being able to recover encrypted information without direct access to the original key.
- **Administration.** Running the infrastructure.
- **Value-Added PKI Processes.** Supporting optional value-added processes, including archive, time stamp, and notary service (PKIs only).

The complete set of KMI/PKI processes is usually distributed to several elements performing independent tasks, requiring extensive coordination and security processing between elements. For most processes, there are numerous ways of implementing the services, based on the application supported, the security required, and the cost (e.g., money, people, and performance) the user is willing to pay. Each process contributes to the overall security of the KMI/PKI and is associated with various forms of attacks and countermeasures.



## UNCLASSIFIED

Technical Security Countermeasures  
IATF Release 3.1—September 2002

### References

1. Humphrey, Jeff and Gabrielson, Bruce “Phreakers, Trashers, and Hackers,” presented at AFSEA INFOSEC Engineering Course, 1995, Burke, VA.  
<http://blackmagic.com/ses/bruceg/hackers.html>
2. Reserved.
3. Coast Security Pages at <http://www.cs.purdue.edu/coast/intrusion-detection/>.
4. FIPS PUB 140-1, National Institute of Standards and Technology, Security Requirements for Cryptographic Modules, <http://www.itl.nist.gov/div897/pubs/fip140-1.htm>.
5. NSTISSI No. 4009, National INFOSEC Glossary.
6. Common Criteria for Information Technology Security Evaluation. CCIB-98 (ISO/IEC 15408), version 2.0, 1998, <http://csrc.nist.gov/cc/>.
7. DoD Reg. 5200.1-R, Information Security Program, 1997.
8. NSTISSAM TEMPEST/1-92 Compromising Emanations Laboratory Test Requirements Electromagnetics, 1992.
9. Laing, Alan “DoD PKI Level of Protection and The Appropriateness of Proposed Solutions for Various Applications” (Draft) 1998.
10. National Security Agency Specification for General Functional Security Requirements for a Telecommunications System (FSRS), 1989.
11. Information Systems Security Engineering Handbook, Release 1.0, 28 February 1994.
12. Security Management Infrastructure (SMI) Task 1 Team, Threat and Vulnerability Model for Information Security, 1997.

### Additional References

- a. NSA/CSS Dir. No. 120-1 NSA/CSS Operations Security Program, 1990.
- b. National Security Agency Specification for Unified INFOSEC Criteria, 1991.
- c. Ford, Warwick: *Computer Communications Security*, Englewood Cliffs, NJ: Prentice Hall PTR, 1994.

## Chapter 5

# Defend the Network and Infrastructure

---

Networks provide a transport mechanism for user traffic and for the availability of user information. Networks and their supporting infrastructures must protect against denial-of-service attacks that could prevent user information from being transmitted. The supporting infrastructure consists of the management systems and any other systems that support network operation.

The network supports three distinct types of traffic: user, control, and management. User traffic is simply the information that users are transmitting over the network. Networks have the responsibility to provide separation of user traffic. Isolation of individual user connections must be maintained to ensure reliable delivery of information. Additionally, confidentiality services *may* be provided by the network, either by government encryptors, for classified traffic, or through commercial encryption embedded in network components, for unclassified traffic.

Control traffic is any information transferred between network components that is necessary for establishing user connections. Control traffic provided by a signaling protocol, such as Signaling System 7 (SS7), includes addressing, routing information, and signaling. Proper addressing by the network infrastructure is essential for user traffic to be directed to the intended destination. Routing information must be protected to ensure that the user information will be properly transferred and that the path that user information takes is not manipulated. Similarly, signaling must be protected to ensure that user connections are established properly.

The third type of network traffic, management traffic, is any information that configures network components or information initiated from a network component that informs the network infrastructure on the status of the network component. Management protocols include Simple Network Management Protocol (SNMP), Common Management Information Protocol (CMIP), Hypertext Transfer Protocol (HTTP), rlogin and Telnet command line interfaces, or other proprietary management protocols. Network management traffic protection is essential to ensuring that network components are not modified by unauthorized users. If management of a network component is compromised, that component can be configured to perform any function the attacker wishes. Simply being able to view configuration information on a network component may give an attacker knowledge of network connections, addressing schemes, or other potentially sensitive information. Figure 5-1 illustrates the network and infrastructure in the high level Defense Information Infrastructure (DII) context. Some of the networks illustrated are controlled by government organizations, while others are controlled by commercial entities such as the public switched telephone network (PSTN) and the Internet.

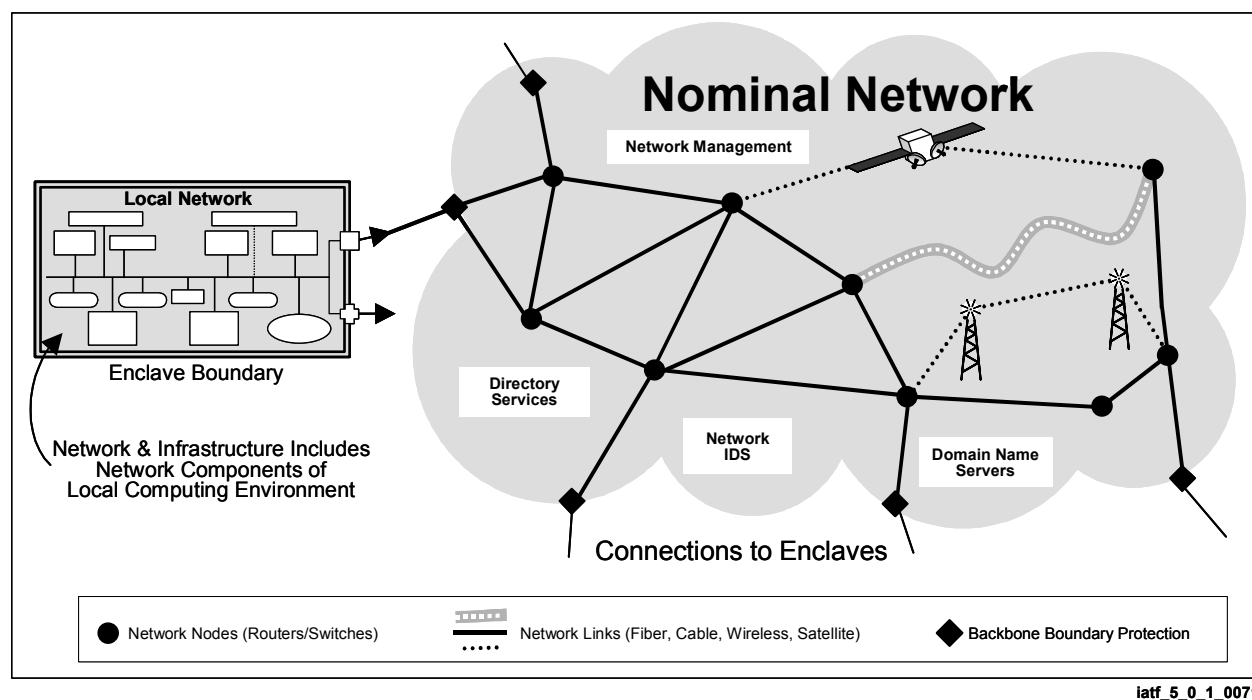

**Figure 5-1. Defend the Network and Infrastructure**

Today, commercial carriers provide over 95 percent of all the transmission service for all communications of the Federal Government and industry. In addition, most of the large civil government networks provided by General Services Administration (GSA), Federal Aviation Administration (FAA), Department of Transportation, etc., outsource the management of their networks. In light of this reliance on commercial control networks, all organizations should adopt a two-pronged approach—starting at the highest level—to defend their networks. First, organizations should ensure that they have established clear service level agreements (SLA) with their commercial carrier that specify metrics for reliability, priority, and access control. Commercial carriers view network security as a business issue. Therefore, they will not simply add security features. For them, a business case must be made; the customer must ask for these services. Second, organizations should recognize that during transmission, their data may be essentially unprotected. It is incumbent upon the *owner* of the information to implement security services, such as encryption for confidentiality, at the user level. Historically, few organizations outside of the Department of Defense (DoD) and the Intelligence Community (IC)—have developed strategies and encrypted data sent over commercial lines. In the past few years, however, services such as Pretty Good Privacy (PGP) have grown in use by government and industry organizations.

The general information assurance (IA) strategy for defending the network and infrastructure is to use approved wide area networks (WAN) to transport classified data among and between DoD and IC elements when feasible, and then to use National Security Agency (NSA)-approved—e.g., Type 1—encryptors, in-line network encryptors (INE), or traditional bulk encryptors to protect classified data transported over networks. To protect sensitive data exchanged among unclassified local area networks (LAN), the strategy is to use commercial

solutions that satisfy published criteria; are validated by an approved, independent laboratory; are properly configured; and are accredited for use by an approval process such as the DoD Information Technology Security Certification and Accreditation Process (DITSCAP).

For voice networks, a number of strategies are in use. DoD's protection strategy is to use approved common user networks when available, or NSA-approved subscriber voice terminals otherwise. The strategy for DoD tactical networks is to use NSA-approved tactical radios, tactical subscriber terminals, or INEs to protect classified information transmissions. Law enforcement organizations use encrypted communications in the field, generally following National Institute of Standards and Technology (NIST) Federal Information Processing Standards (FIPS) publications on encryption standards. Other civil agencies involved in tactical operations, such as responding to natural disasters, generally use commercial off-the-shelf (COTS) communications with no encryption. They are migrating to digital phones, which are less likely to be compromised. However, this move is motivated by market changes rather than any requirement to have more secure communications. The most critical requirements for emergency response functions are availability and reliability, not confidentiality.

To achieve interoperability between government and commercial networks, the strategy is to include denial-of-service protection measures in all SLAs for commercial leased network services. For DoD owned and operated networks, the strategy is to provide a number of measures to ensure network availability. These measures include mechanisms that ensure the positive control of network elements; Public Key Infrastructure (PKI)-enabled authentication and access control for remote management of all critical network elements; authentication and integrity protection for all network management transactions; and enclave boundary protection for centers that manage the control of DoD WANs.

The Defend the Network and Infrastructure chapter of the IATF consists of several sections. The Availability of Backbone Networks section considers data communications networks (e.g., Internet Protocol [IP] and asynchronous transfer mode [ATM]); and issues with secure network management. The Wireless section considers the security issues associated with cellular service, pagers, satellite systems, and wireless LANs. The System High Interconnections and Virtual Private Networks (VPN) section addresses secure connectivity between systems operating at the same sensitivity level via backbone networks. A future section dealing with secure voice transmission will cover voice over the PSTN, voice over Integrated Services Digital Network (ISDN), and voice over data networks. A future section on multiple security layers will address issues with using a single backbone to transmit information of the same classification level, but of varying compartments.

**UNCLASSIFIED**

Defend the Network and Infrastructure  
IATF Release 3.1 —September 2002

**This page intentionally left blank.**

## 5.1 Availability of Backbone Networks

Reliance on commercial providers of network services has been increasing, primarily owing to increased competition after the Telecommunications Act of 1996 and the exponential demand for bandwidth. While most private sector organizations traditionally relied on commercial providers for almost all of their network services, Government took a different view. Many government organizations, especially the Department of Defense (DoD) and the Intelligence Community (IC), held to the paradigm that they had to operate and maintain the entire communication system, including all of the long-haul communication transport systems.

With the move to more cost-effective commercial service providers, government organizations have had to join private sector organizations in seeking to influence the network security industry. The overall strategy for the public and private sector should be first, to educate—organizations should understand the different aspects of network security and determine their own requirements—and second, they should seek to participate in standards activities to influence standards, protocols, and operations.

This section of the framework focuses specifically on improving the availability<sup>1</sup> of the long-haul transport systems to meet the operational requirements even if the long-haul transport systems are under an information warfare attack.

### 5.1.1 Target Environment

This section of the framework focuses on backbone networks (BN). The most common examples of a commercial BN are the terrestrial-based voice systems and the Internet. In the DoD, the most common data BN is the Defense Information Systems Network (DISN). The framework looks to encompass a wider range of systems than data wide area networks (WAN) (including wireless systems, satellite systems, video teleconferencing systems, and voice systems). BNs hereafter refer to this entire range of communication systems.

Typically, BNs are known by a single name, such as the Internet or the DISN. However, these networks are constructed of a range of technologies and transport systems. Although the separations between BNs and other parts of the communication systems are neither simple nor clean, useful characteristics can be described in terms of a generalized model of a BN. We can decompose our model of the BN into nine focus areas:

- Network-to-network communication.
- Device-to-device communication.
- Device management and maintenance.
- User data interface.
- Remote operator-to-Network Management Center (NMC) communication.

---

<sup>1</sup> The backbone security service is limited to availability for two reasons. First, backbones may be acquired through commercial service provisioning thus restricting the acquisition office from dictating special security services. Second, the communication models used in today's systems dictate the other security services, such as confidentiality and data integrity, to be handled by the end system and not the backbone network.

## UNCLASSIFIED

Availability of Backbone Networks  
IATF Release 3.1—September 2002

- NMC-to-device communication.
- NMC enclave.
- Vendor deliveries and maintenance.
- Vendor design and manufacture.

The availability of a BN is closely connected to the communications between networks, network devices such as routers and switches, and the network management's centers and the devices they manage. Additionally, the NMCs and network devices must be protected. We performed an Information Systems Security (INFOSEC) Information System Security Engineering (ISSE) analysis of the model components for five network cases. The remainder of this section presents the backbone availability model and security issues related to the analysis.

The following provides an expanded description of the nine backbone availability model components identified in the model depicted in Figure 5.1-1.

- 1) Network-to-Network Communication.** There are two classes of network traffic or data of concern here. One data class is the user traffic or user data that traverses this interface. The other data class, control traffic, is the communications required between the backbone transport devices and the external network devices. It is necessary to distinguish between two classes. Typically, the device-to-device communication is a well-defined protocol providing network-specific data necessary to transport the user data. The user data will be entering and exiting the backbone transport network. This is one of the BN boundary interfaces that allows the ISSE to define the inside and the outside of the BN.
- 2) Device-to-Device Communication.** This area considers the internal communications between devices that are components of the BN itself. Generally, BNs require continual information exchange of this management and control traffic among devices to provide optimum performance and to support on-line maintenance and troubleshooting.
- 3) Device Management and Maintenance.** This area focuses on configuration and parameter adjustments required to maintain the individual devices on the BN, the network management traffic. Typically, each device has a unique set of operational requirements and specifications that must be controlled by the NMC or maintenance personnel for that device to remain an active node on the network.
- 4) User Data Interface.** The user data interface is the means by which user data enters and exits the BN. This may occur at any connection supporting user connectivity including user networks represented by the Local Subscriber Environment (LSE) and other networks connected to user networks represented by the external network. These interfaces should be resistant to cyber attacks from the user connections.

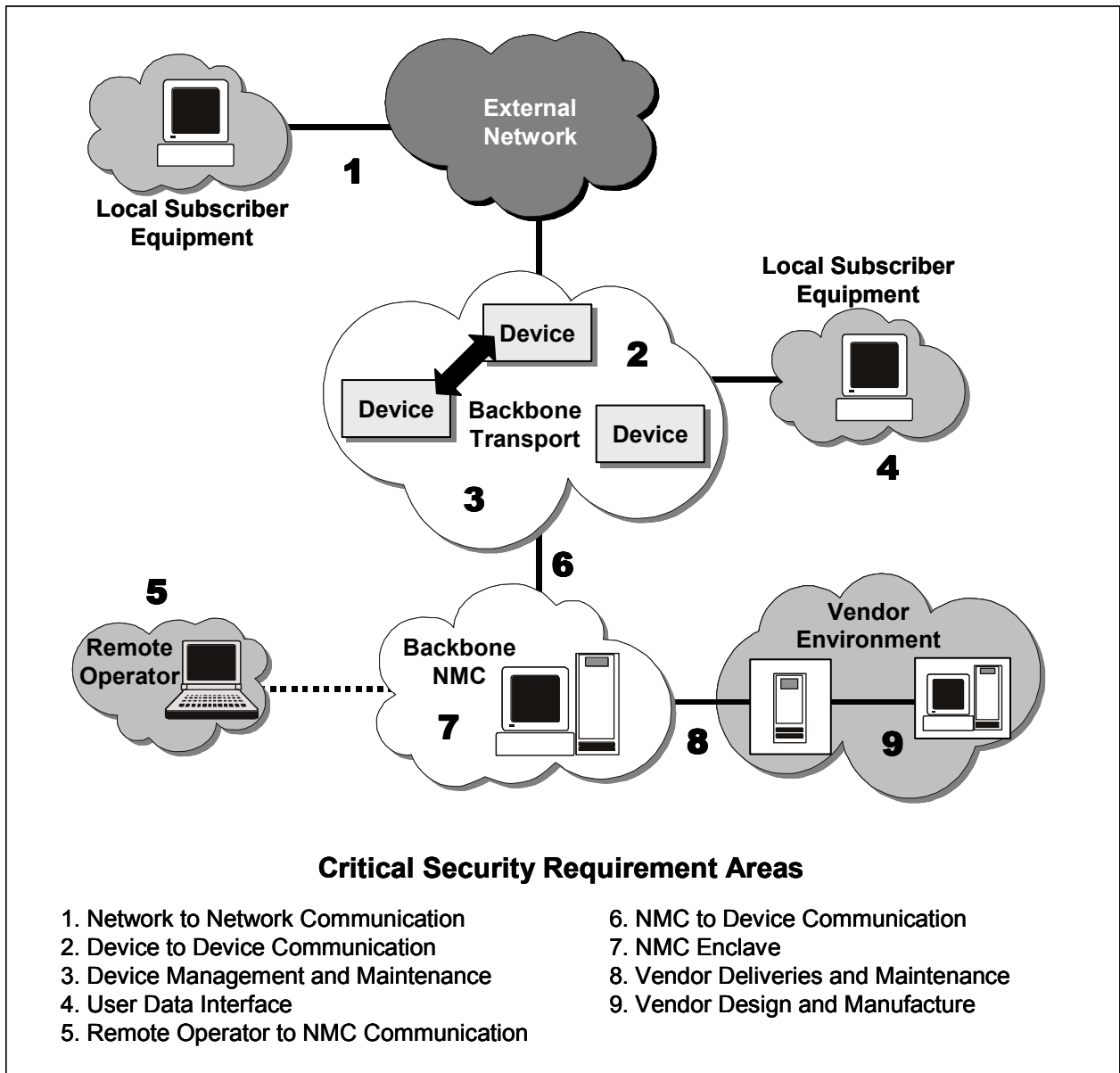

iatf\_5\_1\_1\_0011

Figure 5.1-1. Backbone Availability Model

- 5) **Remote Operator-to-NMC Communication.** The primary concern with this area is the operator's physical security, e.g., where the equipment, usually a laptop computer, is being used, and what protection is afforded to the equipment. In addition to those security concerns, there is the connection into the NMC and the type of security needed to protect it. When this area is needed to support operational requirements, it increases the complexity of analyzing the NMC, so perimeter security considerations regarding access to the NMC should be analyzed.
- 6) **NMC-to-Device Communication.** Addressing this area allows analysis of the perimeters of the backbone transport and the NMC, recognizing the NMC requires



## UNCLASSIFIED

connectivity to the devices making up the backbone transport for all of the management operations. The connectivity may occur through in-band or out-of-band signaling using either primary or secondary channels. This provides opportunity to access the BN devices, and the NMC equipment and data, plus it exposes network management data.

- 7) **NMC Enclave.** The concern in this area stems from the concept that network management is critically important to the availability of the BN and should be operated separately from, what has been called in this section, user data. The management equipment and data require security protection from attack so they may successfully perform their mission, which is to manage the BN. Considering this as a local network environment will permit the ISSEs to take full advantage of virtually every other section of this framework document.
- 8) **Vendor Deliveries and Maintenance.** This area is more complex than Figure 5.1-1 depicts. The NMC may receive equipment or software to be prepared for installation in the backbone transport. It is possible that the vendor will be called on to provide product service and maintenance directly to the backbone transport devices. The NMC may receive the information from the vendor either indirectly, e.g., by the postal system, or directly on line through a network connection. The ability to ensure the validity of the information and equipment received plays an important role in the availability of the BN.
- 9) **Vendor Design and Manufacture.** This area covers the entire manufacturing process from development to production to delivery of the end item, whether it is a device or software. Security must be applied over all of this so that what “comes out of the box” can be trusted to operate properly. Security must also be designed into the product so that many of the security requirements raised in the other eight areas can be achieved.

Now that the BN focus areas have been described, it is useful to return and discuss its generalized use and operations. One of the general characteristics of the BN is that it has an inside and an outside. The user community generally connects from outside of the *backbone transport* portion of the BN. All internal connections are either between internal parts of the backbone transport or with the *backbone NMC*. By extension, the NMC is considered to be inside the BN. In today’s environment of searching for cost reduction while improving user services, a BN will likely interoperate with one or more *external networks* in addition to the user community it supports. The external networks are typically deemed untrustworthy with respect to the BN being analyzed.

Another characteristic of a BN is that it is viewed by users as a means to an end for their missions. The user’s requirement is normally to communicate with another entity, not the BN itself. In other words, the user information travels across the backbone but does not stop there. In Figure 5.1-1, the users are represented by the LSE clouds. The security concerns of the LSE are addressed elsewhere in this framework, e.g., Chapter 6, Defend the Enclave Boundary/External Connections.

In this model, the backbone transport devices are managed and operated remotely by the NMC using commercial off-the-shelf (COTS) or government off-the-shelf (GOTS) network management systems. The NMC devices are separate and distinct from the backbone transport devices. It should be noted that the NMC component of the BN architecture is fundamentally the same as an LSE. Though the purpose and function may be different, the NMC architecture takes advantage of the appropriate security guidance provided throughout the rest of this document.

Generally, the NMC must be operational 24 by 7 (24 hours a day, 7 days a week). Because of that need, NMCs may support remote operator connectivity, represented in Figure 5.1-1 by the remote operator. It is common practice to provide remote access to system experts so they do not have to be physically present at the NMC at all times. A remote operator is similar to a generic remote user and some of the security considerations are the same. Please refer to Section 6.2, Remote Access. However, a remote operator has a significant difference. A remote user connects into the backbone network either from a special service provision—e.g., roaming user dial-up service—or from some external network or LSE connection. The remote user is considered to be *outside* the BN. In contrast, a remote operator—who connects into the backbone NMC via a similar manner—is considered to be *inside* the BN.

In the full life cycle of a BN, new capabilities and features are constantly being incorporated into the devices that compose it. Occasionally new devices or components are installed to replace or upgrade the existing devices or to expand the network and its capabilities. The security concerns associated with this evolution are represented in Figure 5.1-1 by the vendor environment and interface. A common practice in the network industry is to develop the devices and the product software/firmware and then ship these new components to the field in the same manner used by any computer-based product. One method that is often used is to post the product software on an Internet Web site for customer downloading. This distribution approach is open to compromise. To maximize the availability of the BN, it is necessary to have trust (in a security sense) in the entire life-cycle process of the BN and its components.

## 5.1.2 Consolidated Requirements

The fundamental requirement for availability of BNs is that they are required to be present and functioning properly when the missions require them. The President's Commission on Critical Infrastructure Protection acknowledges the importance of solving this problem with the following: "The critical infrastructures [including Information and Communications Industries] are central to our national defense and our economic power, and we must lay the foundations for their future security ..." [1] Specific requirements are identified below.

### Functional Requirements

- BNs must provide an agreed level of responsiveness, continuity of service and resistance to accidental or intentional corruption of the communications service. (The agreement is between the owners of the network and the users of the network.)

## UNCLASSIFIED

Availability of Backbone Networks  
IATF Release 3.1—September 2002

- BNs are not required to provide security services of user data (such as confidentiality and integrity)—that is the user's responsibility.
- BNs must protect against the delay, misdelivery, or nondelivery of otherwise adequately protected information.
- BNs, as a part of the end-to-end information transfer system, must provide the service transparently to the user.
- As part of the transparency requirement, the BN must operate seamlessly with other backbones and local networks.

### 5.1.2.1 Security Requirements

#### Access Control

- Access controls must be used to differentiate access to the network devices between users' access for transport of data and administrator access for network management and control. For example, access controls must enforce user's access to status information versus configuration information.
- Access controls must limit access to the NMC.

#### Authentication

- Network devices must authenticate the source of all communications from other network devices, such as routing messages.
- Network devices must authenticate all connection requests from network management personnel.
- Network management systems must authenticate network management personnel prior to being granted access.
- The NMC must authenticate the source of all communications entering the NMC from external networks.
- The NMC must authenticate the source of vendor-supplied material.
- The NMC must authenticate the source of vendor-supplied software. For example, new releases of operating systems must be authenticated prior to being implemented across the network.
- The NMC must authenticate all dial-in users prior to granting them access to the NMC.

## Availability

- Hardware and software resources (such as user agents and servers) must be available to users.
- The service provider must provide a high grade of system availability for users.

## Confidentiality

- The confidentiality of key material must be protected.
- The network management system shall provide confidentiality of routing information, signaling information, and network management traffic to provide traffic flow security.

## Integrity

- The integrity of communications between network devices must be protected.
- The integrity of the hardware and software in network devices must be protected.
- The integrity of communications between network devices and the NMC must be protected.
- The integrity of vendor-supplied hardware and software must be protected.
- The integrity of dial-in communications to the NMC must be protected.

## Nonrepudiation

- Network personnel must not be able to repudiate changes to the configuration of network devices.
- Vendors must not be able to repudiate vendor supplied or developed hardware or software.

### 5.1.2.2 Networking Environments

Please refer to Section 5.3, System High Interconnections and Virtual Private Networks (VPN) of the framework, where these requirements have been addressed in detail.

### 5.1.2.3 Interoperability Requirements

BNs must be able to securely interoperate with other BNs and local subscriber environments. This requirement includes the secure exchange of network management information and routing data.

## 5.1.3 Potential Attacks and Potential Countermeasures

As with the Requirements for Network Environments section above, please refer to the corresponding System High Interconnections and VPNs, Potential Attacks, Section 5.3, for substantial, related material. The reader should note that this section has a somewhat different focus from that of Section 5.3. This section is focused on attacks against network management operations and against BN infrastructure devices. In addition, this section focuses specifically on user data and information in terms of availability and delivery service capability in the presence of the attacks discussed below.

Threats to network availability can be grouped into three general threat categories as discussed below.

- **Loss of Available Bandwidth.** The threat category occurs because every network has a limited amount of network bandwidth. Attacks can reduce the amount of available bandwidth, limit network resources for legitimate users, and decrease the network's availability. These attacks generally do not impact the operational control of the network. The network is operating as designed and the NMC retains control over the network infrastructure. This category applies to model components 1, 2, 4, and 6 in Figure 5.1-1.
- **Disruption of Network Management Communications.** This threat category impacts the normal operation of the network. Intrinsicly, every network must move information from one user to another over network communication channels. Attacks in this category threaten the normal flow of information through the network by disrupting the communication channels. Examples include shutting down circuits or providing erroneous routing information. These attacks focus on the network management traffic used to control the flow of information across the network. The network is not operating as expected due to the misdirection of the flow of information, but the NMC still has some control over the infrastructure. This category applies to model components 1, 2, and 6 in Figure 5.1-1.
- **Loss of Network Infrastructure Control.** This threat category is the most severe. These attacks represent a loss of control over the network infrastructure. Once the network managers have lost control over the network infrastructure, or over the NMC, they are no longer able to provide the intended network services and, in fact, the network assets are conceivably at risk of being used to support the attacker's goals. This category applies to Critical Security Requirement Areas (CSRA) 3, 7, and 9 in Figure 5.1-1, in terms of loss of control of the BN. The attacks may also occur via any of the other model components in Figure 5.1-1.

Each threat category represents a potential loss of network availability. However, the severity of the attack is related to the loss of control of the network, since control represents the ability of the network managers to respond to an attack. These categories are then considered within the

context of the major threat categories discussed in Chapter 4, Technical Principles, of the framework.

The remainder of this section discusses the relationship of these three general threat categories and the classes of attacks described in Section 4.2, Adversaries, Threats, (Motivations/Capabilities), and Attacks. Where appropriate, countermeasures for specific attacks are highlighted below. The countermeasures are consolidated in the section that follows.

### 5.1.3.1 Passive Attacks

Passive attacks monitor and collect information as they traverse the network. Previously, BN providers did not consider the passive intercept of network management data as a threat to the network except as a means of gathering information for a more serious active attack. An example was intercepting fixed identifications (ID) and passwords to support a subsequent attack on the control of the network infrastructure. Now, BN providers are viewing passive attacks with growing concern. Providers are considering the overall network topology as sensitive information, with its protection from passive attacks needed to mitigate potential disruption of network management communications.

It remains to be seen which way the commands, status, and the rest of the network infrastructure management traffic will be viewed in the future, but it seems BN providers are working hard to improve security. This is demonstrated prominently in the latest release of the Simple Network Management Protocol version 3 (SNMP v3), which has significant security section additions over earlier versions of SNMP. This class applies to model components 1, 2, 4, 5, and 6 in Figure 5.1-1.

### 5.1.3.2 Active Attacks

Active attacks represent the classic attack by an outsider<sup>2</sup> on the network. In the case of the backbone availability model, the outsider is represented by a “user of the network” or by an adversary connected through an external network connection (as opposed to the insider who is the manager or administrator of the network). All three general threat categories identified above in Section 5.1.3, Potential Attacks and Potential Countermeasures, can be realized; the following discusses the general threat categories relative to this class. These attacks apply to model components 1, 2, 4, 5, and 6 in Figure 5.1-1.

**Loss of Available Bandwidth Attacks.** Network bandwidth represents the network’s ability to transfer information. Loss of available bandwidth attacks (the first general attack category discussed above) consumes network bandwidth, preventing legitimate network users from exchanging information. Three common available bandwidth attacks are the following.

---

<sup>2</sup> Note that the Availability of Backbone Networks section of the framework views insiders and outsiders from the view of backbone networks. Thus, insiders are those authorized to control and manage the network; outsiders include both authorized users of the network (who do not have privileges to effect the control of the network) and potential adversaries that do not have authorized access.

## UNCLASSIFIED

- 1) Jamming attacks are usually the easiest to detect and possibly the hardest to counter for a network backbone. For example, in a jamming attack an adversary transmits noise in the electromagnetic spectrum of the network preventing the flow of information. Two examples are between a satellite and a ground station or between cells of a wireless network.

A variety of countermeasures—e.g., frequency hopping and redundancy via an alternative media such as terrestrial-based hard-wired systems—for these attacks have been developed for military applications. These countermeasures are usually not implemented in commercial backbone BNs because of cost and other constraints. These attacks apply to model components 1, 2, 4, and possibly 6 in Figure 5.1-1.

- 2) Flooding attacks consume network bandwidth by “burying” the network with processing communications in excess of network capability. Everyone is familiar with the problems with the phone system over holidays or during disasters where everybody tries to use the limited resource at the same time. Active cyber flooding attacks produce the same result using spurious communications traffic. This attack is difficult to counter since the network managers can rarely distinguish legitimate traffic from spurious traffic. The two most common countermeasures are to support a preemption capability, which allows specified users the right to specific bandwidth regardless of other demands on the system, or to limit the bandwidth available through any access point onto the network. This attack is typically applied at model components 1, 2, and 4 in Figure 5.1-1.
- 3) Theft of service attacks may be the subtlest of the available bandwidth attacks. These attacks consume bandwidth, but they appear as normal operations. Attackers pose as legitimate users, establish a connection, and use the network to transfer their information. Most of the time, network managers do not realize bandwidth is being stolen until valid users receive their bill and claim that they did not make specific calls.

A typical countermeasure is to require the users to authenticate themselves to the network before being granted access to network services. Another countermeasure relies on audit techniques. For example, the system could maintain a profile of users’ normal activities and trigger an alarm when the network detects abnormal activity. This attack applies to model components 1 and 4 in Figure 5.1-1. It is also possible at model components 2 and 6.

**Disruption of Network Management Communications Attacks.** These are active attacks that disrupt network communications, intending to interfere with the flow of information across the network by attacking the control commands to the infrastructure devices. By way of contrast, bandwidth availability attacks do not impact the normal operation of the network. They consume bandwidth, limiting the availability of the network but not modifying the command and operation of the infrastructure devices. Network managers are still able to control the network, but the network is receiving misinformation causing a disruption in service. For example, Internet Protocol (IP) routing networks pass network topology data between the routers. This data allows the routers to move a user’s information across the network. If this data is modified,

the routers no longer deliver the user's information as expected, reducing the availability of the network.

Attacks in this category are specific to the BN and how it establishes and maintains the communication pathways to transfer a user's data. For example, voice networks rely on Signaling System 7 (SS7) to manage voice circuits. An attack on this network is to insert a message signaling "one of the users hanging up the phone" resulting in the circuit being dropped. Asynchronous transfer mode (ATM) networks establish virtual circuits to transfer a user's data. An example of a disruption attack on an ATM network would be to transmit an operations, administration, and maintenance (OA&M) cell telling a switch to shut down the virtual circuit. Analysis of this area of attack considers model components 1, 2, 4, 5, and 6 in Figure 5.1-1.

Two countermeasures are available to protect against disruption attacks. First, all network management traffic should originate within the network. This countermeasure requires the network edge devices to check all traffic entering the network to ensure that no network management traffic enters the network from the outside. This approach is referred to as establishing a security perimeter, an enclave boundary, on the system. Second, the integrity and the authenticity of network management traffic should be verified. For instance, a digital signature could be incorporated into the network management traffic. This mechanism could also be used to protect against a replay of valid network management traffic with the incorporation of time stamps or sequence numbers into the signed network management traffic.

**Loss of Network Infrastructure Control Attacks.** The most severe attacks are those against the network operators' control of the network infrastructure. Three ways of attacking control of the network infrastructure are the following.

- 1) Network control attacks directed at the communications between the network operators and the network devices.** These attacks seek to isolate the network operators from the network devices. For example, network operators may access their network through a single connection point into the network. If this point is compromised the network operators cannot access the network.

The best countermeasure is to provide redundant access to the network, allowing the free flow of information from the network managers and their devices. This countermeasure has implications later in this discussion for another control attack.

- 2) Network control attacks directed at network devices.** These attacks focus on getting access to, and thereby control of, the device. For example, most network managers remotely manage their devices and use Telnet or other communications protocols to log into the device. Once the network operator has access, the device can be re-configured, including changing the password used to log into the device. An adversary may choose several ways to gain this control. One example is for an adversary to actively attack the access control using password-sniffing programs. Two possible countermeasures for this attack are to strongly authenticate network management requests prior to granting them access to the device or to set up a protected channel, such as an encrypted VPN, between the network operator management station and the device.



- 3) **Network control attacks directed at the NMC.** If the NMC is rendered inoperable, the network operators are unable to access, let alone manage the network. Every communications path into the NMC serves as a potential attack path. Viruses are an example of these attacks. Viruses could destroy the contents of the memory of the network management devices. Several types of countermeasures are available to protect the NMCs against these attacks. Network guards or firewalls can be used to monitor the communications entering the NMC. These devices can prevent unauthorized communications and check incoming traffic for viruses and other threats to the NMC. A second type of countermeasures is procedural. Policies and procedures should be implemented to support the restoration of the NMC or establishment of redundant NMCs.

### 5.1.3.3 Insider Attacks

The insider threat considers an insider to be any user or network management operator of the system who knowingly or unknowingly causes the reduction of the availability of the BN. Insider attacks are initiated by personnel responsible for managing the network. The majority of these personnel are located in the NMC. In the analysis of BNs there are two “insiders.” There are the operators of the network represented in the model by the backbone NMC. The model recognizes a special case of management personnel: the personnel that operate remotely from the NMC and require additional scrutiny. There are also the developers and producers of the network components, represented in the model by the vendor design and manufacture. Specific insider attacks relevant to BN availability include the following.

- Backbone NMC insider has direct access to the NMC management assets. These users have legitimate reasons for accessing and configuring network assets. These users have the ability to launch subtle attacks on the network, by supplying misinformation to the network assets, or blatant attacks by transferring control of the network assets to an outsider.
- The most effective countermeasures rely on strong procedural mechanisms and strong accountability. Procedural mechanisms can be implemented to separate critical network functions, such as the configuration, maintenance, and provisioning of network assets from noncritical functions, e.g., general e-mail and Web-surfing. Audit mechanisms can be implemented to review the execution of network operations.
- Remote operators are a special case of the backbone NMC insider. These operators are generally on-call experts who help troubleshoot network problems. These operators pose as big a threat as the normal backbone insider does, but their identity cannot be confirmed by procedural mechanisms, and their commands can be compromised during transmission.
- A common countermeasure is to employ a secure modem to protect the remote operator’s dial-up connection. Regardless of the type of remote connection, the identity of the remote operator should be authenticated and the integrity of the transmitted data protected. Analysis of this area of attack considers CSRA 5 in Figure 5.1-1.

- Vendors and producers that develop software control many if not all of these devices. Commercial software is not typically developed with the strict configuration control that is associated with the development of trusted software. Therefore, there is a potential that malicious code can be embedded in the software. This code can support a range of attacks on the network infrastructure including the destruction of the system configuration information, the generation of spurious command information, and the loss of control of the network devices. This threat recognizes the malicious intent of the code inserted into the operating system; another aspect that must be considered is development software that could be exploited. Software developers are infamous for inserting “backdoors” and other features that allow to easy access to the system they are working on. If these undocumented features are not removed before the software is released, they could be exploited by an outsider to gain control of the system.
- The most effective countermeasures to this threat are procedural mechanisms. These mechanisms include the implementation of a strong software engineering process, which identifies the requirements for every software module and reviews the implementation, and strong configuration management. Analysis of this area of attack considers model component 9 in Figure 5.1-1.

### 5.1.3.4 Distribution Attacks

Distribution attacks alter the hardware and software provided by the vendors (commercial or government) as the mechanism to attack the network. These attacks are not limited to the vendor’s personnel, but include the delivery cycle as the hardware and software moves from the vendor to the NMC. The distribution threat needs to consider the movement of new software releases from the vendor to the installation in the network backbone. A common distribution mechanism is to provide a Web server that users access to download the new releases. Currently, users cannot distinguish legitimate material from modified material.

An effective countermeasure is to apply digital signatures to the material allowing the network managers to verify the integrity and authenticity of the information. Analysis of this area of attack considers model component 8 in Figure 5.1-1.

## 5.1.4 Technology Assessment

BNs are not limited to a single technology. Typically, a BN is constructed using a variety of technologies. For instance, the DISN uses IP routers to connect subscribers to the BN. Connectivity between routers is provided by commercial leased lines, satellite links, or ATM switches. This section assesses each of the common technologies used to construct a BN and addresses the available security features.

The technology assessment cannot be limited to the routers and switches used to pass data across the network; it also needs to look at the technologies used to manage the networks. In some instances, a single technology or technique can be used for a number of different types of devices, such as SNMP or Telnet. Alternatively, a single or proprietary protocol may be used to

manage the network devices. This section looks at the security features in network management protocols for Data Networks-IP Router Networks. Later releases of the framework will look at the security features of Multimedia networks and ATM networks.

### **5.1.4.1 Data Networks IP Router Networks**

IP networks are prevalent in today's commercial and government environments. IP network devices used in the wide-area infrastructure must have security features which promote a more robust and secure environment. IP is a connectionless packet oriented protocol that requires security considerations that are different than other technologies used for WANs. IP is a shared media so information that is addressed to a particular destination is readable by multiple network elements. Connections between peers may traverse multiple nodes or hops in the network. For security, this means that a network element does not know its immediate neighbors. Security services, i.e., authentication, access control; must be performed on a per packet basis, because a packet received on a port of an IP router may have originated almost anywhere in the network. Additionally, because IP packets are variable in length, security relevant information may be included with each IP packet.

#### **IP Transactions**

There is network control and management traffic within wide-area IP networks that is required for the BN to function properly. Through the manipulation of these communications, an attacker may modify the operation of the network to accomplish his goals. Because IP is a very dynamic environment, packets may be misdirected, directed through specific routers, or service may be selectively or globally denied. The following sections describe the IP network communications that require security enhancements and which security services can provide protection.

#### **Domain Name Server**

IP networks are dependent upon translating high-level domain names to IP addresses. This service is dependent upon the information stored on local and regional Domain Name Servers (DNS) to be accurate. Without accurate translation between domain names and IP addresses, IP packets cannot be properly routed through the network. Connections will either not be established, or established to end systems other than the intended end systems. The DNS query contains address information that must be translated as well as the responses to previous translation requests.

The integrity of this transaction is essential to establishing communications with the intended end system. The information on the DNS server, as well as the DNS query must not be modified by an unauthorized operator. One of the basic design philosophies of DNS is that DNS information is public and should be provided to all inquirers. Therefore there should be no attempt to implement an access control policy for DNS. Authentication and integrity are critical for an inquirer to know that they have contacted an authorized DNS server, and that the information retrieved from the DNS server is accurate.

## Internet Control Message Protocol

To report errors and unexpected error conditions, or to support network functionality, Internet Control Message Protocol (ICMP) is included with all IP implementations. ICMP poses several unique problems. ICMP messages may be viewed by any node within the network, and it is local policy for each node to act or not act on an ICMP message that it has seen. Additionally, ICMP is an IP layer protocol and does not ride on top of Transmission Control Protocol (TCP) or User Datagram Protocol (UDP). ICMP messages terminate directly at the operating system kernel and are not passed up the protocol stack.

ICMP messages should not be encrypted because all nodes in the network must be able to view them. ICMP messages must only be acted upon when they are received from an authenticated source. Additionally, ICMP messages must also pass an integrity check, to verify that they have arrived as intended. However, there are no security solutions implemented or under development to solve the problem of unauthorized ICMP messages. The recommended approach for local enclaves is to filter on ICMP messages and to only allow those ICMP messages that are critical to operations. This approach does not eliminate the risk of ICMP unauthorized ICMP messages, but it does reduce the risk. In WANs this approach is not viable. The WAN may need to transport ICMP messages between enclaves. To meet customer requirements for supporting network services, filtering on ICMP messages is not an option.

## Routing Messages

An essential part of any IP network, is a dynamic routing mechanism to efficiently transfer packets through out the network. The accuracy of these routing messages as well as the routing tables stored on routers is essential. This accuracy ensures that the routes that the connections take through the network are not denied and make effective use of network resources. Protecting a router's routing table is critical to preserving the availability of the network.

Integrity mechanisms are required for the routing updates sent between routers. This will ensure that routing updates are not modified as they travel through the network. Internal to the routers, an integrity mechanism is also required. Routing tables must be protected against unauthorized modification to ensure that they contain an accurate representation of the network. Additionally, an authentication mechanism is required to ensure that routing updates are not being injected into the network from an unauthorized source.

## Boot Protocol/Dynamic Host Control Protocol

The Boot Protocol (BOOTP) protocol is used when a network device powers up and needs to determine its IP address and possibly its hardware address. If a BOOTP message is intercepted en route to the BOOTP server, an attacker may respond with their own reply. This may cause the network device to download the incorrect memory image, which could have improper configuration information. The Dynamic Host Control Protocol (DHCP) extends this capability to allow dynamic IP addressing. Addresses of other necessary network elements, i.e., location of DNS server, location of timeserver; may be contained in a reply to a DHCP request.

## UNCLASSIFIED

Availability of Backbone Networks  
IATF Release 3.1—September 2002

The security services required to protect BOOTP and DHCP messages are authentication and integrity. Integrity ensures that BOOTP and DHCP replies are not modified while traversing the network. It is also important for the BOOTP/DHCP server to authenticate itself to the network device to ensure that an attacker is not masquerading as the BOOTP/DHCP server. Configuration information received in a BOOTP/DHCP response must be received from an authorized server.

## Network Management

Perhaps the most critical area for WAN availability is network management. IP devices must be configured properly and must be resistant to malicious or unintentional tampering in order to provide network services. There are several physically different methods of managing an IP device. These are:

- **Inband.** Network manager connects to the network device using the same communication channels used for user traffic. The protocols used for this may be SNMP, Telnet, or HyperText Transfer Protocol (HTTP) for Web based management.
- **Ethernet Port.** Network managers connect to the network device using an Ethernet network physically separated from the network used for user traffic. This requires an additional network infrastructure to support management traffic. The protocol used for this may be Telnet, or HTTP for Web based management.
- **Local Port.** Network managers connect to the network device via a local port, i.e., RS-232 port, on the device using a laptop or similar computer. This method usually requires the network manager to be in close proximity to the network device. The protocol used for this may be Telnet, or HTTP for Web-based management.
- **Modem Port.** Network managers connect to the network device remotely using a modem interface on the device. Communications are usually over the Public Switched Telephone Network (PSTN) and operators may dial in from remote locations. The protocol used for this may be Telnet, or HTTP for Web-based management.

There are several security services that apply to secure network management. The first line of defense for network management is authentication. Administrators must first authenticate themselves to the network device to prove they are who they claim to be. Closely coupled to authentication is access control. Once an administrator's identity has been proven, their privileges must be determined. There should be several administrative roles on each device, each role with its own set of privileges. This allows each administrator to perform their job duties, but does not grant global privileges to each administrator. An audit log that links administrators to events and the time those events were performed is important. Such an audit log provides a mechanism for determining if a security violation has occurred, who is responsible, and suggests precautions for preventing similar events in the future. Finally integrity is important to ensure that communications between network managers and network devices are not altered while traversing the network. It is critical that configuration files on the devices are not modified by unauthorized personnel.

Traffic flow security for network management traffic may be of concern to some organizations. Network management traffic contains addresses of network components, or other information that may be sensitive. Providing confidentiality for network management traffic will provide protection for information while in transit through the network.

## 5.1.5 Framework Guidance

Our analysis of BN availability has resulted in some general guidance. This guidance is applicable to all of the network technologies that should be implemented to protect the availability of these networks:

- **Protection of Network Management Communications.** While the content of network management traffic is not considered critical, the integrity and authenticity is critical. Digital signatures or some form of secure hashes should be incorporated into all critical network management traffic. These communications also include the vendor-supplied software used to manage the network assets. If traffic flow security or disclosure of information within the network management traffic is a concern, confidentiality should be provided.
- **Separation of Network Management Data.** Backbone availability is not dependent on the protection of user data, but it is dependent on the protection of network management traffic. Countermeasures should be employed to isolate network management traffic from user data. One mechanism is to use an out-of band or dedicated communication channel, such as SS7. The value of separating management traffic from user traffic is to allow the infrastructure to provide the appropriate protection to the user data while impacting network performance only minimally. Network management data should be separated from the user data, and should be protected cryptographically. There are several means available for providing this protection, including encryption, digital signing, and cryptographic checksums.
- **Protection of the NMC.** The NMC is the critical element for maintaining control of the network. As long as the NMC can access the network, the network managers can respond to attacks. The NMC should be protected using the appropriate procedural and physical controls, and network security devices. A security device commonly employed today is a firewall. The NMC should consider constraining its operations to the management of the network. Permitting duties or capabilities beyond that which is necessary to manage the network provides a potential point of attack against the NMC.
- **Configuration Management.** System owners and operators should adopt formal configuration management practices. Strong configuration management allows network managers to restore network operations quickly and effectively after an attack. Configuration management supports the proper implementation of new releases of network software and the implementation of security upgrades. Strong configuration management also protects new releases of network software as the vendors develop them. Finally, it supports rigorous security design and analysis of the system.

The following section provides guidance for the protection of IP data networks. As technology assessments are completed for the other data networks, matching guidance will be incorporated into the framework.

## **5.1.5.1 IP Data Network Guidance**

### **Routing Security**

There are commercial implementations of cryptographic checksums applied across routing update messages.

### **Address Space**

Some government sponsored WANs may have the requirement to protect the addresses of the network elements. To accomplish this static routes must be configured between the WAN and each adjoining network. Network Address Translation (NAT) must be configured at the wide area border node to hide the addressing scheme of the WAN. Conversely, the local network may have the requirement to hide their address from the WAN. In this case NAT must also be configured at the local border node.

In the case of a public carrier network as the WAN, the addressing scheme may not be able to be protected.

### **Filtering**

Filtering, as it is traditionally thought of, is generally not applicable to WANs. Services cannot be filtered because it is likely that every service will be required by at least one user network. However, filtering is applicable to the area of network management. Each network device should contain a list of identifiers that describe the administrators with configuration/viewing privileges on that device. This has historically been done on IP address. IP addresses are easily spoofable. Another mechanism in addition to IP addresses is required to determine which administrators are capable of modifying/configuring each device.

### **IP Security**

IP Security (IPSec), as defined in RFC 1825, is a set of protocols supporting the secure exchange of packets at the IP layer. To achieve this, IPSEC employs two cryptographic security mechanisms: the Authentication Header (AH) and the Encapsulating Security Payload (ESP). These IP-layer security mechanisms may be used together or separately. IPSec is currently being incorporated into vendor products. IPSec functionality should be available in commercial IP network elements.

While IPSec is a suitable set of protocols for providing confidentiality for user traffic, it was not designed to provide security for intra-network communications. IPSec may be used to

implement some VPN scenarios required for segregation of user traffic over the WAN. IPSec is not viewed as being able to provide security to achieve WAN availability.

## Network Management

**Inband.** Inband network management is performed using SNMPv1. There are no security features inherent to SNMPv1. All Management Information Base (MIB) information must be considered accessible to an SNMP agent. Devices typically employ IP address filtering to limit the management stations that may configure/manage the devices. While it is recommended that this feature be used in WANs, it is not sufficient to prevent unauthorized access to network resources. IP address spoofing is common and easily implementable. The recommended approach to inband network management is SNMPv3. SNMPv3 provides confidentiality, integrity, and authentication, and timeliness functionality to inband management.

**Ethernet Port.** Constructing a separate Ethernet network to provide network management is a secure method of network management. It is a physically separate network, which provides a larger degree of control of the network management network. However, for WANs, this approach is not practical. The network elements are geographically disperse and it not feasible to construct another WAN for management. If Ethernet port management is not being used, it is recommended that the network device be configured to disallow network management connections through the Ethernet port.

**Local Port.** It is critical that IP network elements can be securely accessed through a local port. This is often the network's configuration method if the BN element cannot be reached through the network. Physical security of the devices is important to protect the local port. If an attacker does not have physical access to the device they cannot be successful. Authentication and access controls are also critical. There should be several different administrative roles on the network elements. When administrators authenticate themselves to a device, they must assume a role with well-defined privileges.



## UNCLASSIFIED

Availability of Backbone Networks  
IATF Release 3.1—September 2002

### References

1. “The President’s Commission on Critical Infrastructure Protection - Report Summary”,  
[http://www.info-sec.com/pccip/pccip2/report\\_index.html](http://www.info-sec.com/pccip/pccip2/report_index.html)

## 5.2 Wireless Networks Security Framework

The Wireless Networks Security Framework section has been added as an element of the Information Assurance Technical Framework (IATF) to discuss the security of new wireless communications technologies. This section is incorporated because the IATF addresses many security concerns and secure infrastructure elements that also affect wireless communications. Exposure of wireless communications in the radio frequency (RF) transmission environment, and the portability of computer processing and storage that wireless connectivity provides, add another set of vulnerabilities to the vulnerabilities of wired network systems. This section will present the areas of security where wireless communication presents additional vulnerabilities, different customer requirements, and different, although related, security concerns.

Wireless network protection addresses the need to ensure security of user communications where one or more links in the communications channel traverse a wireless link. “Wireless” is defined as the set of services and technologies that does not include more traditional legacy radio communications such as land mobile radio (LMR) and military point-to-point and netted military satellite communications (MILSATCOM). RF systems are addressed separately because the government legacy systems were typically designed for specific applications and included required security mechanisms. The new wireless technologies are commercially based and are not built to specifications for government applications, although the number of government applications for such systems is increasing rapidly. Security measures for new wireless systems must be developed in conjunction with the equipment manufacturers and service providers involved in the wireless industry.

“Wireless,” in this context, defines a set of commercially developed systems and products, and a system infrastructure, that transfers personal communications from wired to RF transmission environments. Wireless communications often are provided as a service to the user where the user does not own the communication infrastructure. These systems often do not require user licensing or user spectrum management (at least in the United States). Typically, wireless systems use low-power transmission and/or spectrum-spreading techniques in short-range communications environments. The characteristics used herein to define wireless are—

- RF communications in commercial and unlicensed frequency bands
- Low-power, short-range communications systems using enhanced processing and multiple transmitters to achieve range when required
- Commercially owned and operated communications infrastructure (there are exceptions)
- Commercial standards
- Vendor proprietary protocols
- Mobility of users and communications.

## UNCLASSIFIED

Wireless Networks Security Framework  
IATF Release 3.1—September 2002

As we describe the technologies and applications involved in wireless systems, the reader will note that there are exceptions to each of these characteristics. Wireless communications, rather than being a set of discrete technologies, applications, and implementations, actually form a continuum of capabilities that connect across the boundaries of the system definitions we provide. Wireless technologies also, in most cases, rely heavily on the wired network and telecommunications infrastructures for their interfaces and proper function. These interconnections are significant in discussion of security.

Wireless equipment may be used by travelers or telecommuters to remotely access their local area networks (LAN), enclaves, or enterprise computing environments. However, most remote access situations involve connecting through wired telephone or commercial data networks. Discussion in this section of the framework focuses on wireless communication networks in general, regardless of the systems being accessed through the network. As digital wireless telephony, two-way paging, wireless LANs (WLAN), and other wireless technologies gain strength in the marketplace, both government and industry users are becoming increasingly reliant on wireless communications for their daily activities. With this in mind, these devices must operate in untrusted, highly mobile, and potentially hostile environments.

There will be some overlap between the options presented here and those presented in other portions of the IATF because the majority of wireless communications networks in use today tie into a larger, wired network with additional security concerns. Previous sections of the IATF have addressed the data network portion of these wired concerns in great detail, and references are made throughout this chapter to those IATF sections, as applicable. Securing wireless communications across network segments implies a unique set of challenges that must be addressed within this framework document in order to provide layered security services, as outlined in the defense-in-depth strategy.

In today's marketplace, the consumer has access to a wide variety of wireless devices, including digital wireless phones, mobile satellite circuit-switched and packet services, WLANs, pagers, and wireless private branch exchange (PBX)/local loop devices. Each device interacts differently with existing wired networks, often through a private gateway or a service provider's network equipment. Additionally, different users have different connectivity and communications security needs. Information protection mechanisms can provide authentication and confidentiality but definitely add to the cost of the equipment. Therefore, before purchasing any wireless communications equipment, users should make a decision regarding connectivity needs and the sensitivity of the information that will traverse their wireless network. Based on these decisions, appropriate protection mechanisms can be selected to meet user needs.

This section examines several categories of wireless technology, addressing the functional requirements, security requirements, and mechanisms involved at each point in the communications and processing links. Security requirements will focus primarily on the following areas: identification and authentication (I&A), access control, data confidentiality, data integrity, and availability. These requirements for wireless systems do not replace those discussed in earlier sections. Instead, they are the same as the security requirements presented for wired networks but may have differing emphasis due to RF exposure, and differing implementation requirements. For example, if a (Unclassified but Controlled) WLAN is

connected to a public network such as the Internet, the requirements discussed in Sections 5.3, 6.1, 6.2, and 6.3 are fully valid. RF transmission of sensitive or classified data adds other variables to the equation in terms of ensuring that the message is received by only the intended recipient, detecting location of users, and combating denial of service—caused by techniques such as jamming. In such situations, a wireless network connection will often expand virtual private networks (VPN), protection of network access (PNA), remote access, and even multilevel security (MLS). Typically, wireless systems connect to their wired counterparts at the same security level as the wired system, although the use of end-to-end confidentiality can permit users to “tunnel” through the wired system at any level of classification without mixing different classification levels. The provision of security mechanisms for High-to-Low, Low-to-High, and need-to-know is entrusted to processors within the system just as it is with wired components.

In developing the security solutions framework for wireless communications, we have subdivided commercial wireless communications into topical areas based on differences in application and implementation technology. Admittedly, there is overlap as providers merge applications to provide new services and maximize customer base (e.g., paging over cellular phones in Personal Communications System [PCS] networks). The wireless topics covered here are divided into the following areas:

- Cellular telephone
- Low Earth orbit (LEO)/medium Earth orbit (MEO) satellite telephone networks
- WLAN
- Paging (one-way and two-way)
- Wireless telephone (wireless PBX, wireless local loop [WLL], and cordless telephone).

Figure 5.2-1 shows a combination of the wireless services attached to a set of wired infrastructures. It depicts a boundary around the various wired information transfer services that includes both data network systems and circuit-switched systems, which typically provide voice communications. Each type of wireless implementation effectively creates a hole in the wired infrastructure boundary because it exposes information in the system to the RF medium where signals can be much more readily detected and intercepted than in wired communications systems.

Figure 5.2-1 demonstrates that security measures implemented in the wired infrastructure can be negated by wireless connections. For example, a user community might have a wired VPN that is secured using a combination of encryption, access controls, and firewalls to create a security boundary, shown as the oval in the figure. The connection of wireless components to the VPN (e.g., wireless LAN, cell phones) can expose the VPN users and their data to over-the-air signal intercept. Such interception is readily accomplished. The wireless assets, if not properly implemented, thus punch holes in the security boundary. These holes are depicted as the breaks in the oval in the figure.

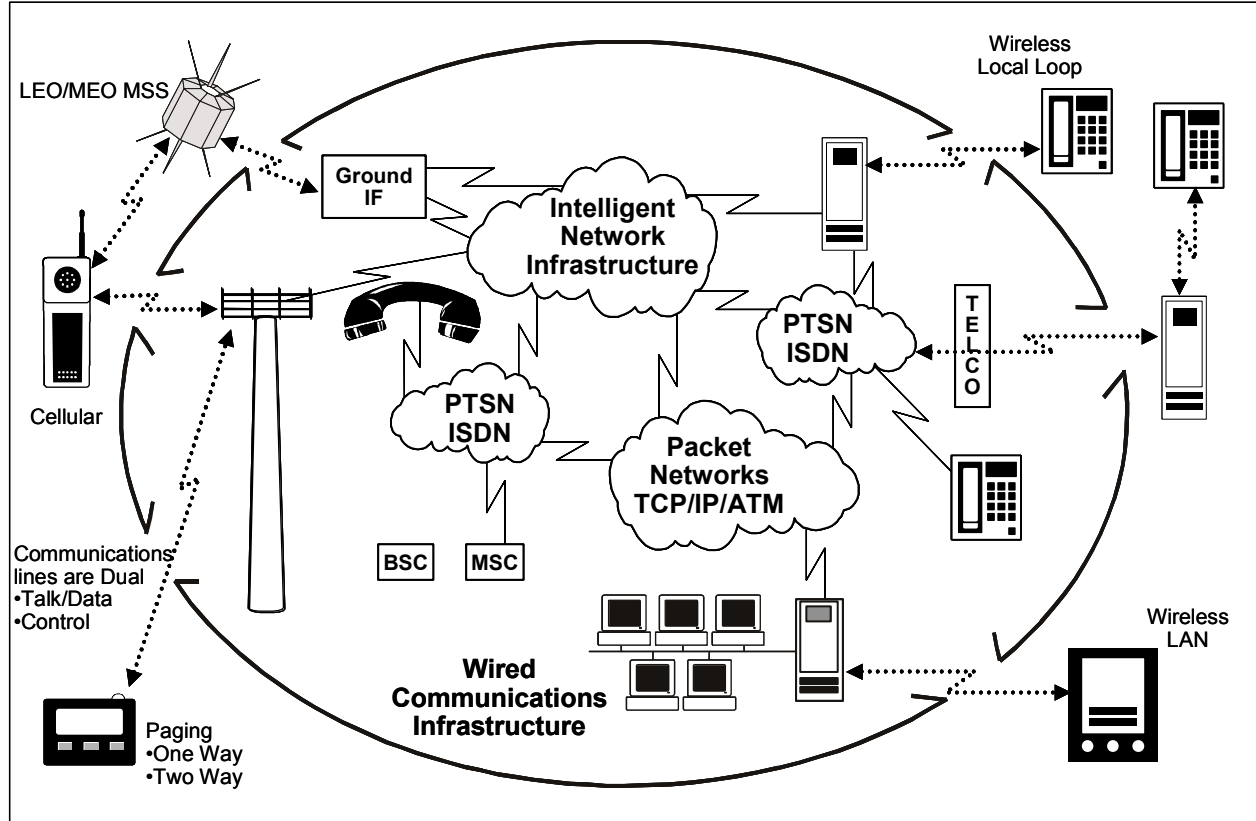

iatf\_5\_2\_1\_0005

**Figure 5.2-1. Wireless Extension of the Wired Infrastructure**

Wireless technology and capabilities are moving so rapidly that continuous updates to this document will be required to attempt to stay abreast of increased bandwidths, new modes of wireless operations, new product and service offerings, and the aggregation of services. As wireless technology services are enhanced, new vulnerabilities and user risks will be introduced.

Throughout this section, comparisons are made between several different types of wireless networks and their wired counterparts. New threats and new vulnerabilities in the wireless arena add a different dimension in security requirements and considerations for designers and consumers. Some of the vulnerabilities and risks described in this section of the IATF are common to both wired and wireless networks and communications media. This section will emphasize areas of risk that are increased by the use of wireless communications media. The framework will highlight critical gaps in current government and commercial security technologies.

## 5.2.1 Cellular Telephone

As technologies have advanced, cellular applications and terminology have become confused. Originally, “cellular” referred to a dialed analog voice telephone call technology that made use of distributed transceivers in line-of-sight communications with connections to the circuit-

switched wired infrastructure. The term “cellular” no longer means the same thing for everybody because it is evolving into a digital pipeline that can be used for virtually any voice- or data-based service (bandwidth limitations notwithstanding). Cellular systems operate primarily in the 800–900 MHz range and the 1.8–1.9 GHz range using either Time Division Multiple Access (TDMA) narrowband or Code Division Multiple Access (CDMA) wideband RF modulation. These distinctions of frequency and modulation do not substantially modify the services offered by cellular providers but are in some cases germane to the security of the systems. All cellular systems provide an over-the-air control channel from the cellular base station in addition to multiple user “talk” channels. This arrangement means that the bulk of the system control is out of band with reference to user channels.

In recent years, the cellular telephone market has seen tremendous growth around the world. With the transition to digital cellular telephony and the advent of the new PCS, the wireless telephone system has become a major part of both the Defense Information Infrastructure (DII) and the National Information Infrastructure (NII) for mobile users. Moreover, users desire similar functionality with wireless telephones to the functionality they have become accustomed to with standard wired telephones, including call forwarding, conference calling, and secure calling. Specialized militarized systems have been developed where vehicle transportable cell base stations are used as cellular telephone communications hubs. The user instruments that support cellular communications have grown increasingly capable in mobility, processing, storage, and communications capability. This aggregation of capabilities provides enhanced user functions, but also increases the risk of loss of sensitive information, denial of service, and spoofing of user messages and identities.

### **5.2.1.1 Target Environment**

This framework examines the standard wireless telephone environment, described as an end user with a hand-held telephone, roaming throughout a cell-based infrastructure owned or at least controlled by a cellular service provider. As shown in Figure 5.2-2, the cell towers connect through a base station to their mobile telephone switching center (MTSC), which provides connection to the public switched telephone network (PSTN) or if service is procured, to the Defense Switched Network (DSN).

Figure 5.2-2 can be broken into three major sections: the user environment, the service provider network, and the public network. The user environment consists of the hand-held phone and associated user, and the traffic and control channels. The service provider network infrastructure includes all equipment and connections from the cellular transmitter through the base station and on to the MTSC. The MTSC is the gateway to the PSTN or DSN for wired routing of calls. The PSTN includes connections to wired users, the Internet, and other mobile network providers. Each segment varies in the levels of privacy and availability provided to the user.

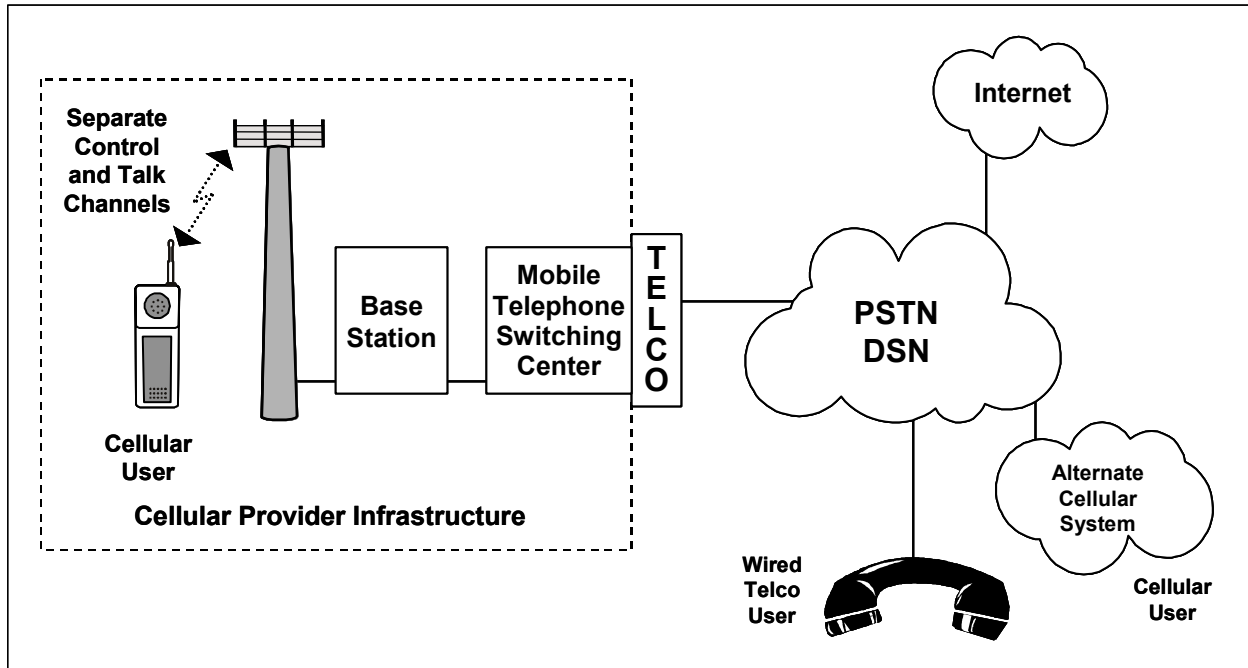

Figure 5.2-2. Cellular Telephone Environment

## 5.2.1.2 Consolidated Requirements

Users of wireless networks require functionality from their wireless equipment similar to what they get from their wired counterparts. Wireless telephony is certainly no exception. In discussing the following capabilities and postulated functional requirements, particular attention is paid to functions associated with connecting a wireless user to an existing wired network.

### 5.2.1.2.1 Functional Requirements

- Users/User Equipment
  - Should provide maximum portability and mobility for the user.
  - Must have individual identification (ID), e.g., unique phone number.
  - Must provide unique ID of user instrument.
  - Must be able to provide location to the service provider system, e.g., Emergency 911 (E911).
  - Must have service availability within full assigned area of provider network.
  - Must ensure confidentiality of control channel and voice/data channel information.
  - Must provide protection for information stored and processed in user equipment.
  - Must provide user with maximum allowable access to needed information and services.
  - Must be compatible with different signaling protocols for operation in different locations when outside home network.

- Must interface with wired and wireless user communities.
- Should provide certificate and key management and distribution interfaces for authentication of users.
- Should maximize user instrument operating time (battery life).
- Geolocation is both a benefit provided by cellular systems (under certain circumstances) and a risk for cellular users when the function is not desired. Federal law for E911 service requires geolocation of users for emergency situations. At the same time, the greater precision of the geolocation and the availability of that information in the cellular system put other users at risk during clandestine operations.
- Service Provider
  - Provide high grade of system availability for users.
  - Provide high-quality voice and error-free data services for users.
  - Protect user information (e.g., ID and location) within the cellular infrastructure.
  - Provide priority service for critical users.
  - Provide capability for user communities to manage allocation of user services.
  - Manage security of user provisioning and location information.
  - Protect against the full range of network attacks (e.g., cloning, eavesdropping, impersonation).
  - Provide signaling technologies that are compatible with multiple user instruments.
  - Provide protection against jamming and other denial-of-service attacks.
- Interface to Public Network
  - Provide minimal operational impact on user and phone performance.
  - Provide accurate billing method.
  - Provide dedicated connections from mobile telephone switch to telco.
  - Provide wired telco services (e.g., caller ID).
  - Provide standard interface with telco systems.

### 5.2.1.2.2 Networking Environments

- The networking environment in a wireless telephone network is not as clearly defined as it is in a computer network. One of the significant differences between a cellular network and a computer network is the level of access provided to a user. Local access to a computer network can provide universal access to all systems connected to that network. Access on a cellular network is much more limited for the end user, that is, access to a selected called party. However, with the increased use of the data capabilities of digital wireless telephony, a cellular network may begin to resemble the more familiar computer network. Wireless telephones should offer conference calling, as well as the ability to broadcast data to one or many recipients simultaneously.
- The networking environment should maximize the user's ability to use the service within the full boundaries of the service area. Fading and interference characteristics vary depending on site structures and modulation techniques. Users should investigate these



characteristics for different providers in areas of critical operations for service continuity before selecting a provider.

### 5.2.1.2.3 Interoperability Requirements

- Service providers and associated handsets should not force users to use any nonstandard protocols, modes of operation, or procedures that would prohibit interoperability with external users or systems with which users desire to communicate.
- Different cellular infrastructures currently make certain handsets inoperable in many areas around the world. In addition to the varying protocols, frequency allocations differ globally. While equipment is being manufactured to operate in different frequency bands, switching between protocols like TDMA and CDMA is more challenging. From a network security standpoint, users must carefully consider how transmitted signals affect detectability, availability, power control, jamming, and interception. Based on these considerations, the proper technology should be available to meet the user's needs. Regardless of the primary digital multiple access technique used, cellular handsets that can revert to a more universal system like Advanced Mobile Phone Service (AMPS) are extremely useful when the mobile user is outside of his or her normal area. However, AMPS is gradually being replaced and will not be widely available in the future. Future cell phones will be equipped to handle multiple types of more modern protocols.

### 5.2.1.2.4 Anticipated Future Requirements

- Convergence of technologies is demanding access to Internet services from the wireless telephone. Manufacturers have begun providing this service with a combination of wireless telephone and personal digital assistants (PDA). Increases in channel bandwidth to (in excess of) 100 Kbps have made Internet connection a viable reality.
- Wireless phones will require operation with a smart card or a Subscriber Identity Module (SIM) card for such future technologies as electronic commerce. These cards are also referred to as tokens. A token can be implemented in hardware or software, depending on the required assurance level for the transmitted information.
- Tokens will help cellular phones provide digital signatures, as well as end-to-end confidentiality of information. The security features required for electronic commerce can also be used to implement security features for sensitive and classified traffic.
- The ability to use a single-user instrument for different types of cellular protocols (and other wireless capabilities such as mobile satellite service [MSS], paging, WLAN, cordless phone services, and wireless computer synchronization) is now coming on line. Universal handsets will be available in the near future. This will reduce the cost of confidentiality and other security mechanisms because the security will not need to be implemented for multiple protocols, but could rather become a user application that is independent of the network for end-to-end security requirements.

- The number of communications modes and interfaces described in the previous paragraph will require some common form of authentication and other common security solutions.
- Increased information transmission over the user and control channels will require enhanced security for those connections. For example, caller ID is now becoming available, and E911 will carry very specific geolocation information over the RF path.

### 5.2.1.3 Potential Attacks

The primary concerns of the cellular service provider are theft of service and denial of service. While different types of users may or may not be concerned about the confidentiality of the information transmitted and received by their wireless phone, commercial service providers definitely want to ensure that the cellular system prevents unauthorized use of their service by a nonpaying customer and that the cellular service is functional for paying customers. Confidentiality of the information is typically a secondary objective for the service provider, but a primary concern for business and government users.

#### 5.2.1.3.1 Passive

- Eavesdropping operations were relatively simple with analog AMPS handsets. The change to digital technologies has increased the difficulty of passive eavesdropping, but devices can be readily modified to provide channel scanning and intercept capabilities. Without a true encryption scheme, passive means can result in a major attack.
- Geolocation by an adversary via direction finding, cell location, or E911 requirements.
- Traffic analysis via dialed phone numbers and caller ID.
- Spoofing. Attacker intercepts data, splices in information, and retransmits the message as if originator of the message.

#### 5.2.1.3.2 Active

- As shown in Figure 5.2-2, a distinction must be made between the voice/information channel and the control channel. Interception of control channel information is a bigger threat to service providers, while users are typically more concerned with the confidentiality of the “talk” channel.
- Denial of service by jamming or altering control channel data can be a threat to users and service providers in cellular networks because of the vulnerability of control channel information when it is transmitted over the air. Such attacks typically require physical access to a provider’s network equipment, although outsider spoofing can modify the control channel.

- Outsider control of the transmit power of the user hand-held device allows an attacker to conduct locating and tracking operations against a target. Also, an attacker could cause denial of service by limiting the output power of a user's handset below what is required to maintain a connection.

### 5.2.1.3.3 Insider

- Duplicate smart cards or SIM cards (copy user token).
- Steal information on user identification and user traffic via control channel intercept.
- Modify control parameters of the system infrastructure.
- Modify user's phone.

### 5.2.1.3.4 Distribution

- Hardware or software modification in transit could be used as a first step in a complete attack by which an adversary eventually could cause the system to send data or allow access by way of electronic connections to information for which he or she is not authorized. These attacks, however, are not the emphasis within this section.
- The distribution attack is enhanced by the fact that user instruments are becoming increasingly modular. Thus, a user capability is assembled from parts that were distributed separately. Such components include storage devices (disks, flash prom) and communications devices (e.g., PC card modems, wireless modems, and WLAN cards) that could spread viruses and open undesirable communications channels.

### 5.2.1.3.5 Other

- Theft of portable user devices containing sensitive information and user programs is also a risk. The increasing integration of processing and communications elements in mobile systems can make the theft of user equipment very destructive because of the storage volume and aggregation of information on that equipment.

## 5.2.1.4 Potential Countermeasures

Sufficient countermeasures must be implemented to provide privacy, authentication, and message integrity in accordance with the level of information being transmitted. Type 1 security, primarily for the DII community, requires countermeasures that provide the maximum possible security for message traffic. Sensitive information requiring Type 2/3 security requires less stringent countermeasures. In order to maintain a secure infrastructure, the Government must overlay a supporting system infrastructure to incorporate authentication and key management and other countermeasures for each level of information as appropriate. Chapter 8, Supporting Infrastructure, is dedicated entirely to discussion of supporting secure infrastructure, and Section 8.1.5.14, Attacks and Countermeasures, covers attacks and countermeasures in more detail.

### **5.2.1.4.1 Encryption**

The primary security requirement for cellular phones, as with any RF transmission system, is protection of user information over the air. There are two primary modes for protection. The first is encryption to secure the information and transmission security (e.g., signal spreading or hopping) to protect the channel and possibly to provide protection against signal detection. Information on the control channel is also user related at times in that it provides information on location, privileges, called party, and calling party. Such information is very valuable for traffic analysis. A second important requirement for users is I&A of the parties in a communications session.

The Federal Bureau of Investigation is presently promoting a law that will prohibit sale of encryption devices for use within the United States that do not provide key recovery services to support Communications Assistance to Law Enforcement Act access. Although the law has not been implemented, it appears that cellular service providers are slow to implement encryption services until the implications of a key recovery law are known. However, the techniques and standards for certificate and key management and encryption exist within the data network world to permit firmware or software encryption to be implemented for sensitive communications. Encryption algorithms can be embedded or implemented on the same tokens that provide user identification and privileges.

Inband signaling is also a target for encryption to prevent traffic analysis. For instance, encryption of dialing and data digit signals sent over the RF network must be considered, as well as caller ID information that precedes a received communication. This will help secure credit card transactions, personal identification numbers (PIN), other account numbers that are entered to access commercial dial-up services, and the identities of calling and called parties.

### **5.2.1.4.2 I&A**

SIM cards and other small token form factors may provide the best countermeasure to enable user and user terminal authentication (and security management). If a phone is stolen, for example, the user can notify the service provider, who then deactivates the SIM card in the stolen phone. The phone can even be programmed to flash “Stolen Handset” to notify the thief that the handset is useless. The same measures that providers use to prevent theft of service from the provider can be adapted to provide I&A security services. For increased security, service providers can permit user groups to control access of their own individual members using software tools that the service providers use to provision systems. The same provisioning capabilities can be expanded to include information such as security clearances, access to keying and other security management infrastructure (SMI) services, and restriction of services within the limits of the overall provisioned (and paid for) service.

### **5.2.1.4.3 Availability and Integrity**

The availability and integrity of communications are largely a function of the protocols used by the service provider to connect calls, to provide reliable communications channels, and to service

an optimal number of customers. As with any telephone system, busy channels are possible, although a busy system (rather than called party busy) is much more likely in cellular systems depending on the number of subscribers within a given cell or coverage area. To maximize the number of users in a given area, the RF power output is often controlled for provider and/or user equipment on a dynamic basis to within a tolerable channel error rate for digital voice communications. Error correction codes are then used to correct the errors that would not be tolerable for data communications. To enhance both availability and integrity, a caller priority technique could be implemented to eliminate busy connections for critical calls and to reduce the number of concurrent general user calls processed within a given cell area in support of emergency operations.

### 5.2.1.5 Technology Assessment

Within the wireless telephone market, current technology is more than adequate to permit insertion of required security into most applications, but few security measures have been implemented. As discussed earlier, the best available security technologies use some sort of token (physical component or inserted code) to provide authentication, access control, and data confidentiality. Lessons can be learned from the use of SIM cards with Global System for Mobile Communications (GSM) phones in the European market, where a user must have both a SIM card and a password (passwords are optional) in order to operate the telephone. Hardware or software tokens can be issued to every individual requiring sensitive communications who will use a wireless telephone in the future. Regardless of which protocol is used in a mobile telephone, the technology is available to ensure that these tokens provide continued high performance and ease of use for the mobile user, as well as providing a mechanism for implementing the required security. For U.S. government applications, cellular end-to-end secure handsets are under development to satisfy Department of Defense (DoD) and other government high-security requirements. Currently, the DoD is fielding Type 1 secure CDMA and GSM phones.

To manage the approval and provision of tokens and security privileges, an SMI infrastructure is required. Presently, the software cryptography implemented in some systems provides protection only for the lowest levels of assurance.

Communications bandwidths (typically less than 20 Kbps) are not yet sufficient to support efficient public key distribution capabilities over the cellular communications channels, but the picture is changing in two ways. High bandwidth cellular services (over 100 Kbps) will be coming on line within the next several years, and new techniques for key and certificate distribution based on elliptic curve cryptography will provide more efficient transfer mechanisms. In combination, these capabilities will minimize call setup times and reduce the airtime cost of security to the point where a more widespread user base will consider the use of public key capabilities.

## 5.2.1.6 Usage Cases

Other sections of this framework have addressed several cases involving connecting equipment at one classification level to equipment at the same or a different classification level across both trusted and untrusted networks. These cases are clearly an IATF issue but also apply in the wireless domain. However, use of wireless equipment interfacing with a wired network does not significantly change the cases that were previously discussed. In general, some level of communications security is recommended for any equipment where there is a connection to a potentially hostile or unknown environment. In the case of cellular communications, all transmissions can be thought of as connecting to an unknown environment because of the nature of RF transmissions and the ease of signal intercept. Thus, the descriptions of each of the specific cases addressed in this framework remain unchanged for the wireless environment. Cellular calls are treated herein as having the same levels of classification as the wired systems to which they are connected. An exception involves the use of high-grade end-to-end confidentiality of the wireless service so that the user is independent of the classification level of the wireless or wired networks to which he or she is connected.

The cellular user scenario to be discussed is the voice phone call from/to a cellular portable phone system. Although the scenario appears to be quite simple, the actions required for the establishment and conduct of the call are quite complex. This “simple” example involves only a voice phone call; that is, it involves no data, pager, or other service that might be available under services such as PCS.

Three types of connections are addressed in this scenario:

- The cellular user calls a plain old telephone service (POTS) user.
- The cellular user calls another cellular user (same or different provider).
- The cellular user calls a satellite telephone user (e.g., Iridium phone).

The risks to users under the three scenarios are similar in terms of over-the-air exposure, but there are differences in denial of service and quality of service that must be considered. The risks presented below will call out the specific situation under which a certain risk or degradation in service occurs.

It is important to note that any communication over commercial facilities opens up a large number of paths for the call control and user voice information to follow. The user has little to say about what path his or her information will take or where important information related to the user will reside. As shown in Figure 5.2-2, for cellular voice calls the paths that can be taken by a call are varied.

Before the user ever gets to the point of making a telephone call, the user has to establish service with a cellular provider. When the service is established, the parameters are set for local service areas and roaming areas, as well as for billing-related items (e.g., free call minutes). All of these parameters are checked before calls can be completed. The user privileges can be checked rapidly by the provider through the use of the wireless intelligent network (WIN) that provides a

## UNCLASSIFIED

separate control system for the networks (separate from the cellular user channels themselves). User-related information is readily available within the cellular control infrastructure.

There are several important security-related elements to consider in making cellular phone calls:

- **Service Is Not Assured.** In an emergency and during peak usage periods, call overload can lead to denial of service for individual phone calls. Spurious or intentional signals sent by third parties can cause calls to hang up. A moving user can experience dead spots within the service area. In certain locations, such as urban areas, call coverage can be very spotty due to electronic and physical interference. Transition of calls between cells is not assured. Since cellular systems are implemented based on user population, many areas with low population density may not have cellular service at all.
- **User Is Identified.** As soon as a cellular phone is turned on within a service area (a call need not be made), the user is identified to the entire system. The user ID is broadcast within the cell in response to interrogation from the cellular system over-the-air signaling channel.
- **User Location Becomes Known.** As soon as a cellular phone is turned on within a service area (a call need not be made), the location of the user is identified to the entire system. The user is located to within a fraction of the cell area (typically several square miles).
- **User's Information Is Exposed Over the Air.** Both the signals transmitted from the user and the signals from the other party to the call are available over the air within the cell site. The equipment required for third parties to intercept calls is inexpensive. Nothing more than a standard cell phone is required to accomplish the interception. There are multiple hacker Web sites that provide information on how to convert a cell phone into an interception-scanning device. The use of high-gain antennas (also cheap and readily available) can extend the interception capability well beyond the cell site itself.
- **An Adversary Can Readily Deny Service.** Cellular signals can be readily jammed and are subject to interference also. Several vendors make intentional jammers to prevent cell phone operation on a given premises.
- **CDMA Technology Provides Lower Signal Exposure.** CDMA transmissions are less readily intercepted than TDMA transmissions, but CDMA transmissions are not, by any means, invulnerable.
- **Intelligibility of Calls May Be Poor.** Basic cell phones that use analog user channels can suffer from noise. Digital channels use low data rate voice encoding that can suffer quality loss through conversions from digital to analog and back in the telephone and cellular networks.
- **Users Can Be Spoofed.** Through theft of equipment or reprogramming of IDs, third parties can adopt the identity of a user and make misrepresented calls.

- **User Cellular Telephone Instruments Are Vulnerable.** As equipment becomes more sophisticated, more information is stored within the cell phones themselves. Several cellular phone models include a palmtop computer as part of the instrument. A stolen cellular instrument may contain much more sensitive information than the user's ID.

## 5.2.1.7 Framework Guidance

### User Advisory

- Cellular phones are adequate for general-purpose traffic but are typically unsuited for high reliability requirements. Numerous government organizations and law enforcement agencies use cellular telephones for general-purpose traffic but use specialized security devices and private networks (e.g., LMR) for critical communications.
- Several cellular providers offer over-the-air encryption of user information, but the security is applied only for the air link, not through the telephone network. In all cases, except the use of National Security Agency (NSA)-endorsed Type 1 instruments, commercial cellular encryption is not suited for classified information exchange. Discretion in sensitivity of information transmitted is necessary.
- Digital telephone services are somewhat more private than analog systems. Requirements for interception of analog conversations are trivial, whereas a small degree of sophistication must be applied to intercept digital connections. Also, digital connections are more readily secured through encryption, should the option be available. Use of digital cellular phones is recommended.
- Use of CDMA technology is preferable to use of TDMA from a signal interception viewpoint.
- Users must protect their cellular phone instruments from theft or loss. The cost of the instrument may be trivial compared to the value of information contained on the instrument.

### Desired Security Solution

- Users within the NII and the DII require reliable service with assurance of data integrity and confidentiality, as well as protection from handset cloning and misidentification.
- Any cellular/PCS network should provide over-the-air security (at a minimum) for both voice and control channel information.
- End-to-end security for user conversations and data transfers is required for U.S. Government sensitive and classified operations.
- Users should be protected from RF attacks and traffic flow analysis attacks.



- Systems should provide capabilities for users to be restricted to absolute need in the use of options available within the systems (e.g., caller ID), thus minimizing the amount of traffic-related information sent over the air.

## **Best Commercially Available Solution**

- The best current solutions involve using a PCS phone or a GSM phone with a SIM card to provide user I&A.
- Cellular providers have adopted RF signature evaluation techniques to find stolen cellular user instruments.
- Network providers currently secure billing information through the cellular and PSTN networks.
- GSM standards provide for encryption of user channels within the provider secure infrastructure (i.e., as far as the wired telco interface). This encryption is from the cellular phone to the base station only and is not sufficient to protect classified or sensitive information.

## **Technology Gaps**

- Adequate security mechanisms to implement Type 1 security for U.S. government classified operations, for example, insertable or software-based high-grade encryption.
- Protocol-sensitive encryption techniques to protect multiple data protocol types.
- SMI within the service provider network to include user security privilege establishment, maintenance, and distribution.
- User-operated control and provisioning systems to allow rapid reconfiguration of user privileges to modify services in emergency quick-response operations.
- Modified modulation techniques for spread spectrum systems (e.g., CDMA) to decrease the effect of electronic jamming and reduce the probability of detection for covert users.

## **5.2.2 Low Earth Orbiting/Medium Earth Orbiting Satellite Telephone Networks**

LEO and MEO satellite telephone networks, often referred to as MSS, are the next stage in worldwide, portable telephone connectivity. Unlike the cellular/PCS systems discussed earlier in this section, these handsets will provide telephone connectivity from anywhere in the world where the subscriber elects to pay for service. The traditional cell structure and roaming environment changes significantly with these networks because the cells are now moving and the users are remaining relatively stationary compared with the faster moving LEO satellites.

LEO satellites circle the planet many times each day at orbit altitudes of 300 to 1,000 miles. The engineering is very complex because these systems cover large areas with many small, low-powered satellites. Currently, only two satellite services are scheduled to be partially available now or in the near future: Iridium and Globalstar. In one case, there will actually be handoffs between the satellites, as shown in Figure 5.2-3. Advantages of these services will include worldwide coverage, the ability to use portable phones, and automatic searching for a terrestrial (cellular) service before switching to the satellite. Many MSS phones scheduled for commercial use operate with local digital cellular networks as well as with the satellite network. Because of the present high per-minute cost of satellite communications, the phone will/should first try to access a local cellular system when making a call. If no cellular service is available, the satellite service is used.

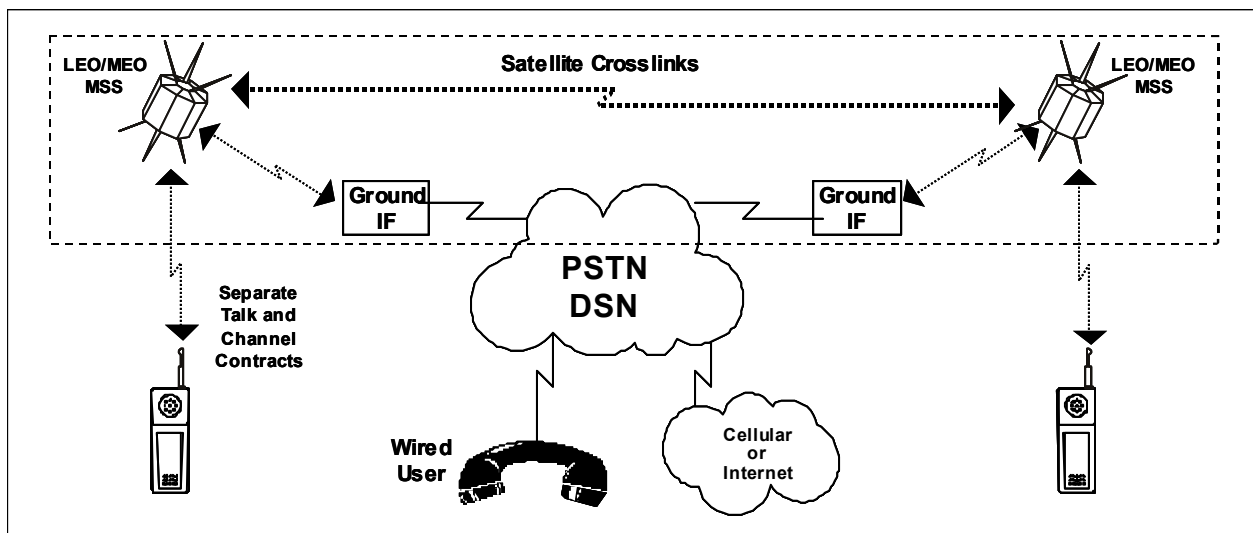

latf\_5\_2\_3\_0007

Figure 5.2-3. Mobile Satellite Subscriber Environment

### 5.2.2.1 Target Environment

The target environment is very similar to the cellular case where a user is making or receiving a phone call from a portable mobile user instrument to another portable instrument, to a wired telecommunications user, or to a cellular telephone. In this environment, the user and recipient can be anywhere in the world.

As previously presented for the cellular case, the elements of Figure 5.2-3 can be broken into three major sections: the user environment, the service provider network, and the public network. The user environment consists of the hand-held phone and associated user, as well as the talk and control channels. The service provider network infrastructure includes all equipment and connections from the satellites and earth stations, the satellite control infrastructure, and the ground entry points that interface with the PSTN. The public network includes connections to wired users, the Internet, and other mobile network providers.

## 5.2.2.2 Consolidated Requirements

The following requirements are proposed for government utilization of MSS capabilities.

### 5.2.2.2.1 Functional Requirements

- Global coverage area for call transmission and reception.
- Continuation of call connection from satellite to satellite.
- User and recipient I&A.
- Voice and data confidentiality and data integrity.
- Transmission of voice and data.
- User geolocation capability (both beneficial and a vulnerability).
- Long user instrument lifetime (battery power).
- Accurate and timely billing procedures.

### 5.2.2.2.2 Networking Environments

- Cross-connected satellite constellation for primary call handling (vendor or service provider proprietary protocols).
- Data transmission capabilities of up to 19.6 Kbps currently for e-mail and other short message services.
- Interconnection to PSTN, cellular networks, and data networks.
- Worldwide paging services also available through LEO satellite networks.

### 5.2.2.2.3 Interoperability Requirements

- User instruments that can be used with the MSS system and with cellular telephone systems.
- Interfaces with all PSTN systems worldwide.
- Sufficient digital voice quality to traverse the PSTN and be intelligible in cellular systems.

### 5.2.2.2.4 Anticipated Future Requirements

- Increased bandwidth to support data transfer.
- Increased voice quality for conferencing.
- Reduced cost of user instrument to expand availability.
- Support for SMI functions.

## 5.2.2.3 Potential Attacks

### 5.2.2.3.1 Passive

- Largely the same as for cellular RF emission vulnerabilities.
- Interception of data from the satellite downlink transmission can be accomplished from anywhere in the satellite footprint (larger space than for cellular). The only drawback for the adversary in this case is the volume of information to be processed.

### 5.2.2.3.2 Active

- Denial-of-service attacks by electronic jamming.
- Like attacks on cellular systems, network attacks through LEO/MEO satellite systems are somewhat limited in scope. An adversary cannot access the entire telephone network simply by intercepting one telephone call. In other words, local access does not allow universal system access as it would in the case of a LAN connected to the Internet.

### 5.2.2.3.3 Insider

- Modification of handsets before delivery to customer.
- Duplicate handset and user ID information can be loaded into a second phone (nonsimultaneous use).
- User location information available to service provider.

## 5.2.2.4 Potential Countermeasures

Many of the countermeasures discussed in the Cellular/PCS section also apply to satellite telephones. Theft of service will most likely be the primary goal of any hacker on the MSS telephone network. Theft of information and eavesdropping will likely be a secondary concern for providers, but will be critical to certain government users. Service providers must ensure that control channel information is secure, and procedures must be in place to provide user I&A in order to prevent theft of service. Providers must also permit the use of end-to-end confidentiality mechanisms to protect user information.

With a cellular structure, creating some type of SMI incorporating key management and other countermeasures is easier within a country. Any SMI used in the LEO network must fit into more of a global management structure. However, as costs drop and satellite telephony becomes more popular, usage by customers within both the DII and the NII will likely increase. Before these telephones become useful for customers in the DII transmitting sensitive information,

sufficient countermeasures must be implemented to provide privacy, authentication, and message integrity in accordance with the level of information being transmitted.

Use of some sort of token or smart card with the telephone handsets can also be integrated into the satellite network. As with cellular systems, SIM cards may provide the best countermeasure to enable user authentication and key management. Only authorized users will be able to access the satellite network. Also, if a phone is stolen, the user can notify the service provider, who then deactivate the SIM card in the stolen phone. The phone can even be programmed to flash “Stolen Handset” to notify the thief that the handset is useless.

### **5.2.2.5 Technology Assessment**

As of this writing, service has been initiated on both the Iridium and the Globalstar networks. Proposed technologies include dual-mode (GSM/MSS) handsets, voice and data transmission, paging, facsimile, and position location. Iridium will use a combination of Frequency Division Multiple Access (FDMA) and TDMA multiple access technologies, while Globalstar uses CDMA. Type 1 secure handset for end-to-end confidentiality in the Iridium network has been developed.

### **5.2.2.6 Usage Cases**

As stated for cellular usage cases, other sections of this framework have addressed several cases involving connecting equipment at one classification level to equipment at the same or a different classification level across both trusted and untrusted networks. These cases are clearly an IATF issue and also apply in the MSS domain. In the case of wireless communications, all transmissions can be thought of as connecting to an unknown environment because of the nature of RF transmissions and the ease of signal intercept. Thus, the descriptions of each of the specific cases addressed in this framework remain unchanged for the wireless environment.

The sample case of an MSS call can be treated in a very similar manner to that of the cellular call scenario described earlier. If we take the earlier cellular case of calls to another MSS telephone, a wireline-connected standard telephone, or a cellular telephone, the cellular vulnerabilities presented in Section 5.2.1.6, Usage Cases, exist with some modifications, as described below:

- In most cases, the MSS user must preregister with the service provider for specific roaming access areas outside of home territory.
- The extended satellite footprint makes user information more available to interception since the terrestrial range over which the RF signal is broadcast is on the order of several hundred miles.
- For at least one MSS service (i.e., Iridium), user coverage is global. In other cases (e.g., Globalstar/ICO), far north and south latitudes are not covered.
- Transmission rates are typically lower for MSS services than for cellular services. Since digital voice rates are reduced, voice quality is reduced. Connections across MSS and

cellular systems may suffer degradation in voice quality to the point where user voice recognition is not possible.

## 5.2.2.7 Framework Guidance

### User Advisory

- The risks for users in using MSS services are similar to those for cellular. The range of interception for MSS calls is increased, but the risk of geolocation is reduced. Keep messages short for both security and financial reasons.
- There is insufficient data concerning the operability of MSS systems to make definitive statements on system availability and loading. Request provider information on call completion rates.
- The development of instruments and protocols for high-grade end-to-end confidentiality has begun. If you are addressing user requirements for your organization, contact NSA for status of efforts.

### Desired Security Solution

Ideally, an MSS telecommunications network will provide confidentiality for both talk channel and control channel information. Users within the Government require reliable service with some assurance of data integrity and confidentiality, as well as protection from spoofing and misidentification (e.g., handset cloning). Integration of the smart card technology used in GSM phones with the satellite phone handsets could help provide adequate protection for users.

### Best Commercially Available Solution

Currently, the Iridium and Globalstar networks are operational with some commercial-grade encryption available over the air link. The only Type 1 solution today is the Iridium Security Module (ISM) for Iridium. The ISM provides handset-to-handset encryption and handset-to-STU/3 encryption through a red gateway. The primary security needs for satellite telephone services are end-to-end confidentiality for user information and the protection of caller and calling party identification.

### Technology Gaps

- Adequate security mechanisms to implement Type 1 or Type 2 security.
- SMI within the service provider network.
- Protection of stored information in user instruments.

- As wireless telephones increase in complexity and become more like personal computers, user handsets will require a way to provide secure data storage using SIM cards or other types of tokens.

## 5.2.3 Wireless Local Area Network

WLANs are quickly gaining popularity in multiuser environments. A WLAN can be used as a stand-alone network, or as is most often the case, it can be used to increase the range, flexibility, and user mobility of a larger network. WLANs are typically implemented with personal computer (PC) cards inserted into network processors, and can also be implemented in portable devices such as hand-held computers. A WLAN uses the same transmission (Ethernet is typical) and data protocols (e.g., Internet Protocol [IP]) as its wired equivalent but provides a lower bandwidth (e.g., 1-11 Mbps versus 10-100 Mbps for Ethernet). The typical implementation for RF communications is a collision avoidance direct-sequence spread-spectrum or frequency-hopped protocol under the Institute of Electrical and Electronics Engineers (IEEE) 802.11 standard. Members of a WLAN communicate one at a time as on an Ethernet rather than in an overlay of signals as occurs in CDMA cellular systems. Multiple WLAN nets can then be overlaid in the same location and frequency range by using different spreading or hopping sequences. WLAN members have a connection distance measured in the range of 100 to 1,000 feet, depending on the environment, e.g., office building, and open space.

WLANs have gained entrance into the marketplace primarily in the vertical markets of health-care, retail, manufacturing, warehousing, and academe. These markets have leveraged the productivity gains of using hand-held terminals and notebook computers to transmit real-time information to centralized hosts for processing. Primarily, WLANs provide an advantage when mobility, scalability, and installation speed, simplicity, and flexibility are important requirements. An interesting example of a large-scale WLAN integration is the Fox Tower building in Portland Oregon. The Fox Tower will feature connectivity to a high-speed fiber-optic network, including satellite transmission, digital phone lines, WLANs, video, and high-speed digital subscriber line access, to every tenant on every floor, regardless of each tenant's current technology capacity. This is an example of the architecture providing information technology infrastructure in a flexible, scalable plan to minimize the cost of constantly upgrading the system infrastructure as tenants move or change technology.

### 5.2.3.1 Target Environment

The WLAN provides flexibility for movement of net members but requires a high degree of colocation of the wireless segments (communications range on the order of 300 feet). WLANs are often used in offices and facilities where the wiring required for a standard network has not been installed. Other applications include provision of network interconnection where the nets must be configured and torn down rapidly. A tactical military command post or forward air base is an example of the latter. The target environment, shown in Figure 5.2-4, has been drawn to represent the case where a WLAN extends an existing network through a wireless modem link.

The WLAN environment is a notable exception to the definition of “wireless” provided earlier in Section 5.2, in that, in the WLAN case, the user owns the wireless infrastructure (however small that may be). The user buys the components and does not need to rely on a service provider for WLAN operation. This fact provides flexibility in location, mobility, and applications. However, the WLAN is tied to a wired LAN environment in most cases, thus reintroducing “borrowed” infrastructure requirements.

The wired infrastructure to which the WLAN is connected can be formulated in several ways. As shown in Figure 5.2-4, the “cloud” can be the Internet or a secured environment composed of an intranet or a VPN. The security implications of connecting WLAN components to an intranet or a VPN are of particular importance. It must be noted that the range from which an observer can observe (detect or read) the signals emanating from the wireless connection is always greater than the range over which the WLAN will operate. Very simply, the use of high-gain directional antennas from a remote location provides the same receive signal strength that can be achieved by a close-in user with a standard antenna and receiver.

The key elements of the environment are the physical space where the WLAN is implemented (size and type of physical environment and its perimeter), the level of classification or sensitivity of information handled in the system, and, as mentioned in the previous paragraph, the wired interconnect mechanism. Special cases of High-to-Low classification, firewalls, and other wired LAN security elements are assumed to be handled by the wired LAN segment of the target environment.

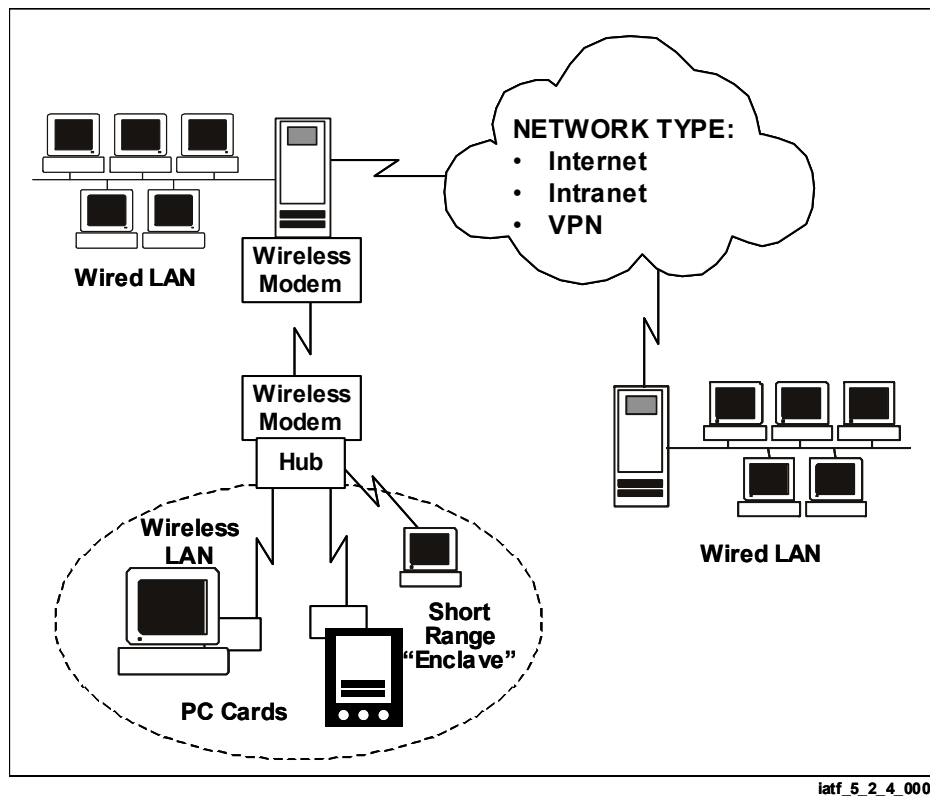

Figure 5.2-4. WLAN Environment



## 5.2.3.2 Consolidated Requirements

Users of WLANs typically connect through an access point to a larger wired network. Each access point can represent a separate user domain, or multiple access points can be assigned to the same domain to increase data throughput in high-usage areas. When connecting a WLAN to an existing network, system administrators must be careful not to weaken the existing network security of the wired LAN. The use of VPNs, as discussed in Section 5.3, System High Interconnections and Virtual Private Networks or secure wireless LAN products, will play large parts in ensuring adequate security for WLANs. Without access controls at the wireless nodes, an attacker can gain universal access to the entire network by simply penetrating a single node.

Additionally, a distinction must be made between use of a WLAN in a standard office environment and use in a highly mobile or tactical environment. An office environment will typically require a network to handle higher traffic loads and a large number of users. Tactical environments, on the other hand, will usually operate in a hostile environment. Traffic loads may vary, and networks will typically consist of fewer, more mobile users than wired cases. Requirements may differ dramatically between the two environments. The following is a list of proposed requirements.

### 5.2.3.2.1 Functional Requirements

#### User/Mobile Terminals

- Provide access control for restricted domains.
- Provide user I&A mechanism.
- Ensure VPN software compatibility to support data confidentiality.
- Support secure wireless LAN card.

#### Access Points/Network Equipment and Configuration

- Strong access control.
- Ensure network bandwidth availability. The network must be fast enough and able to handle a large number of nodes without becoming unusable.
- Ensure data integrity.
- Provide continuous authentication of all users connected to a WLAN.
- Establish secure wireless domains for each access point.

### 5.2.3.2.2 Networking Environments

- Ability to communicate with wired networks through a wireless access point within range of the LAN at data rates sufficiently high to prevent congestion.

- Ability to communicate at close range among mobile elements (ad hoc network) as in a field tactical situation.
- Provision of spreading codes that minimize interference with other wireless LANs.

### 5.2.3.2.3 Interoperability Requirements

- Networks using different modulation schemes cannot communicate directly with each other without any conversion. Both direct-sequence spread spectrum (DSSS) and frequency-hopped spread spectrum (FHSS) modulation are part of the IEEE 802.11 WLAN standard. In the standard network environment, gateways are used to translate between networks from one protocol to another.
- Collocating WLAN systems must not cause interference problems with other wireless systems in the vicinity. Spread-spectrum modulation attempts to minimize this interference. However, with the common 11-bit spreading code, WLAN systems will not attain a processing gain much higher than 10 dB (Federal Communications Commission minimum). Longer spreading codes would increase processing gain and could improve data security.
- Appropriate key management must be used to isolate/coordinate separate wireless LANs.

### 5.2.3.2.4 Anticipated Future Requirements

- Wireless networks must allow for the evolution and reconfiguration of the network and associated components without disruption of service.
- Higher data rates will likely lead to more frequent transmission of time-sensitive data, such as audio and video files. Current standard data rates of 1 or 2 Mbps are far too slow for practical video transmission given that a multiuser LAN begins to saturate at an aggregate throughput of approximately 10 percent of rated speed. Also, transmission of large text or image files can cause congestion in a WLAN. WLAN data rates are quickly approaching 56 Mbps.
- Current WLANs can optionally apply low-grade data scrambling or basic encryption to the transmitted data. All the header information is frequently sent over the air in the clear. This causes weak traffic flow security, a problem that will be discussed in the Potential Attacks section below.
- If WLANs are to be used in a classified environment, individual node identity and message header information may be classified and thus will need to be protected at a higher level of security than presently available. This will require capabilities akin to the Network Encryption System (NES) or other robust encryption discussed in Section 5.3.5 of the IATF, but with a portable form factor.

### 5.2.3.3 Potential Attacks

A WLAN without appropriate security mechanisms in place can add critical vulnerabilities to a network, making it easy for an attacker to penetrate. With WLANs, an adversary no longer requires physical access to the network, as in a wired situation, in order to exploit a wireless system. This physical access is particularly important to an adversary in the case of VPNs and intranets, where physical access is required if those systems are properly established and protected in accordance with the IATF recommendations. Addition of a WLAN to a VPN or an intranet removes the physical access requirement for an adversary to penetrate the system.

#### 5.2.3.3.1 Passive

- Signal detection and intercept are readily accomplished with WLANs due to the limited requirements for diversity in spread-spectrum systems. The standards are public in IEEE 802.11, facilitating signal detection.
- WLAN signals are designed to penetrate office walls and to maintain user connectivity at significant distances—up to several hundred feet. Therefore, an attacker has the advantage of operating without requiring access to a protected facility, and the attacker can use high-gain antennas and receiver equipment to recover a signal. (Note that this is a major difference from a wired architecture. While some devices on a wired network may inadvertently radiate, they are not designed to do so. Cable shielding and the use of fiber-optic cable for network connections make it difficult for an adversary to tap on to a wired network without gaining access to the actual cabling.)
- A passive attacker can determine critical information about network architecture just by monitoring message headers, even if all the transmitted data has been encrypted. While this may be acceptable for government and some DoD applications, many government sensitive networks and military tactical networks would prefer not to divulge critical information about network nodes. Therefore, there is a clear requirement for inclusion of strong message confidentiality and good traffic flow security (packet header cover) in future WLAN designs.

#### 5.2.3.3.2 Active

- Attacks on a WLAN can be accomplished easily with the proper network analysis equipment. Standard network sniffers can be adapted to analyze wireless network packets. Current sniffer technology allows the sniffer software to be run from a laptop computer.
- Denial-of-service attacks, though not specifically network based, can have drastic effects on critical DII and NII networks if not properly detected. WLANs operate like any other radio in that the receiver must maintain an adequate signal-to-noise ratio in order to maintain a link. When the noise overpowers the signal and any processing gain, proper

reception will not happen. If an adversary decides to jam an access point or a major portion of the wireless network, the WLAN will not continue to function. However, this type of attack, and the source of the interference, would be easy to detect and correct. On the other hand, if an attacker directs a jamming signal at only one node, the rest of the network has no way of knowing why that node has gone down. In fact, many of the access points (i.e., wireless hubs) on the market today will continue to show a valid connection to that node even if it is currently unreachable. If a WLAN is used in a critical part of the NII, preventing denial-of-service attacks will be a major issue to address.

- Network information available to an adversary can lead to spoofing attacks using directional transmission aimed at the system RF hub or at a single node. The attack against a single node is more difficult to defend against because the RF hub would be unaware of the interference.

### 5.2.3.3.3 Insider

- An insider on a WLAN can often have access to access point configuration files. Without proper administrator authentication procedures at the access point, a user can modify these configuration files to increase the vulnerability of the entire network. For example, access points will usually only forward a message to their wireless nodes if the intended recipient is in that accessed point's domain. Thus, the wireless link is more efficient, and an attacker cannot easily view messages between nodes on the wired network. A malicious insider could modify the access point configuration to pass all or none of the network messages on to its nodes, if proper administrative authentication procedures are not in place.
- As on a wired network, many insider attacks are available in a WLAN. While user privileges can be set on a network server by the system administrator, there is no mechanism in place to prevent a legitimate user on the system from entering more private areas on the network. File privileges can be set on sensitive files, but if a privileged user wants to take advantage of a WLAN, there is no mechanism to prevent this. Again, this problem is not specific to wireless networks and was addressed in earlier sections of the framework.

### 5.2.3.3.4 Distribution

Hardware or software modification in transit could be used as a first step in a complete attack by which an adversary eventually could cause the system to send data or allow access by way of electronic connections to information for which he or she is not authorized. These attacks are more readily prevented using physical and operational security techniques and are not a primary emphasis in this section.

### 5.2.3.4 Potential Countermeasures

Many of the countermeasures used in a wired network, and those described in Section 5.3.4, Potential Countermeasures (for VPNs), also apply to the wireless case. In general, maintaining privacy is accomplished by appropriate use of confidentiality mechanisms. If a WLAN is employed in a classified application, the strength of confidentiality mechanisms must be sufficient to withstand national laboratory strength attacks.

As discussed in Section 5.2.3.3.1, traffic flow security is a major issue. Unfortunately, a WLAN cannot simply implement a constant bit rate leased line or other traffic shaping mechanisms. Leased lines in the wireless case do not apply, and traffic shaping may severely limit the throughput of the wireless link and interfere with the collision avoidance mechanisms in place. One way to provide some traffic flow security would be to route all wireless traffic through secure tunnels.

Wireless network sniffers used in conjunction with bit generators can be used to insert messages into a wireless network that appear to have originated in the network. Continuously authenticated channels can prevent insertion of information into the channel that can lead to short plaintext attacks that allow cryptanalysis by guessing known responses to known short messages.

Prevention of denial-of-service attacks on WLANs is a difficult issue, although, in some respects, the wireless case is very much the same as a denial-of-service attack on a wired network. Network administrators must implement proper authentication software to prevent the manipulation of network hardware. In the wireless case, simple signal detection mechanisms can probably detect and locate an obvious RF jamming signal as easily as an administrator on a wired network could detect a broad denial-of-service attack.

### 5.2.3.5 Technology Assessment

The technologies for WLANs are targeted at minimized bandwidth licensing requirements. Since users own their system infrastructure for WLANs, the low power and spread spectrum techniques that support nonlicensing of the spectrum are valuable to the user community. However, users, particularly government and DoD users, are cautioned that unlicensed bandwidth in the United States, e.g., 2.4 GHz band, may require licensing for use in foreign countries. Federal licensing authorities must be consulted on foreign requirements for bandwidth and spectrum allocation before systems are implemented in foreign countries.

FHSS and DSSS are both defined in IEEE 802.11 for WLAN applications, and both have been implemented by product vendors, but DSSS is the more popular implementation. Limited LPD is provided by the waveforms, but the 802.11 standard is sufficiently restricted in spreading patterns that such protection cannot be deemed suitable for military environments. The anti-jam (AJ) protection that is afforded is similarly weak for the same reason.

Current encryption and data scrambling methods used in WLANs provide minimal data protection and are not suitable for protection of classified information. The data encryption

techniques for commercial WLANs are insufficient for other than privacy. Presently, key lengths are restricted to 128 bits. The casual probe will not achieve access, but the strength of the cryptography will not withstand a more determined attack. Cryptography that provides security for transfer of header information is not in place and is not easy to implement. DoD products such as TAFLANE cryptography are available for high-grade protection of over-the-air signals. Development of PC card-based Type 1 security devices is also under study. The interfaces are complicated by use of such products because the commercial capabilities are meant to plug directly into processing elements. The DoD cryptography must be inserted between the processing and the transmission elements. The TAFLANE is transportable, but not man portable.

Operating frequencies vary according to product vendor and system. Presently, the 2.4 GHz band is the most popular; however, higher data rates are achieved with larger bandwidth in the 5.6 GHz range. It has been found in certain application environments that interference problems can occur. Notably, microwave ovens have been found to “jam” some WLAN systems. The RF technologies used in the GHz range communications systems include antennas that vary from 2–3 dB isotropic to directional gains in excess of 20 dB. In fixed plant configurations (or portable configurations that remain in one location during operation), the directional antennas can be used for nodes of a WLAN to increase range to a distance of several miles. Such nodes cannot then be highly mobile, since directional antennas must be aimed for effective operation.

Unfortunately, the same antennas can be used by an adversary to expand his or her probe range to a similar distance.

The wireless modem shown in Figure 5.2-4 provides the capabilities of a microwave transmission system at a small fraction of the cost. Such modems, as in the case of microwave links, can readily be equipped with over-the-air confidentiality applied to the modem point-to-point connection. Since the connection is point to point, and independent of protocol, there are straightforward solutions provided by commercial vendors and DoD to provide link encryption security at the requisite security levels.

### 5.2.3.6 Usage Cases

Other sections of this framework have addressed several cases involving connecting equipment at one classification level to equipment at the same or a different classification level across both trusted and untrusted networks. These cases are clearly an IATF issue and also apply in the WLAN domain. In general, some level of communications security is recommended for any equipment where there is a connection to a potentially hostile or unknown environment. In the case of wireless communications, all transmissions can be thought of as connecting to an unknown environment because of the nature of RF transmissions and the ease of signal intercept. Thus, the descriptions of each of the specific cases addressed in this framework remain unchanged for the wireless environment.

As mentioned previously, the type of network to which a WLAN is connected has substantial impact on vulnerabilities, attack approaches, and the damage that can be done. There are three interconnection possibilities in the scenario presented here for WLAN:

- Users connected to a stand-alone WLAN.
- Users connected to a WLAN that is interfaced to a wired VPN or intranet.
- Users connected to a WLAN that is connected to the Internet.

Figure 5.2-4 shows the three scenarios. The following security related elements apply:

- **Over-the-Air Exposure Exists.** Although spread-spectrum techniques are used, the spreading techniques are public and the signals are not difficult to intercept.
- **Detection Range of WLAN Signals Is Much Greater Than Communications Range.** Typical WLANs use small omnidirectional antennas. High-gain directional antennas can pick up signals at much greater ranges than those used for communications (the range can be several miles).
- **Information on Any WLAN Connected Network Is Exposed.** All communications on a WLAN are exposed to interception. Information on wired LANs to which the WLAN is connected is also exposed to interception. In the case of VPN or intranet connections, the protective mechanism of those networks may be defeated.
- **IP Headers Are Subject to Traffic Analysis.** The interception of IP traffic can compromise more than user data through the use of source/destination analysis.
- **WLAN Signals Can Be Spoofed.** Just as on the Internet, adversaries can use RF signal paths to masquerade as valid users or to deliver spurious messages.
- **WLANs Can Be Jammed.** Multiple jamming techniques exist for denying service to WLAN users.
- **Low Data Rates of WLAN Segment May Reduce Availability.** When a WLAN is connected to a high-speed wired LAN, WLAN users may experience reduced system availability and grade of service.
- **Service May Not Be Available in Mobile Systems.** If the WLAN network is developed using mobile components, nulls in signal may exist and users may periodically move out of range of other users or of network access points.

### 5.2.3.7 Framework Guidance

#### User Advisory

- As discussed in Section 6.2.6, Cases (Remote Access), top secret and compartmented information on wireless networks presents extreme risk and should be handled on a case-by-case basis.
- Do not assume that either the spread-spectrum techniques used or the short communications range of the WLAN components affords any protection against signal and data interception.

- Do not develop standard timing structures for transmissions. Asynchronous operations are preferred. Noise can alternate with real data.
- Use “ping” signals to test channel availability before commencing transmission.
- Do not process classified information on a WLAN without Type 1 encryption.

## Desired Security Solution

- Secure data and header information in sensitive transmissions.
- Provide intercept/low probability of detection (LPI/LPD) of WLAN transmissions for tactical situations.
- Protect wireless network against traffic flow analysis through RF transmission patterns.
- Continuously authenticate WLAN nodes to the “parent” system.

## Best Commercially Available Solution

- PC card/FORTEZZA<sup>®</sup> card software encryption of data prior to transmission.
- Most manufacturers use the 11-bit spreading codes called for in the IEEE 802.11 specifications. However, some manufacturers have modified the selection of spreading codes by implementing a way to select a different spreading code for each transmitted symbol. Thus, an additional level of transmission security is provided.
- The RF protocol, using direct spreading, is provided to increase bandwidth, make use of unlicensed spectrum, and increase the number of users that can be accommodated. The same technology also provides a degree of LPD protection.

## Technology Gaps

- Improved spreading and/or hopping characteristics of spread-spectrum transmissions could be implemented but are not accommodated in the standards.

## 5.2.4 Paging (One-Way and Two-Way)

Paging is defined as a broadcast or a duplex (that is, one-way or two-way) communication of short messages to highly mobile users in an area where system infrastructure is available for line-of-sight transmission of the messages. Paging was originally a one-way service provided over licensed channels for delivery of numeric messages. Today, paging can be one-way or two-way, so users may receive and send multiple types of short messages to and from their portable devices.

Paging can be accomplished over many networks, such as digital cellular, PCS, packet radio, and trunked radio. References to paging in this section apply to the transmission of many types of data over many types of system infrastructure depending on the facilities available to the service



## UNCLASSIFIED

Wireless Networks Security Framework  
IATF Release 3.1—September 2002

provider. Wireless communications providers have entered the paging market to enhance revenue for unused bandwidth in their cellular systems. Paging messages are broadcast when channels are tied up with circuit-switched cellular calls.

Pagers have gained widespread market penetration, and they are currently used by a large number of customers in the government, business, and personal environments. Although paging functions have been integrated into many types of mobile user systems (primarily cellular), paging is expected to exist as a stand-alone service well into the future because of the low cost of the service and the miniaturization of the user devices. Purely numeric paging will drop in usage, but bidirectional short-message service will take up the slack. One industry leader predicts a U.S. paging market of 70 million devices by the year 2005. However, there seems to be differing opinions on the future of pagers. Many now feel that devices, which only do paging, are declining and will continue to decline.

From a security and availability perspective, service provider advertising has not painted a totally accurate picture. Because each pager is identified by its own individual “cap code,” and the services are largely digital, there is a perception of message confidentiality. As presented in the news media, DoD and other federal government users have frequently become targets of pager attacks in the past. Paging is, in fact, a favorite “easy pickings” target of hackers. Primarily, the attacks have caused only embarrassment to the target organizations, but sensitive information has been involved in several cases (e.g., the location and plans of Secret Service personnel on a presidential protection mission in 1997).

In paging systems, message delivery is not guaranteed, but is largely reliable. Paging systems are designated as one way, 1.5-way, 1.75-way, and two-way. The intermediate numbers roughly describe the ability of the user device to respond to the messages and prompts. In general, the paging system does not know the location of a user, so the message is flood-routed to all areas in which the user has paid for service, thus increasing message exposure. Pagers above the one-way level are able to identify themselves to the system infrastructure so that the paging message is broadcast more selectively. The selective capability is increasing as more systems provide two-way paging. However, the basic low-cost service provided by most purely paging vendors is of the one-way variety. Battery lifetime is also a concern from an availability viewpoint; the more complex the device, the shorter the battery life.

### **5.2.4.1 Target Environment**

Pagers are used in a wide variety of environments, primarily personal and business, but also for urban police operations, emergency operation broadcasts, and even White House Secret Service communications. Two-way paging networks can be used by police in their vehicles for preliminary checks of criminal records or to perform quick driver’s license checks. Emergency operation broadcasts are used in both civilian and military environments to inform staff of the need to contact authorities. In these situations, guaranteed message delivery becomes critical, while security requirements will vary by users and particular situations. The following requirement list covers many different paging environments and will not apply to every situation.

A generalized environment for pager communications is shown in Figure 5.2-5. This environment is largely available in areas with high population density, since service providers wish to maximize the number of customers for a given (often sizable) system infrastructure investment. The figure represents cellular towers as the transmission mechanism, but this is not necessarily the case. Paging providers will often rent space for their transmitters on cellular towers (and cellular providers do use the cellular transmission media for paging), but pure paging systems use different transmitters and substantially higher power output due to the restriction of receiving sensitivity on miniaturized cellular receivers.

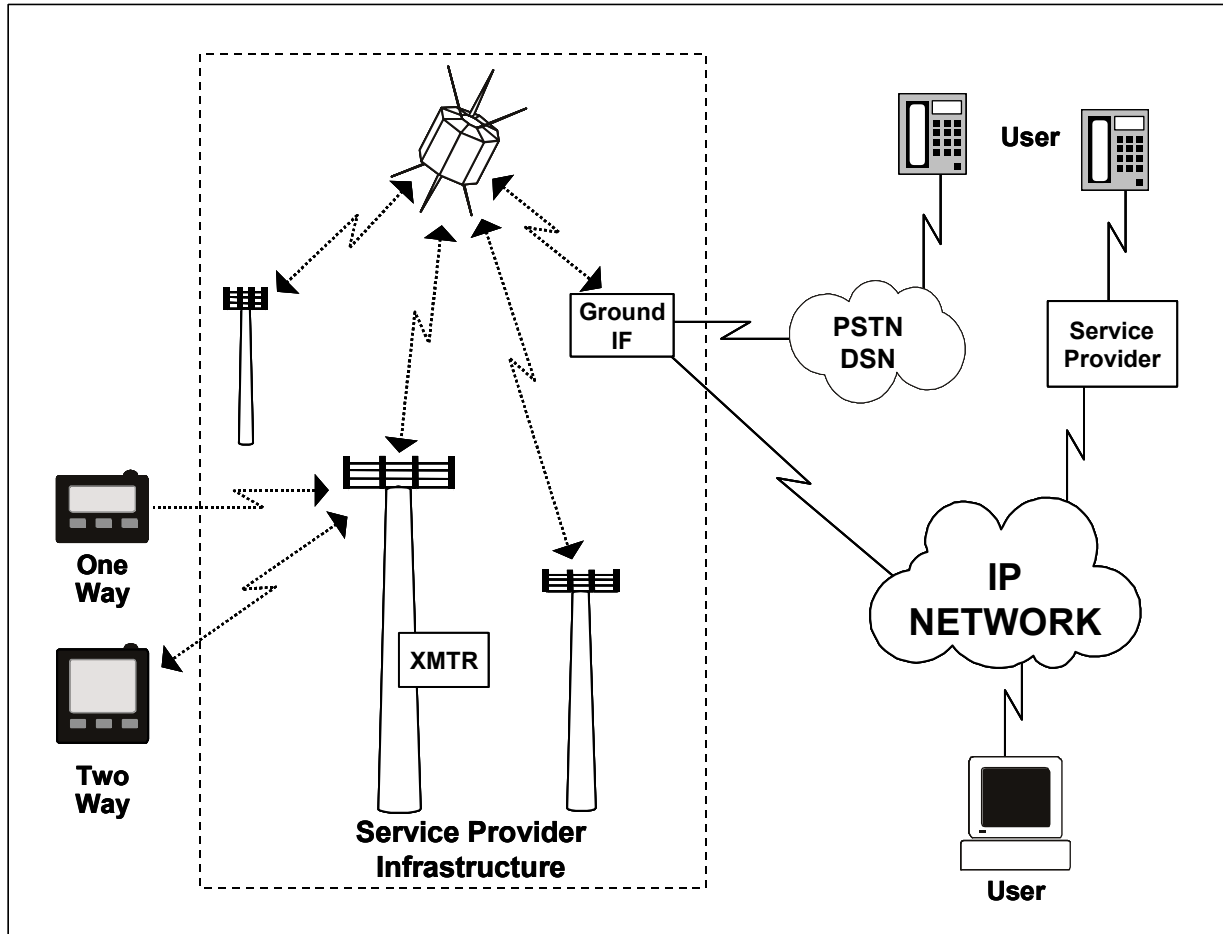

latf\_5\_2\_5\_0009

Figure 5.2-5. Pager Environment

## 5.2.4.2 Consolidated Requirements

The proposed requirements for paging operation are varied. The following list represents a consolidated set of functional capabilities that an advanced paging user would find useful.

### 5.2.4.2.1 Functional Requirements

- Receive telephone call-back (numeric) messages.
- Receive short text messages.
- Receive short voice messages similar to voice mail.
- Transmit short messages (numeric, text, and voice) (two-way paging).
- Provide message receipt verification to sender.
- Provide guaranteed delivery.
- Simulcast (reach multiple recipients with a single message).
- Provide confidentiality for message addresses.
- Provide confidentiality for message content over the air.
- Provide confidentiality for addresses and message content within service provider system.
- Provide indication of message receipt on mobile user device.

### 5.2.4.2.2 Networking Environments

- Both manual and automated interfaces (e.g., dial PIN and callback number) should be available at the service provider for numeric paging.
- Service providers require PSTN interfaces for message initiation.
- Various trunk (bulk transmission) media are required for distribution of messages to the over-the-air transmission sites. These can include leased satellite (as shown in Figure 5.2-5) or various land line or microwave systems (typically leased bulk data services where the provider is only concerned with delivery at the endpoints, and not the distribution path).
- The paging company/service provider requires an interface with the Internet for individuals to send messages to pager customers. Pagers interface with the Internet primarily to send and receive short messages and e-mail. Other Web services, such as traditional browsing and file transfer, are very costly because the user is charged by the number of characters downloaded every month. Pagers must maintain an emphasis on short messages to remain an affordable service.

### 5.2.4.2.3 Interoperability Requirements

- As paging technologies progress, older paging protocols are slowly decreasing in use. However, there is still a requirement for interoperability with older protocols like POCSAG.
- The Flex protocol has begun to dominate the market in the United States. Two-way paging protocols like the Motorola Reflex and Inflexion protocols are becoming de facto standards.

#### 5.2.4.2.4 Anticipated Future Requirements

- Provide confidentiality as a for-fee service element.
- Provide authentication of user to enable access to portable paging device.
- Provide authentication of message initiator.
- Increase message storage capacity of user paging devices.
- Provide interfaces with VPN.
- Provide over-the-air SMI capabilities to include user ID and key management to support confidentiality.
- Provide e-mail filtering and other message related applications.
- Provide interoperability with LEO satellite paging networks for global coverage.
- Provide interfaces to other user devices (e.g., palmtops, PCs) for message transfer and information synchronization.

#### 5.2.4.3 Potential Attacks

Pager users often do not consider the possibility that their communications might be intercepted by an eavesdropper. However, eavesdropping on pager traffic is relatively easy to do. Any individual with access to the Internet can download software and instructions on how to intercept pager traffic. Also, lists of pager cap codes, and often PINs, are published for all to see. There is a question of how sensitive the traffic sent over the paging network truly is. Traditional numeric paging simply alerts the paging customer to call a certain number. However, with the advent of text, message, and voice paging, more significant privacy and security concerns exist.

##### 5.2.4.3.1 Passive

- Intercepting pager traffic is readily accomplished, although illegal. Techniques, methods, and suggested equipment lists are posted on the Internet for any individual to read. Message traffic may be broadcast far beyond the area where the intended recipient is located due to the flood-routing algorithms used.
- Cap codes and PINs are often sent over the air to new users. An adversary can reprogram a second pager to receive all messages intended for a specific pager without being detected.

##### 5.2.4.3.2 Active

- E-mail and messages sent by Internet users are vulnerable to attack, as described in earlier sections of this IATF.

- Denial-of-service attacks through electronic jamming of the paging network in a localized area may go undetected by users.
- Spoofing techniques can be used by an adversary to send a message that appears to originate from a different location than it actually does. Without a way to validate message origin, recipients cannot be sure if they have received a valid message.

### **5.2.4.3.3 Insider**

- An insider is anyone having access to a paging service provider's database, customer personal account information, or paging equipment, whether or not this access is authorized by policy. These attacks could be motivated by deliberate malice or could be the result of unintentional mistakes on behalf of the user or service provider. Results of a deliberate attack can be especially damaging to the organization's information system due to the attacker's access to the information, his or her advantage in knowing the network's configuration, and thus the capability to exploit the network's vulnerabilities.
- A second type of insider attack involves theft of service or equipment by service provider representatives.

### **5.2.4.4 Potential Countermeasures**

- Users must be educated as to the capabilities and vulnerabilities of their pager service.
- Encryption methods can be provided for message confidentiality (net or public key).
- Authentication methods for both message initiators and recipients can be provided.
- Guarantee of delivery can be provided through use of 1.5-way, 1.75-way, and two-way paging techniques.
- AJ and LPI communications techniques can also be used.

### **5.2.4.5 Technology Assessment**

Since pagers are dependent on the RF media for message delivery, over-the-air confidentiality is a primary concern. Present packet structures for paging messages provide very little message bandwidth (on the order of dozens of bytes for older systems and hundreds of bytes for advanced paging systems). Additionally, most providers charge for their service by the byte delivered. The narrow available bandwidth creates difficulty with the overhead that is introduced for secure message delivery. Such overhead includes key distribution, synchronization, and reformatting of messages, e.g., Uencoding, for delivery over packetized networks. New technologies are continually increasing the bandwidth available to pager systems, so overhead concerns will be reduced.

One vendor has developed a pager security technique that employs over-the-air encryption and firewall wired network access. Although promising, the technique does not provide confidentiality in parts of the service provider system infrastructure.

Pagers presently have minimal storage and programming capacity to support security mechanisms. Hand held computers and cellular phones that can be programmed or provided with ancillary devices, e.g., PC cards, to provide paging service are candidates for insertion of security mechanisms, but these devices do not fit into the miniature device pager-only scenario.

Guaranteed message delivery remains an issue when a return path is not available. However, procedural methods like telephone callback can be implemented to give assurance of message receipt. In fact, telephones can be busy, and e-mails may not be delivered, so the pager scenario is not necessarily of lower assurance than other message delivery mechanisms. If message assurance is required, then two-way paging techniques can be employed at higher costs than those for one-way service.

The interfaces provided with pager devices are minimal at this point, primarily due to cost and size considerations. Offline security measures (authentication, encryption) can be considered if interfaces are provided for elements such as smart cards or CompactFlash cards. New standards for RF interfaces with miniature devices, e.g., Bluetooth, could more readily support security services.

## 5.2.4.6 Usage Cases

The usage cases for paging involve several different configurations, as shown in Figure 5.2-5. The potential use of the Internet, VPNs, or other IP-based network types in the scenario results in vulnerabilities discussed in other sections of this document in dealing with the wired network systems and system infrastructure. However, unlike the WLAN situation, the use of pagers with network connections does not necessarily increase vulnerabilities of the wired network. Pages are sent using a set of pager-unique protocols rather than IP protocols. Thus the exposure of the IP network is not as great as it would be with a WLAN connection.

As shown in Figure 5.2-5, there are three different access methods for initiation of the pager message:

- Sending party uses Internet to reach service provider.
- Sending party uses standard telephone call to reach service provider.
- Sending party uses cellular telephone to reach service provider.

The page message can be delivered under several scenarios that are service and service provider specific.

- One-way page with no response from the recipient.
- 1.5-way or 1.75-way page with limited response to the provider system from the message recipient.

- Two-way page where specific full message can be developed in response to the pager message.

When employing a pager system for sensitive and important messages, the mobile user must be aware of the characteristics of pager transmission.

- **Over-the-Air Interception of Pager Signals Has a Broad Range.** Since pager signals are broadcast to the entire coverage area of a pager system, an adversary can intercept messages from anywhere in the pager coverage area. The requirements for interception are trivial and available on many hacker Web pages. Also, in one-way paging systems, messages are broadcast multiple times to increase probability of delivery.
- **All Pager Messages Pass Through an Insecure Provider Network.** The provider may be telco connected, or connected through the Internet.
- **Message Delivery Is Often Not Guaranteed.** One-way pagers do not assure delivery, or at least do not inform the message sender that the page was not delivered.
- **Messages Can Be Stored in Low Security Environments.** Some providers will store messages for later repeated transmission if acknowledgments are not received.

## 5.2.4.7 Framework Guidance

### User Advisory

- Pagers have all of the vulnerabilities associated with over-the-air transmission, but the area of exposure is much greater due to transmission throughout the pager system.
- If reliability of pager message delivery is required, use at least a 1.5-way pager that gives a message acknowledging receipt of message. The one-way pager has no way to report message receipt.
- Digital pagers are somewhat less susceptible to attack than analog systems, but both are vulnerable to interception.
- Use the briefest message format possible. In terms of content, a numeric pager that requires a call-back is preferable to sending full messages on an alphanumeric system if the messages are not encrypted.
- Use of a standard wired telephone is preferable to the use of the Internet or a cellular phone for delivering messages to the service provider.
- At least one service provider (a team of SkyTel and V-One) provides an encryption service for over-the-air transmissions. The solution is better than no over-the-air security, but some exposure still exists within the service provider network and Internet connections.

## Desired Security Solution

- DII and certain NII customers require a higher degree of security in their pager network than is currently available. Sensitive information transmitted across a pager network should be encrypted on an end-to-end basis. This will require encryption capabilities at user terminals (i.e., the pagers). Reduced security involving over-the-air security only for message content and addressing will be suitable for privacy applications on a case-by-case basis.
- Authentication of sending party and acknowledgment of receipt are desirable characteristics.

## Best Commercially Available Solution

- Vendor solutions exist for provision of privacy-level encryption using more advanced programmable user paging devices, thus establishing a VPN environment for pager customers. However, the messages must be decrypted within the service provider network for routing purposes.
- If guaranteed delivery (or at least verification of delivery when it occurs) is a requirement, then a service provider must be selected that provides capabilities beyond the basic one-way paging systems.
- The recently announced provision of an elliptic curve public key cryptography key delivery system may assist in reducing the bandwidth overhead associated with Key Management Infrastructure functions.

## Technology Gaps

- End-to-end encryption capability with minimal overhead encoding schemes.
- Short form rekey and SMI technology for authentication and key distribution.

## 5.2.5 Wireless Local Loop/Wireless Public Branch Exchange/Cordless Telephones

Section 5.2.1 of this framework discussed a wireless telephone environment where a user with a hand-held telephone roams throughout a cell structure controlled by a cellular service provider. This section describes a similar environment, but on a much smaller scale, using what could be called a microcell or enclave structure. This section on wireless telephony defines a set of technologies and services that connect users to the wired circuit-switched telephone network using local low-power RF paths.



## UNCLASSIFIED

Wireless Networks Security Framework  
IATF Release 3.1—September 2002

The three technologies in this section have been grouped together because of the similarities in their target environments, use of technology, and protocols. WLLs can provide telephone service to remote areas where a wired infrastructure does not exist or can serve for reconstitution of communications when the wired infrastructure is damaged. Future deployment scenarios for DoD foresee the use of wireless PBXs and cordless telephone equipment in remote areas or in tactical situations. The environment and range for the wireless PBX case are very similar to those for the WLAN.

A WLL can be described as a wireless replacement for the connection between the Central Office (CO) and user switching equipment. WLLs are often used to provide telephone service to areas where laying cable is not practical because of terrain, or in remote areas where a microwave link or wireless modem is faster and easier to set up than a wired link to the CO. A typical configuration provides microcell concentrators within the local WLL service area with the RF links described above providing CO connection.

Wireless PBXs are often used in offices or manufacturing plants where individuals require mobility. A wireless PBX sets up a microcell structure where individuals carry a portable handset with them whenever they are away from their desk. Incoming calls are routed by the PBX first to users' desktop phones, then to their portable phones. In essence, the portable phone is just an extension of the desktop phone that can be used from anywhere in the site within microcell range. This setup is used frequently in applications like hospitals and large manufacturing plants. The ability to handle high user densities is what distinguishes a wireless PBX cell structure from the cellular phone system described in Section 5.2.1, Cellular Telephone.

Cordless phones are the most common of these three devices, used primarily in a household or neighborhood environment. Unlike the handset used with a wireless PBX, a cordless phone is used simply as a replacement for the standard desktop telephone. Each base station interacts with a single handset. The phones also have very limited range, typically under 150 feet, but the range is expanding as new products are introduced.

### 5.2.5.1 Target Environment

Commercial application of the WLL is primarily envisioned for third-world areas or remote locations where a wired infrastructure does not exist. In government applications, a wireless PBX could be used by military personnel as a field tactical telephone system that does not require stringing of wires, or even as replacement for elements of the TRI-TAC system. Both WLL and wireless PBX systems can help forces restore sufficient telephone service to stay connected to a main operating base in the event of loss of wired communications capability as long as the forces and the main operating base are in relatively close proximity or within line of sight using wireless modem interconnection. Many other applications exist within the standard office environment for DII and NII customers, especially where other data networks interface with the wireless system in use. Security requirements in these systems vary based on the threat in the local area. Sensitivity of communications, the need for reliability, and the amount of controlled space around an area using a wireless PBX or a cordless phone will help determine the

specific threat to the user. A WLL provides for RF connections over a much larger physical area than the wireless PBX or cordless phone.

Figure 5.2-6 shows an example of how a wireless PBX and WLL could be deployed to provide telephone access in different situations. The WLL case uses a service provider system infrastructure, while the wireless PBX has a user-owned system infrastructure (again similar to the WLAN).

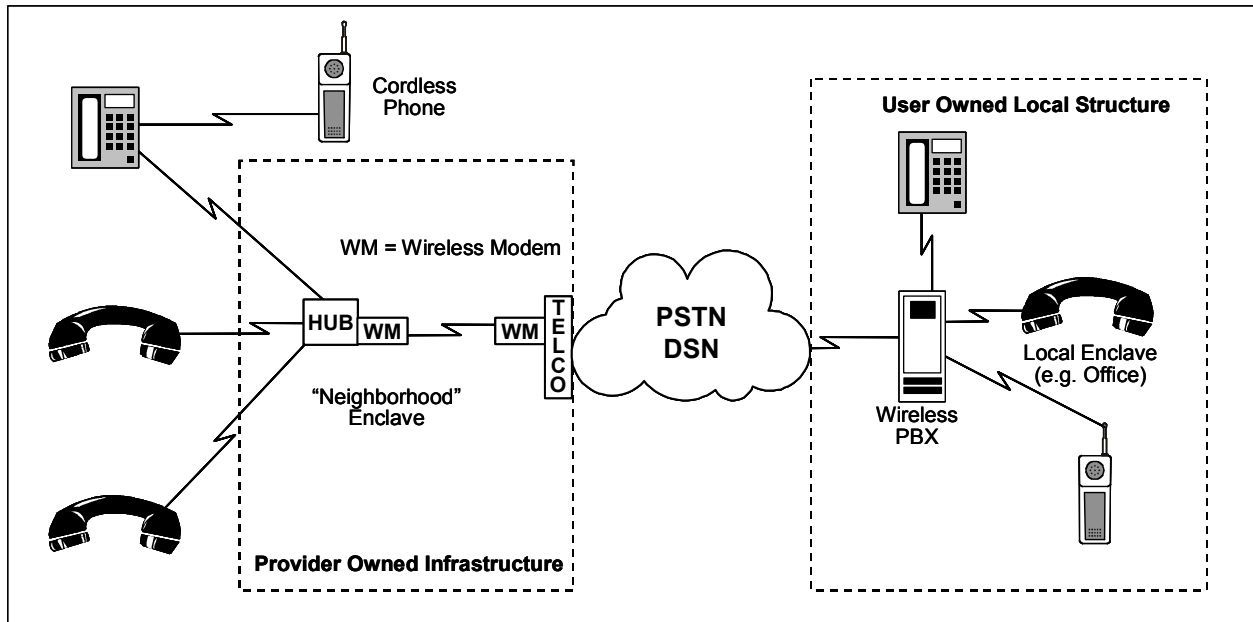

iatf\_5\_2\_6\_0010

Figure 5.2-6. Wireless Telephony Environments

## 5.2.5.2 Consolidated Requirements

### 5.2.5.2.1 Functional Requirements

Users/User Equipment (PBX and Cordless)

- Users must be able to make and receive dialed calls within the range of the system.
- Users must be provided with the standard features of wired telephony.
- Reliability and availability of service should be no worse than for wired system.
- Users and handsets must have assigned ID numbers.
- Handsets must be portable.

- Security of both control channel and user information channel information must be assured. The link between handset and base station must be at least as secure as the traditional wired telephone link.
- Confidentiality of user information on the “talk” channel is required.
- Confidentiality of keypad information should be provided. This function would secure credit card transactions, PINs, and other account numbers that are entered on telephone keypads.
- Confidentiality of signaling and call setup information is desired.

### **5.2.5.2.2 Networking Environments**

Converge mobile and fixed wireless capabilities into one flexible hybrid network.

### **5.2.5.2.3 Interoperability Requirements**

Wireless PBX and cordless telephone handsets should ideally be compatible with cellular telephone infrastructure.

### **5.2.5.2.4 Anticipated Future Requirements**

- In addition to telephone services, WLL will also be used to provide Internet and intranet access to distant locations at Integrated Services Digital Network (ISDN) data rates at a minimum.
- Militarized versions of commercial systems will provide end-to-end Type 1 confidentiality, call authentication, and jam resistance.

## **5.2.5.3 Potential Attacks**

### **5.2.5.3.1 Passive**

- WLL signals will typically traverse long distances on the reachback to the wired infrastructure using microwave or wireless modem systems. The signals pass across potentially hostile areas, providing easy access for an adversary.
- Wireless PBX and cordless communications have similar vulnerabilities to those discussed in the section on cellular communications. Both voice and control channel information is vulnerable to interception, although the intercept range is smaller with wireless PBX and cordless systems.

### **5.2.5.3.2 Active**

- System administration for WLL and wireless PBX is typically done on a PC at the user location. System administrator functions can also be performed from remote locations through an Internet or dial-in connection. In this situation, all administrator functions are vulnerable to attack from any network around the globe. Therefore, sufficient protections must be in place to prevent unauthorized individuals from accessing the system.
- Denial-of-service attacks through electronic jamming, while easily detectable with the proper monitoring equipment, can have disastrous effects in emergency or battlefield situations.
- Spoofing attacks through changes in dialing or transmission of false messages are possible.

### **5.2.5.3.3 Insider**

- Modify cordless handsets.
- Change user privileges in system administration database.
- Adjust output power control in microcells.

## **5.2.5.4 Potential Countermeasures**

Several techniques are available to provide bulk encryption for WLL signals on the reachback (to the wired infrastructure) channels. Because of the high power and long distances covered with typical WLL installations, it is difficult to control where the signal radiates. Therefore, some method for encrypting this link is essential. Standard link encryption technologies (protocol independent) can serve the purpose.

For wireless PBX and cordless telephone channels, handsets and base stations can be equipped with a crypto token or smart card device to provide security between the handset and the base station. At a minimum, some sort of data scrambling or spread-spectrum modulation technique must be used to ensure that the wireless link is at least as secure as a traditional wired telephone link. Spread-spectrum techniques can also provide increased resistance to electronic jamming. Addition of a software or hardware token could be used to provide the data confidentiality and I&A required for more sensitive transmissions.

## **5.2.5.5 Technology Assessment**

Several manufacturers provide WLL and wireless PBX solutions today that implement all the common telephony functions, including call waiting, call forwarding, three-way calling, and voice mail. Most of these systems are designed for the office environment and provide security features comparable to those found in cellular phone networks. Unlike cellular phone technology in the United States, wireless PBX systems primarily use one signaling protocol,

Digital Enhanced Cordless Telecommunications (DECT). DECT began as a cordless phone protocol and is now used in the United States and Europe for both cordless phones and wireless PBXs. In addition to DECT, some cordless telephones use other signaling protocols like CT-1 and CT-2. The Personal Handyphone System (PHS) is a protocol used primarily in Japan and other Asian markets.

WLL systems are still in the early stages of market deployment. As the number of products on the market increase, and users in the DII become aware of the benefits of WLL and wireless PBX systems in previously unwired urban environments, more frequent deployments of these systems will occur.

### **5.2.5.6 Usage Cases**

Other sections of this framework have addressed several cases involving connecting equipment at one classification level to equipment at the same or a different classification level across both trusted and untrusted networks. These cases are clearly an IATF issue and also apply in the wireless domain. However, use of wireless equipment interfacing with a wired network does not significantly change the cases that were previously discussed. In general, some level of communications security is recommended for any equipment where there is a connection to a potentially hostile or unknown environment. In the case of wireless communications, all transmissions can be thought of as connecting to an unknown environment because of the nature of RF transmissions and the ease of signal intercept. Thus, the descriptions of each of the specific cases addressed in this framework remain unchanged for the wireless environment. Wireless telephony calls are treated herein as system High connections to their environment.

### **5.2.5.7 Framework Guidance**

#### **Desired Security Solution**

- At a minimum for NII and DII applications, the wireless equipment must provide data security equivalent to the security provided on a wired link. Basic analog or digital modulation of a voice signal without any data scrambling or spread-spectrum modulation makes wireless transmissions easy targets for interception.
- For sensitive data, these wireless telephone systems must provide the capability to use appropriate encryption techniques for the level of information being transmitted. Implementation using hardware or software tokens for user handsets is a possible solution.

#### **Best Commercially Available Solution**

As discussed in the section on cellular telephony, the best current solutions involve using a user-carried installable token (e.g., akin to the SIM card) with a cellular GSM or PCS phone to provide user I&A. Some cellular telephones provide wireless PBX and cordless telephone handset connectivity.

## Technology Gaps

- Other than the minimal privacy provided by digital transmission of voice signals over the air, very few currently available systems provide any degree of data confidentiality or data integrity. User tokens or SIM cards could help provide user authentication and data confidentiality for cordless telephones and wireless PBXs between the handset and the base station.
- In such an obvious military application, the capability to provide ruggedized components and high-grade security is needed.

**UNCLASSIFIED**

Wireless Networks Security Framework  
IATF Release 3.1—September 2002

**This page intentionally left blank.**

## 5.3 System-High Interconnections and Virtual Private Networks

Many new options opened in recent years for providing alternative security mechanisms for protecting DoD information systems. Receiving justifiable attention are application layer mechanisms that offer end-system-to-end-system security services with stronger binding of the end user to applications than has been possible with simple password mechanisms. The problem has been that although the promise of application layer security has been very high, realization of all the benefits has been difficult. That difficulty arises from the fact that most computer platforms use operating systems that offer only minimal trust mechanisms if any at all. Since these untrusted operating systems control the computer platform resources, malicious elements of such operating systems could affect the invocation of the application layer trust mechanisms in ways that defeat the desired information assurance outcome. Moreover, the platform responds to network port operations in software processes outside the control of the higher layer security mechanisms, leaving the platform open to network attacks.

The response to this lack of strong invocation and lack of protection of the network port is that invocation of security mechanisms must be checked outside the end system. Furthermore, this checker must be the gatekeeper for whatever is allowed to pass to the end system. This gatekeeper has recently taken the form of an application layer guard that implements firewall mechanisms while performing an invocation check on all information allowed outside the protected enclave. This guard, while effective for non-real-time applications on networks with low sensitivity, has been difficult to scale to highly classified networks and real-time mechanisms. This difficulty, along with growth in the use of commercial networks by private industry, has created a renewed interest in efficiently using security mechanisms to create an effectively private network across a public backbone. This is not a new strategy for DoD. However, the renewed vigor in the pursuit of such solutions is recent. This section outlines the options available for implementing virtual private networks (VPN) and gives sufficient information to trade off the options.

Before the wide dissemination of Internet technology, networking between separate parts of an organization required a privately owned system of communications lines or leased fixed telecommunications services connecting the various entities. The number of techniques for providing communications between facilities has increased dramatically. While leasing telecommunications lines is still an option for those with specialized communications environments, there are many more cost-effective options. All major telecommunications vendors offer an on-demand virtual network service based on narrowband Integrated Services Digital Network (ISDN), frame relay, or Switched Multi-megabit Data Service (SMDS). Some vendors offer higher data rate services based on asynchronous transfer mode (ATM) technology. Some organizations are using connections over the Internet. With all of these communication methods comes some risk of exposing private information to outsiders. Each method offers varying degrees of risk and differing amounts of protection used to mitigate the risks. The purpose of this section is to explore the possibilities and to offer guidance on how information should be protected in transit across these networks.



Some overlap is expected between the options presented here and in other portions of the IATF. This is particularly true for remote access of classified networks by lone users, and for high-to-low interconnect. This overlap occurs because the various forms of networking discussed here are not unique. The particular end achieved is the result of a particular implementation of the underlying techniques.

One note on terminology. Throughout this section, the term “Type 1” strength cryptography is used. Traditionally this has meant government-developed or -sponsored equipment containing security mechanisms that meet some minimum strength of implementation used where enough assurance mechanisms were in place to eliminate compromising failures. In the context that it is used here, it is generalized to include equipment from any source, provided that robust minimums of cryptographic strength and assurance mechanisms are included in the design. The exact definition of what these assurances and strengths must be is beyond the scope of this document.

### 5.3.1 Target Environment

A VPN allows the use of a public communications infrastructure in such a manner to exclude all entities outside a defined community. The communications may consist of leased lines, dial-up service, packet and cell switched connection-oriented networks, and or routed connectionless networks.

Figure 5.3-1 is deliberately vague about the type of communication infrastructure being used because a variety of infrastructures are possible.

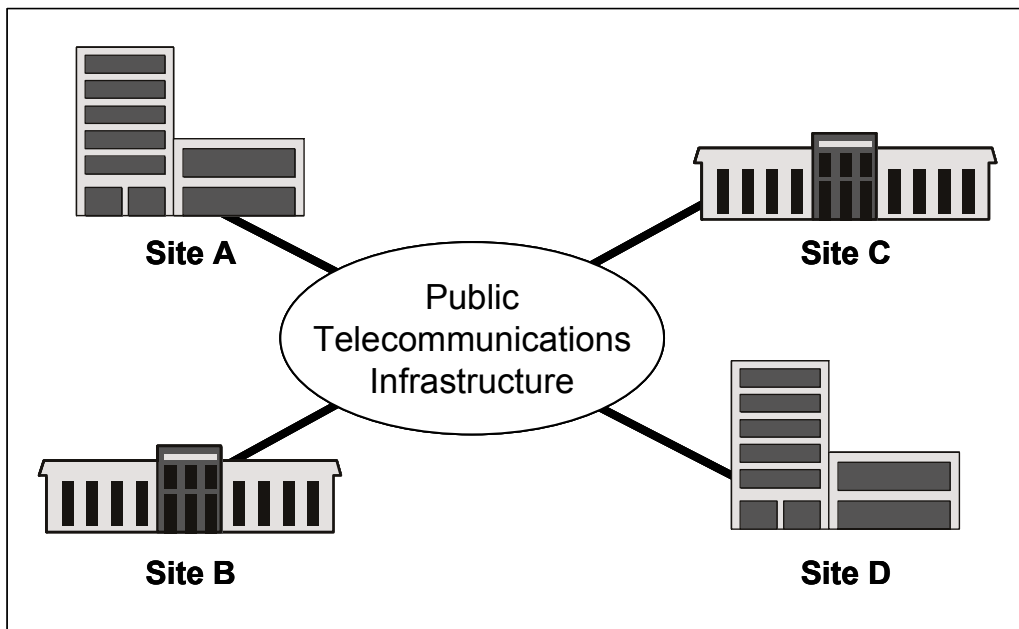

iattf\_5\_3\_1\_0012

Figure 5.3-1. Target Environment Communications Infrastructure

**UNCLASSIFIED**

For example, the following infrastructures are among those available today:

- If the service is switched and connection-oriented, it can be frame relay or ATM.
- If it is dial-up service, it can be based on ISDN or digital subscriber line (DSL).
- If it is packet-switched and connectionless, it can be Internet or SMDS.
- If the service is leased line, it can be Digital Service, Level Zero (DS-0), DS-1, Fractional DS-1, Burstable T-1, DS-3, Synchronous Service Transport, Level Three (SST-3), or higher rates in North America. Table 5.3-1 provides additional information for each these.

**Table 5.3-1. Digital Service Standards**

Digital Standards	Definition
DS-0	In the digital hierarchy, this signaling standard defines a transmission speed of 64 Kbps. This is the worldwide standard speed for digitizing one voice conversation; (i.e., converting one analog voice channel into a digital signal. It is derived from using pulse code modulation (PCM) and sampling the voice channel 8,000 times a second. This signal is then encoded using an 8-bit code. Thus, 64,000 bps is derived from 8-bits times 8,000 times per second.
DS-1	In the digital hierarchy, this signaling standard defines a transmission speed of 1.544 Mbps. A DS-1 signal is composed of 24 DS-0 channels. DS-1 is often used interchangeably with T-1, which is the U.S. equivalent of E-1. T-1 is a Bell system term for a digital carrier facility used for transmission of data through the telephone hierarchy at a transmission of 1.544 Mbps. E-1 is the European equivalent of a T-1 circuit. E-1 is a term for digital facility used for transmitting data over a telephone network at 2.048 Mbps.
Fractional DS-1	A DS-1 circuit in which a fraction of the 24 DS-0 channels are used; (i.e., between 64 Kbps and 1.536 Kbps. If a full DS-1 circuit is 24 DS-0 channels at 1.544 Mbps, a $\frac{1}{8}$ fractional DS-1 is four DS-0 channels at 256 Kbps, a $\frac{1}{2}$ fractional DS-1 is 12 DS-0 channels at 768 Kbps and $\frac{2}{3}$ fractional DS-1 is 16 DS-0 channels at 1,024 Kbps.
Burstable T1	This service is a billing scheme. It is an unshared, non-fractional T-1 line running at 1.544 Mbps. While a DS-1/T-1 customer has the full capacity of the line (24 DS-0 channels at 1.544 Mbps) any time it is needed, the customer is billed only an average usage computed from periodic samplings of the input and output data rates on the link.
DS-3	In the digital hierarchy, this signaling standard defines a transmission speed of 44,736 Mbps. A DS-3 signal is composed of 673 DS-0 channels. DS-3 is often used interchangeably with T-3, which is the U.S. equivalent of E-3. T-3 is a Bell system term for a digital carrier facility used for transmission of data through the telephone hierarchy at a transmission rate of 45 Mbps. E-3 is the European equivalent of a T-3 circuit. E-3 is a term for a digital facility used for transmitting data over a telephone network at 34 Mbps. Also available is a fractional DS-3 service in which a fraction of the 28 DS-1 channels are used; i.e., between 1.544 Mbps and 43,232 Mbps. Other digital service levels are available; e.g., DS-2, 96 DS-0 channels at 6,312 Mbps; DS-4, 4,032 DS-0 channels at 274,760 Mbps.

UNCLASSIFIED

Digital Standards	Definition
SST	This is a SONET-based, private line transport product that offers high-capacity channels for synchronous transmission at transport line rate from 155.52 Mbps to 2,488 Gbps. It enables the interfacing of asynchronous networks with synchronous networks.
DSL	<p>DSLs are point-to-point public network access technologies that allow multiple forms of data, voice, and video to be carried over twisted-pair copper wire on the local loop between a network service provider's central office and the customer site. Included are asymmetric digital subscriber line (ADSL), rate-adaptive digital subscriber line (R-ADSL), high bit-rate digital subscriber line (HDSL), single-line digital subscriber line (SDLS), and very high bit-rate digital subscriber line (VDSL). Collectively, the DSL technologies often are referred to as xDSL. ADSL is an xDSL technology that allows more bandwidth downstream—from a network service provider's central office to the customer site—than upstream from the subscriber to the central office. ADSL is ideal for Internet/intranet surfing, video-on-demand, and remote LAN accesses. R-ADSL is an xDSL technology that adjusts dynamically to varying lengths and qualities of twisted-pair local access lines. R-ADSL makes it possible to connect over different lines at varying speeds. HDSL is an xDSL technology that is symmetric, providing the same amount of bandwidth both upstream and downstream. Due to its speed—1.544 Mbps over two copper pairs and 2.048 Mbps over three copper pairs—TELCOs commonly deploy HDSL as an alternative to repeated T-1/E-1 lines. SDLS is an xDSL technology that provides the subscriber only one DSL line. VDSL is the fastest xDSL technology, supporting a downstream rate of 13 to 52 Mbps and an upstream rate of 1.5 to 2.3 Mbps over a single copper-pair wire. Maximum operating distance for this asymmetric technology is 1,000 to 4,500 feet. The VDSL bandwidth could potentially enable network service providers to deliver high-definition television signals in the future.</p> <p>Note: TELCO is a generic term for local telephone company operations in a given area.</p>

No matter what the underlying communications scheme, the desired result is to connect separate pieces of a larger organization in a manner that provides unimpeded communications between the pieces of the organization, denies access to the information within the pieces by any outside organization, and provides for the privacy of information as it traverses the public infrastructure.

Many people make the assumption that a VPN is a distributed enterprise network connected across a public Internet but separated from that Internet by an encrypting firewall. This use of the term precedes the definition of Internet Protocol Security (IPSec) that is the basis of the present generation of encrypting firewalls. The three major telecommunications carriers offer a virtual private networking service that combines voice and data features, billing, access, screening, and rerouting capabilities but does not have any inherent encryption mechanism.[1] This chapter uses a broader definition of VPN that encompasses any means of using public communications infrastructure to manifest an apparently private network.

In the context of this IATF, there is little difference between a system-high interconnect and a VPN. Possibly the only real difference is that the end systems have implemented a private network with an wholly owned infrastructure or the end systems use a shared backbone based on some publicly offered service. Although some state that use of a provisioned service like DS-3 or Synchronous Optical NETwork (SONET) is a system-high interconnect, these services are

multiplexed onto a public backbone, managed by a public entity, and the routes can slowly change in response to some network conditions. Therefore, even this type of networking represents the creation of a VPN across a public switched backbone.

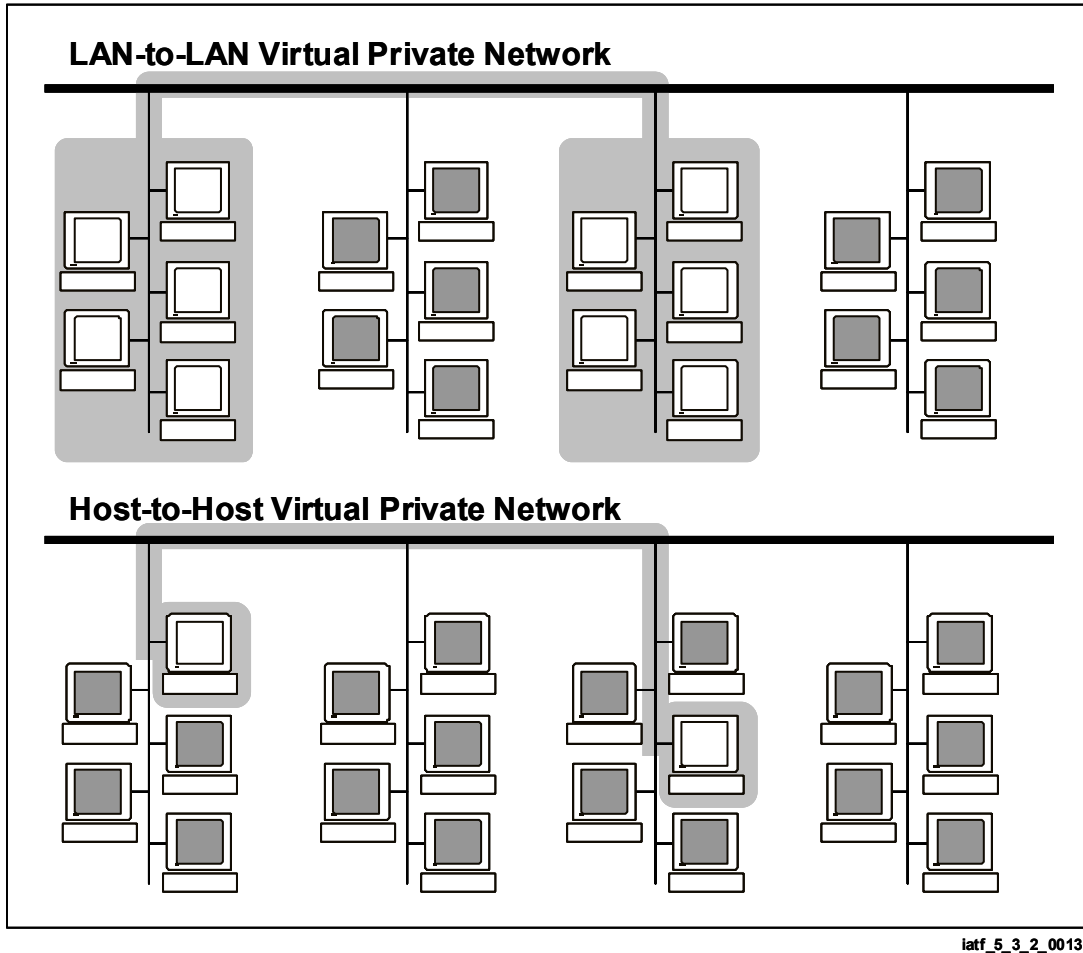

Figure 5.3-2. Local Virtual Private Network Architectures

## 5.3.2 Consolidated Requirements

The present requirements are derived from operating scenarios of present system-high networks based on use of leased line services and on an interconnect model that uses the Internet.

Anticipated requirements are derived from plans for the far-term Defense Information Systems Network (DISN), technology developments from Defense Advanced Research Projects Agency (DARPA) and the Global Grid community, plans stated by telecommunications vendors, and aggressive research and development (R&D) networks such as those pursued under the Nuclear Stewardship Program.

### 5.3.2.1 Functional Requirements

Near-term functional requirements are as follows:

- Must support connection of separated entities across public infrastructures (site-to-site model) or within private facilities (Local Area Network [LAN]-to-LAN or host-to-host model).
- Must support classified operations or unclassified operations.
- Must support standards-based network operations.
- Must keep network information confidential and integral while in transit.
- Must prevent entities outside the private facilities from gaining access to those facilities.
- Must use techniques that support scalable communications rates from kilobit per second rates to OC-192 (10 Gbps) and beyond.
- Must transport primarily data including voice, video, imagery, and data.
- Must optionally provide data integrity.

Mid- to far-term functional requirements are as follows:

- Must support quality of service in the telecommunications being supported.
- Must support data rates for specialized applications that exceed 13 Gbps by the middle of the next decade.
- Must support information that is mixed voice, video, and data.
- Must connect nonuniform security policies. As more risk management philosophies are developed for administering security within network domains, security policies can be expected to diversify even within similar classification levels of networks. These discrepancies will result in additional security requirements on VPN architectures.

### 5.3.2.2 Networking Environments

This section serves as a local reference regarding environments in the context of the virtual private networking arena.

Two networking environments are currently dominant. The first is link layer connection over leased lines and the second is Internet Protocol (IP) packet routing over the Internet or ATM wide area networks. Although frame relay and SMDS technologies have made significant inroads into the business community, they have been used rarely for classified communications. This has been attributed in part to the lack of native mode security systems for these means of

communication but also because there have been alternative means of achieving security services that could be used without affecting the functionality of the network.

Networking environments will undergo drastic changes over the next few years. With this revolution will come an explosion in the number of networking technologies. Although the IP and provision networks of today will not disappear, they will be joined by newer technologies and by variations of the old technologies. The present IP version 4 will evolve to incorporate bandwidth reservation schemes in an attempt to add quality of service attributes to deliver business-quality voice and video applications over the Internet. Other users will move to ATM networks because they are designed to deliver quality of service for these same applications. A war for market share will ensue between these networking technologies. The outcome of this battle is not clear. Currently, neither technology fully achieves all of its promises. The expected result will likely be a coexistence of these technologies.

As wireless network technologies evolve, there is likely to be a specialization of IP for the mobile environment that will require some level of gateway to the wired portion of the Internet.

Speeds of connectivity will increase. The maximum available today in a standardized format is an STS-48/STM-16 signal at 2.5 Gbps and some initial deployment of an STS-192/STM-48 signal at 10 Gbps. These signals will be wavelength division multiplexed up to 40 and 80 Gbps. The affordability of such large bandwidths is certainly a major issue. However, a few programs have identified communications requirements of greater than 10 Gb/s. The most easily referenced example is Department of Energy's (DOE) Nuclear Stewardship Program. To support simulations of aging effects in stockpiled nuclear weapons, it is estimated that computational capacities of 0.1 Petaflops are required, backed by 13 Gbps communications between the DOE weapons laboratories.

### **5.3.2.3 Interoperability**

A trend within the DoD is to break down barriers to connectivity rather than put more barriers in place. As a result, the natural segregation that would occur between entities in different communications environments, between entities communicating at different rates, and between those entities using different networking architectures is breaking down. Therefore, one must assume that a secure means of exchanging information between the various networking architectures is required.

Another interoperability issue is the DoD trend toward breaking down barriers between networks operating at different levels of classification and assurance. Although, this is a multilevel security problem and not a virtual private networking issue, the solutions must be mutually supportive.

### **5.3.3 Potential Attacks**

The attacks listed here are those primarily of concern to systems protected at network layers and below. One interesting paper, although written primarily about a particular implementation of

IP-based security, presents an open tutorial of many issues that must be considered when implementing network layer security solutions. [1] Although, the author often assumes that an adversary already has access to a private resource and therefore presents a pessimistic picture, the subject matter at least considers many security issues that are often ignored. This paper is used as a reference throughout this section.

Attacks against networks vary greatly regarding the techniques and results. While some try only to uncover private information, others try to disrupt operations, disseminate misinformation, and gain access to resources.

### 5.3.3.1 Passive Attacks

The primary concern with passive intercept attacks is the loss of information confidentiality while in transit across the network. Basic privacy rules to prevent inadvertent disclosure are insufficient for DoD. Recent reports show that cryptanalytic capability is available in the public domain as witnessed by the June 1997 collaborative breaking of the 56-bit strength Data Encryption Standard (DES). Although, the near-term threat to large volumes of traffic is questionable given the number of machines and hours involved, it does show the vulnerability of any single transaction. Therefore confidentiality mechanisms must pass some measure of minimum strength to be acceptable. However, that is not the only concern. Some military operations require the element of surprise. Therefore, one must assess the possibility of passive observation of network operations giving indications and warnings of impending actions. Such indications may be the identity of the end parties in an information exchange, a change in the volume of traffic or traffic patterns, or the timing of information exchanges in relationship to external events. The resulting potential security requirements are strong confidentiality and traffic flow security.

### 5.3.3.2 Active Attacks

This class of attacks may involve end systems or infrastructure. The most obvious network-based attack is the attempted login to a private computational resource. Bellovin shows how the ability to splice messages together can be used to change information in transit and cause desired results.[1] In the financial community, it could be disastrous if electronic transactions could be modified to change the amount of the transaction or redirect the transaction into another account. Reinsertion of previous messages could delay timely actions. Bellovin also brings up the issue of chosen plain text attacks<sup>1</sup> that can be used to bypass encryption mechanisms. [1]

Denial of service (DOS) attacks can be minimized by choice of network technologies. Any network that supports dial-up connections or routing of information can be used to deny service by flooding an end point with spurious calls or packets. More sophisticated attacks can involve manipulation of network elements.

---

<sup>1</sup> Many attacks are aided by making a machine encrypt plaintext chosen by the attacker. Many cryptanalytic attacks depend on the attacker being able to choose the plaintext to be encrypted. [1]

The following are resulting potential countermeasures.

- Strong access control.
- Continuous authentication.
- Integrity of information.
- Replay prevention.
- Network availability.

### 5.3.3.3 Insider Attacks

Many insider attacks are possible in a VPN. This is an architecture that concentrates on control of outside access. There is no additional mechanism to inhibit a person with legitimate access to a system from accessing more private areas of the VPN. A malicious insider could use covert channels to signal private information outside the VPN. However, there are many other avenues for a malicious insider to wreak havoc with an information system. Another threat that must be considered is the introduction of malicious code into a protected enclave. Such code can be easily imported through shrink-wrapped untrusted software, users swapping media with machines outside the enclave, or other paths that are implemented to import information from outside the VPN. Although many precautionary security requirements could be taken that are outside the scope of the virtual private networking scenario, the resulting potential security requirements for the VPN are establishment of security domains within the VPN and control of covert channels.

### 5.3.4 Potential Countermeasures

Privacy is maintained by appropriate use of confidentiality mechanisms. While application layer mechanisms can provide information confidentiality for classified and other critical applications, the problem with assured invocation of these mechanisms makes it difficult for these mechanisms to provide primary confidentiality mechanisms. The strength of confidentiality mechanisms for classified applications must be sufficient to withstand national laboratory strength attacks.

If traffic flow security is required, the best mechanism is one that prevents all insight into changes in traffic patterns. Therefore, the best mechanisms are link layer mechanisms on constant bit rate leased lines. Alternatively, lesser degrees of traffic flow security can be afforded by aggregating traffic through secure tunnels and by using traffic shaping mechanisms.

Many network attacks that involve manipulating cipher text or splicing information units can be countered by strong data integrity mechanisms and continuous authentication of the data channel. Replay can be prevented with cryptographic mechanisms that use timestamps or incrementing of counters to limit the acceptability of prior messages in the end systems. Continuously authenticated channels can prevent insertion of information into the channel. Such insertions could permit short plaintext attacks that would allow cryptanalysis by guessing known responses to known short messages.



Prevention of DOS attacks is often in the hands of the network provider. Use of provisioned networks will prevent many DOS attacks because the general population is unfamiliar with the management mechanisms in networks. However, there is little in present infrastructures to prevent manipulation of network hardware. The router authentication being implemented in the DISN is a start toward decreasing the vulnerability of networks to manipulation of network management information. Similar moves are being proposed within the Security Working Group of the ATM Forum for control of ATM switch configuration messages. Neither of these techniques is widespread so the network remains vulnerable to hacking.

Virtual private networking architectures provide little protection against the insider threat. Malicious insiders or malicious code introduced into the network all operate above network layers. These threats must be handled by higher layer services. If insider threats are a concern, the security implementation should also consider inclusion of firewalls, end-system-based privacy mechanisms, and protection mechanisms over the wide area network that limit exposure to covert channels.

## 5.3.5 Technology Assessment

There are many ways to implement a secure VPN. The easiest method for categorizing the options is to look at the possibilities as one moves up the protocol stack in a network. For purposes of this IATF, the discussion starts at link layer protocols where framing can take place. This is the lowest layer that can be transported through a standardized public infrastructure. The discussion stops at the transport layers. It should be noted that transport layer security services normally could only exist in end systems unless, at some future point, a transport layer proxy is created in a gateway device.

### 5.3.5.1 Layer 2 Protected Networks

The option of protecting a network at layer 2 is possible only if the owner has installed or leased a dedicated communications facility between sites. The security services that one achieves with a layer 2 protected network are strong site-to-site authentication, confidentiality, and a continuously authenticated channel. In most cases, one also achieves traffic flow security. An optional security service may be some data integrity functions or at least an antispoof capability.

A layer 2 protected network, given present protocol suites, cannot provide any true end-user authentication. It cannot provide any degree of privacy between users within the protected network at a reasonable expense. All switching and routing facilities will be Red facilities unless supplemented by other security mechanisms. This option contains no provisions for limiting information flow between facilities. If a firewall or equivalent function is required, it is inserted before the link encryption mechanisms.

Given the limitations outlined above, layer 2 protection for networks could easily be dismissed as not useful. However, some security mechanisms cannot easily be used in higher layers. The first mechanism is traffic flow security. If a user is concerned about receiving indications and warnings about impending actions, traffic flow security is imperative. Although, some traffic

flow security is possible using rate shaping of information, this technique requires nonstandard applications and protocol stacks, which could entail significant life-cycle costs.

The second mechanism not available in higher layer is the limitation in the number of covert channels. Covert channels are often viewed as either the gravest of threats to our information systems or a hobgoblin to be dismissed with a wave of the hand. The reality is that accreditors must have to evaluate the threat of covert channels to their particular information system and determine the desired level of protection against the threat. Although, a detailed discussion of any of these vulnerabilities is outside the scope of this paper, it does not take too active an imagination to postulate the existence of covert channels given that any field in a packet that can be modified or any parameter of transmission that can be varied is a potential covert channel. A layer 2 protected network removes all covert channel classes encompassing length of information transfer, timing of information transfers, and addressing of information transfers. Remaining covert channels can arise from the ability to exploit incompletely defined transport overhead and will be stemmed by the ability to control access to the overhead.

Another desirable property is that the simplicity of the design of link layer systems means that it is easier to achieve a target throughput at the link layer than at any other layer. As users reach for the limits of available communications technologies, it is more likely that a link layer solution will be the most acceptable solution. Table 5.3-2 summarizes the positive and negative characteristics of layer 2 protected networks.

**Table 5.3-2. Characteristics of Layer 2 Protected Networks**

Positive Characteristics	Negative Characteristics
Highest speeds possible	Highest communications costs
Highest protection against traffic analysis	No protection against cascading of networks
Highest protection against covert channels	No protection against insiders
Fewest avenues for network-based attacks	Can only authenticate from site to site
Continuous site-to-site authentication	Requires carrier to reconfigure network to add new nodes

- 1) **SONET.** SONET is the standard in the United States for trunking of data at rates greater than 45 Mbps. It is delivered in multiples of 51.84 Mbps with the minimum multiple being three. This service is referred as a synchronous transport signal 3 (STS-3.) If the entire capacity is treated as a single data container, the service is referred to as STS-3c, where the c denotes a concatenated service. The international version of this service is Synchronous Digital Hierarchy. The basic unit of service is a Synchronous Transport Multiplex, which is the equivalent of the SONET STS-3c transport. Present widespread deployment supports 155, 622, and 2488 Mbps transmission rates. Initial deployments of SONET at 9952 Mbps have occurred. Approximately 3.33 percent of the data flow is devoted to transport overhead. Another 1.11 percent is devoted to path overhead in nonconcatenated channels.

Presently, only government-developed equipment is available to secure SONET

## UNCLASSIFIED

System-High Interconnections and Virtual Private Networks (VPN)  
IATF Release 3.1—September 2002

networks. SONET key generators encrypt the data payload providing for strong confidentiality and complete traffic flow confidentiality. Data integrity must be handled at higher layers. SONET overhead passes through the system unaltered or, alternatively, only minimum fields are passed through the system undefined and network control channels are cleared. The operators of local SONET networks decide the level of transport overhead flow between local and wide area environments. A commercial device has been developed to meter these interactions between local and wide area SONET networks but the future of the device is not certain. No known commercial SONET encryptors exist at this time. However, a commercial entity has expressed interest in providing services based on such a device.

- 2) **Sub-SONET Rate Services.** The widespread data trunks in the United States are fractional DS-1, DS-1 at 1.544 Mbps, and DS-3 at ~ 45 Mbps. These services represent a multiplexed hierarchy for combining 64 Kbps voice channels into higher order trunks and eventually into SONETs adapted to direct transport of nonvoice data. The transport overhead varies from 1.4 percent for DS-1 service to 3.9 percent for DS-3. Trunk services are protected by a series of standard government-developed encryption equipment. These encryptors have been the basis of numerous VPNs based on provisioned services. In addition, numerous commercial offerings have seen a limited success in the marketplace. Commercial link encryptors are ripe for evaluation for possible use in layer 2-protected VPNs. Similar to the SONET devices described above, such link encryptors provide strong confidentiality, continuously authenticated channels, and traffic flow protection. They may also provide data integrity based on error extension properties of the encryption mechanism.

An interesting alternative to securing constant provisioned services is to apply an ATM-based solution. Because ATM can transport constant bit rate services, it is possible to use a cell-encryption-based technology to provide encryption services for link layer protocols. Many technical issues must be considered in the actual implementation of this technique. Among others, how the physical link is manifested at the service access point and relative costs are important considerations. Such a solution may not have all the security properties of traditional link encryptors. A discussion of the security properties of ATM will be included in a later release of this document.

- 3) **N-ISDN.** Narrowband Integrated Services Digital Network (N-ISDN) is a digital data transport system. It can be supplied in several forms including basic rate and primary rate services. Basic rate service consists of two data channels and one signaling channel with a combined capacity of 144 Kbps. In the United States, primary rate service consists of 23 data channels and 1 signaling channel for a total capacity of 1.544 Mbps. Europe and Japan use a different standard for primary rate service. Government equipment is being designed for N-ISDN. This device was initially prototyped as a single data channel and a single signaling channel and has since been followed with a version with two data channels and one signaling channel. No known commercial devices exist for native N-ISDN security. Security services available for N-ISDN depend on how security is invoked. Security can be implemented by encrypting complete data channels. Such an implementation would have security properties similar to the link

## UNCLASSIFIED

System-High Interconnections and Virtual Private Networks (VPN)  
IATF Release 3.1—September 2002

encryption devices discussed above. N-ISDN can also be used for multiplexed data transport. In fact, this transport is the basis of the commercially successful frame relay service offered by many carriers. If security is invoked at this layer, security properties will be the same as those discussed in the layer 3 section to follow.

N-ISDN is used as a low bandwidth connection between end systems and as a medium speed dial-up temporary connection between fixed and mobile systems. Direct dial-up secure N-ISDN represents a reasonable protection for dial-up access into a secure enclave, provided that policy allows such connections, strong user authentication is invoked, and procedures are put in place to protect classified information on a remote system while outside a protected enclave.

- 4) **Analog Phone Service for Data Transport.** Analog phone service requires a digital modem for transport of information across the analog link and is available as a dial-up medium for low bandwidth temporary connections. Newer modem technologies represent nearly the same capacity as an N-ISDN data channel without the set up charges and communications cost associated with N-ISDN. Commercial prototype encrypting modems have been developed for such secure data connection use and represent a reasonable method of providing a temporary link to a VPN, provided that strong user authentication is part of the connection process.

An alternative to the encrypting modem is the use of the data port of the government-developed secure telephones. Part of the authentication scheme for government secure voice equipment is the voice recognition between speakers. A totally automated system could bypass this important function. Many dial-up functions in low-cost computers accept manual dialing. A possible security policy would be to require audio identification of the sender before going secure or to require an augmenting strong authentication during log-in.

- 5) **Voice Transport.** Voice networks are often disregarded by the data network community, but in the DoD they still carry a large volume of secure traffic. Modern secure phones are based on digital representations of voice that are encrypted and sent across the network by digital modem. This is true whether the end system is connected to an analog service like Plain Old Telephone Service (POTS) and analog cellular service or a digital service like N-ISDN or newer digital cellular technologies. The distinction between voice networks and data networks is expected to diminish in the next few years. N-ISDN, ATM, digital cellular, and Internet phone are already blurring the lines. Government secure voice architectures have unified secure interoperability across most voice transport mechanisms. The exceptions to this rule are Internet Phone and native ATM voice transports. An area ripe for work is the extension of secure voice architectures into these newer network technologies.

### 5.3.5.2 Layer 3 Protection Across Public Networks

Layer 3 networks support dynamic routing and switching of information. For the purposes of the IATF, this discussion primarily covers IP and ATM transport. For this reason, the discussion is not complete. Network protocols like Network Basic Input/Output System (NETBIOS) and Internet Packet eXchange (IPX) are not covered. In addition, ATM spans a range of network layers. If implemented as a permanent virtual circuit, it becomes a strict layer 2 entity. In many implementations, ATM is used below layer 3 but above the Media Access Controller becoming the equivalent of about a layer 2.5 entity. Prototype applications are capable of completely replacing layer 3 solutions. Because of the cell switched nature of ATM, it is closer in properties to the pure layer 3 solutions and is therefore handled in this section. A protection philosophy based on layer-3-type networks offers the end users more affordable communications costs than layer-2-protected systems. A layer-2-protected system requires the provisioning of a new communications line and the acquisition of a pair of protection devices enables the new connectivity. With a layer-3-protected system, one only has to enable the access control mechanisms to allow the new connectivity. This comes at a cost of a higher risk of vulnerability to traffic analysis and the exposure to covert channel problems and directed network-based attacks. Table 5.3-3 summarizes the characteristics of layer-3-protected networks.

**Table 5.3-3. Characteristics of Layer-3-Protected Networks**

Positive Characteristics	Negative Characteristics
Some billing models charge by volume of traffic allowing greatest control of cost	Traffic analysis easy under some configurations
Most flexibility in adding new nodes to network	No protection against cascading of networks
Continuous site-to-site authentication possible	No protection against insiders
	Many covert channels for exploitation
	Many DOS attacks possible under some implementations

### IP Network

Only one widespread Type 1 system provides layer 3 protection for networks—the Network Encryption System (NES). This system uses a security protocol called SP-3 to encapsulate and transmit information securely across the Internet. NES has its own unique IP address and a broadcast address. When information is encapsulated, the outer IP envelope contains only gateway-to-gateway addresses. Therefore, end system identity is not available on the public Internet.

For this method to work, the device contains a configuration table that maps end system addresses to gateway addresses. The security services provided are site-to-site confidentiality, site-to-site authentication, and site-to-site integrity. Traffic flow protection of the aggregate data flow is not provided, although it is possible to write specialized applications whose purpose is to smooth the traffic flow across a site-to-site flow.

## UNCLASSIFIED

System-High Interconnections and Virtual Private Networks (VPN)  
IATF Release 3.1—September 2002

Numerous commercial IP encryptors also exist. These older commercial systems tend to have many proprietary features that preclude interoperability of equipment. Because of this lack of interoperability, it is not recommended that older commercial IP-based encryption systems be studied for securing DoD systems. For immediate applications requiring a layer 3-protection mechanism in support of the flow of classified information, NES is the only available solution.

There is potential for a widespread IP layer encryption solution based on what has been called IPSec. IPSec is the security framework that has been standardized by the Internet Engineering Task Force as the primary network-layer protection mechanism. IPSec consists of two parts, an Authentication Header (AH), whose purpose is to bind the data content of IP frames to the identity of the originator, and an Encapsulating Security Protocol (ESP) for privacy. The AH is intended to be used when integrity of information is required but privacy is not. ESP is intended to be used where data confidentiality is required. The draft Request for Comments (RFC) that defines IPSec architecture states that if data integrity and authentication are required with confidentiality, then an appropriate security transform should be used that provides all services. The minimum set of protection mechanisms consists of the DES for confidentiality and the hash algorithm MD-5 for authentication. The standard does provide room for negotiating alternative protection mechanisms through use of the Internet Key Exchange Protocol (IKE). IKE provides both a framework for creating security associations between endpoints on a network and a methodology to complete the key exchange. At least one published paper points out potential security concerns about using IPSec default security mechanisms. [1] The author points to occasions where the integrity functions of DES in Cipher Block Chaining mode can be circumvented with the right applications by splicing of packets. [1] The referenced paper recommends that AH and ESP be used together instead of individually.

ESP defines two methods of encapsulating information: tunnel mode and transport mode. Tunnel mode, when used at an enclave boundary, aggregates traffic flow from site to site and thereby hides end system identity. Transport mode leaves end system identity in the clear and is most advantageous when implemented at the end system. Figure 5.3-3 shows where the ESP header is placed within an IP datagram for IP version 6. In the more ubiquitous IP version 4, the section marked Other Headers does not exist. The AH precedes all nonchanging end-to-end headers. If one wanted to follow Bellovin's suggestion and use AH with ESP, the authentication header must immediately precede the ESP header. [1]

Although, no government-sponsored equipment currently implements IPSec, one such device is under development. TACLANE is an IPSec and ATM encryptor that is certified to handle classified information. It uses the ESP tunnel mode without the AH. It also does not implement the default IPSec algorithms of DES and keyed MD-5, because hard-wired security policy states that DES and MD-5 are not strong enough for Type 1 grade security. TACLANE always negotiates to higher-grade security mechanisms or does not commence data transmission. A follow-on development for the TACLANE program will provide fast Ethernet cards for TACLANE and increase its encrypted IP throughput to 100 Mbps.

It is recommended that all future IP security equipment be IPSec compliant. The primary confidentiality mechanisms should be implemented in security gateways that support no user-level processes.

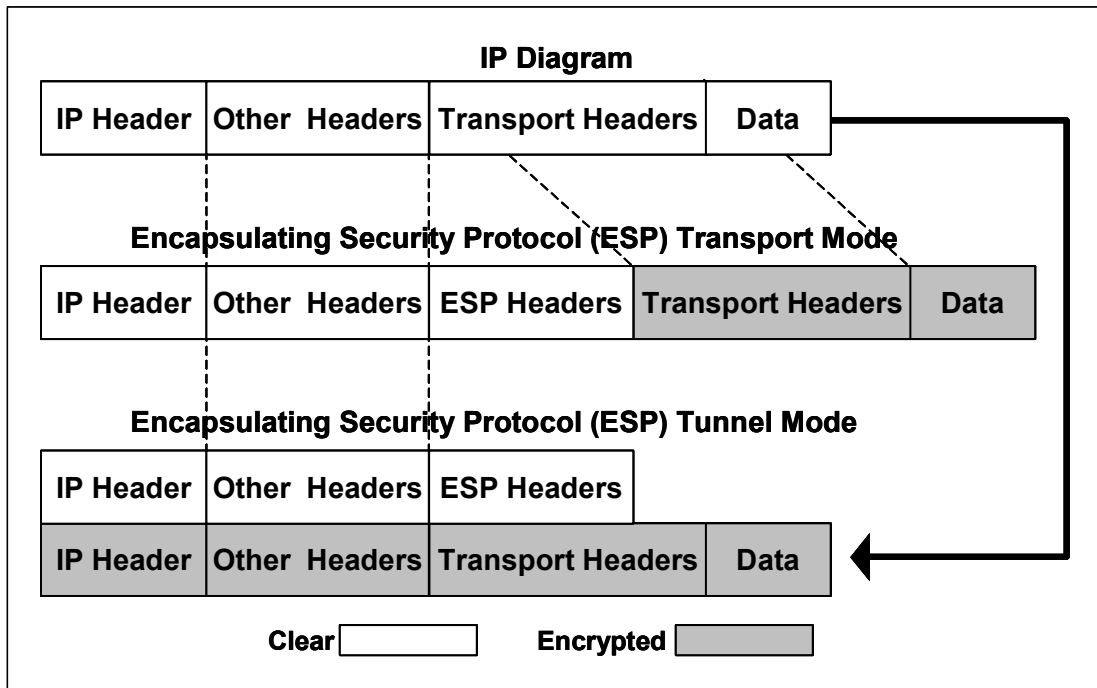

iatf\_5\_3\_3\_0014

**Figure 5.3-3. IP Layering Encryption Methods**

No Type 1 grade IPsec-compliant commercial encryptors exist. Even in current government developments, there are technology gaps for devices that can handle full Ethernet bandwidths, 100 Mbps Ethernet bandwidths, and Gigabit Ethernet bandwidths. In the commercial arena, there are many IPsec implementations for individual end systems and for firewalls. Both of these implementations will require Type 1 grade equipment.

## ATM

ATM security was developed in anticipation of requirements for high quality multimedia communications. The flexibility of the transmission mechanism makes it possible to tailor the security features of the system depending on how ATM is used. The standardization process for security in ATM is not as well established as that for the IP community, although some basic features and cryptographic modes have been defined through the Security Working Group of the ATM Forum.

Some of the main differences between ATM and IP include the following. ATM relies on a call set-up mechanism or explicit provisioning while IP routes are discovered en route. ATM relies on the state of a connection, while IP (especially version 4 IP) is stateless. ATM fixes cell size while IP uses variable size packets. IP frames carry end-to-end address information whereas ATM cells carry only local identifiers between each pair of switches. Quality of service in ATM is determined by availability along the entire route whereas IP quality of service is based solely on admission control to the network.

## UNCLASSIFIED

System-High Interconnections and Virtual Private Networks (VPN)  
IATF Release 3.1—September 2002

The primary motivations for considering an ATM security solution are the need to integrate high quality voice, video, and data applications and the need for quick implementation. Although the abilities of ATM are more apparent at the high end of communications, the mechanism scales across a wide range of operating rates.

Because IP packets can be reordered in transmission, each packet must contain sufficient information to enable synchronization of security mechanisms. ATM security can rely on the state of the connection to maintain synchronization. If the implementation is aware of ATM adaptation layers, information is available to deal with a limited amount of cell loss while maintaining synchronization. IPsec defines per packet authentication schemes through the AH. ATM security, as defined to date, does not have the equivalent function. Antispoof functionality is available that relies on higher layers to complete authentication, but the degree of protection is not the same as IP using the AH.

Because ATM can be implemented in so many ways and because the security services differ for each implementation, the options are discussed individually.

ATM can be used in a Constant Bit Rate (CBR) mode to connect enclaves emulating layer 2 trunk traffic. When ATM is used in this way while configured as a Permanent Virtual Circuit (PVC), all of the security services of secure provisioned link communications are available but provide more flexibility for upgrading service as required. If Switched Virtual Circuit (SVC) service is available at the enclaves, potential DOS attacks must be handled. Enclave-to-enclave IP over secure ATM (RFC 1483) has the same security attributes as IPsec in tunnel mode. Site-to-site identification is possible but the identity of end systems is hidden within the tunnel. Traffic rate is visible to the outside world but aggregation of large amounts of traffic and traffic smoothing can help obscure traffic flow information. Because of this similarity, this section refers to such a mode as a tunneling mode of ATM despite the lack of a formal definition. End-system-to-end-system secure ATM has security properties similar to IPsec transport mode. Complete end system identification is possible and individual traffic flows are discernible. Secure virtual paths allow end system identity to be hidden within a secure signaling channel within the virtual path. Though individual traffic flows will be discernible on the wide area network, there will be no information to tie the flow to an originator within the enclave except for perhaps stimulated events. Similar to the tunneling case, when end to end-user information is available, this section refers to that ATM transport mode as a tunneling mode.

The splicing attacks that Bellovin attributes to IPsec encapsulating security payloads may also be possible with ATM Forum-recommended encryption mechanisms.[1] This is an area for further study. If such an attack is possible, there is no equivalent to the AH to counter the threat. It is important to note that even if such attacks are possible with the ATM Forum-recommended modes, such attacks need not exist with all algorithm suites.

Government-sponsored equipment for securing ATM SVCs and PVCs are available for data rates up to 622 Mbps. A Type 1 interim system was developed for a single permanent virtual circuit that has limited availability. That Type 1 interim system also has a commercial equivalent. The previously mentioned government-sponsored IP encryptor will in fact produce a



## UNCLASSIFIED

System-High Interconnections and Virtual Private Networks (VPN)  
IATF Release 3.1—September 2002

combined IP and ATM encryptor. Further government developments are being considered for tactical platforms and for end-system use.

In the commercial arena, two companies have produced ATM encryptors. One unit operates over DS-3 circuits to secure a single PVC. Another unit operates at 155 Mbps and third unit operates at 622 Mbps. While none of these commercial units Type 1 grade, this is an area for commercial investment consideration.

The incorporation of native mode firewalls in ATM is in early stages of demonstration. No Type 1 products incorporate that functionality at this time. Some commercial systems have been demonstrated that incorporate simple IP packet filters. It is expected that there would be a similar need for encrypting firewall technology in ATM networks just as there is in IP networks. Although some doubt the extensibility of good firewalls to the level of performance that would be required in an encrypting firewall application, practical network administration makes the near-term utility of such a device very attractive.

### **Transport Layer Security**

Over the last few years, more attention has been given to providing a set of common security services in end systems. One version that gained acceptance actually existed just above the transport layer and was called Secure Session Layer Security. This effort has migrated to the Internet Engineering Task Force who placed the service at the top of the transport layer. This service is being called Transport Layer Security (TLS). One advantage of TLS is that this is the first place in the network stack where security services can be broken out per application rather than applying generic services to a secure pipe. However, this set of security services must be implemented in end systems and is therefore subject to all the invocation concerns of application layer services. The traffic flow problem is even more acute in TLS because of the visibility of individual services. At this point only early commercial implementations of TLS exist and none of these are the equivalent of Type-1-grade standards.

### **Super-Encryption in VPNs**

Super-encryption should be considered when there is a requirement to enforce privacy within the VPN. Such privacy may be implemented in end systems using lower assurance implementations of IPSec or ATM encryption under the control of an end system, TLS, or application-level mechanism implemented either in hardware or software. Alternatively, an entire subnetwork may be provided privacy by using a network encryption element. Note that this generalized description gives much flexibility to scale the level of protection mechanisms employed to fit the threat against an information system. Applicable architectures include link-protected switching and routing centers with end-system-based privacy mechanisms, link-protected switching and routing centers with enclave-based privacy mechanisms, and enclave-based protection backed by end-system-based privacy mechanisms. For instance, one should consider link-protected switching and routing centers with network layer security mechanisms if there is a traffic flow security requirement and the switching centers are maintained by unclassified personnel.

## Reverse Tunneling

In some scenarios, one needs to tunnel lower classification information through a higher classification system-high network. This is often accomplished by using the same high-grade cryptographic mechanism that would be required to tunnel high-grade traffic through a public network. Figure 5.3-4 illustrates the placement of cryptographic mechanisms for reverse tunneling.

The primary threat in this case is leakage of classified information into the lower classification tunnel. To help solve this problem, the cryptographic equipment should be under the control of the higher classification network and not under the control of the end users. If the lower level system is itself classified, it may have its own security

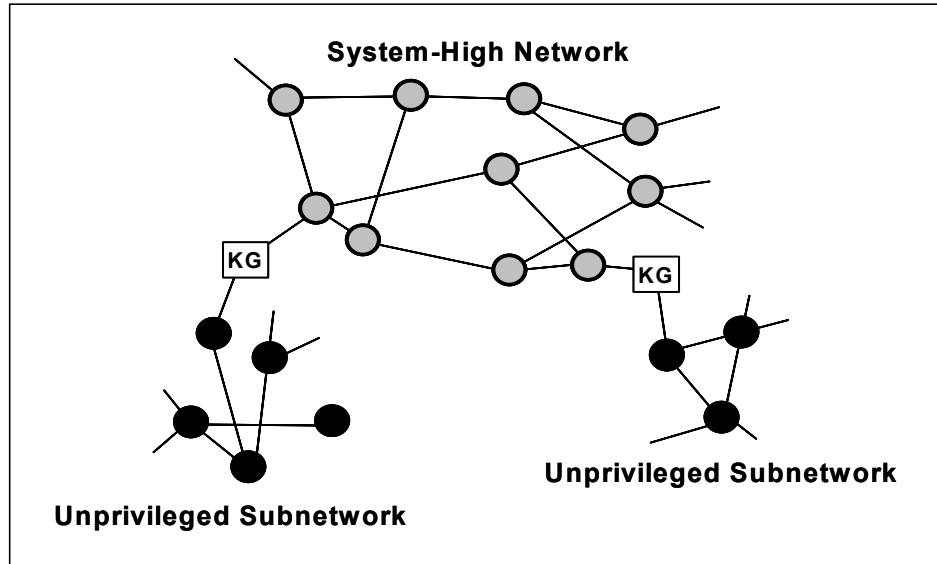

iatf\_5\_3\_0002

**Figure 5.3-4. Reverse Tunneling Placement of Cryptographic Mechanisms**

mechanisms. It is recommended that the network layer confidentiality system use a tunnel mode rather than a transport mode mechanism if one is available. Tunneling maximizes the isolation between the levels of information and prevents the low side from using short cipher to elicit recognizable responses from nodes on the high side of the tunnel. Although it is traditional to use cryptography strong enough for protection of classified information in the reverse tunnel, the information within the tunnel may only be unclassified. An area for investigation is whether well-implemented commercial systems can be used for such applications. Good implementation must address the need for strong integrity mechanisms on the secure tunnel. This will help prevent malicious code within the VPN from infiltrating information through the lower level tunnel. Finally, the implementation should consider what, in analog radio frequency devices, would be called reverse isolation. In particular, careful attention must be paid to unintentional leakage of higher level plaintext information through the encryptor and out the lower level information port.

## Relationship of Virtual Private Networking and Remote Access

The notion of virtual private networking implies an enclave of users who are protected from the network as a whole by some boundary device. Remote access implies a sole user gaining access

## UNCLASSIFIED

System-High Interconnections and Virtual Private Networks (VPN)  
IATF Release 3.1—September 2002

to the enclave by some protected means. Although the mechanisms to implement this access may be similar to that used for VPN, the details of the connection are vastly different.

Although dial-up access through a phone line resembles a VPN implemented at layer 2, it can implement security mechanisms at layer 2 or layer 3. The preferable solution would be a layer 2 protection mechanism with strong user authentication. An acceptable solution would be a layer 3 IPSec solution, given that the AH is implemented in the solution and strong user authentication is required. What makes these solutions more acceptable is that data exchange occurs directly between end systems without the need for protocol negotiation with an untrusted entity.

Remote access through an Internet Service Provider (ISP) using IPSec resembles an IP-based VPN. The primary difference is that remote access through an ISP consists of simultaneous connections to a private entity and a public entity without any intervening firewall or other protection mechanism. No monitoring of the information flow occurs between the remote host and the ISP to determine that no malicious transfers are taking place. This uncontrolled simultaneous connection between private and public entities takes this configuration outside the virtual private networking arena. Two areas of concern would have to be addressed before an ISP could be considered as a viable means of remote access to a secure enclave. The first concern is the window of unprotected access to the remote station during the period when the connection is made to the ISP but before IPSec or other mechanism can be invoked on communications with the secure enclave. The second is the concern that the remote terminal can become a convenient method for an insider to pass information outside the secure enclave because the remote terminal has simultaneous connection to the secure enclave and the unsecured ISP. The only solution would be a guaranteed invocation of the IPSec security mechanism across all IP source-destination pairs once a connection is made.

### **Role of Firewall Technologies in VPNs**

The resurgence of VPNs based on encryption mechanisms is largely the result of concern about penetrability of firewalls. However, encryption alone will only create secure data pipes between enclaves. There are no restrictions on the type and content of information that can be carried by that pipe. Joining enclaves with a secure data pipe also creates a default security policy that is the sum of the most promiscuous aspects of the individual policies. There are many situations in which this default policy applies. When connecting peer entities where the primary threat to the information is from external sources and where either all personnel accessing the system possess the same level of clearance or they may be deemed so trustworthy that they would not access restricted information given the opportunity, secure data pipes alone may be sufficient security. If these assumptions are not valid, the secure pipes must be supplemented by additional separation mechanisms. Firewalls are one way of providing that additional separation. Appropriate firewalls can allow an administrator to control the types of information flow across the VPN. For further discussion of firewall capabilities, see Section 6.1, Firewalls.

It is important to reiterate that, in this case, the use of a firewall is recommended for the situation in which two subnetworks are at the same security level but accreditors have assumed differing levels of risk in providing network security. Those interested in the case in which high-to-low connections are required should refer to Section 6.3.1, Guards, of this document.

## UNCLASSIFIED

System-High Interconnections and Virtual Private Networks (VPN)  
IATF Release 3.1—September 2002

There is a great diversity in the quality of implementation of firewall technology, and the purpose of this section is not to rate implementation quality. However, some general guidance on when to use firewalls and how restrictive they should be is appropriate.

- Primary protection between classified systems should be through some lower layer encryption system. Although these devices provide no protection against malicious users inside the network, they do limit accessibility of the VPN by outsiders.
- When true peers are connected, no firewall should be required.
- When applications demand high bandwidth, firewalls are likely to fail to meet the requirements. One area for suggested research is techniques to increase the throughput of a firewall while maintaining its effectiveness.
- When two connected systems are not exact peers, use of at least one firewall is recommended, and it should be placed at the enclave with the most demanding security requirements.
- When a firewall is required, the restrictions on connectivity should be commensurate with the minimum communications requirements and the difference between security levels and compartmentation within the respective enclaves.

### Interoperability of VPN Protection Technologies

Up to this point this section on VPNs is written as though the population were segmented into defined communities that have no communication with each other. Under these conditions, it is easy to define a unique security solution for each community. Within the DoD, such islands of communication cannot exist. During times of contingency, lines of communication are likely to be opened where none had been planned. This creates a conflict between the need for interoperability between organizations and the need to design a secure communications infrastructure that meets mission needs. The following are possible solutions to the interoperability problem.

- Require a uniform communications and security infrastructure.
- Require end systems to implement all security features and require peer-to-peer negotiations.
- Implement gateways that convert information to plaintext and reencrypt in the appropriate format.
- Develop methods of maintaining confidentiality through interworking functions.
- Implement redundant security mechanisms and modify protocol stacks to give visibility to the invocation of security mechanisms at all layers.

Of these options, 1 and 2 are unworkable for the following reasons.

## UNCLASSIFIED

System-High Interconnections and Virtual Private Networks (VPN)  
IATF Release 3.1—September 2002

- A uniform solution will not meet all requirements, and requiring that all systems carry all security mechanisms is too expensive.
- These options will likely result in failure to communicate if any of the peers fail to complete a secure setup, or in compromise if the default is to pass the requirement for securing the communications to the next higher layer when peers fail to negotiate secure setup.

Options 4 and 5 are research areas at this time. The TACLANE equipment, in some sense, is an early implementation of option 5. If a secure ATM call setup fails, the device assumes that communications must be secured via IPSec. This, however, is a point solution and does not address the breadth of interoperability problems.

Therefore, in the near term, the only viable solution is option 3, red gateways between dissimilarly protected networks. Research is needed to determine whether options 4 or 5 can be viable at some point in the future to reduce plaintext exposure created by the use of the option 3 red gateways.

### 5.3.6 Cases

To apply these security technologies to user networks, it is most convenient to describe typical situations that must be encountered. In each of these situations, it is assumed that the end networks are of a single level of classification, employ the same structure of components, and that consistent security policies are in place. The following cases are considered.

- Classified networks connected over public infrastructures where indications and warnings are not a consideration.
- Classified networks connected over public infrastructures where indications and warnings to adversaries must be considered.
- Unclassified but controlled networks connected over public infrastructures.
- Tunneling of lower classification information over a classified system-high network.
- Tunneling of higher classification information over a classified network.
- Maintaining compartmentation and privacy over a secured classified network.
- Single backbone architectures for voice, video, and data.
- Connection of networks where subnetworks have incompatible security policies.

## 5.3.7 Framework Guidance

### **Case 1: Classified Networks Connected over Public Infrastructures Where Indications and Warnings Are NOT a Consideration**

This case covers the connection of classified enclaves when traffic flow security is not a priority, and it represents the majority of deployed classified VPNs. This case applies when the communications on the network are not involved in the planning and deployment of strategic or tactical forces, when the network is not involved in sensitive time-dependent operations, and/or when there is no tie to strategic intelligence sensors where reactions of the network can be used to probe the capabilities of sensors.

Three viable alternatives exist for creating secure VPNs over public infrastructures for this case. The most secure is to use Type 1 link-layer protection. This gives the greatest protection against outsider attacks on the network and the fewest means for malicious insiders to send information outside the network. This level of protection comes at the cost of increased communications cost and inflexibility in expanding or changing the network layout. Almost as good a choice would be using circuit emulation on an ATM permanent virtual circuit using Type 1 ATM encryption. This solution may give some cost flexibility.

If communication costs or the need for flexible communications precludes the use of leased circuits or circuit emulation, network-layer-based solutions should be considered. Type 1 enclave-based solutions are recommended. NES is an example of a Type 1 enclave-based solution for IP-based network topologies. Other, more standardized Type 1 IPSec-compliant solutions also are available. FASTLANE and TACLANE provide Type 1 solutions for ATM-based topologies.

There are no host-based Type 1 systems for network layer protection at this time. While this class of solutions can potentially be very cost-effective, the strength of invocation has not been sufficiently addressed to make a recommendation that such solutions be used. There are no commercial security systems of sufficient strength for protection of classified information at this time.

### **Case 2: Classified Networks Connected Over Public Infrastructures Where Indications and Warnings to Adversaries MUST Be Considered**

What distinguishes this case from the previous one is that observation of external traffic patterns even without decryption of the underlying information could give critical information to adversaries. For example, if a network extends into a tactical theater of operations, changes in traffic patterns may indicate the imminence of offensive operations thereby prohibiting the element of surprise. Another example would be where a network can be identified as processing information from critical sensor platforms. Here probing the sensor and observing resulting traffic patterns can give away sensor response times and sensor sensitivity.

## UNCLASSIFIED

System-High Interconnections and Virtual Private Networks (VPN)  
IATF Release 3.1—September 2002

The basic solution set is the same as the previous case. The best solution is still the Type 1 link-based security system. The reasons provided in Case 1 still hold, with the addition of the complete traffic flow protection. Although, the existence of links can be easily identified, the change in traffic patterns is indiscernible.

If link-based solutions are not feasible, prime consideration should go to enclave-based network layer solutions that tunnel multiple logical connections through a single path. This solution is represented by the NES because it tunnels enclave information via IP packets that are addressed from NES to NES. As Type 1 IPSec-compliant systems that use the IPSec tunnel mode become available, these systems also will meet security requirements. ATM wide area connections can provide some of the same capabilities for IP LANs because multiple IP source destination pairs can tunnel through the same ATM virtual circuit.

As end-to-end ATM applications become viable, tunneling will become more difficult because individual virtual circuits will be set up between end systems for each source-destination pair. The best solution for this case will be a secure virtual path service between enclaves, which will at least enable identification of the end points of each virtual circuit to be encrypted within the virtual path. However, the characteristics of each data flow will be observable. When traffic analysis is a threat, any of the network-based solutions, especially the end-to-end ATM solution, can be made better with rate shaping of the traffic by the end systems.

No host-based Type 1 systems for network layer protection exist at this time. Although, this class of solutions can potentially be very cost-effective, the strength of invocation has not been sufficiently addressed to allow a recommendation that such solutions be used. No commercial security systems of sufficient strength for protection of classified information exist at this time.

### **Case 3: Unclassified But Controlled Networks Connected Over Public Infrastructures**

This case is the unclassified but controlled version of Case 1. The difference in the solution is that commercial-strength mechanisms may be adequate for protection without going to the expense of a Type 1 equipment. The security benefit is probably insufficient to consider a link-layer protected solution for the unclassified but controlled case. It is recommended that a commercial enclave-based network layer solution be used whether that solution is ATM or IP-based. A mode that supports IPSec tunneling or the ATM equivalent is preferable to a transport mode solution.

Host-based solutions are not recommended for primary protection of a direct connection to public networks until further testing has been accomplished to check strength of invocation and their ability to be bypassed.

## **Case 4: Tunneling of Lower Classification Information Over a Classified System-High Network**

This case exists when a classified network that already exists is protected at a link layer and used to transport unclassified or unclassified but controlled information as a matter of convenience. In this situation, protection has traditionally been implemented with Type-1-encryption systems as in the case of the tunneling of unclassified information through Secret Internet Protocol Router Network (SIPRNET) using the NES.

The properties desired from such a solution are that the mechanism be sufficient to protect information that is presented to the network, that invocation cannot be bypassed, and that reverse isolation of the mechanism be sufficient to prevent leakage of the higher classification information onto the lower classified network. Strong data integrity mechanisms must be part of the security services offered by the security device used. These mechanisms are used to protect the information on the low side of the connection but to eliminate the possibility of malicious insiders using the channel as a means to send information out of the secure network.

Although Type 1 solutions can still be used for such applications, commercial network layer systems should be considered. In addition, a tunneling mechanism should be mandatory. Note that this requirement eliminates IPSec transport mode solutions. The equipment implementing the security should be under the ownership, control, and configuration of the higher classification network. The system must not be able to be configured from the port that is connected to the lower classification network.

## **Case 5: Tunneling of Higher Classification Information Over a Classified Network**

An example of this type of application would be the tunneling of a Top Secret network like the Joint Worldwide Intelligence Communications System (JWICS) through the SIPRNET.

The central issue in this case is whether the solution must be as strong as that required for tunneling over an unclassified network or, because protection is provided in Case 4 to deal with the use of a lower classification network, whether a weaker mechanism can be considered.

It is recommended is that a Type 1 enclave-based tunneling mechanism be required. The mechanism should be under the control of the higher classification network.

## **Case 6: Maintaining Compartmentation and Privacy Over a Secured Classified Network**

The difference between this case and Case 5 is that compartmentation is an enforcement of need-to-know among people who are equally cleared. It is assumed that the protection on the network is already sufficient to deter penetration by outsiders. Therefore the real need is for privacy within the network rather than protection from malicious outsiders. Although application layer



## UNCLASSIFIED

System-High Interconnections and Virtual Private Networks (VPN)  
IATF Release 3.1—September 2002

solutions are sufficient for lower bandwidth applications, more demanding applications will probably require some network-based privacy solution.

Given the threat environment, this is an ideal case for using commercial host-based solutions, whether IP transport mode or ATM end-to-end.

### **Case 7: Single Backbone Architectures for Voice, Video, and Data**

This architecture was one of the primary motivations for the development of secure ATM (in addition to the scalability and the speed of implementation). By placing the security at the ATM layer, a single set of mechanisms successfully protects all information that crosses an enclave boundary. That vision is too optimistic. Problems occur with voice connectivity. A secure voice architecture currently covers all transport means except broadband voice. Although ATM security is perfectly capable of protecting voice communications, the problem is the lack of secure interworking between broadband voice and secure N-ISDN and POTS voice. Until these interworking issues are resolved, it is not recommended that broadband voice services be secured with native mode ATM security services.

### **Case 8: Connection of Networks Where Subnetworks Have Incompatible Security Policies**

The previously recommended solutions for VPNs all assume that the enclaves have compatible security policies. Under present security guidelines and as a risk management philosophy becomes more widespread, security policies are likely to diverge. Therefore it is expected that enclaves to be connected will have security policies that are incompatible in some way. In the standard virtual private networking scenario, the unimpeded flow of information within the virtual network create a resultant security policy that is a fusion of the most liberal aspects of the security policies of the individual enclaves. The system security administrators of the individual enclaves either need to recognize the resultant security policy and assess the impact on their systems or an additional separation mechanism must be added to help enforce the desired policy. This case is an ideal place for the marriage of firewalls with VPNs. In this respect, the commercial community is far ahead of the Type 1 community with the widespread availability of encrypting IPSec-compliant firewalls. When additional separation is required, an appropriate IP or ATM-based firewall that implements features needed by the enclave, cascaded with the Type 1 enclave protection mechanism, is recommended.

## UNCLASSIFIED

System-High Interconnections and Virtual Private Networks (VPN)  
IATF Release 3.1—September 2002

### References

1. Bellovin, Steven M., “Problem Areas for the IP Security Protocols,” July 22–25, 1996, San Jose, CA: *Proceedings of the Sixth Usenix UNIX Security Symposium*, 1996.  
<http://www.usenix.org/publications/library/proceedings/sec96/bellovin.html>

This site provides an abstract of the document. You must become a member of USENIX to see the full text of the document. To become a USENIX member, see the Membership Information link on the Web site.

### Additional References

Virtual Private Networks, Faulkner Information Service, Pennsauken, NJ, May 1996.

**UNCLASSIFIED**

System-High Interconnections and Virtual Private Networks (VPN)  
IATF Release 3.1—September 2002

**This page intentionally left blank.**

## 5.4 Security for Voice Over Internet Protocol (VoIP)

Although Voice Over Internet Protocol (VoIP) has been around for many years, it has only recently gained widespread interest and implementation. Because it is a fairly new technology, it has not undergone the same level of scrutiny and use as more established technologies.

Although many of the risks associated with VoIP are known, there is still much to be learned. In some ways, we are still at the point in the learning curve where we don't know how much we do not know. Some of the risks and vulnerabilities related to VoIP will be remedied as the technology evolves, but there inevitably will be some residual risk that cannot be ameliorated. It is still difficult to determine what portion of the current security issues fall into the "fixable" category, and which must be classified as "managed residual risk."

Because VoIP is still, to a large extent, an unknown quantity, this section will discuss the related security issues at a conceptual level. Thus, we will not indicate a particular setting of a particular field in a given protocol as a problem but will discuss the issues in generic terms. For example, we may discuss crypto as a source of delay, which may affect voice quality, but we will not suggest a particular crypto algorithm or piece of crypto equipment. In addition, because the technology is still in the "early adopter" phase, this section takes a somewhat cautionary tone: Prudence dictates that security practitioners take care when faced with technologies that have not yet established a strong foundation of security analysis and experience.

Although this section focuses on Voice Over Internet Protocol, many of the same general concepts may be equally valid for similar technologies that move digitized voice over digital networks using protocols that may have been originally designed for data networking rather than voice. Such technologies include, but are not limited to, Voice over Frame Relay (VoFR), Voice over Asynchronous Transfer Mode, and Voice over Digital Subscriber Link. These related technologies are discussed briefly in Section 5.4.5, but a full discussion of the technologies and their place in a total Internet telephony solution will have to wait for a future update of this section.

The key feature of all of these related technologies is the migration of voice from its historic technological underpinnings of analog signals on a synchronous, connection-based architecture to a digital signal moving over a packet-switched architecture. The latter means of transit is asynchronous, although it is perceived by the end user as being "real time." This migration has created several complications and necessitated the revisiting of some of the underlying design assumptions of traditional phone networks.

A critical feature of this technology shift is the culture shock that occurs when technical personnel who have worked with telephone networks and those with a network background must work together. The tendency is for each group to view the problem of a converged network encompassing data and voice in the context of its own experience and history. Telephony engineers tend to think of the system as a phone network that is using new technology and expanding to include data, while data network engineers view voice on their digital networks as

## UNCLASSIFIED

Security for Voice Over Internet Protocol  
IATF Release 3.1—September 2002

just another type of bits. In reality, both groups must undergo a significant learning process as they become familiar with problems and concerns that those from the other camp view as common knowledge. Each group must familiarize itself with the basic concepts and knowledge of the other group and fill in the gaps in its own knowledge. Only when this initial acclimatization has occurred can the two groups effectively consider the complications that arise from the interactions of these formerly separate realms.

To assume that installing VoIP is “...just like hooking up <familiar product or piece of equipment>” seriously understates the system-level implications. Like any new technology, there are nuances that may not be initially recognized, especially when the transition involves new architectural assumptions not just a direct replacement of an old technology with a newer one.

An additional area in which the transition from one set of assumptions to another will prove critical is the realm of law, regulation, and policy. With VoIP, any new technology, it will take some time for the rules to catch up with the technology.

A tangential issue that may have an indirect impact on security is the perception that significant cost savings will be generated by switching to VoIP. The argument is that moving from two separate infrastructures to a single infrastructure, will naturally produce a great reduction in cost. Although there has now been some cost analysis of the short-term expenses incurred for equipment, wiring, personnel (retraining, hiring, or replacement), and the transition of telephony bandwidth to network bandwidth, these cost figures are for nonsecure environments. It remains to be seen whether security considerations will increase costs, or even mitigate against converging into a single network. There may be both security and reliability arguments for moving voice to a separate packet-switched network.

Poor cost planning can have hidden implications for security. If cost estimates for switching to VoIP are not carefully performed, resources originally allocated for security might instead be tapped to achieve basic functionality. Estimates of the costs of security for the new technology may also be inaccurate, due to VoIP's brief history and the new assumptions and interrelationships it brings with it. Conservative budgeting is called for to avoid shortfalls caused by imprecise understanding of the costs of implementing the core technology and applying security functionality on top of it.

In some senses, attackers are in the same situation as defenders with respect to VoIP. They too are facing a new technology and will probably need time to develop the theories, tools, and techniques to maximally exploit it. Although some VoIP attack tools are available and other tools and exploits from the data network realm can be adapted for use against VoIP, the threat is still in a ramp-up mode. It is hard to predict how long this stage will last. At least one factor will be the market penetration of VoIP in the coming months and years. As potential targets increase in number and attractiveness, the likelihood that the technology will draw adversary attention increases. This may result in a race between attackers and defenders as to who will turn their attention to any particular vulnerability first. This second stage will introduce a now familiar cycle, with advantage swinging back and forth between attackers and defenders as new

vulnerabilities are found and techniques to minimize or exploit the vulnerabilities are deployed by the respective sides.

## 5.4.1 Target Environment

VoIP is potentially a functional replacement for both regular and secure phones and can, at least hypothetically, be used in any location where more traditional phones have been used in the past. That said, the transition to VoIP is not simply a matter of unplugging the old handset and plugging in the new one. In VoIP, the majority of the changes are hidden from the end user, involving replacement of telephone cabling, private branch exchanges (PBX), and other equipment with network cable, routers, and other such elements.

The target environment is in some ways very familiar, since there is broad user experience with data networks and basic phone usage. At the same time, use of a phone over a data network and its implications from an administrative perspective are very new. The technology and issues are understandable, though complex. What is unclear is how best to adapt the historically connection-based synchronous phone system model to a packet switching–based asynchronous infrastructure, and the implications of that transition.

Another set of issues concerning the new environment is the policy, legal, and regulatory framework that covers the phone system and the data network. Numerous laws, policies, and regulations, on issues ranging from wiretaps to Emergency 911 functionality, have been developed over the years with the traditional telephone system in mind and with the assumption that the telephone network is a fairly homogeneous and isolated environment. Similarly, some existing laws, regulations, and policies governing the operation of data networks may not cover the concept of content other than traditional data. Although there have already been attempts to adapt regulation and law to the new technological landscape, it may be many years before the legal and regulatory picture stabilizes.

There are numerous questions about how the combined environment will be treated. For example, there are now specific rules on the treatment of information that flows over government networks, such as e-mail and file transfers. Some of this information is designated as “official government records” based on its presence on a government network, how it was generated, how it is stored, and so on. Once telephone conversations are converted to data packets on a government network, do those same rules apply? On the other hand, does a network sniffer become an illegal wiretap if it sniffs VoIP packets (as it would if the same content were intercepted on the public switched telephone network [PSTN])? For legal purposes, what makes a phone call a phone call as opposed to data?

Because this technology is so new, we will not attempt to define specific target environments in detail. (There are just too many possible architectures and implementations for us to pick the ones that will become commonplace.) Instead, we will present the issues that may apply in various contexts, with the assumption that the reader will select, and perhaps extrapolate, to derive useful information regarding a specific usage scenario. Nevertheless, it is clear that there

will be nuances in the development and implementation of this technology that are either underappreciated, or have not yet been recognized.

## 5.4.2 Requirements

The general intuitive requirements for VoIP can be stated simply: VoIP is to provide a functional replacement for a traditional telephone infrastructure in a given context. However, in meeting user expectations, more detailed requirements emerge, some of which may be optional in some circumstances. These more specific requirements include, but are not limited to, the following items:

- Acceptable voice quality in real time (<150 ms delay).
- An acceptable addressing scheme, which may or may not map directly to existing phone number schemes, but which must be translatable to existing phone networks and legacy systems.
- Access control to allow one to limit calls into or out of the organization's telephone infrastructure from either a public system or another enclave on the basis of such factors as calling number, called number, time of day, and others. This type of access control is what one would expect from a conventional private branch exchange (PBX), and this functionality should not be lost in a VoIP implementation. Indeed, this capability may prove to be more crucial in the VoIP realm than it was in traditional telephony.
- Sufficient auditing and billing functionality to meet mission, regulatory, and statutory requirements.
- Cost which is equivalent to, or an improvement over, existing phone technology, when all factors are added in.
- Ability to interface and interoperate with existing secure telephone technology, such as secure telephone unit (STU) III and secure telephone equipment (STE).
- Quality of service, including reliability and availability, that is comparable to that of existing telephone technology.
- Call prioritization and preemption capabilities, including both prioritization of telephone calls (e.g., "the General's call always goes through") and prioritization of telephone traffic versus data traffic on the network to maintain acceptable service levels.
- Emergency 911 geolocation information, as required by law and/or regulation (and perhaps the ability to disable it for some applications).
- Robustness. A converged network is a single point of failure; therefore, it must be designed for redundancy, fault tolerance, and graceful degradation.
- Confidentiality. Sniffing a network is easier than tapping a traditional phone network, in large part because it requires less precise physical access. Therefore, some sort of

confidentiality mechanism may be needed to achieve functionality (even basic functionality) equivalent to that of the traditional phone network.

- **Legality.** All pertinent legal and regulatory requirements applicable to the traditional phone network must be met in a VoIP environment. However, as noted in the previous section, it should not be assumed that the same rules automatically apply in the same ways in the new environment. Therefore, there should be a conscious effort to determine the ground rules when using the new technology.
- Connection to the PSTN must not introduce errors or vulnerabilities to the PSTN, lest the PSTN decline to allow the connection.
- Feature set (conferencing, call waiting, call forwarding, voice mail, Caller ID, automatic dial-back, etc.) similar to the standard feature suite one expects from PSTN service.
- Traffic management and load monitoring capabilities similar to what one would expect from a typical PBX installation.

### 5.4.3 Potential Attacks

Research regarding potential attacks on VoIP systems is still in its early stages. The technology has not been around long enough for truly creative or detailed exploits to be developed or hypothesized. Nevertheless, many aspects of these systems are likely to provide fertile ground for those interested in exploiting VoIP. Some of these attacks will involve simple exploitation of “beginner’s mistakes” that will be rapidly corrected as the technology matures. Other forms of attacks will focus on flaws that are much more deeply rooted, and will be more difficult to prevent or mitigate.

The following list of attack types should not be viewed as complete. This technology is still too new for practitioners to fully understand the threat situation and its nuances.

- **Direct Access Over the Network.** If the phone is on the network, it is likely that some of its functions (speaker phone, room monitor, etc.) will be remotely accessible over the network. Limiting such access to authorized usage may be tricky.
- **Network Sniffing.** The original telephone infrastructure was designed to create a point-to-point link between caller and recipient, with the assumption that there would be no other parties on the line. Switched-packet networks are designed to send data over commonly accessible paths. Any signal that is not protected by encryption or other means must be assumed to be accessible to an adversary, possibly without the direct physical access that was generally necessary to tap the PSTN.
- **Manipulation of Traffic Flow.** Data networks are inherently asynchronous, in that the data packets do not flow over a dedicated connection for the duration of a session. By manipulating the routing of packets, an adversary could cause dropouts, insert latency (time delay between transmission and reception), or insert jitter (variation in the latency). Although such attacks make little sense in a data network, except in very specialized



## UNCLASSIFIED

cases, they would have significant effect on the perceived quality of a connection to a voice user. It remains to be seen how difficult such attacks would be to implement, or how prevalent they will become.

- **Data Exfiltration.** VoIP traffic will require what is essentially a high-bandwidth breach of guards and firewalls, so as not to incur too much delay. It is also a given that VoIP packets, unlike data packets in known formats, will be very difficult (perhaps impossible) to scan for legitimate content or hidden data without introducing unacceptable delay. Unless effective means are found to isolate VoIP traffic from data traffic, VoIP will prove to be an attractive vehicle for data exfiltration, either by malicious Trojan horse code, or by an insider with bad intentions.
- **Denial of Service (DoS).** While a DoS attack could take many forms, the most obvious would be taking down or flooding the network, or some portion thereof. In the traditional system, if the network were rendered inoperable, an organization could still maintain some communications functionality over the phone. In a commingled “converged network,” one would have both (i.e., network and phone service), or neither. This situation creates an attractive target. Obviously, if the VoIP portion of the network were isolated from the data portion, or if there were a fall back to traditional telephone infrastructure, this type of attack could be less effective.
- **Routing Delay Attacks.** An adversary might attempt to artificially induce delay to ensure that particular phone conversations were routed through particular network paths. In this way, an adversary could potentially choose a location for a packet sniffer or other monitoring equipment, then maneuver the desired traffic past that point.
- **Control/Signaling Attacks.** As noted, modern data networks often run control and data signals over common links. Hypothetically, this is also possible on conventional phone networks, but given the limited access to the switching systems, the phone network is less vulnerable.
- **Bandwidth Attacks.** If an attacker could tie up sufficient bandwidth on a given link, there might not be sufficient throughput to support VoIP voice encoding schemes, which assume a certain minimum bandwidth to function properly.
- **Protocol-Based Attacks.** Because VoIP is still new, it remains to be seen what might occur if an adversary manipulated the various protocols in unanticipated ways. More analysis of the protocols and the implementations in various equipment is needed to determine what protocol-based vulnerabilities to buffer overflows, man-in-the-middle attacks, traffic analysis, content-based attacks, or other mischief may exist in VoIP systems.
- **IP Spoofing.** IP spoofing is a well-known class of data networking attacks, in which an adversary hijacks a session, assuming the identity of the intended recipient. It is not hard to imagine the use of these same techniques to reroute or intercept VoIP phone traffic, allowing either masquerade or man-in-the-middle attacks.

- **Domain Name Server (DNS).** DNS system is a sort of distributed repository of network address information. It is roughly analogous to a phone book, allowing one to query based on an identifier such as a name, and get a corresponding address, usually expressed as a series of numbers in a particular format. At present, there is little security or authentication in the DNS system. As phone traffic moves to Internet Protocol (IP), the DNS system will become an even more critical piece of the infrastructure.
- **Brute Force Password/Personal Identification Number (PIN) Attacks.** Because a telephone handset (the entry mechanism in the VoIP environment) has only a numeric keypad, the possible symbol search space for passwords and PIN is greatly reduced. The limitations of human memory limit the useful length of a PIN or password even further. The result is that passwords and PINs are likely to be less secure. Alternative forms of identification and authentication (I&A) may be needed in some applications.

## 5.4.4 Potential Countermeasures

This section, like that on potential attacks can provide only general information, because the technology is still too new to have an established repertoire of proven tools and techniques.

However, it is anticipated that the most critical areas for countermeasure development will be in the realm of encryption, covert channel/steganography detection and prevention, and protection against protocol-based attacks.

- **Encryption.** Various efforts to use high-speed links or end-to-end encryption have been made in early VoIP installations. The critical concerns are latency, jitter, bit error rate, error propagation, and bandwidth. As is often the case with encryption, the implementation details are crucial to success. One should also be aware of the various levels at which encryption can be applied. Application layer encryption can provide end-to-end coverage but increase covert channel problems at firewalls and guards because of the traffics being encrypted. Virtual Private Networks (VPNs) and link encryptors may be used at the network layer but may require decryption and re-encryption at various points, leaving the message exposed briefly at some nodes. Encryption can also introduce delay, either during call setup or as latency during the session. If the encryption is not sufficiently fast, some form of voice compression may be required for effective use.
- **Firewalls/Guards.** The use of VoIP requires the adaptation of the firewalls in the network to allow access to ports used by VoIP and to allow out the various protocols VoIP use. Because an adversary could use these paths as well, configurations must be chosen carefully. Note that in this instance the concern is not so much about the impact on VoIP, as about the effect of the introduction of VoIP equipment and traffic on the security of the preexisting data network. In a similar vein, it is unclear how VoIP can be incorporated across a network boundary protected by a guard. The very concept of a guard, or other secure downgrading mechanism, implies a degree of delay that would be unacceptable for VoIP. In such cases, another solution for the voice traffic must be found, whether this entails putting VoIP only on networks (whether unclassified or

“system high”) that do not require the downgrade function or reverting to traditional telephony solutions.

- **Covert Channel and Steganography Detection.** Whereas the preceding item addressed the need for adaptation of existing firewalls and guards and the effects on the preexisting data network, this item assumes that additional filtering or monitoring will be necessary to detect modulation or other misuse of legitimate VoIP traffic flows to carry covert data either in or out. Historically, identification and prevention of covert channels have constituted one of the knottiest problems in computer security, even when confined to the data realm. The additional need to detect covert channels in the underlying analog signal increases this protection challenge significantly. This problem may require isolation of the VoIP system to prevent introduction of modulating signals. This is another area in which combining digital signal processing and the sharing of a single network between voice and data create a class of risk that was not present (or was far less likely) in separate voice or data systems.
- **Traffic Flow Tools.** Given the relative accessibility of network traffic information, protection against traffic analysis may be more crucial in a VoIP realm than in the more closed environment of a traditional telephone network. As a result, there may be a need to create a means of disguising traffic flow patterns, either by covering or masking routing information or by generating bogus traffic to disguise the flow of the real calls.
- **TEMPEST.** Given the high bandwidth of a VoIP channel, we may need to be conscious of potential modulation of the signal by other equipment in the operational environment. TEMPEST analysis of relevant equipment may be necessary in some environments.
- **Anti-Tamper.** The VoIP channel’s high bandwidth and the ability to remotely access the VoIP equipment over the network make the VoIP handset an attractive target for such basic tampering as modifying the switch that disconnects the handset microphone when the phone is on the hook. There are many other tampering possibilities, but most can be addressed by a standardized program of inspection and analysis of the equipment, combined with simple tamper-detection mechanisms.

## 5.4.5 Technology Assessment

### 5.4.5.1 Technology Assessment and Selection Overview

Because VoIP is an emerging technology, there are as yet no well-established, objective selection criteria, and the various possible architectures and configurations have not yet narrowed down to a few canonical variants. Adding to this problem is the fact that the traditional telephone system is such an established technology that its functionality has come to be assumed. We take for granted functionality such as call prioritization or preemption, echo canceling on

long-distance calls, “toll quality” voice reproduction, universal access, and relative privacy of individual calls, among other functions.

In the absence of accepted selection criteria or an established body of worked examples of successful and secure implementations, adopters of VoIP technology should first consult with the technologists supporting their existing traditional phone system and determine which functions are being actively used. This process must be approached as a blank slate, with the intent of fully documenting what the current phone system does behind the veil of comfortable, familiar reliability. Once this baseline functionality has been documented, the new VoIP system can be examined with an eye toward ensuring that all existing functions will be carried over, with appropriate trade-offs and adjustments where necessary.

Examination of the existing or traditionally assumed phone functionality may identify several classes of functionality. Some are “must have” items from the user’s perspective (e.g., voice quality), others may be required by policy (e.g., Emergency 911 geolocation), and still others are characteristics of VoIP (latency and jitter specifications) that don’t map neatly back to the old telephone system.

In all cases, the object of the examination is to fully characterize the old system and to consciously establish expectations for the new system. The goal is to work out all details beforehand, so that there are no moments of disappointed realization that the new system is not “just like the old phones,” once the VoIP is installed.

From a security standpoint this evaluation is doubly important in that many of the security assumptions regarding the old telephone system will no longer apply, while new security requirements will emerge. First, many of the security assumptions regarding the old telephone system relate specifically to the architecture of that system. Because the telephone system is connection-based, conversations were generally not physically available to other users. Control, billing, and switching attacks were somewhat difficult because of the largely “out of band” nature of the control substructure.

In a packet-switched system operating over common channels, the technique for tapping a conversation is significantly altered, because anybody can sniff the traffic over common lines. On the control side, the control signaling is often carried over the same infrastructure as the message links. In general, VoIP security requires much more extensive intervention to achieve the same basic level of security that was assumed with the traditional system, mainly because risk has shifted from physical access to virtual access.

Achieving higher levels of security is a mixed bag. In some instances, (e.g., encryption and intrusion detection), additional security may be provided by security measures that are already present in the data network. In other cases, VoIP implementation will be in conflict with existing data network security mechanisms (for example, many firewalls, and downgrader/guards).

In general, however, the introduction of VoIP into existing data networks will require development of selection criteria that take into account the effect on existing data network

security, the interaction between data network security and VoIP, and new classes of attacks and security issues that will arise from the co-location of both functions on the same infrastructure.

The following paragraphs address some technology specifics, and the implications those specifics have for the security practitioner.

## 5.4.5.2 SIP

Session Initiation Protocol (SIP) is a text-based protocol, like Simple Mail Transfer Protocol (SMTP) and Hypertext Transfer Protocol (HTTP), for initiating interactive communication sessions between users [1]. Such sessions include voice, video, chat, interactive games, and virtual reality. SIP is the protocol used to set up conferencing, telephony, multimedia, and other types of communication sessions on the Internet [2].

SIP is described as a control protocol for creating, modifying, and terminating sessions with one or more participants in an IP-based network. These sessions include Internet multimedia conferences, Internet (or other IP network) telephone calls, and multimedia distribution. Members in a session can communicate via multicast, through a mesh of unicast relations, or by a combination of these. SIP supports session descriptions that allow participants to agree on a set of compatible media types. It also supports user mobility by proxying and redirecting requests to the user's current location. SIP is not tied to any particular conference control protocol [4]. Figure 5.4-1 illustrates a typical SIP network and the different information flows involved in a SIP call.

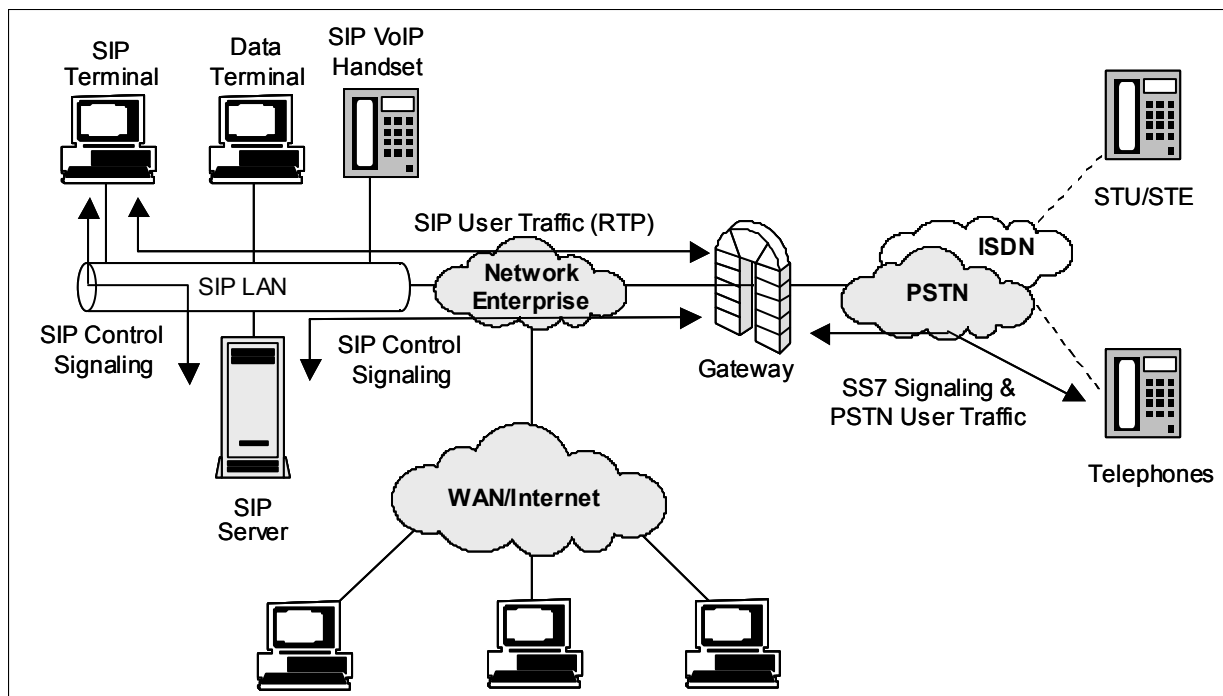

iatf\_5\_4\_1\_5401

Figure 5.4-1. SIP Network

To provide telephony services, a number of standards and protocols must come together. Real-Time Transport Protocol (RTP) is used. RTP is an Internet protocol for transmitting real-time data such as audio and video. RTP consists of a data and a control part. The latter is called Real-Time Transport Control Protocol (RTCP). In addition, a mechanism is needed for guaranteeing voice quality (for instance, Resource Reservation Setup Protocol [RSVP] or Yet another Sender Session Internet Reservations [YESSIR]). An authentication method is also needed with SIP (see Section 5.4.5.7.4).

Currently, SIP is a draft, proposed as standard RFC 2543, from the Internet Engineering Task Force (IETF), the body responsible for administering and developing the mechanisms that make up the Internet. The main work of the IETF's SIP working group involves bringing SIP from proposed to draft standard, in addition to specifying and developing proposed extensions that arise from strong requirements. The SIP working group will not explore the use of SIP for specific environments or applications. It will, however, respond to general-purpose requirements for changes to SIP provided by other working groups, including the Session Initiation Protocol Project INvestiGation (SIPPING) working group, when those requirements fall within the scope and charter of SIP [1]. The SIPPING working group has the more focused goal of documenting the use of SIP for several applications related to telephony and multimedia, and developing requirements for any extensions to SIP needed for those applications.

### 5.4.5.3 H.323

The H.323 standard is a cornerstone technology for the transmission of real-time audio, video, and data communications over packet-based networks. It is an umbrella standard that specifies the components, protocols, and procedures that provide multimedia communication over packet-based networks that do not provide a guaranteed quality of service (QoS). H.323 can be applied in a variety of mechanisms: audio only (IP telephony); audio and video (video telephony); audio and data; and audio, video, and data. H.323 can also be applied to multipoint multimedia communications.

The H.323 standard is specified by International Telecommunication Union (ITU)-T Study Group 16 and is currently in version 4. Version 1 of the H.323 recommendation titled, "visual telephone systems and equipment for local area networks (LANs) that provide a nonguaranteed QoS," was accepted in October 1996. It was, as the name suggests, heavily weighted toward multimedia communications in a LAN environment. The emergence of VoIP applications and IP telephony paved the way for a revision of the H.323 specification. With the development of VoIP, new requirements emerged, such as providing communication between a PC-based phone and a phone on the PSTN. Such requirements expanded the need for a standard for IP telephony.

Version 2 of H.323, packet-based multimedia communications systems, was defined to accommodate the additional requirements; this version was accepted in January 1998. New features in version 2 included call hold, call park and pickup, call waiting, message waiting, and some fax and multimedia broadcasting capability. These features basically map voice calls over IP and standardize call connections, allowing calls from different systems to interoperate.

## UNCLASSIFIED

Security for Voice Over Internet Protocol  
IATF Release 3.1—September 2002

Version 3 of the standard added fax-over-packet networks, gatekeeper-gatekeeper communications, and fast-connection mechanisms. Among other features, these mechanisms provided for better performance and preserved system resources by enabling an endpoint to specify whether it has the ability to “reuse” a call signaling connection and whether it can support using the same call signaling channel for multiple calls. This capability is particularly important for gateways that may have thousands of calls running simultaneously. By using these two features, a gateway can maintain a single Transmission Control Protocol (TCP) connection between itself and the gatekeeper to perform all call signaling [5].

Version 4 contains enhancements in several important areas, including reliability, scalability, and flexibility. H.323 has a strong market in voice, video, and data conferencing on packet networks; version 4 makes strides toward keeping H.323 ahead of the competition [6], although version 4 is not widely implemented [7].

The IETF standards are interoperable with the ITU-T standards on the voice transport level because ITU-T incorporated IETFs RTP protocol in its H.323 umbrella standard. However, the two institutions propose different signaling protocols: ITU-T uses the H.323 standard (“visual telephone systems and equipment for local area networks which provide a nonguaranteed quality of service”), whereas IETF pushes the SIP signaling. Currently, there are many discussions and predictions about which approach will gain greater popularity [7].

A primary goal of the H.323 standard is interoperability with other multimedia-service networks. This interoperability is achieved through the use of a gateway, which performs any network or signaling translation required for interoperability.

The H.323 standard specifies four distinct components, which when networked together, provide point-to-point and point-to-multipoint multimedia communication services. These components are—

- Terminals.
- Gateways.
- Gatekeepers.
- Multipoint control units (MCU).

The gatekeepers, gateways, and MCUs are logically separate components of the H.323 standard but can be implemented as a single physical device.

### **5.4.5.3.1 Terminals**

Terminals are used for real-time bidirectional multimedia communications. An H.323 terminal can be either a personal computer (PC) or a stand-alone device, running H.323 and the multimedia applications. It supports audio communications and can support video or data communications. A primary goal of H.323 is working with other multimedia terminals. In pursuit of this goal, H.323 terminals must support the following standards and protocols:

- **H.245.** An ITU standard used by the terminal to negotiate its use of the channel. The H.245 control channel provides in-band reliable transport for capabilities exchange, mode preference from the receiving end, logical channel signaling, and control and indication.
- **H.225.0.** An ITU standard that uses a variant of Q.931 to set up the connection between two H.323 endpoints.
- **Registration Admission Status (RAS).** A protocol used to communicate with the H.323 gatekeeper.
- **RTP and Real-Time Control Protocol (RTCP).** Protocols used to sequence the audio and video packets. The RTP header contains a time stamp and sequence number, allowing the receiving device to buffer as much as necessary to remove jitter and latency by synchronizing the packets to play back a continuous stream of sound. RTCP controls RTP, gathers reliability information, and periodically passes this information on to session participants [8].

### 5.4.5.3.2 Gateways

A gateway connects two dissimilar networks (e.g., an H.323 network and a non-H.323 network). For example, a gateway can connect and provide communication between an H.323 terminal and a terminal on the PSTN. This connectivity is achieved by translating protocols for call setup and release, converting media formats between different networks, and transferring information between the networks connected by the gateway. A gateway is not required, however, for communication between two terminals on an H.323 network.

### 5.4.5.3.3 Gatekeepers

A gatekeeper can be considered the brain of the H.323 network. It is the focal point for all calls within the network. Although they are not required, gatekeepers provide important services, such as addressing, authorization, and authentication of terminals and gateways; bandwidth management; accounting; billing; and charging. Gatekeepers can also provide call-routing services.

### 5.4.5.3.4 Multipoint Control Units

MCUs provide support for conferences of three or more H.323 terminals. All terminals participating in the conference establish a connection with the MCU. The MCU manages conference resources and negotiates between terminals to determine the audio or video coder/decoder (CODEC) to use, and it may also handle the media stream.



## 5.4.5.4 Media Gateway Control

The Media Gateway Control Protocol (MGCP) specifies communication between call control elements and telephony gateways. It was conceived partly to address some of the perceived inadequacies of H.323 at the level of centralized network infrastructure. MGCP, in its current form, is a combination of two earlier protocols, Simple Gateway Control Protocol (SGCP) and IP Device Control (IPDC) [11]. The IETF, through its Media Gateway Control (Megaco) Working Group, is working on a standard to replace MGCP; this new standard will use the same architecture and baseline as MGCP but will support asynchronous transfer mode (ATM) [11].

Megaco RFC 3015 (also published as ITU-T Recommendation H.248) was developed by the IETF Megaco Working Group in close cooperation with ITU-T Study Group 16. Megaco addresses the relationship between the Media Gateway (MG) and the Media Gateway Controller (MGC) by standardizing the interface between the Call Control entity (MGC) and the Media Processing entity (MG) in the decomposed Gateway architecture [10]. The MG converts media provided in one type of network to the format required in another type of network, while the MGC controls the parts of the call state that pertain to connection control for media channels in a MG. Megaco may be integrated into such products as central office switches, gateways (trunking, residential, and access), network access servers, cable modems, PBXs, IP phones, and soft phones to develop a convergent voice and data solution [10].

### 5.4.5.4.1 Relationship between Media Gateway Control and H.323 or SIP

MGCP is a complementary protocol to both SIP and H.323 [16]. MGCP and the newer Megaco are designed specifically as internal protocols for traffic between MGCs and MGs for decomposed gateway architectures. H.323 and SIP protocols handle call signaling between MGCs or other H.323 entities (gatekeepers and endpoints). An MGC handles call processing by interfacing with the IP network via communications with an IP signaling device, such as an H.323 gatekeeper or an SIP server and with the circuit-switched network via an optional signaling gateway [16]. The MGC implements the signaling layers of H.323 and presents itself as an H.323 gatekeeper or as one or more H.323 endpoints. MGs focus on the audio signal translation function, converting the audio signals carried on telephone circuits and data packets carried over the Internet or other packet networks [16]. Thus, the Megaco and MGCP protocols complement both H.323 and SIP protocols by providing support for multipoint, multimedia calls at the media level. Figure 5.4-2 illustrates the relationship between the MGCs, MGs, and the signaling protocol.

## 5.4.5.5 Voice over ATM

Asynchronous Transfer Mode, or ATM is a multiservice, high-speed, scalable technology. It is a dominant switching fabric in carrier backbones, supporting services with different transfer characteristics. ATM simultaneously transports voice, data, graphics, and video at very high speeds.

Large enterprises increasingly desire broadband connectivity to the wide area network (WAN) for headquarters and main offices. ATM is one way to provide a broadband connection to accommodate these enterprises' vast amounts of voice and data transmissions, such as heavy graphics, payroll information, and voice and video conferencing.

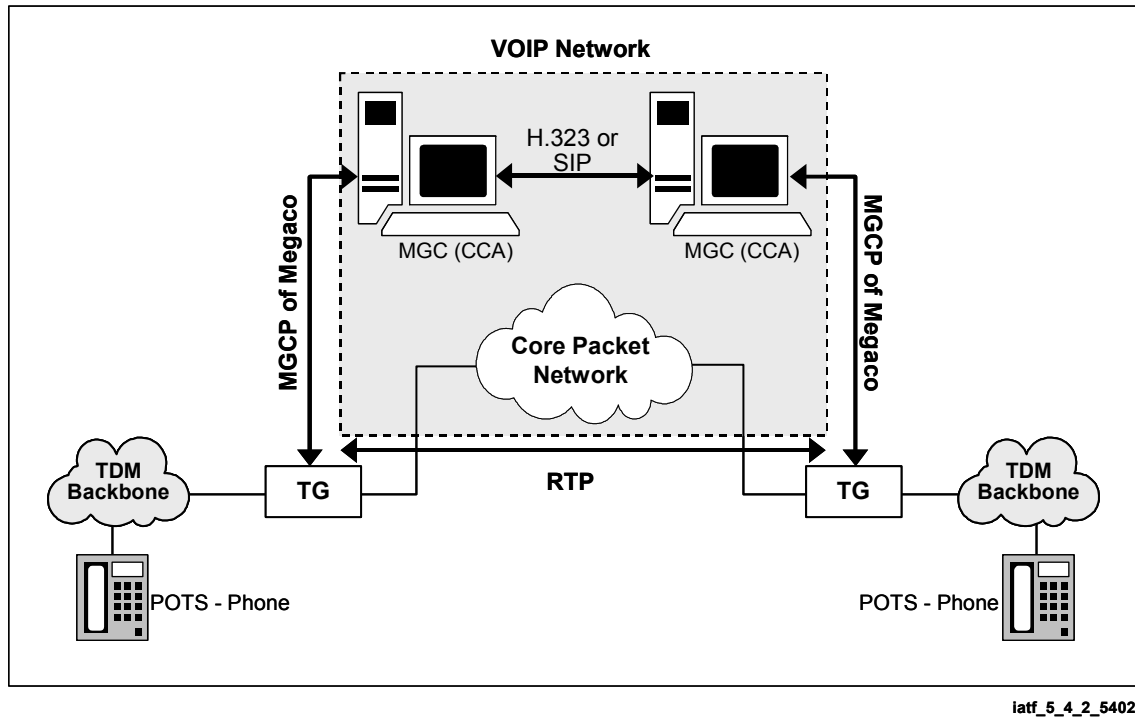

**Figure 5.4-2. Relationship Between Media Gateway Control Protocol and H.323 or SIP**

ATM networks have the ability to negotiate a traffic contract at connection establishment. For a voice connection, a traffic contract can be negotiated to meet the specific requirements of the connection. In addition, ATM protocols include an ATM adaptation layer (AAL 2) specific to voice. These characteristics make ATM an ideal network for carrying voice traffic. On the down side, ATM services are expensive and are not universally available. Most networks today do not have ATM protocols running from end terminal to end terminal. Instead, ATM is usually used as a backbone or technology to transport IP packets or other network traffic. For voice communications, QoS must be provided end to end. This means that the protocol running over ATM, as well as the ATM network, must establish a traffic contract that can support the voice connection. A voice over ATM architecture is illustrated in figure 5.4-3.

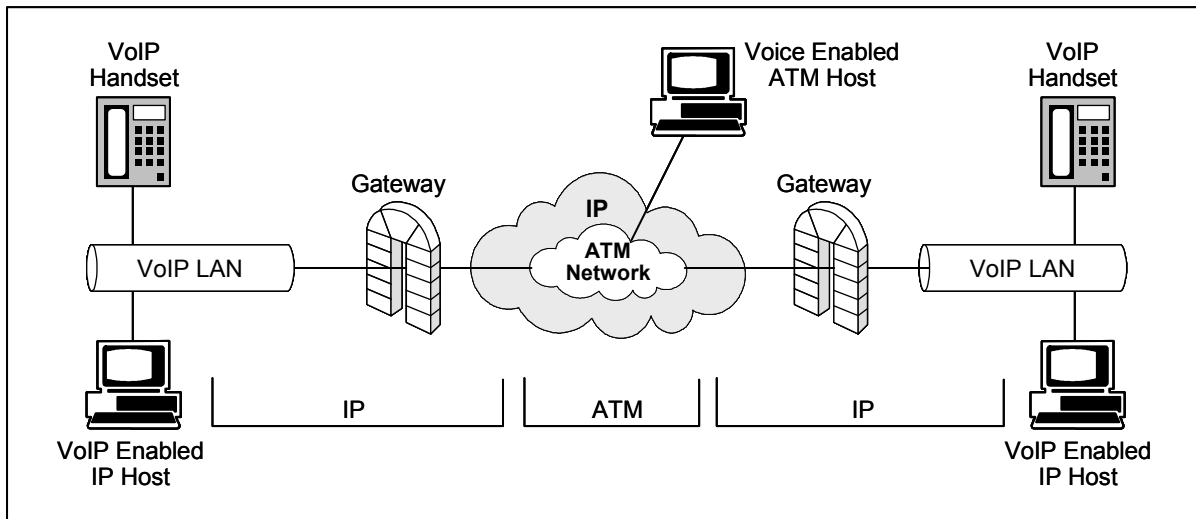
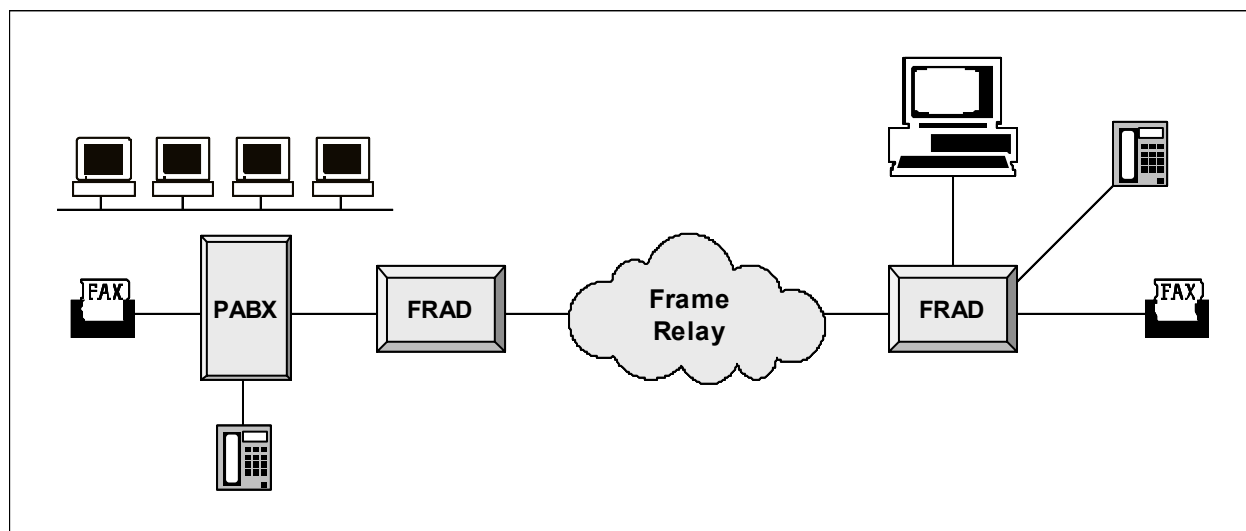

Figure 5.4-3. Voice over ATM

### 5.4.5.6 Voice over Frame Relay

Of the three packet/cell technologies (frame relay, IP and ATM), frame relay is the most widely deployed. Frame relay is commonly used in corporate data networks because of its flexible bandwidth, widespread accessibility, support of a diverse traffic mix, and technological maturity [12]. Initially, frame relay gained acceptance as a means of providing end users with a solution for LAN-to-LAN connections and other data connectivity requirements. In addition to providing a flexible and efficient data transport mechanism, frame relay lowered the cost of bandwidth for tying together multiprotocol networks and devices [14]. Often, it is used as a transport protocol linking two or more IP networks. Although frame relay does specify a minimum throughput for each connection, it does not support a rich QoS scheme. However, it has better QoS characteristics than IP networks and is used to carry both voice and data connections today. A voice over Frame Relay architecture is illustrated in figure 5.4-4.



iatf\_5\_4\_4\_5404

**Figure 5.4-4. Voice over Frame Relay**

Frame relay service is based on permanent virtual connections (PVC). The technology is appropriate for closed user groups and is also recommended for star topologies and situations in which performance must be predictable. VoFR is a logical progression for organization's already running data over frame relay [12].

Sometimes, congestion can occur in frame relay networks; this typically results in being dropped. Because voice connections are less tolerant of dropped frames than are data connections, too many dropped frames can have disastrous effects with voice traffic. There are mechanisms for traffic management in frame relay networks to mitigate congestion conditions. With the ratification of the frame relay forum's (FRF) FRF.11, a standard was established for frame relay voice transport. The Frame Relay Forum Technical Committee developed the Implementation Agreement FRF.11 to define standards for how vendor equipment interoperates to transport of voice across a carrier's public frame relay network.

## 5.4.5.7 Security Issues with Protocols and Equipment

### 5.4.5.7.1 H.235

H.235 is the security portion of the H.323 standard prepared by ITU-T Study Group 16. Its purpose is to provide for authentication, confidentiality, and integrity within the current H-Series protocol framework [13]. In addition to protecting voice traffic itself, H.235 provides protection for Q.931 (call setup), H.245 (call management), and Gatekeeper Registration/Admission/Status (RAS). Version 2 of H.235 supersedes H.235 version 1, featuring several improvements, such as elliptic curve cryptography, security profiles (simple password-based and sophisticated digital signature), new security countermeasures (media anti-spamming), support for the Advanced Encryption Algorithm (AES), support for backend service, definition of object identifiers, and incorporated changes from the H.323 implementers guide [13].

### **5.4.5.7.1.1 H.235 Authentication**

Authentication may be provided in conjunction with the exchange of public-key based certificates. It may also be provided by an exchange that uses a shared secret between the entities involved. This may be a static password or some other a priori piece of information, such as shared secret key methods based on Diffie-Hellman key exchange [13]. H.235 also describes the protocol for exchanging certificates but does not specify the criteria by which the certificates are mutually verified and accepted. The intent behind the certificate exchange is to authenticate the user of the endpoint, not simply the physical endpoint [13]. The authentication framework in H.235 does not prescribe the contents of certificates (i.e., does not specify a certificate policy) beyond that required by the authentication protocol. However, an application using this framework may impose high-level policy requirements, such as presenting the certificate to the user for approval [13].

For authentication that does not use digital certificates, H.235 provides the signaling to complete various challenge-response scenarios. This method of authentication requires prior coordination by the communicating entities so that a shared secret can be obtained [13]. As a third option, the authentication can be completed within the context of a separate security protocol, such as TLS or IPsec [13].

### **5.4.5.7.1.2 Confidentiality**

H.235 articulates a media encryption mechanism for voice streams carried on packet-based transports, to provide confidentiality. Its first step toward this goal was providing an encrypted channel on which to establish cryptographic keying material and/or set up the logical channels, which will carry the encrypted voice streams [13]. For this purpose, when operating in a secure conference, any participating endpoints can use an encrypted H.245 channel. This channel allows cryptographic algorithm selection and encryption key commands to pass protected. If the H.245 channel must be operated in a nonencrypted manner, the specific media encryption keys can be encrypted separately in the manner signaled and agreed to by the participating parties [13]. The confidentiality of the data is based on end-to-end encryption. Confidentiality can be ensured between endpoints only if connections between the trusted elements are proven using authentication.

### **5.4.5.7.2 IPsec**

IPsec was designed to provide interoperable, cryptographically based security for IPv4 and IPv6. The set of security services includes access control, connectionless integrity, data origin authentication, protection against replays, confidentiality, and limited traffic flow confidentiality. These services are provided at the IP layer, offering protection for IP and/or upper layer protocols. Thus, IPsec can be used to protect both VoIP signaling (i.e., SIP and H.323) and VoIP user traffic (i.e., RTP).

IPsec uses two traffic security protocols, the Authentication Header (AH) and the Encapsulating Security Payload (ESP), which use cryptographic key management procedures and protocols.

ESP has been widely embraced by industry and there are multiple implementations available. However, AH has not been so widely accepted. ESP can provide an authentication service. While AH has the added benefit of authenticating some of the fields in the IP header, this is not seen as a significant advantage. The key management and security negotiation for IPsec is handled through IKE. IKE is used to establish key material and a security association to be used by ESP.

To use IPsec to protect VoIP traffic, security associations must be established between VoIP components that will communicate. This implies a mesh of security associations. Depending on the number of communicating entities, there can be a large number of IPsec SAs. IPsec can be applied to protect most protocols used with VoIP. It is applied at the network layer, whereas most protocols used with VoIP exist above the network layer (i.e., VoIP signaling at the application layer).

### **5.4.5.7.3 Megaco**

The Megaco standard does not have any security features built into the protocol. It depends on the underlying protocols to provide authentication of the source of communications and security of the content. For VoIP communications, the standard recommends using IPsec's AH to validate the source of packets and the integrity of packets between the MG and the MGC. AH can also be used to protect against replay attacks. IPsec's ESP can be used to protect the confidentiality of the communications between the MGC and the MG, particularly if session keys are to be transmitted in the session descriptions from the MGC to the MG to encrypt audio messages.

In practice, AH is rarely used. Instead, ESP is used to provide authentication and well as integrity and confidentiality. ESP can be employed to build a secure tunnel between the MG and the MGC. This tunnel can then be used to protect all Megaco traffic. Typical networks have only a few MGs and MGCs, which will not create a scaling problem when provisioning the IPsec tunnels.

### **5.4.5.7.4 SIP Security**

The current SIP Internet Draft specifies the same authentication scheme as HTTP. SIP authentication is between a user agent client and a user agent server. Although one application may act as both client and server, the authentication is usually not end-to-end (i.e., user-to-user). Instead, authentication is usually between a user and a server or between two servers. For conference calls, there must be a conference control application to which all participants in the conference must authenticate.

There are two SIP authentication schemes: Basic Authentication and Digest Access Authentication. Basic Authentication transmits passwords in clear text and should not be considered. Digest Access Authentication is a basic challenge-and-response mechanism. The server issues a challenge to the client containing a nonce. A valid response from the client must contain an MD5 hash of the user name, the password, the given nonce, and the request SIP-URL

## UNCLASSIFIED

Security for Voice Over Internet Protocol  
IATF Release 3.1—September 2002

(i.e., user address). This authentication scheme is designed for the client to authenticate to the server, not for the server to authenticate to the client. No provision is made for the initial secure arrangement to user and server of the user's password. Digest Access Authentication is not as secure as a public key authentication or Kerberos authentication.

This authentication scheme specified by SIP should not be confused with the HTTP authentication scheme implemented in commercial browsers. Browsers use the authentication scheme specified by TLS or Secure Socket to Layer (SSL), which is different from the authentication scheme described here.

SIP specifies PGP to provide integrity and confidentiality. The default integrity algorithm for SIP is SHA-1, but MD-5 is also specified. Integrity is provided on a SIP flow across the entire SIP message, but excluding the IP header. SIP flows are usually server to server (proxy server or user agent server) or user to server.

The SIP working group in the IETF has recognized the inadequacy of these provisions. As a result, the SIP working group is defining a security architecture. At present, no time frame has been established for the availability of this new security architecture.

SIP security requires mutual authentication to ensure that both parties are who they claim to be. A mechanism such as JTLS or SSL should not be used alone because these only perform a one-way authentication, typically server to client. In the case of VoIP, both client-to-server and server-to-client authentication are important. SIP security also requires integrity, to ensure that messages are not modified, and confidentiality, to protect against traffic analysis attacks.

An interim solution for SIP security—until the new security architecture is developed by the IETF—is to build protected tunnels between SIP clients and servers. These tunnels could be built using IPsec. SIP servers would require an IPsec SA between each pair of servers. SIP clients would initiate an SA between themselves and their SIP server when they want to make a VoIP call. Each server would communicate to other servers within the network using preestablished SAs. Finally, the servers serving the destination user would initiate an IPsec SA to the destination user for the last leg of the signaling. These IPsec SAs are not user to user. Therefore, they could not be used to protect the RTP stream carrying voice traffic between users. A new IPsec SA is required to be established between users to protect the RTP stream.

### 5.4.5.7.5 Firewall Considerations

The Real-Time Transport Protocol (RTP) that is used by both SIP and H.323 for carrying VoIP user traffic through the network uses a wide range of ports—10,025 to 65,000—to transport user packets. This makes it difficult to restrict firewall ports to specific types of traffic. VoIP uses four TCP ports per VoIP connection, two for signaling (forward and reverse channel) and two for transport of user information (forward and reverse channel). RTP also typically has been implemented using User Datagram Protocol (UDP), which is commonly blocked at firewalls because it is not connection oriented and is used by streaming applications that consume large quantities of bandwidth. Clearly, opening ports 10,025 to 65,000 and allowing all UDP traffic would severely compromise the security of the network.

There are currently two configurations for overcoming VoIP's firewall issue. The first is dynamic port mapping. This feature may not be offered by all router vendors and operates in a slightly different way with each vendor implementation. The filtering router fronting the firewall receives a VoIP connection that may be on any port between 1,025 to 65,000. The router changes the port to a small range of ports through which the firewall is configured to allow VoIP traffic to pass. This limits the number of ports that must be open on the firewall. However, because four ports are required per VoIP call, the number of open ports can grow quickly if even a moderate number of VoIP users must be supported.

The second configuration is static mapping. In this case, each VoIP user is assigned to a group of four ports on the firewall, which will be used only for a VoIP call that a designated VoIP user initiates. This option requires considerable manual configuration. Each time a VoIP user is added or removed, the configuration must change.

With VoIP, as with many other protocols, the firewall cannot by itself stop an attack that takes the form of an allowed protocol on an approved port. In addition, the need to limit delay will affect the use of intrusion detection systems (IDS) or other filtering and detection mechanisms. This may be an area for future research, to find a means of achieving the same level of protection against malicious code and covert channels in the conveyed network environment that is expected in a data environment.

Another issue involved in using VoIP through a firewall concerns Network Address Translations (NAT). Frequently firewalls use NAT to provide additional security and to allow the use of private addresses within an organization's intranet. The problem with using SIP and NAT together is that the SIP User Resource Locator (URL) addresses can be located in multiple locations in the SIP header (e.g., Request line, the TO field, the FROM field, the VIA field, the Contact field, the Record-route field, the Route field, and the last part of the Call-ID field). The firewall or application server on the public side of the firewall must be intelligent enough to translate all of these address fields into public addresses or to translate public addresses to private addresses if the packet is going into the intranet.

### **5.4.5.7.6 Secure Voice Interoperability (STE/STU/ Wireless)**

STE and STU are approved for carrying secure voice traffic over PSTN and ISDN networks. However, even if a site no longer maintains PSTN or ISDN service, its secure voice requirements will still mandate the use of STEs and STUs to work over the VoIP infrastructure. Therefore, sites will need to carry STE and STU traffic over the packet-based VoIP network.

STE performs its security signaling within the ISDN B channel and does not perform any customized signaling in the ISDN D channel. Therefore, if an ISDN card is installed in a VoIP-capable router, the STE call can proceed transparently to the transport technology. STE users can be connected to an ISDN-capable router and complete secure calls to other STE or STU users. They can also complete nonsecure calls to VoIP users. However, STE users will not be able to complete a secure call to a VoIP user.



STU interoperability is identical to that for STE. If a PSTN interface is provided by a VoIP router, STU signaling can be carried transparently by the VoIP network. STU users can complete secure calls to other STU users across a VoIP infrastructure and nonsecure calls to VoIP users.

A secure wireless terminal uses a customized security signaling protocol for security, called Future Narrow Band Digital Terminal (FNBDT). FNBDT signaling runs at the application layer and can be carried transparently over a VoIP network. Secure wireless users can complete non-secure calls over a VoIP network. They can also complete secure calls to other secure wireless users or to users of a terminal (e.g., STE) that is FNBDT enabled.

The scenarios described for STE, STU, and secure wireless interoperability assume that there is a connection between the enterprise VoIP network and the PSTN.

#### **5.4.5.7.7 Signaling System 7 Security Issues**

Enterprise VoIP networks will require connectivity to a wide area PSTN to allow VoIP users to communicate with PSTN users. This connectivity requires that the VoIP control plane interoperate with the PSTN control plane. The PSTN control plane is based on Signaling System 7 (SS7). One of the basic design considerations for SS7 was that it would be a closed network, and PSTN users would not have access to the SS7 network. However, connecting a packet-based VoIP network to the PSTN opens up connectivity between nodes on the enterprise IP network and the SS7 network.

#### **5.4.5.7.8 Performance Considerations**

VoIP technologies are very sensitive to jitter, latency, and other network parameters. Therefore, the network must be properly provisioned. There must be sufficient bandwidth and network resources available in the enterprise to accommodate the increased demands of VoIP traffic. An improperly provisioned network may provide degraded service for both VoIP and existing data applications. In addition, the network must have a QoS policy in place. Part of the QoS policy may mandate the use of Diff Serv, MPLS, RSVP, or another QoS mechanism. These QoS mechanisms also require security. It is possible for an unauthorized user to use QoS mechanisms to reserve a large portion of the network bandwidth or resources, leaving little or no resources available for other applications.

QoS protocols do not have adequate security functionality built into them. Although, some protocols (e.g., RSVP) have an integrity checksum, which also provides some limited authentication, confidentiality, key management, and a strong authentication mechanism are also required.

Because of QoS protocols' lack of security, the current best security recommendations for these protocols in the enterprise are to restrict access to the network to authorized individuals and to implement good personnel security. Good access control and authentication mechanisms should be used to in place to limit access to the routers. It is possible to limit access to QoS protocols in

an enterprise network that is owned, operated, and used by the same organization. However, this recommendation is not feasible in a network in which services may be leased and shared by other organizations (i.e., a WAN).

Bandwidth and performance that may have been acceptable for data applications may not be acceptable for voice. Today, most networks do not have QoS mechanisms. Therefore to accommodate the increased timeliness demands of voice, overprovisioning may be necessary. Overprovisioning, in concert with good traffic management, can provide an acceptable interim solution until QoS mechanisms can be deployed.

## 5.4.6 Cases

### 5.4.6.1 Integrating a VoIP Capability with an Existing Infrastructure

This scenario considers a case in which an enterprise network that has been used to carry data applications is augmented to carry voice traffic. It is assumed that the network is owned and operated by a single organization and that the organization manages the network and has authority to perform upgrades. The circuit-switched network used by the organization may be phased out entirely, or a small circuit switched capability may remain. The organization expects the same voice quality and reliability for voice traffic over the packet-switched network that it has expected from the circuit-switched voice network. Connectivity to the PSTN will be maintained. The organization also assumes that performance for existing data applications will not suffer. An additional assumption is that there is no QoS on the network. All traffic is best effort. This scenario is illustrated in figure 5.4-5.

The first step in this scenario is to determine what additional bandwidth requirements the voice applications will place on the network. The existing network may be capable of meeting the demands of data applications; however, additional bandwidth for the enterprise network and for external connectivity will be required to support voice service. It is unwise to simply add voice service to an existing network without understanding the additional stresses. Voice applications are less tolerant to delay, jitter, and other QoS parameters. Levels of performance that had been acceptable for a data network may fall short for use of a voice application. Typically, access links are the points at which most network congestion occurs. Additional voice traffic will put additional stress on these links, and they must be augmented accordingly.

Some organizations may want to maintain a limited circuit-switched phone system for emergency use. The packet network will be subject to increased stress during emergencies. In addition, attacks and viruses that may degrade the performance of the network will also now degrade the performance of the voice service. A limited circuit-switched capability can aid in the recovery efforts of the packet network, if degraded performance occurs.

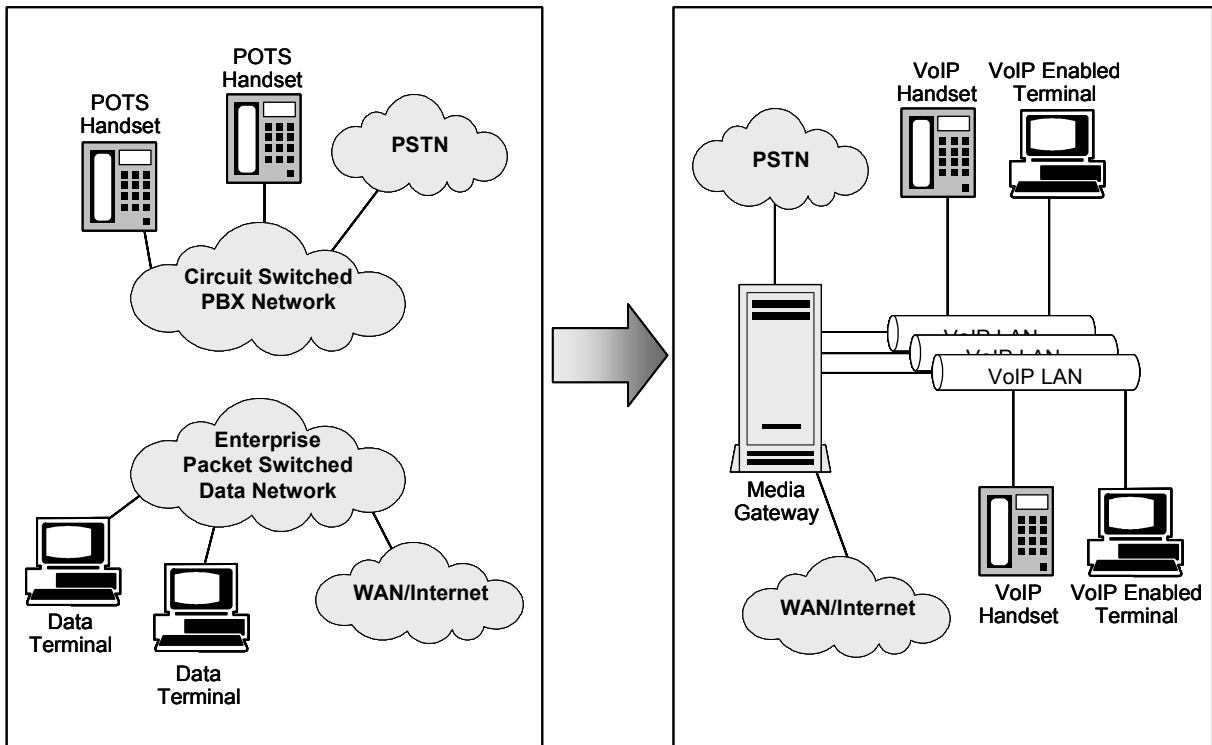

iatf\_5\_4\_5\_5405

**Figure 5.4-5. Integrating a VoIP Capability onto an Existing Network**

Many of the protocols that are required to support VoIP are not hardened. Therefore, VoIP security for an enterprise environment must rely heavily on physical security, controlling access to network devices, and personnel security. All network management traffic to VoIP network components should be protected with confidentiality, integrity, and authentication.

To protect VoIP signaling information, tunnels using IPsec can be created between VoIP enclaves, between VoIP users and VoIP servers, and between VoIP servers. Protection is not possible for communications between all external entities. However, calling patterns can be analyzed to determine which organizations frequently communicate. An IPsec tunnel can then be established between these organizations to pass VoIP signaling information.

When a call is placed between a VoIP user and a PSTN user, the security provided by an IPsec tunnel will stop at the PSTN gateway. For protection of calls between VoIP users and PSTN users, the PSTN gateway must be hardened. Management access to the gateway must be limited and protected. The router fronting the gateway should be configured to filter addresses that are not authorized to use or access the gateway. Management traffic between the gateway and the management station should be protected with confidentiality, integrity, and authentication. Protection of the gateway from the SS7 side will require further study.

## 5.4.6.2 Building a VoIP Capability

This scenario addresses a case in which a new network is being created to handle voice, video, data, and other multimedia traffic. It is assumed that the network is owned and operated by a single organization and that the organization manages the network and has authority to perform upgrades. There will be either no circuit-switched voice network installed or a very limited service to accommodate mission-critical applications. The organization expects the same voice quality and reliability for voice traffic that is expected from a circuit-switched voice network. This scenario assumes that there is no QoS on the network. All traffic is best effort.

In building a new network that will carry both VoIP traffic and traditional data traffic, a network designer must consider the bandwidth demands voice will place on the network. Faster network protocols, such as Fast Ethernet and Gigabit Ethernet, should be considered for the enterprise network. Although protocols such as these may not have integrated QoS, they may be more effective for voice just because of their speeds. These protocols can also help provide over provisioning, which can be used to offset or compensate for the lack of QoS mechanisms.

Other than some flexibility with design considerations and bandwidth allocation, the security issues that apply in creating a new VoIP network are the same basically as those involved in adding VoIP service to an existing network. Thus, the same security recommendations apply to this scenario that applied to the previous scenario.

## 5.4.7 Framework Guidance

Perhaps the most important guidance that can be provided to those attempting to implement VoIP securely is that it is inherently a systems engineering task, rather than a matter of plugging in the various boxes. Although the realms of telephone systems and data networks are each well understood to a notable degree in regard to functionality and security, the intersection of these distinct systems in a converged VoIP environment creates three new sets of complications.

First, the convergence creates new risks for the phone aspect of the system. For example, wiretaps by agents other than by law enforcement are now relatively rare, because they require both physical access to the circuit in question and knowledge that is not widely available outside the telecommunications industry. It is not that implementing a wiretap is difficult, just that it is not a commonly known technique. However, once the shift to VoIP is accomplished the knowledge, tools, and access needed to monitor a phone conversation (e.g., packet sniffing tools, protocol information, and access to the packets themselves) will be far more available in the network environment. Placing a “wiretap” on a VoIP network is not necessarily easier than doing so in the traditional phone system. In fact, in many ways it is more complicated technically. In addition, “sniffing packets” is commonly accepted, having many legitimate uses. Thus, both the technical and the social barriers to wiretapping will much lower in a data network environment.

Similarly, the introduction of VoIP creates new risks for the existing data networks. An example of this might be the need to open ports in existing firewalls to allow VoIP traffic to go through

without adding delay. Clearly, this will leave new holes in the perimeter that may be exploited by intruders, or by malicious insiders. This problem is not insurmountable, but requires an awareness of the new dynamics created by the addition of VoIP.

Lastly, there will likely be some new class of vulnerability that is based on synergetic interaction between either the base technologies, or the security mechanisms that support them. Again, the proper attitude is not acceptance of lessened security, but rather an awareness that the convergence of these two previously independent technologies and infrastructures creates unanticipated complications and permutations that must be analyzed carefully and addressed. As yet, this is not a plug-and-play security situation, and this will probably be the case for some time, as is typical for any new technology. The early adopters will need to proceed with skill and caution to create viable solutions to their specific challenges.

## 5.4.8 Technology Gaps

The major technology gaps in the VoIP security realm are as follows:

- **Intrusion Detection.** Currently, there is little available capability to combine IDS monitoring of data and voice traffic. This situation is not so much the result of theoretical limitations as a consequence of the technology's still being in the early-adopter. Although, there are some IDS products designed for use on PBXs, we are still at the base of the learning curve in our understanding of the sorts of attacks that might piggyback on top of voice protocols, punch through the openings in firewalls that must be present for voice traffic to pass, or otherwise exploit vulnerabilities created by the convergence of voice and data on the same network. There will probably be a need to detect attacks and probes on both message traffic and control signaling portions of voice protocols and equipment. Both host-based and network based IDSs with this capability may be needed.
- **Identification and Authentication.** Given the reduced isolation of control signaling in VoIP compared with the traditional phone system, there is a need for a strong I&A capability to protect access to the control functions. This capability might be built into the equipment or might be a separate functionality positioned between the equipment and the network. I&A may also be needed to link a particular phone address to a user or location.
- **Encryption.** Although, existing crypto products can be used to provide trunk encryption, link encryption, or even end-to-end encryption, there will be a need for encryption functionality to be better integrated with and tuned to the specifics of VoIP usage, with special focus on reducing delay.
- **Firewalls, Guards, and Downgraders.** Each of these devices serves to separate an enclave from the outside world or the rest of the network. The need to limit latency, jitter, and delay necessitates a review of the design of these devices in the context of the converged network. The same openings that allow voice traffic to pass unimpeded may also either create high-bandwidth covert channels for data infiltration or exfiltration or

provide a point of entry for other probes and attacks. Although it may be impossible to examine voice traffic in real time without incurring unacceptable delay, it may be possible to isolate the voice traffic in some way from the rest of the network to minimize the vulnerabilities introduced by opening these entry points.

- **Integration.** It remains to be seen whether fully integrating voice with data is the best way to take advantage of packet-switched digital voice. It might be preferable to isolate the packet-switched digital voice on a separate network. In either case, well-thought-out systems engineering focused on the interactions and interdependencies of the whole system is the preferred approach rather than an ad hoc box-based mix-and-match solution focused on individual functions.
- **Graceful Degradation.** Although, a well-designed implementation of packet-switched voice will have factored uninterruptible power and fault tolerance into the plans, a converged network will still be a single point of failure in a way that totally separate data and telephone infrastructures were not. The security implications of this fact should be considered in whatever steps are taken to increase robustness and reliability.

## 5.4.9 Summary of Important Concepts

At this point in the evolution of VoIP, the key considerations are as follows:

- This is a new technology and, like any other new technology, involves a learning curve. This situation requires caution, and careful consideration of how one implements the technology. Be aware that unexpected vulnerabilities may be uncovered and that the technology may change course, rendering early implementations “nonstandard.” The same cautions apply to any efforts to secure the technology.
- Converging voice and data infrastructures is a systems engineering problem. The combination and interaction of previously isolated infrastructures, each with a distinct conceptual basis, will likely have at least some unintended results: some good, some harmless, some bad. Careful analysis of the system as a whole is crucial if the security risks are to be adequately identified, evaluated, and addressed.
- Voice connectivity is such a basic and widespread service that the pressure to attain a high level of functionality, even at the expense of security, will be greater than it might be in a less pervasive application. It is therefore critical that security be designed into the system to as great an extent as possible, so that it is not sacrificed later in a trade-off decision during system upgrades.
- Legal, regulatory, and policy issues may affect the design requirements of the system in unanticipated ways. It is therefore important to be aware both of current legal/regulatory/policy requirements and of those that are being proposed or discussed as you design your VoIP system.

## UNCLASSIFIED

Security for Voice Over Internet Protocol  
IATF Release 3.1—September 2002

### References

1. <http://www.ietf.org/html.charters/sip-charter.html>
2. <http://www.sipforum.org/>
3. <http://www.sipcenter.com/aboutsip/sip.htm>
4. <http://www.sipcenter.com/files/whatisip.pdf>
5. [http://www.packetizer.com/iptel/h323/whatsnew\\_v3.html](http://www.packetizer.com/iptel/h323/whatsnew_v3.html)
6. [http://www.packetizer.com/iptel/h323/whatsnew\\_v4.html](http://www.packetizer.com/iptel/h323/whatsnew_v4.html)
7. <http://iptel.org/info/trends/sip.html>
8. Overview of H.323, Cisco Gatekeeper External Interface Reference, version 3. Cisco IOS Release 12.2(2)XA
9. “Megaco and MGCP.” *Network Magazine*. October 5, 2000 (Doug Allen, senior editor, can be reached at [dougallen@cmp.com](mailto:dougallen@cmp.com)).
10. <http://www.hssworld.com/voip/stacks/megaco/megaco.htm>
11. Elachi, Joanna. Standards Snapshot: The State of the Big 3 in VoIP Signaling Protocols. November 27, 2000.
12. Gil Biran. Voice over Frame Relay, IP and ATM: The Case for Cooperative Networking. <http://www.protocols.com/papers/voe.htm>
13. International Telecommunication Union ITU-T H.235 Version 2 (11/2000)  
Telecommunication Standardization Sector of ITU
14. Frame Relay Forum: Market Development & Education Committee and Technical Committee, White Paper: A Discussion of Voice over Frame Relay, August 2000.
15. <http://www.frforum.com/>, The Basic Guide to Frame Relay Networking
16. <http://www.esoft.com.tw/product/mgcpo.htm>

## 5.5 Multiple Security Layers

Users are struggling to implement networks in which information of different classification levels are being transported over the same backbone. Users are using need-to-know to create communities of interest. The network is being relied on to provide data separation for each compartment. Guards that allow information to migrate from one compartment to another is a technology gap. Labels at the network layer, Closed User Groups (CUG), and encryption are all technologies being investigated to provide reliable data separation. A new section to be supplied in a later release of the framework.

This section will be provided in a later release of the framework.



**UNCLASSIFIED**

Multiple Security Layers  
IATF Release 3.1—September 2002

**This page intentionally left blank.**

## Chapter 6

# Defend the Enclave Boundary/ External Connections

---

An enclave is an environment under the control of a single authority with personnel and physical security measures. Enclaves typically contain multiple local area networks (LAN) with computing resource components such as user platforms; network, application, and communication servers; printers; and local switching/routing equipment. This collection of local computing devices is governed by a single security policy regardless of physical location. Because security policies are unique to the type, or level, of information being processed, a single physical facility may have more than one enclave present. Local and remote elements that access resources within an enclave must satisfy the policy of that enclave. A single enclave may span a number of geographically separate locations with connectivity via commercially purchased point-to-point communications (e.g., T-1, T-3, Integrated Services Digital Network [ISDN]) or using wide area network (WAN) connectivity such as the Internet.

The majority of enclaves have external connections to other networks. These external connections may be single-level connections, where the enclave and connected network are at the same privacy level, or the connection may be a High-to-Low/Low-to-High transfer, where the enclave is at a higher or lower level than the connected network. Enclaves may also have remote access connections to traveling users or users located in remote locations. The point at which the enclave's network service layer connects to another network's service layer is the enclave boundary. Figure 6-1 highlights the enclave boundary target environments within the high-level information infrastructure context. The placement of boundary protection mechanisms in Figure 6-1 is notional, representing only suggested, not necessarily actual, placement of information assurance (IA) components.

Defense of the enclave boundary is focused on effective control and monitoring of data flow into and out of the enclave. Effective control measures include firewalls, guards, virtual private networks (VPN), and identification and authentication (I&A)/access control for remote users. Effective monitoring mechanisms include network-based intrusion detection systems (IDS), vulnerability scanners, and virus detectors located on the LAN. These mechanisms work alone, and in concert with each other, to provide defenses for those systems within the enclave that cannot defend themselves or could be undermined by failures in systems operating at lower security levels or with less stringent security policies. Although the primary focus of the perimeter is on protecting the inside from the outside, enclave boundaries also provide some protection against malicious insiders who use the enclave to launch attacks or who facilitate outsider access through open doors or covert channels.

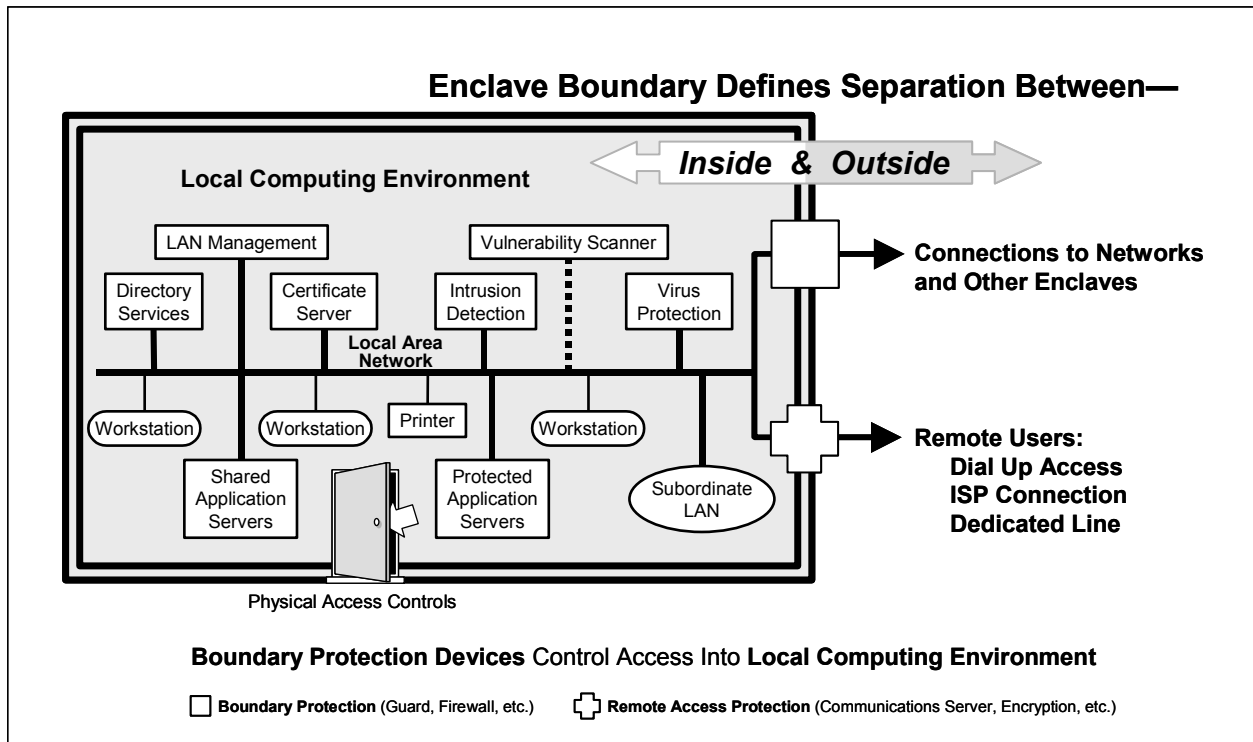

**Figure 6-1. Defend the Enclave Boundary**

The IA strategy for defending an enclave boundary includes a number of general defensive measures and specific capabilities that address remote access and interoperability across security levels. In general, the enclave perimeters must be established and must be equipped with professionally managed electronic access portals that enable effective control and monitoring. These portals should enable dynamic throttling of services in response to changing information conditions (INFOCON). They should establish mandatory Department of Defense (DoD) policy on the protocols that are allowed and disallowed between secure enclaves and external systems.

The strategy mandates the use of basic intrusion detection for all DoD enclaves, with additional detection mechanisms for mission-critical and mission-essential enclaves. VPNs, used to establish communities of interest (COI) (or intranets) will not be used between enclaves that provide different degrees of security, unless other adequate measures are used to protect the stronger enclave from the weaker one. An important strategy consideration is not losing detection capabilities when increasing the use of encryption. This requires that protection and detection capabilities be planned together. For VPNs, the DoD strategy is to install the VPNs in such a way that network-based monitors can be placed on their clear-text side.

Within the IA strategy, systems and enclaves that are provided with remote access to a secure enclave must comply with the security policy of the secure enclave. The remote enclave or system must comply with approved remote access protocols, be authenticated at the enclave perimeter, and ensure that the entire secure enclave is not jeopardized by overrun of remote access points. In all cases, remote access will require authentication using approved techniques.

## UNCLASSIFIED

Defend the Enclave Boundary/External Connections  
IATF Release 3.1—September 2002

At a minimum, this means using nonreusable passwords, preferably in encrypted form, or public key-based approaches.

Continuous authentication (versus authentication only at the beginning of a session) is preferred. For interoperability across security levels, the DoD infrastructures will be based on a multiple-security-level strategy in which separate system and network infrastructures are maintained at each security level. The use of devices that control data transfers across security levels will be minimized. When required by operational necessity, these shall be implemented by an official Secret and Below Interoperability (SABI) (or Top Secret and Below Interoperability [TSABI]) process. High-side servers that serve as gateways to receive Low-to-High transfers will use operating systems that are capable of enforcing user-level access controls, are properly configured and operated using the concept of least privilege, and include other appropriate layers of protection (including tripwires for protection against malicious software, preplaced forensics, reporting of incidents and anomalous activity, and host-based auditing).

The Defend the Enclave Boundary/External Connections chapter of the framework addresses the role of IA technologies in providing protection for the enclave. The Firewall section explores ways of protecting internal information systems from external attacks. While the Remote Access section reviews methods for users to securely access their LANs, the Guards section addresses technology used to enable users to exchange data between private and public networks. The Network Monitoring section considers ways to monitor the network infrastructure. The Network Scanners section has a slightly different focus, examining the system for vulnerabilities. Malicious code protection is covered along with multilevel security.

**UNCLASSIFIED**

Defend the Enclave Boundary/External Connections  
IATF Release 3.1—September 2002

**This page intentionally left blank.**

## 6.1 Firewalls

The purpose of a firewall is to protect internal information systems from external attacks. Firewalls address the requirement for authorized Local Area Network (LAN) users and administrators as well as individual workstation or personal-computer users, to safely access and be accessed-by untrusted (potentially hostile) external network connections. This means that all components inside the enclave boundary are protected against intrusion attacks: unauthorized extraction, modification, or deletion of data, denial-of-service, and theft of resources or services. This firewall section addresses all components used for protecting interconnected, digital-electronic processing, transmission, or storage of information.

The focus of this Firewall section is on external electronic intrusions through the enclave boundary into a LAN or workstation that may be possible due to electronic connections. Attacks such as those performed by insiders or passive intercepts of traffic traversing backbone networks are not directly addressed within this section of the Information Assurance Technical Framework (IATF). While the unique concerns of the other protection categories are primarily addressed elsewhere in the Framework, there are some fundamental protection countermeasures—common to most environments—addressed here. Clearly, the concerns and approaches relevant to external electronic intrusions are interdependent with those of other protection categories (such as remote access, system high interconnects, Multi-Level Security [MLS], or security for applications). Thus, the following firewall-focused sections are intended to be complementary and integrated rather than separate, distinct layers of protection. For further expansion of site security, refer to <http://www.ietf.org/rfc/rfc2196.txt?number=2196>, RFC 2196, Site Security Handbook.) [1]

### 6.1.1 Target Environment

Users within an enclave can access external information services via network connections, dedicated connections, or dial-up connections. The environment illustrated in Figure 6.1-1 includes various combinations of methods of access involving Internet Service Providers (ISP), Integrated Services Digital Networks (ISDN), Public Switched Telephone Networks (PSTN), X.25 Packet Exchange, wideband (cable-modems) and Internet and intranet networks/hosts that consist of both valid (trustworthy) agents and potentially hostile agents.

Included are those involving multiple access levels such as a private corporate LAN connecting to a public Wide Area Network (WAN), or a private corporate LAN connecting to a corporate intranet. The boundary protection approaches should be applied to many of the cases described in other categories (e.g., remote access, system high interconnections and virtual private networks [VPN]). Whenever networks (workstations) are interconnected, the Network Security Policy should require protection at the network access points; i.e., the enclave boundaries. Generally, the amount of protection needed increases as the sensitivity of the information increases, as differences in sensitivity levels increase, as the threat increases, and as the operational environment changes (likelihood for attack increases for high profile organizations).

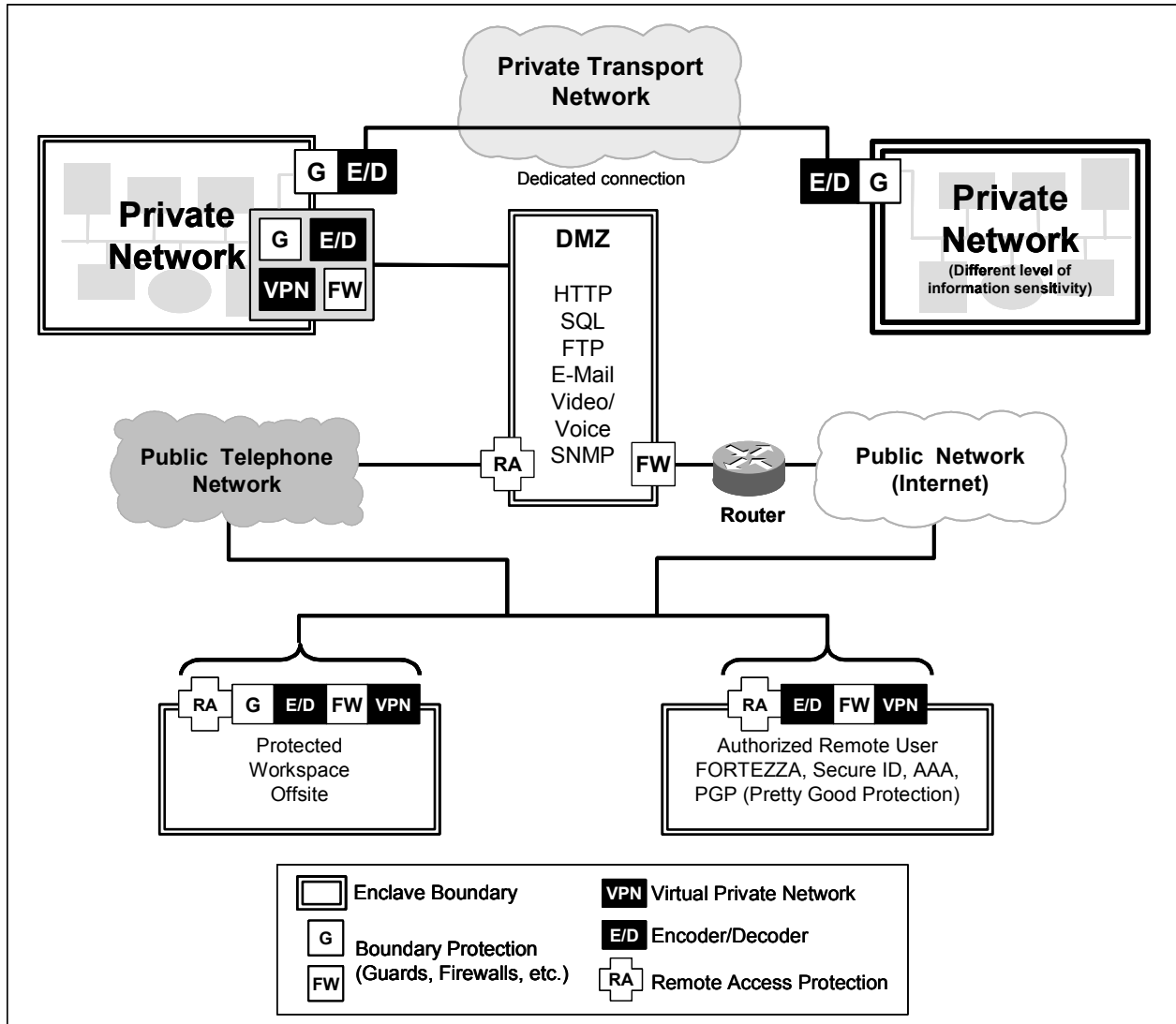

IATF\_6\_1\_1\_0101

Figure 6.1-1. Enclave Boundary Environment

## 6.1.2 Firewall Requirements

### 6.1.2.1 Functional Requirements

The following have been identified as representative ideal requirements based on a customer's perspective of needs:

- The user, if authorized, should have maximum access to needed information and services available on the WANs using any of the existing and emerging networking technologies and applications.

- The user and user's system should be protected against the full range of network attacks, be able to locate the source and type of intrusions, be able to react to such intrusions, and be able to fully reconstitute the system following damage caused by intrusions.
- The approaches used to protect network access points should have minimal operational impact on the user.
- The approaches used to protect network access points should have minimal operational impact on performance of the associated components and networks.
- The approaches used to protect network access points should be a scalable solution to allow for future needs.

## 6.1.2.2 Boundary Protection Mechanism Requirements

Boundary protection mechanisms are used to limit access to the internal network and are provided through the use of some combination of routers, firewalls, and guards. Refer to Section 6.1.4.1, Technical Countermeasures, Boundary Protection via Firewalls, for further expansion of this subject. The following are typical requirements that boundary protection mechanisms should offer.

- Restrict sources, destinations, and services and block dangerous protocols such as certain Internet Control Message Protocol (ICMP) messages. Both incoming and outgoing communications should be restricted.
- Restrict executable services and download capabilities.
- Employ internal Access Control Lists (ACL) where appropriate.
- Use Identification and Authentication (I&A) mechanisms—to include the use of software or hardware tokens—to authenticate outsiders to the boundary point.
- Use encryption to prevent interception of data that could provide the attacker with access to the network and for access control. This should include the encryption of remote management data.
- Hide the internal network (addresses, topology) from potential attackers using a mechanism such as network address translation.
- Log and analyze source-routed and other packets and react to or restrict attacks.
- Scan for malicious software.
- Facilitate proper boundary protection configuration by operators, e.g., user-friendly graphical user interface (GUI).
- Be self-monitoring and capable of generating alarms.



Note that the intent of several of these countermeasures is to eliminate vulnerabilities of services that may not be needed by a particular user system. Current technologies do not permit complete user access to all desired services and destinations while simultaneously blocking all attacks. In addition, the use of encryption and certain identification and authentication mechanisms (such as hardware tokens) limits interoperability. Trade-offs must be made.

### 6.1.2.3 Interoperability Requirements

The boundary protection should not force users to employ any nonstandard protocols or modes of operation nor any procedures that would prohibit interoperability with those external users or systems with which users desire to communicate and are permitted by the organization's network security policy.

- The firewall command and control channel must be secure to prevent eavesdroppers from learning the rules, Media Access Control (MAC) secrets, and other controlling data communicated over the firewall command and control channel (e.g., Simple Network Management Protocol (SNMP), Remote Monitor (RMON), Application Program Interface (API), and Telnet).
- An authentication mechanism is needed to prevent unauthorized entities from changing the rules. In the simplest case, IP-address-based authentication may be satisfactory. If end-devices are allowed to modify the rules (as they are with SOCKS), secure user-based authentication would have to be deployed along with an administration policy. For example, the policy may permit authenticated user A to open pinholes from his host at high port numbers and deny anything else. (SOCKS is out of the scope of this chapter; for more information refer to <http://www.socks.nec.com> and <ftp://ftp.nec.com/pub/socks>). [2, 3]

### 6.1.2.4 Anticipated Future Requirements

The approach employed to protect network access should allow for the evolution and reconfiguration of the network and associated components. The chosen approach should be scalable to allow for future evolutions.

## 6.1.3 Potential Attacks

As previously stated, the focus of this firewall section is on external attacks into a LAN or workstation that may be implemented by virtue of its electronic connections through the enclave boundary. The types of attacks are discussed below: active-based attacks, distribution attacks, and insider attacks. Other attack categories (passive attacks and close-in attacks) are not directly addressed within the remainder of this chapter, but relate to this category and the technologies discussed. Refer to Section 4.2, Adversaries, Threats (Motivations/Capabilities), and Attacks, and for additional details refer to Section 5.3, System-High Interconnections and VPNs, regarding virtual private networking capabilities regarding security and protecting enclave assets from attacks.

### 6.1.3.1 Active Attacks

Attacks at the network access points generally fall within the active attacks category as defined in Section 4.2.1.4, Categories of Attacks. This type of attack also has been referred to as an active attack. Any attempt to gain unauthorized access to a network or break network security features is an active attack. For more description, refer to Section 4.2.1.4.2, Table 4-2, Examples of Specific Active Attacks. Listed below are various examples of active attacks.

- Trick the Victim (Social Engineering).
- Masquerade as Authorized User/Server.
- Exploit System-Application and Operating System Software.
- Exploit Host or Network Trust.
- Exploit Data Execution.
- Exploit Protocols or Infrastructure Bugs.
- Denial of Service.

### 6.1.3.2 Distribution Attacks

Distribution attacks are the hostile modification of hardware or software. Such attacks can occur anytime hardware or software is transferred. For additional information, refer to Section 4.2.1.4.4, Hardware/Software Distribution Vulnerabilities and Attacks and Table 4-3, Examples of Specific Modification Attacks. The following are examples of distribution attacks.

- Via software distribution computer disks that are transferred among firewalls.
- Software that is downloaded from the Internet, e-mail, or an internal LAN system.
- Modifications made to hardware or software at the factory before distribution or during distribution. Malicious changes to software code or malicious modification of hardware can occur between the time it is produced in the factory and the time it is installed and used.
- During firewall configuration, especially from remote locations.

### 6.1.3.3 Insider Attacks

Although the emphasis of protecting network access points is on protecting the inside from a potentially hostile outside world, mechanisms are needed for protection against outside and inside intruders. Thus, some of the technologies identified in this section apply to both insider and outsider threats. Further, once an outsider has successfully attacked a system to obtain access, the outsider, in effect, maneuvers within the system as an insider would. Technologies such as those designed to detect attacks by an insider may be used in a similar manner to detect outsider attacks.

Insider attacks can occur when an authorized user (i.e., a person who has authorization to access the system) remotely connects to the system and unintentionally causes damage to the information or to the information processing system. This nonmalicious attack can occur either from the user not having the proper knowledge or by carelessness. Malicious insider attacks are those in which an authorized user causes damage to the system or enters areas where the user is not authorized. Malicious attacks can also be caused by an unauthorized individual employing an authorized user's personal computer (PC) to maneuver within the system and cause damage. An example would be when an authorized user's laptop computer is stolen and then used to gain access into the system. For more information, refer to Section 4.2.1.4.3, Insider Vulnerabilities and Attacks.

## **6.1.4 Potential Countermeasures**

Fundamentally, protecting network access points from potential attacks can be addressed by limiting access to and from the LAN or workstation. In the protection of a network, important issues that need to be addressed include detecting and identifying malicious or non-malicious insider attacks, identifying potential vulnerabilities, and attacks that may occur given the current configuration and responding to, deterring, and recovering from detected attacks. The following subsections describe security requirements applicable to addressing attacks through an enclave boundary. Several of the countermeasures are covered in detail within other IATF focus areas and are listed as applicable. The countermeasure requirements are grouped under the two primary headings of Technical Countermeasures and Administrative Countermeasures.

### **6.1.4.1 Technical Countermeasures**

#### **Boundary Protection via Firewalls**

Connecting through the enclave boundary to external resources such as the Internet introduces a number of security risks to an organization's information and resources. The first step in minimizing those risks consists of developing a comprehensive network security policy. This network security policy framework should include firewalls as boundary protection mechanisms. Boundary protection mechanisms can provide a measure of protection for a network or an individual workstation within the enclave boundary. The boundary protection device is intended to operate primarily as an access control device, limiting the traffic that can pass through the enclave boundary into the network. In general, boundary protection is provided through the use of some combination of routers, firewalls, and guards. Refer to Section 6.1.1.2, Firewall Requirements, Boundary Protection Mechanism Requirements for additional information.

Although the main focus of this section is firewalls, a definition of routers and guards follows. A router that is configured to act as a firewall is a packet-filtering device that operates at multiple layers and permits or denies traffic through the enclave boundary into the internal network based on a set of filters established by the administrator. A guard is generally a highly assured device that negotiates the transfer of data between enclaves operating at different security levels. Refer

to Section 6.3, Guards, for more information. In contrast, a firewall is a boundary protection device between networks communicating at the same security level.

A firewall is a collection of components placed between two networks (or an individual workstation and a network) with the following properties.

- All traffic from inside to outside and vice versa must pass through this mechanism.
- Only authorized traffic, as defined by the local network security policy, will be allowed to pass.
- The mechanism itself is immune to penetration.

Thus the firewall is a tool for enforcing the network security policy at the enclave boundary and has several distinct advantages as a protected network access device. First, the firewall allows for centralized network security management, as it becomes the focal point for network security decisions. In addition, as the only directly accessible component of the enclave network, the firewall limits the exposure of the network to attack. By implementing and following a well-defined network security policy, maintaining cognizance of current vulnerabilities, reviewing audit data, and using available scanning tools, the security of the enclave is greatly enhanced.

However, there are disadvantages to using firewalls. They can be the single points of attack to the enclave. Firewalls do not protect the network and workstations within the enclave against most data-driven attacks, some denial-of-service attacks, social engineering attacks, and malicious insiders. Firewalls can thus potentially provide a false sense of security. Firewalls must be looked at as being only one part of a larger network security approach.

## Access Constraint

Measures that should be taken to constrain access to facilitate defense of enclave boundaries include the following.

- Provide data separation. For data that is allowed access to the protected network or workstation, steps should be taken to constrain as much as possible the amount of the system that can be affected. Steps that could be taken include allowing executables to run only in a particular domain or only on a server reserved for such purposes as discussed in Section 6.3, Guards.
- Employ application-level access control. Access restrictions may also be implemented within the enclave—within workstations or at various points within a LAN—to provide additional layers and granularity of protection. See Access Control List under Section 6.3.5.3, Processing, Filtering, and Blocking Technologies.
- Provide authenticated access control and (as appropriate) encryption for network management. See a previous subheading in this category, Boundary Protection via Firewall and Section 6.3.5.1, Authenticated Parties Technologies.

## 6.1.4.2 Administrative Countermeasures

While defending the enclave boundary, administrative countermeasures should be implemented with the boundary protection mechanisms and throughout the enclave. Quality network management and network security administration are imperative in maximizing the security of the network's configuration and protection mechanisms and increasing the likelihood of detecting vulnerabilities and attacks. The following administrative mechanisms act as countermeasures to the various attacks mentioned in Section 6.1.3, Potential Attacks.

- Be prepared for severe denial-of-service attacks; i.e., institute and practice contingency plans for alternate services.
- Routinely inspect the firewall for physical penetrations.
- Educate users and staff on correct procedures when dealing with firewalls.
- Institute and exercise well-publicized firewall procedures for problem reporting and handling.
- Institute and exercise suspicious behavior-reporting channels.
- Institute and monitor critical access controls, e.g., restrict changeable passwords, require dial-back modems.
- Minimize use of the Internet for mission or time-critical connectivity.
- Require security-critical transactions to be conducted in-person; e.g., establishing identity when registering.
- Use trusted software where available and practical.
- Use subversion-constraining software and techniques wherever possible; e.g., avoid software that uses pointers that could be employed by a software developer to access unauthorized memory locations.
- Carefully map relationships between hosts and networks, constraining transitive trust wherever possible.
- Minimize cross-sharing between users and file systems, particularly for high-sensitivity or high-threat applications, allowing only essential functions that have compelling justifications for sharing.
- Where possible, do not rely on Domain Name Server (DNS) for security sensitive transactions where spoofing an Internet Protocol (IP) address could cause problems.
- Institute, exercise, and monitor a strict computer emergency response team alert and bulletin awareness and patch program.
- Institute and practice procedures for recovery from attack when the firewall is penetrated.

## Countermeasure Effectiveness

The following is a list of attacks and the most successful countermeasures against them. More detailed information about the types of attacks is also provided in Section 4.2, Adversaries, Threats (Motivations/Capabilities), and Attacks.

**Trick the Victim (Social Engineering).** The best defense against this type of attack is to educate system/network users. The users must be aware that attempts may be made to obtain their passwords to enable access to the network or to secure areas of the network that the attacker may not be authorized to access.

**Masquerade.** The best technical countermeasure against this type of defense is to identify and authenticate outsiders and to use access constraints to authenticate and encrypt data. Administrative countermeasures that have high levels of effectiveness include using and monitoring access controls and minimizing the use of the Internet for critical communications.

**Exploit Software Vulnerabilities.** The highest defenses against attacks made by exploiting vulnerabilities of software include subverting constrained software, monitoring the Computer Emergency Response Team (CERT), obtaining patches, and minimizing the use of the Internet for critical communications.

**Exploit Host or Network Trust.** Minimizing use of the Internet for critical communications and subverting constrained software provides the highest level of defense against attacks exploiting the host or trust in the network.

**Exploit via Executables.** Attacks against the enclave boundary through executable applications can be fought through technical and administrative countermeasures. Overall technical measures that can be implemented include boundary protection, access constraints, and detection mechanisms. Boundary protection offers the best technical defense by restricting sources and services, by restricting the ability to download, and by restricting executables. Administrative measures to counteract attacks via executables are minimizing the use of the Internet for critical communications and using subversion-constraining software.

**Exploit Protocol Bugs.** To protect against protocol bugs, the two countermeasures providing the best defense are—once again—minimizing the use of the Internet for critical communications and using subversion-constraining software.

**Denial of Service.** The best technical defense for a denial-of-service attack against a system is to have a detection and response system in place. Administrative countermeasures include advance planning to be able to offer service alternatives, minimize Internet usage for critical communications, and to have documented and rehearsed recovery procedures in place to help reconstitute the system.

## 6.1.5 Firewall Technology Assessment

### Access Control/Filtering

Access control/filtering is the main function of every firewall. This function can be accomplished in several ways ranging from a proxy at the application layer of the Open Systems Interconnection (OSI) model to stateful inspection at the IP layer. By its nature, the firewall implements a specific network security policy that corresponds to the level of sensitivity of the boundary the firewall is protecting. The main fundamental purpose of the security policy is to limit access to the network and systems inside the enclave boundary from external sources. Only necessary in-bound connections and services should be allowed. The firewall also restricts the connectivity of internal users to external destinations. Although internal users are generally trusted, they should be limited in what services they can use through the firewall to prevent them from unintentionally opening security vulnerabilities. The different firewall technologies offer different granularities of access control. Some firewalls are now capable of what were traditionally guard-like filtering functions. For example, firewalls incorporate software that filters access to either specific Universal Resource Locators (URL) or categories of URLs. Certain File Transfer Protocol (FTP) commands can be blocked while other commands are allowed through the firewall. Technology will continue to develop in this area. Very sophisticated and highly refined access control capabilities are likely to become standard firewall features.

### Identification and Authentication

Identification and authentication is one of the major functions provided by the different firewall products. While users on the inside of a firewall, inside the enclave boundary, are often considered trusted, external users who require access to the internal network must be authenticated. Most security experts agree that passwords are not a strong method of authentication. In fact, cracking user passwords is one of the most common system attacks. Other authentication methods for screening access through a firewall include one-time passwords, time-based passwords, and challenge-response schemes. The most common one-time password system in use is S\key, a software-based authentication mechanism using Message Digest 4 (MD4) or Message Digest 5 (MD5). S\key works by starting with a seed and applying MD4 or MD5 to generate a sequence of keys. S\key encodes the keys into a series of short words and prompts the user for the previous key, n-1, then S\key applies the MD4 or MD5 to the user's answer and checks to see if the result is the key n that it knows. Time-based passwords are a special form of one-time password. In these systems, the password varies at a specified time interval based on an internal algorithm, thus adding the additional complication of maintaining clock synchronization. Challenge-response systems are more complex and involve something the user has (a smart card or PC card) and something the user knows (password). Although it is possible to implement these systems in software, using hardware tokens has numerous advantages. Commercial firewall products support a wide range of authentication mechanisms.

## Mobile Code Blocking

In addition to more basic blocks of mobile code (Java, \*Script, ActiveX, etc.), firewall systems are beginning to offer containment for the execution of mobile code. This includes sandbox machines isolated from the rest of the network and restricted environments to run the Java Virtual Machine (VM) within. Refer to RFC 1918—Address Allocation for Private Internets for more information: <http://www.ietf.org/rfc/rfc1918.txt?number=1918>. [4]

## Encryption

Firewalls become a focal point for the enforcement of security policy. Some firewalls take advantage of this to provide additional security services, including traffic encryption and decryption. To communicate in encryption mode, the sending and receiving firewalls must use compatible encrypting systems. Current standards efforts in encryption and key management have begun to allow different manufacturers' firewalls to communicate securely. To address this situation, vendors have been working on a network-level encryption interoperability approach through the Internet Protocol Security (IPSec) standard, set forth by the Internet Engineering Task Force (IETF). However, these efforts require further development before the customer can assume compatibility. Firewall-to-firewall encryption is thus used for secure communication over the Internet between known entities with prior arrangement, rather than for any-to-any connections. Verifying the authenticity of system users is another important part of network security. Firewalls can perform sophisticated authentication, using smart cards, tokens, and other methods.

## Auditing

Auditing refers to the tracking of activity by users and administrators. As opposed to accounting—where the purpose is to track consumption of resources—the purpose of auditing is to determine the nature of a user's network activity. Examples of auditing information include the identity of the user, the nature of the services used, when hosts were accessed, protocols used, and others.

## Network Address Translation

Network Address Translation (NAT) is a method by which IP addresses are mapped from one realm to another to provide transparent routing to hosts. NAT enables a LAN to use one set of IP addresses for internal traffic and a second set of addresses for external traffic. Traditionally, NAT devices are used to connect an isolated address realm with private unregistered addresses to an external realm with globally unique registered addresses (Internet). That is, a NAT device sits at the enclave boundary between the LAN and the Internet and makes all necessary IP address translations.



## Resist Penetration

Another important aspect of a firewall is how well it protects itself against attack. The firewall itself should resist penetration, because breaking into the firewall will give a hacker access to the entire network. Most firewalls run on stripped-down versions of the operating system; unnecessary executables, compilers, and other dangerous files are removed. In addition, some firewalls employ technology that makes penetrating the firewall operating system extremely difficult. These firewalls are built on trusted operating systems or use mechanisms such as type enforcement (i.e., controls based on factors that can only be changed by the system security administrator) to provide this extra protection against penetration. Although these types of additional safeguards are traditionally found on guard devices, firewalls are also beginning to offer this type of extra protection against enclave boundary penetration.

## Configuration and Third Party Monitoring

Properly configuring the firewall components is critical to the security of the enclave boundary. Most vulnerabilities in firewalls arise from the improper configuration or maintenance of the firewall. For this reason, it is important to examine the administrative interface provided by the firewall. A GUI alone will not make the firewall any more secure. However, a well-designed operator interface can ease the administrative burden and more effectively illustrate how well the firewall has implemented the security policy. Firewalls also make use of various self-monitoring tools. These tools can provide additional access controls, can increase the auditing capability of the firewall, and can provide for an integrity check on the file system of the firewall. Some of these tools are proprietary and are provided with the firewall; other tools are available from the third parties and can be used to enhance the security of the firewall.

### 6.1.5.1 Firewall Types

#### Packet Filtering

Because routers are commonly deployed where networks with differing security requirements and policy meet, it makes sense to employ packet filtering on routers to allow only authorized network traffic, to the extent possible. The use of packet filtering in those routers can be a cost-effective mechanism to add firewall capability to an existing routing infrastructure.

As the name implies, packet filters select packets to filter (discard) during the routing process. These filtering decisions are usually based on comparing the contents of the individual packet headers (e.g., source address, destination address, protocol, and port) against preset rule sets. Some packet filter implementations offer filtering capabilities based on other information beyond the header. These are discussed below in Stateful Pack Filtering. Packet filtering routers offer the highest performance firewall mechanism. However, they are harder to configure because they are configured at a lower level, requiring a detailed understanding of protocols.

## Stateful Packet Filtering

Stateful packet filtering technology, also referred to as *stateful inspection*, provides an enhanced level of network security compared to the static packet filtering described above. The stateful packet filter—working at layer 3 of the OSI model to examine the state of active network connections—looks at the same header information as packet filters do, but can also look into the data of the packet where the application protocol appears. Based on the information gathered, stateful packet filtering determines what packets to accept or reject. More importantly this technology allows the firewall to dynamically maintain state and context information about *previous* packets. Thus, the stateful packet filter compares the first packet in a connection to the rule set. If the first packet is permitted through, the stateful packet filter adds the information to an internal database called a state table. This stored information allows subsequent packets in that connection to pass quickly through the firewall.

Network security decisions can then be based on this state information. For example, the firewall can respond to an FTP port command by dynamically allowing a connection back to a particular port. Because they have the capability of retaining state information, stateful packet filters permit User Datagram Protocol (UDP)-based services (not commonly supported by firewalls) to pass through the firewall. Thus stateful packet filters are advertised to offer greater flexibility and scalability. Stateful packet filtering technology also allows for logging and auditing and can provide strong authentication for certain services. Logging, or authentication as required by the rule set, occurs at the application layer (OSI layer 7). A typical stateful packet filtering firewall -may log only the source and destination IP addresses and ports, similar to logging with a router.

Unlike application-level gateways, stateful inspection uses business rules defined by the administrator and therefore does not rely on predefined application information. Stateful inspection also takes less processing power than application-level analysis. However, stateful inspection firewalls do not recognize specific applications and thus are unable to apply different rules to different applications.

## Proxy Service, Application Gateways and Circuit Gateways

Figure 6.1-2, shows how proxy services prevent traffic from directly passing between networks. Rather, Proxy Services are software applications that allow for connections of only those application sessions (e.g., Telnet, FTP, DNS, Simple Mail Transfer Protocol (SMTP) for which there is a proxy. Thus, proxy services are application-level firewalls. The host running the proxy service is referred to as an application gateway. Since an application-level gateway is a system set up specifically to counter attacks from the external network, it is also referred to as a bastion host. If the application gateway contains proxies for only Telnet or DNS, only these sessions will be allowed into the subnetwork. If a proxy does not exist on the application gateway for a particular session (Telnet, DNS, FTP, SMTP), those sessions will be completely blocked. Therefore, only essential services should be installed on the bastion host, for if a service is not installed, it cannot be attacked. Proxy services can also filter connections through the enclave boundary by denying the use of particular commands within the protocol session

(e.g., the FTP put command) and by determining which internal hosts can be accessed by that service.

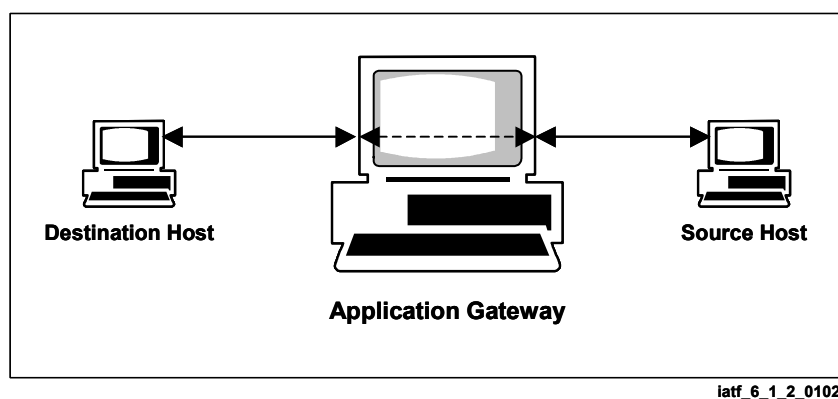

**Figure 6.1-2. Application Gateway**

By using an application gateway through which access to the subnetwork is permitted, internal information can be hidden from systems outside the enclave boundary. The application gateway can provide a means for strong authentication by requiring additional authentication such as an additional password or the use of a smart card. Each proxy contained within the bastion host can also be set up to require yet another password before permitting access. The bastion host and each proxy service can maintain detailed information by logging all traffic and the details of the connections. Logging helps in the discovery of, and response to, attacks. Each proxy is independent of all other proxies that may be running on the bastion host, so any operational malfunction of one proxy will not affect the operation of the other proxies. This also allows for ease of installation and removal of proxies from the system.

Circuit-level gateways are another type of firewall. A circuit-level gateway relays Transmission Control Protocol (TCP) connections without performing any additional packet processing or filtering. Circuit-level gateways are often used for outgoing connections where internal users are trusted. Outbound connections are passed through the enclave boundary based on policy and inbound connections are blocked. Permission is granted by port address, upon which management control is primarily based. Although a circuit-level gateway is a function that can be performed by an application-level gateway, it is not as secure as an application-level gateway. When completing a connection, checking is not conducted to verify if application protocols (proxies) exist on the application gateway. Therefore, a circuit relay will not detect the violation if approved port numbers are used to run unapproved applications. A circuit-level proxy, acting as a wire, can be used across several application protocols. A bastion host can be configured as a hybrid gateway supporting application-level or proxy services for in-bound connections and circuit-level functions for outbound connections. Circuit-level firewalls are less common than application-level firewalls due to the high probability that client modifications will be necessary to allow use of the circuit-level protocol.

Application gateways are generally dual-homed, which means that they are connected to both the protected network and the public network; however, they can be used in other configurations as discussed below. Packet filtering firewalls can also be dual-homed.

## 6.1.5.2 Firewall Architectures

### Dual-Homed

A dual-homed gateway architecture has two network interfaces, one on each network, and blocks all traffic passing through it, as shown in Figure 6.1-3. That is, the host cannot directly forward traffic between the two interfaces. Bypassing the proxy services is not allowed. The physical topology forces all traffic destined for the private network through the bastion host and provides additional security when outside users are granted direct access to the information server.

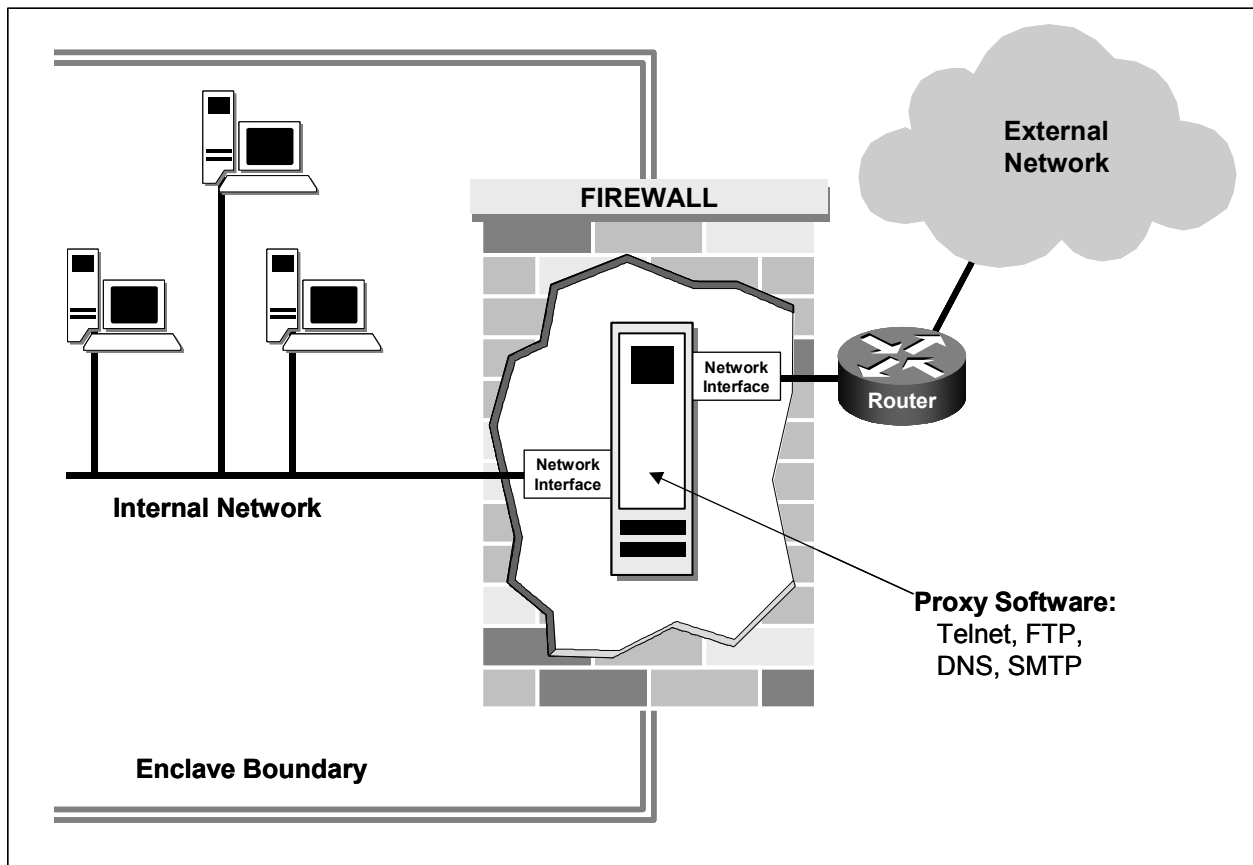

latf\_6.1\_3\_0103

Figure 6.1-3. Dual-Homed Firewall Architecture

### Screened Host (Hybrid)

A screened host is a type of firewall that implements both network-layer and application-layer security by using both a packet-filtering router and a bastion host. A screened host architecture is also known as a hybrid architecture. This type of firewall architecture provides a higher level of network security, requiring an attacker to penetrate two separate systems. The system is set up with a packet filtering router sitting between an untrusted (external) network and the bastion host on the protected network so that only allowable traffic from untrusted networks pass to or

from the internal bastion host. (See Figure 6.1-4.) The packet filtering router is configured in such a manner that outside traffic has access only to the bastion host. An additional router may be set up between the Bastion Host and the internal network for a greater level of security.

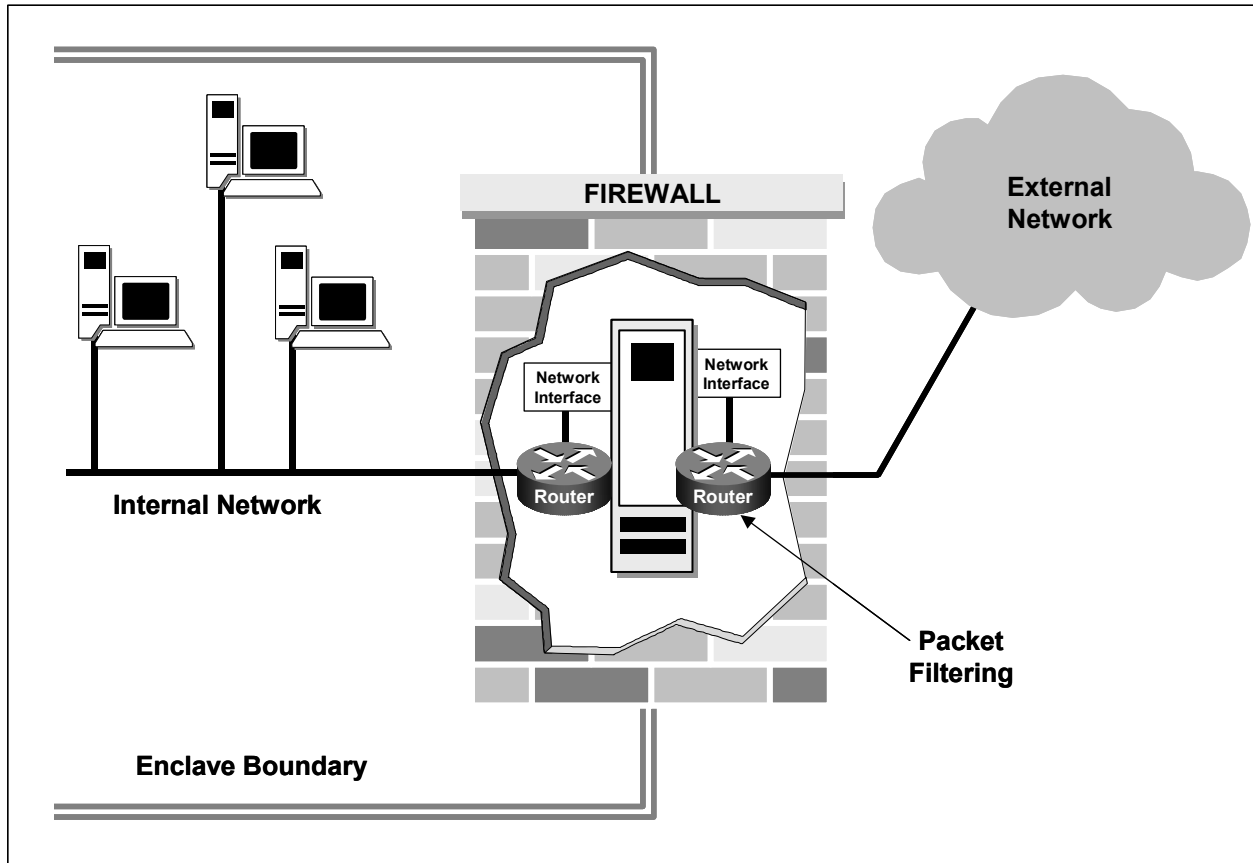

iatf\_6\_1\_4\_0104

Figure 6.1-4. Screened Host Firewall Architecture

## Screened Subnet

In the Screened Subnet firewall architecture, see Figure 6.1-5, a host is set up as a gateway with three NIC's, one connected to the external network through a router, one to the internal network, and one to the Demilitarized Zone (DMZ). Packet forwarding is disabled on the gateway and information is passed at the application level or the network layer depending on the type of firewall used. The gateway can be reached from all sides, but traffic cannot directly flow across it unless that particular traffic is allowed to pass to the destination it is requesting.

The router should also be setup with ACLs or IP filtering so connections are allowed between the router and the firewall only. The screened subnet provides external, untrusted networks restricted access to the DMZ for services such as World Wide Web (WWW) or (FTP). It allows the enclave to place its public servers in a secure network that requires external sources to traverse the firewall and its security policy to access the public servers, but will not compromise the operating environment of the internal networks if one of the networks is attacked by hackers.

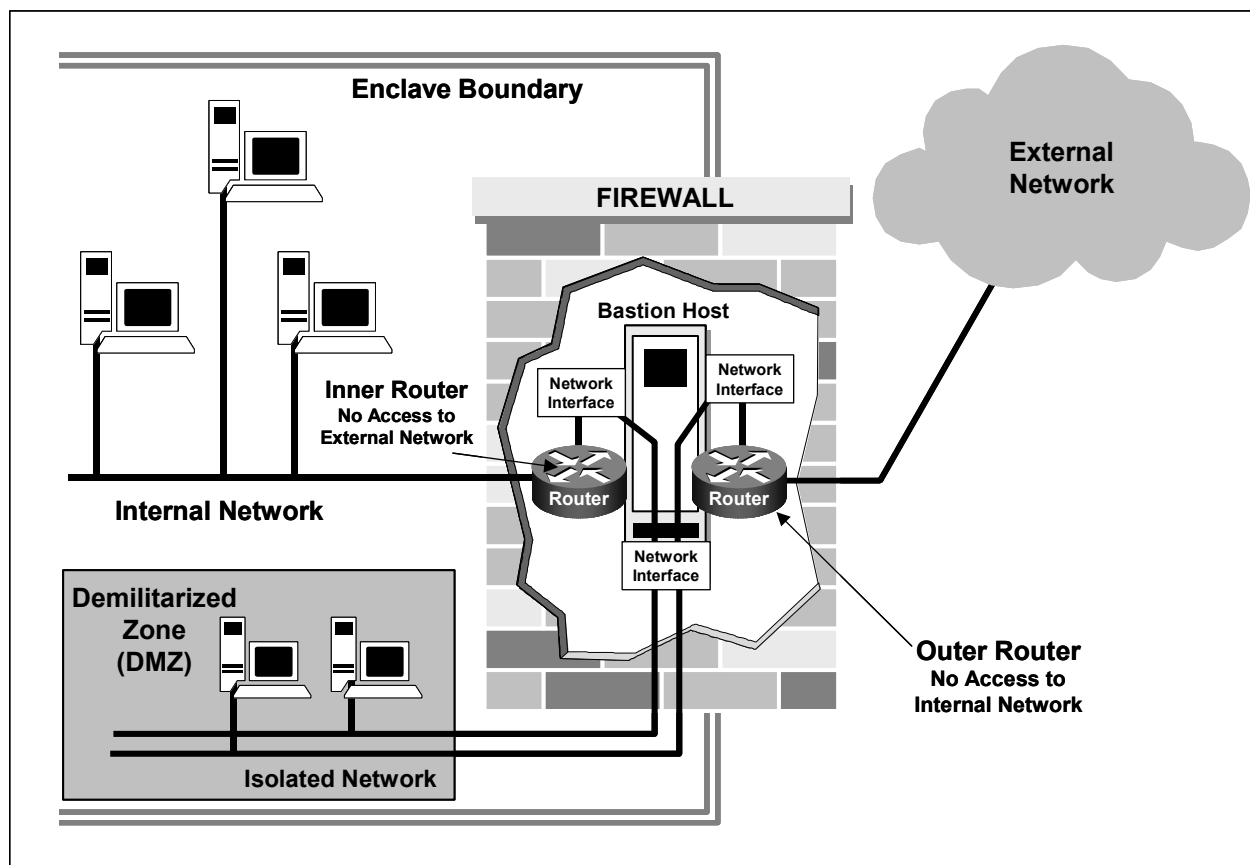

iatf\_6\_1\_5\_0105

**Figure 6.1-5. Screened Subnet Firewall Architecture**

The screened subnet firewall may be more appropriate for sites with large traffic volume or high-speed traffic. A screened subnet can be made more flexible by permitting certain trusted services to pass from the external network to the protected network, but this may weaken the firewall by allowing exceptions. Greater throughput can be achieved when a router is used as the gateway to the protected subnet. Because routers can direct traffic to specific systems, the application gateway does not necessarily need to be dual-homed. However, a dual-homed gateway is less susceptible to weakening. With a dual-homed gateway, services cannot be passed for which there is no proxy. The screened subnet firewall could also be used to provide a location to house systems that need direct access to services.

### 6.1.5.3 Firewall Selection Criteria

When selecting a firewall system the following should be considered.

- The firewall should be able to support a “deny all services except those specifically permitted” design policy, even if that is not the policy used.
- The firewall should support your network security policy, not impose one.

## UNCLASSIFIED

### Firewalls

IATF Release 3.1—September 2002

- The firewall should be flexible; it should be able to accommodate new services and needs if the network security policy of the organization changes.
- The firewall should contain advanced authentication measures or should contain the hooks for installing advanced authentication measures.
- The firewall should employ filtering techniques to permit or deny services to specified host systems as needed.
- The IP filtering language should be flexible, user-friendly to program, and should filter on as many attributes as possible, including source and destination IP address, protocol type, source and destination TCP/UDP port, and inbound and outbound interface.
- The firewall should use proxy services for services such as FTP and Telnet, so that advanced authentication measures can be employed and centralized at the firewall. If services such as Network News Transfer Protocol (NNTP), X Window System (X), Hypertext Transfer Protocol (HTTP), or gopher are required, the firewall should contain the corresponding proxy services.
- The firewall should have the ability to centralize SMTP access to reduce direct SMTP connections between site and remote systems. This results in centralized handling of site e-mail.
- The firewall should accommodate public access to the site in such a way that public information servers can be protected by the firewall, but can be segregated from site systems that do not require public access.
- The firewall should have the ability to concentrate and filter dial-in access.
- The firewall should have mechanisms for logging traffic and suspicious activity and should contain mechanisms for log reduction to ensure logs are readable and understandable.
- If the firewall requires an operating system such as UNIX, a secured version of the operating system should be part of the firewall, with other network security tools as necessary to ensure firewall host integrity. The operating system at start up should have all current and approved patches installed.
- The firewall should be designed and implemented in such a manner that its strength and correctness is verifiable. It should be simple in design so it can be understood and maintained.
- The firewall, and any corresponding operating system, should be maintained with current and approved patches and other bug fixes in a timely manner.

## 6.1.6 Cases

### Case 1

*A user communicating from a protected network to a public network. The information that is being sent is unclassified but private.*

This is a case of the typical user connecting and passing information across the Internet. In Figure 6.1-6, a workstation within the protected network is communicating with the Internet. When connecting to a network of a lower protection level, mechanisms should be in place at the enclave boundary to provide protection for the users' workstation and the protected network.

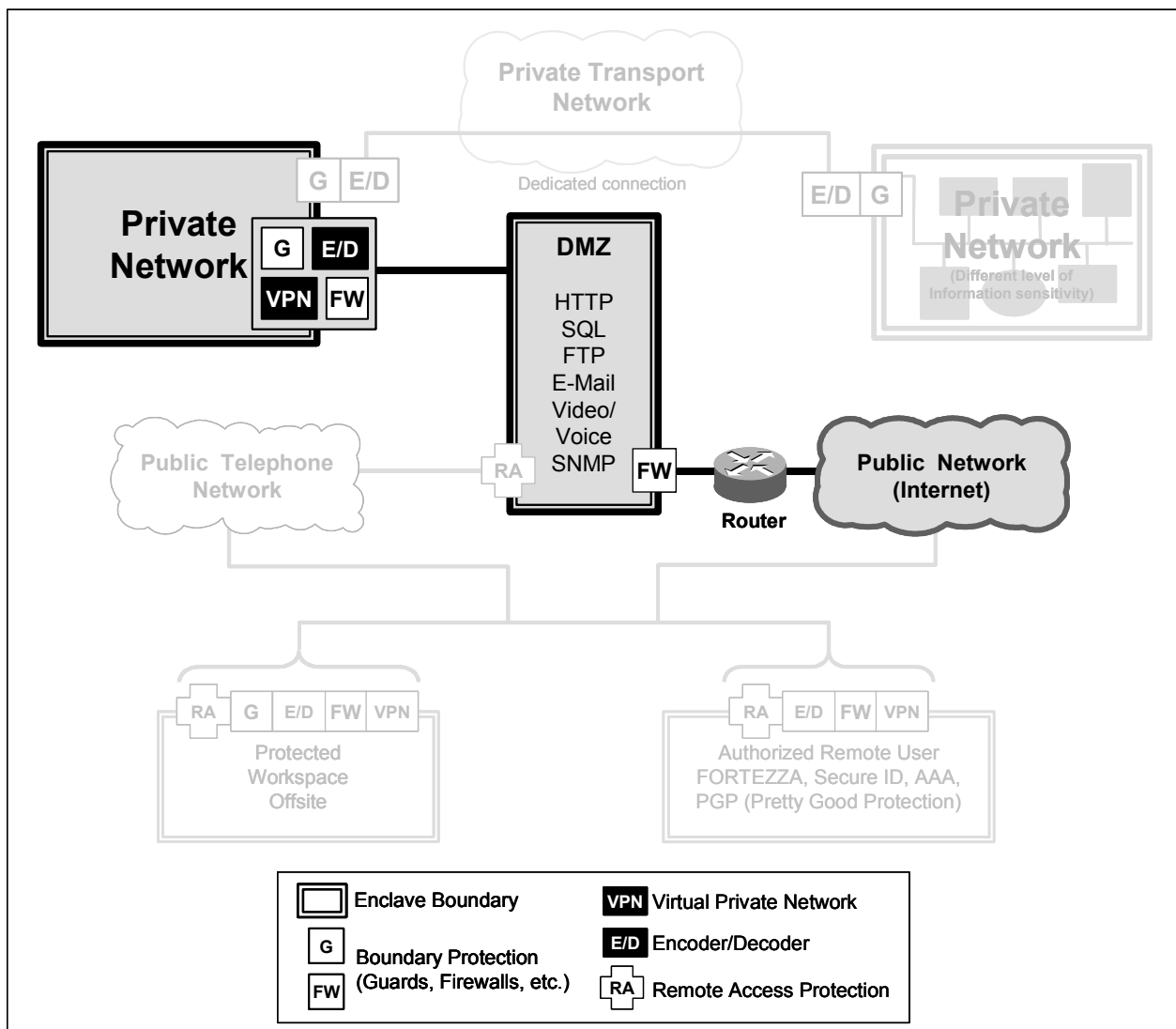

iatf\_6\_1\_6\_0106

Figure 6.1-6. Case 1—Private to Public Network Communication



## UNCLASSIFIED

Firewalls

IATF Release 3.1—September 2002

A firewall can be deployed as part of an effective boundary protection function. Other components of boundary protection that can be implemented are through e-mail, browsers, operating system configuration; and router configuration. Once mechanisms are in place to protect the enclave boundary, vulnerability checking and scanning procedures need to be implemented and exercised on the network and on the firewall.

As part of the boundary protection plan a site survey should be performed to ensure that the network operations and configuration is well understood. To assist with the site survey, a mapping tool can be used to construct the networks' topology and to examine the physical security of the network. The network map should detail which systems connect to public networks, and which addresses occur on each subnetwork. The network map should also identify which systems need to be protected from public access and identify which servers need to be visible on the outside and perimeter networks and what type of authentication and authorization is required before users can access the servers. The site survey should also examine which applications are used by authorized users of the network, what the anticipated growth of the network is, and what a users' privileges are including system administrators and firewall administrators. In general, the site survey that should be attempted is directly related to the following.

- Technical expertise of the individual conducting the scanning.
- Level of threat.
- Sensitivity of potentially vulnerable information.
- Integrity of the source of the scanning software.

The placement of the firewall is of critical importance to the security of the network. The network needs to be configured to ensure that if an intruder accesses one part of the system, the intruder does not automatically have access to the rest of the system. A firewall should be placed at egress points to the network.

The recommended procedures that should be implemented relative to the firewall for protecting the enclave boundary include:

- Ensure that the virus-scanning application is no more than a few weeks old. Viruses may infect the firewall itself as well as resources behind the firewall.
- Ensure that passwords and logins are not in clear text. Clear text passwords and logins are unencrypted and unscrambled and therefore vulnerable to sniffers on the Internet, allowing hackers to obtain passwords.
- Ensure that passwords and Secure Sockets Layers (SSL) are not cached by proxy agents on the firewall.
- Train personnel on firewall operations and administration.
- Audit for intrusive or anomalous behavior employing operating system, browser, and e-mail built-in audit capabilities.

- Routers can be configured as a firewall and for port mappings. With routers, anti-spoofing can be implemented, especially at the enclave boundaries or between domains of network administration. Source address spoofing and denial-of-service protection can also be provided with access lists. The goal of creating an access list at the firewall level to prevent spoofing is to deny traffic that arrives on interfaces on nonviable paths from the supposed source address. For example, if traffic arrives on an interface sitting on the corporate side, yet the source address states that the traffic originated from the Internet, the traffic should be denied, as the source address has been falsified, or “spoofed.” Antispoofing access lists should always reject broadcast or multicast traffic.
- Routers could also be configured to hide the real network identity of internal systems from the outside network through port address translation. Port address translation minimizes the number of globally valid IP addresses required to support private or invalid internal addressing schemes.
- Configure operating system, browser, and applications for firewall functions and to permit specific access (make use of a proxy-based/application gateway). All traffic passing through the firewall should be proxied and/or filtered by the firewall. Proxies reduce the probability that flaws in the service can be exploited. Filtering limits the services that can be used and the user communities that have permission to use a service. The fewer services allowed through the firewall, the fewer opportunities there are to attack the protected network/system.
- Develop and exercise plans to handle any security incidents that may occur. These plans need to cover such things as:
  - How to handle detected port scans or more malicious attacks.
  - Recovery from any incident that degrades the performance of the network.
  - The procedure for adding new services to the firewall.

## Case 2

*A privileged user remotely connecting to a private network from dedicated workstations situated within a DMZ of a different protected network.*

This case is an example of remotely accessing a company’s network from an off-site location. This off-site location is a protected network and has dedicated workstations connecting through that corporation’s DMZ. Multiple connections through the DMZ can be established. Figure 6.1-7 illustrates a valid remote user connecting through the DMZ to the protected network. A DMZ allows authenticated authorized users to tunnel through the firewall. A DMZ also allows access to a Web or FTP server inside the firewall without exposing the rest of the network to unauthorized users. Otherwise, intruders could gain control over the FTP or Web server and attack other hosts in the network. Therefore, servers should be placed so they can be accessed from any address in a separate subnetwork. Organizations can design, deploy, and proactively update and monitor a multi-zoned security network through a single firewall strategy. Administrators can create multiple DMZs within the network by simply adding rules to the existing firewall.

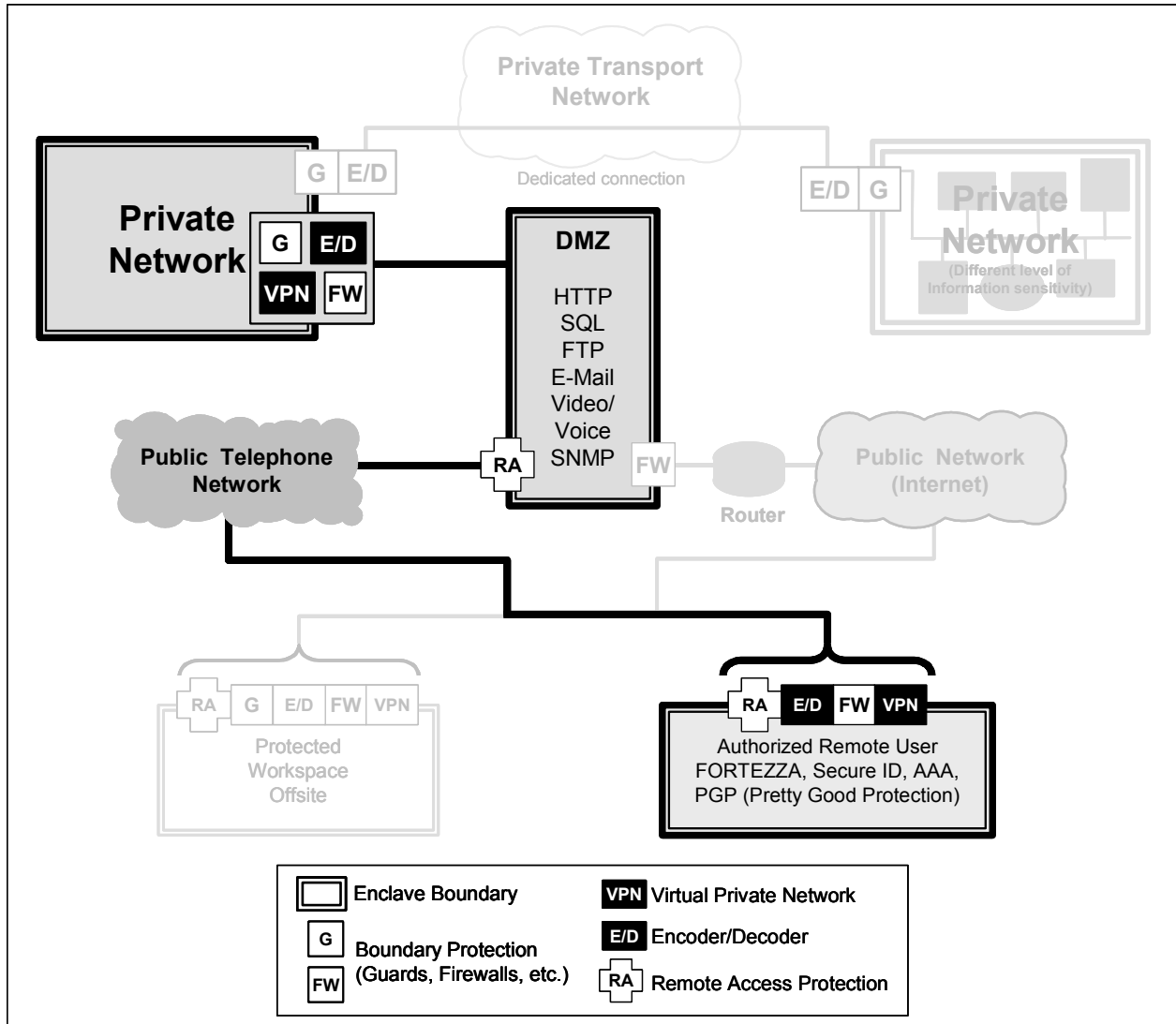

latf\_6\_1\_7\_0107

**Figure 6.1-7. Case 2—Remotely Accessing a Private Network**

Modem banks should be established as part of the firewall protection approach so that users can dial out and remote users can dial in via a modem bank. Modems should not be allowed on networked computers within the protected enclave boundary. By bypassing the implemented firewall and using a modem to connect to the Internet, all control over network security is lost. By using modem pools (a single dial-in point), all users are authenticated in the same manner. In addition, anti-spoofing controls can be applied at dial-up pools and other end-use connection points (also refer to <http://www.ietf.org/rfc/rfc2267.txt?number=2267>, RFC 2267). [5]

Before a user can access anything on the network, a username and password check should be completed. A stringent password policy is beneficial. One-time password schemes can also be used to further enhance the password security policy when establishing remote connections.

Remote access connections use standard authentication techniques (refer to Section 6.1.5, Firewall Technology Assessment, for more information regarding authentication).

Authentication, Authorization, and Accounting (AAA) for network access provides an additional level of security. AAA is the act of verifying a claimed identity, determining if the user has permission to access the requested resource, and collecting resource usage information for analyzing trends, auditing, billing or allocating costs. Message authentication plays a role when handling encrypted information. This verifies that the purported message sender is the person who really sent the message and that the message contents have not been altered. Although data can be authenticated at any hop on the way to the end destination, only the final destination may decrypt the data.

Refer to [www.ietf.org/rfc/rfc2989.txt](http://www.ietf.org/rfc/rfc2989.txt). [6] When remotely connecting to a company system, an alternative that also provides security is to establish a VPN. (See Section 5.3, System High Interconnections and Virtual Private Networks.)

Encryption of data is another common security measure. Encryption may be co-located with the firewall to provide secure tunnels to remote authorized users. Encoder/decoder products can be hardware- or software-based. Hardware-based solutions include PC cards (i.e., FORTEZZA), smart cards, or separate boxes attached to a network (for example, TACLANE, FASTLANE). For more information about FORTEZZA®, refer to <http://www.fortezza-support.com>. [7] There are also encryption software packages for encrypting e-mail such as Pretty Good Privacy (available free on the Internet, the site address is <http://www.wtvi.com/teks/pgp/>). [8] Software-based encoders/decoders also offer the capability of remote authentication, remote control, auto-answer secure data, and operation in both attended and unattended environments, therefore providing protection for facsimiles, e-mail, and computer communications. For further information on the FASTLANE and TACLANE refer to the FASTLANE category under Products & Services on General Dynamics' Web page, [www.gd-cs.com](http://www.gd-cs.com). [9]

Users can also connect to their company's intranet via the Internet from a remote location. If a company's intranet is not configured properly, with some modification to the Internet site's URL, a hacker can gain access to the private intranet site. When setting up an intranet, access should be restricted to internally managed IP addresses only. Subnetting and access lists should also be implemented to allow only those permissible users within a company access to the Internet or certain intranet sites. Also, when establishing a virtual web or naming Web pages, make the names cryptic so the content is not obvious and make all pages that contain private information password protected. This will prevent unauthorized people—from outside and inside the organization—from gaining unauthorized access to information.

### Case 3

*Sensitive private network containing valuable information communicated through a lower level network to another network of equal classification/value (system high interconnects).*

This case involves networks that are interconnected at essentially the same information sensitivity level, using a lower sensitivity level unprotected, public transmission media (Internet,

wireless). Referring to Figure 6.1-8, this scenario begins with the protected network containing proprietary data connecting via a public network to remote protected workspaces or valid remote users. At a minimum, this case requires:

- A boundary protection device (Firewall).
- A secure data connection device, i.e., encoder/decoder (KG, FASTLANE, TACLANE, FORTEZZA or other commercial-off-the-shelf [COTS]/government-off-the-shelf [GOTS]).
- A proactive audit capability to include COTS/GOTS intrusion detection products.

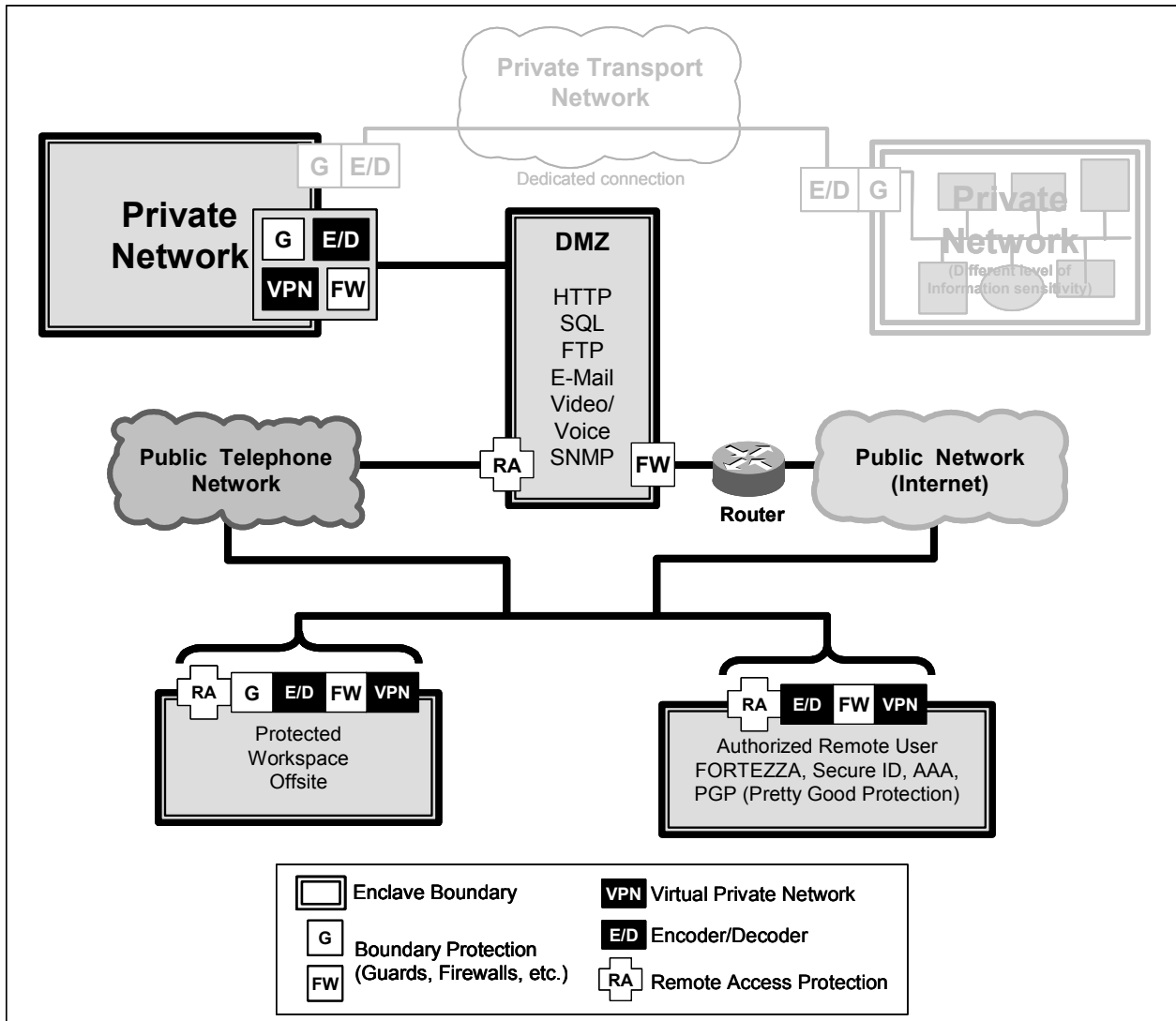

iatf\_6\_1\_8\_0108

Figure 6.1-8. Case 3—Private Network Connectivity via a Lower-Level Network

Medium assurance levels are required for the enclave boundary protection implementations. For this case, the recommended boundary protection procedures that should be implemented in priority order are:

- Institutionalize border security awareness and procedures as outlined in Chapters 3 and 4.
- Configure the local computing environment (home network) with built-in features and services for enclave boundary protection. Installation of firewall and/or comparable firewall feature set technology.
- Enable available audit capabilities to include firewall ingress and egress points and auditing of attempted resource connections.
- Scan for viruses using current virus definitions and profiles. Ensure that definition file databases are no more than a couple of weeks old.
- Perform a non-hostile vulnerability scan. Non-hostile scans include scans of: HTTP, FTP, Post Office Protocol (POP), SMTP, SNMP, ICMP, Telnet, Netbios, ensuring no deviations from initial network baseline scan.
- Perform comprehensive vulnerability scans to include: scans for non-standard UDP/TCP ports, unauthorized protocols, shares, unencrypted passwords, potential operating system related vulnerabilities.
- Add intrusion detection. Intrusion detection methods should include the ability to proactively monitor packets, log and alert appropriate personnel based on level of threat/probe, identify and record addresses of threat initiator(s).
- Couple scanning, monitoring, and testing with intrusion detection. A network is only as strong as its weakest link. By coupling scanning, monitoring, and testing—with intrusion detection—weaknesses and potential threats can be proactively identified upon first appearance or during the manifestation stage.

In addition, it is recommended that at least one staff person with an understanding of boundary protection be employed to configure and monitor the security parameters, perform virus and vulnerability scanning, and continually update the boundary protection and other security measures as vulnerabilities are detected and new intrusion detection capabilities become available.

Software associated with the operating system, firewalls, and routers should be updated as the software continues to evolve with respect to built-in security features, especially as they relate to authentication and intrusion detection.

## Case 4

*Collaborating organizational LAN connecting to the main backbone network of the same classification, with public WAN connections to remote protected networks; e.g., North Atlantic*

*Treaty Organization (NATO) or foreign trusted network connected to main backbone network which is also connected to remote protected LAN(s) via a public WAN (Internet).*

This case involves connections that may jeopardize interconnected high-level systems if users and administrators are not aware of the public-level WAN connection. As Figure 6.1-9 depicts, the unprotected network with proprietary data connects across a dedicated connection to the protected network with proprietary data, which is also connected to the public network/Internet and to remote users. The most basic level of protection for an enclave boundary includes employing the best available boundary protection technology (e.g., high assurance guards and intrusion detectors). Frequent virus and vulnerability scanning should also be performed by highly skilled personnel. An extensive security awareness program with institutionalized procedures for reporting and tracking is mandatory.

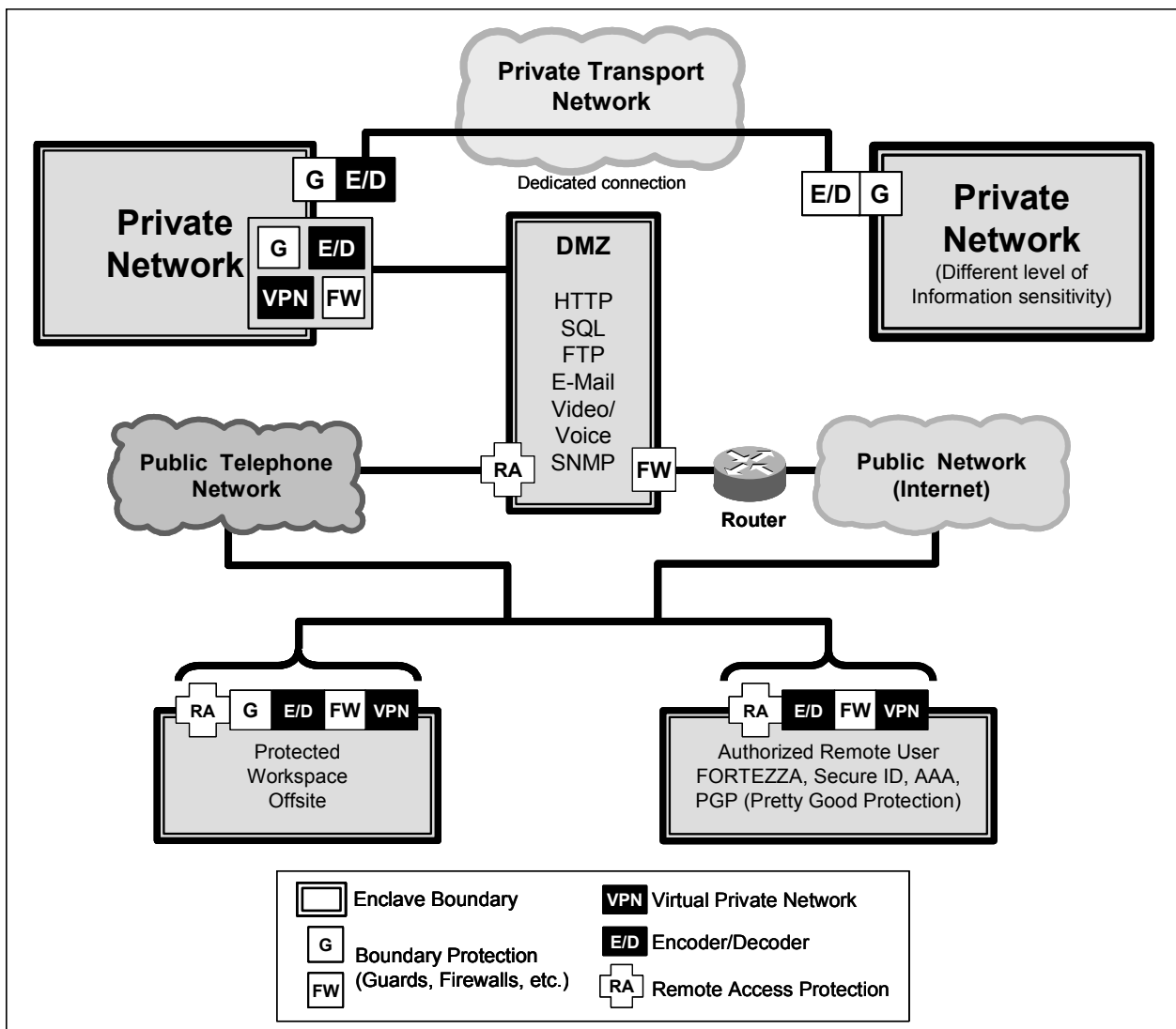

latf\_6\_1\_9\_0109

Figure 6.1-9. Case 4—Collaborative LAN's with Public Network Connections

The following scenarios require comprehensive protection from enclave boundary or network access point penetrations, employing the best available technology.

*Collaborating LAN connecting to main LAN via dedicated connection.*

The collaborating LAN (foreign company, NATO agency, etc.) is of the same information sensitivity level, and the anticipated threat level is at a minimum. Because the collaborating agency is accessing peripheral data, limited network resource access is required. Full access to all enclave contained information assets is not needed. Initiating an internal proxy server with a strict access security list is recommended (protected Solaris, local/global user access list via Microsoft's NT File System (NTFS) with auditing enabled). The collaborating LAN should be connected via a secure means, either through a data encoder/decoder (KG) or similarly approved security device. Intrusion detection monitoring products should include real-time auditing and tracking capabilities.

*Protected off-site LAN with same security level connecting to main LAN via public WAN (Internet) with main site having a directly connected collaborating site.*

All previously outlined security precautions need to be met (as defined by case studies 1, 2, and 3). The main LAN needs to have a strict access list in place (protected Solaris, local/global user access list via Microsoft's NTFS with auditing enabled). This precaution is to ensure that the connected collaborating LAN is able to access only predetermined enclave information assets, including resources at the main LAN as well as the off-site protected resources. To further ensure that only approved data is exchanged from the off-site LAN to the collaborating agency, it is recommended that guards be installed at both the ingress and egress location on the enclave boundary of the home enclave LAN.

The guards are present to ensure that only approved filtered data is exchanged between trusting and trusted networks/domains. Implemented intrusion detection monitoring products need to include real-time auditing and tracking capabilities.

*Collaborating LAN connecting to protected remote site using main LAN's backbone.*

All previously outlined security precautions need to be met (as defined by case studies 1, 2, and 3). If the *collaborating* LAN needs to connect directly to the off-site LAN without accessing any main LAN resources the following need to be addressed:

- A router or layer 3 switch is needed at the point of presence of the main LAN.
- A static route needs to be configured to route traffic directly to the off-site LAN via the main LAN's backbone.
- Data traffic needs to travel over the main LAN's encoders/decoders and through its DMZ.
- A guard needs to be installed at the boundary of the off-site LAN.



## UNCLASSIFIED

### Firewalls

IATF Release 3.1—September 2002

The purpose of this type of configuration is to prevent a direct association between an off-site and collaborative LAN (i.e., a foreign organization/agency that is communicating with a local company or agency, the main LAN, acts as a go-between).

- For this case and the associated scenarios, the recommended boundary protection procedures are similar to the previous recommendations, but require higher-assurance boundary protection technology implementations. The following recommendations should be implemented as a comprehensive package with reference to which scenario the network most resembles.
- Institutionalize boundary security awareness and procedures. As outlined in Chapters 3 and 4.
- Configure the home enclave network using built-in features and services for boundary protection. Installation of firewall and or comparable firewall feature set technology.
- Enable available audit capabilities to include firewalls, ingress and egress points and auditing of attempted resource connections.
- Scan for viruses using current virus definitions and profiles. Ensure that definition file databases are no more than a couple of weeks old.
- Perform a non-hostile vulnerability scan. Non-hostile scans include scans of HTTP, FTP, POP, SMTP, SNMP, ICMP, Telnet, Netbios, ensuring no deviations from initial network baseline scan.
- Frequently perform comprehensive vulnerability scans including scans for non-standard UDP/TCP ports, unauthorized protocols, shares, unencrypted passwords, potential operating system-related vulnerabilities.
- Incorporate enterprise-wide intrusion detection. Intrusion detection methods should include the ability to proactively monitor packets, log and alert appropriate personnel based on level of threat/probe, identify and record routing addresses of threat initiator(s).
- Incorporate infrastructure attack “early warning.”
- Employ supplementary boundary protection between off-site locations. (firewall/guard services).
- Couple scanning, monitoring, testing, and intrusion detection. A network is only as strong as its weakest link. By coupling scanning, monitoring, testing, and intrusion detection, weaknesses and potential threats can be identified upon first appearance or during the manifestation stage.

## 6.1.7 Enclave Boundary Protection Framework Guidance

The technologies discussed in this section and the types of techniques they employ should typically be composed to form a solution set to defend the enclave boundary. Although the technologies overlap, each focuses on a different subset of security countermeasures. Additional access control mechanisms should also be used in forming mitigation approach sets. These include encryption or application-layer discretionary access controls to permit or deny access to specific data within an enclave. Given these countermeasures, it must be determined how, where, in how many places, and how many times they should be applied. Places to which the countermeasures can be applied include at the enclave boundary, workstation/LAN interface, individual workstations, servers, operating systems, or at the application level. A layered security approach can be used, determining how many places a countermeasure should be applied. How many times a countermeasure should be applied is the choice between per session authentication and per packet authentication. It must also be determined how strong the security measures must be.

A number of factors generally influence the selection of firewall approaches. The mission needs and services desired by the users are primary factors in shaping mitigation approach sets. The risks to a given system must be assessed in terms of:

- The differences in information value and threat between the protected enclave information assets and the external networks to which it is connected.
- The environments and architecture.
- The impacts of potential attacks.

In addition, cost, policy mandates, scalability, maintainability, and overhead (including performance degradation and manpower) must be considered. Clearly, the specific protection approaches and products selected also must be those that can address the specific services, protocols, operating systems, applications, and components employed in the user's environment. Ideally, the technologies that incorporate all prescribed countermeasures, at the appropriate levels, and addressing all aspects of the specific user environment should be implemented. As indicated in Section 6.1.5, Firewall Technology Assessment, and below, there are gaps in successful achievement of countermeasures, performance, and other areas.

Potential negative impacts are associated with any of the technology solutions. Desired performance of a firewall must be determined when implementing a firewall to defend the enclave boundary. There is a trade-off between speed and security. A network can be more secure when the firewall performs more checking on the packets. However, the amount of checking that a firewall performs has an effect on the volume and the speed at which traffic can transverse the enclave boundary protection.

## UNCLASSIFIED

Firewalls

IATF Release 3.1—September 2002

In addition, while greater restrictions to operations do yield greater protection of the enclave assets, the restriction of dangerous operations also restricts useful operations. There comes a point at which the tradeoff for greater security becomes more than the users want to pay in lost capability or hampered performance. For example, some antiviral and disinfectant (subversion-constrained) software may actually do as much damage to operational performance as viruses themselves might. Some systems may fail to prevent infections but prevent the user from eliminating the virus. Some antiviral systems may actually delete files without alerting the user or offering alternative approaches. Disinfecting has been known to leave workstations in a worse state than the infection did. The primary approach to selection of security protection should be to maximize benefits while minimizing harm. Only through a comprehensive risk analysis, with knowledge of the characteristics and trade-offs of different technologies and specific products including cost and resource constraints, can effective enclave boundary protection be implemented and maintained.

The first step in any effort to implement an enclave boundary protection mechanism and additional technology to protect the enclave information assets is to develop a security policy. The boundary protection mechanisms will then serve to implement this security policy. An in-depth requirement analysis forms the basis for the development of the policy and subsequent selection of protection devices.

Clearly, the environment in question will dictate the level of security robustness. For example, in connecting enclaves of different classifications, whether through a direct connection or through another network, additional security precautions must be taken. Remote access to the enclave through the boundary protection mechanism will require security mechanisms designed specifically for this situation. Firewalls, for example, generally have the capability to form an encrypted link to the remote user. Boundary protection mechanisms, which are used inside the enclave to limit access to restricted information, on the other hand, tend to be cheaper and less complex than those devices located at the boundary of the entire enterprise. Firewall technology has evolved so that firewalls are now developed and marketed specifically for intranet firewall applications.

In addition to the specific environment in question, there are a number of general trade-offs, which should be addressed when implementing firewall technology. One important trade-off with regard to firewall technology is between security and ease-of-use. The more rigorous the checks for user identity and user activity, the more inconvenience the user must endure. On the other hand, if the firewall simply passes everything through to the internal network, security is inadequate, even for the least sensitive data. In choosing a firewall, both the needs of the users for services and the security requirements must be balanced; otherwise, the users will find ways to bypass the firewall, weakening the protection of the enclave boundary.

Packet filters and stateful packet inspection technologies focus on flexibility. In general, these firewalls are able to support many services, and additional services can be easily added. However, this flexibility comes with a price. It is quite easy to configure these types of firewalls to permit dangerous access to services through the firewall. The ease-of-use administrative interfaces and preconfigured support for many services lend themselves to configuration errors. Application gateways, on the other hand, provide better auditing and finer grained control. For

example, application gateways can be used to allow certain activities, such as sending a file to an untrusted network, while blocking a user from copying a file from an untrusted network. In general, router-based firewalls are best for a dynamic environment where lots of things change in a short time frame. Application-level firewalls are better if a more deliberate approach to security is necessary.

Other considerations in selecting a firewall include the skill level available for maintaining the firewall. As noted above, proper configuration and maintenance of the firewall is a critical security element. If an organization does not have the staffing to assign qualified personnel to operate and maintain the firewall, there are options to purchase firewall maintenance services, from either the firewall company or the ISP. These costs of staffing or services should be considered, as well as the corporate credentials of the firewall vendor, and the quality of the documentation available with the firewall.

## UNCLASSIFIED

Firewalls  
IATF Release 3.1—September 2002

### References

1. B. Frasier. Site Security Handbook RFC 2196. September 1997  
<http://www.ietf.org/rfc/rfc2196.txt?number=2196>.
2. SOCKS. 1 May 2000 <http://www.socks.nec.com>.  
FTP Directory. 1 May 2000 <ftp://ftp.nec.com/pub/socks>.
3. Rekhter Y., et al. "Address Allocation for Private Internets. RFC 1918." February 1996  
<http://www.ietf.org/rfc/rfc1918.txt?number=1918>.
4. Ferguson P. and D. Senie. "Network Ingress Filtering: Defeating Denial of Service Attacks which employ IP Source Address Spoofing." 18 May 2000  
<http://www.ietf.org/rfc/rfc2267.txt?number=2267>.
5. AAA Working Group. "Criteria for Evaluating AAA Protocols for Network Access." 26 April 2000. On line posting. 11 May 2000  
<http://www.ietf.org/rfc/rfc2989.txt>.
6. FORTEZZA Cryptography of the 21<sup>st</sup> Century. 12 May 2000.  
<http://www.fortezza-support.com>.
7. Pretty Good Privacy Software. 12 May 2000 <http://www.wtvi.com/teks/pggp/>.
8. General Dynamics Communications System. 12 May 2000 [www.gd-cs.com](http://www.gd-cs.com).

### Additional References

- a. Cisco Systems, Inc. "How Data Moves Through The Firewall." 19 May 2000  
[http://www.cisco.com/univercd/cc/td/doc/product/iaabu/pix/pix\\_v41/pixcfg41/pix41int.htm#xtocid297201](http://www.cisco.com/univercd/cc/td/doc/product/iaabu/pix/pix_v41/pixcfg41/pix41int.htm#xtocid297201).
- b. Computer Security Resource Center. 1 May 2000 <http://csrc.nist.gov/>.
- c. Internet/Network Security. 1 May 2000  
<http://www.netsecurity.about.com/compute/netsecurity>.
- d. Defense Information Systems Agency. Firewall Configuration Guide, 12 June 1998.
- e. Internet/Network Security site. "The Secure Telecommuters FAQ" Page 10 May 2000  
<http://netsecurity.about.com/compute/netsecurity/library/weekly/aa020200c.htm>.
- f. National Security Agency/Network Boundary IA. Department of Defense Firewall Guidance. Version 1.0 Draft, 31 March 2000.
- g. Network Vulnerability Analysis and Penetration Testing. 8 May 2000  
<http://www.blackmagic.com/assessment.html>.
- h. The Source of JAVA™ Technology. "Applets." 8 May 2000  
<http://www.java.sun.com/applets/index.html>.

**UNCLASSIFIED**

Firewalls  
IATF Release 3.1—September 2002

- i. United States Navy Web Information Service. 12 May 2000  
<http://infosec.navy.mil/products/securevoice/stu3.html>.  
Enter at <<http://infosec.navy.mil>>, then, navigate to:  
<http://infosec.navy.mil/products/securevoice/stu3.html>.

**UNCLASSIFIED**

Firewalls  
IATF Release 3.1—September 2002

**This page intentionally left blank.**

## 6.2 Remote Access

Remote access enables traveling or telecommuting users to securely access their Local Area Networks (LAN), local enclaves, or local enterprise-computing environments via telephone or commercial data networks. Remote access capability draws on both the virtual private networks (VPN) and the Defending the Enclave Boundary sections of this document. The remote access user connects by a shared commercial path, and can maintain the privacy of his or her connection using encrypting modems, technologies applicable to VPN needs (as discussed in Section 5.3, System-High Interconnections and Virtual Private Networks), or other technologies suitable to this requirement. Because the user entry point into the enterprise-computing environment could be used by a hostile connection, the enterprise must implement enclave boundary protection (as discussed in Section 6.1, Firewalls). The remote user's computing assets are also physically vulnerable, requiring additional protection. This section draws on the preceding two and explores protection for information storage to address the specific problem of remote access.

Note that although section 5.3, System High Interconnections and Virtual Private Networks, discusses VPNs, the discussion in that section focuses more on 'tunneling' data between enclaves over public networks or private networks of equal or lesser classifications. The discussion also covers what is termed 'bulk-encryption,' where it is an all or nothing protection paradigm. In the context of remote access, a more up-to-date definition of a VPN is a protected communications channel that protects data-in-transit between two points concurrently with unprotected data over a common, untrusted communications infrastructure. Therefore, this section will also discuss the importance of VPNs for the remote access user.

### 6.2.1 Target Environment

Within this section, traveling users and telecommuters are both treated as remote users. However, the environment of these two groups differs in the degree of physical exposure of the remote computer. The traveler's computer is vulnerable to theft and tampering while the user is in transit and while their computer is in storage. These risks are particularly great overseas. The telecommuter's computer is also vulnerable to theft and tampering, but to a much lesser extent if the physical location of the hardware is within Continental United States (CONUS). In addition, because the telecommuter's remote location is relatively fixed, additional steps can be taken for physical protection that are not feasible for traveling users. Conversely, the telecommuter's fixed remote location makes targeting by an adversary easier than in the case of mobile traveling users.

As depicted in Figure 6.2-1, remote users access their enterprise-computing environments by communication paths shared with others. Many remote users employ the Public Switched Telephone Network (PSTN) to access their home enclave directly or use the PSTN to connect to a data network such as an Internet Service Provider (ISP) that connects users to their enterprise-computing environment. Other remote users employ broadband communications technologies, including digital wireless service, cable modems, Integrated Services Digital Network (ISDN), and other high-data-rate media. Remote access via these networks increases the level of threat and imposes architectural constraints to the security solution. This section of the Information



Assurance Technical Framework (IATF) treats remote access, via these networks, separately from direct dial-in to an enterprise-computing environment via PSTN.

Note that for this section, remote access is limited to the capability of providing access to the information contained in users' local system-high LANs, enclaves, or enterprise-computing environments from remote locations, which, during the period of connectivity, are assumed to be controlled at the same system-high level as the local system. In other words, remote users with authorized access to unclassified information that is either sensitive or not will be given access to the unclassified information contained in their local unclassified system-high enclaves and remote users authorized access to secret information will be given access to secret information contained in their local secret system-high enclaves.

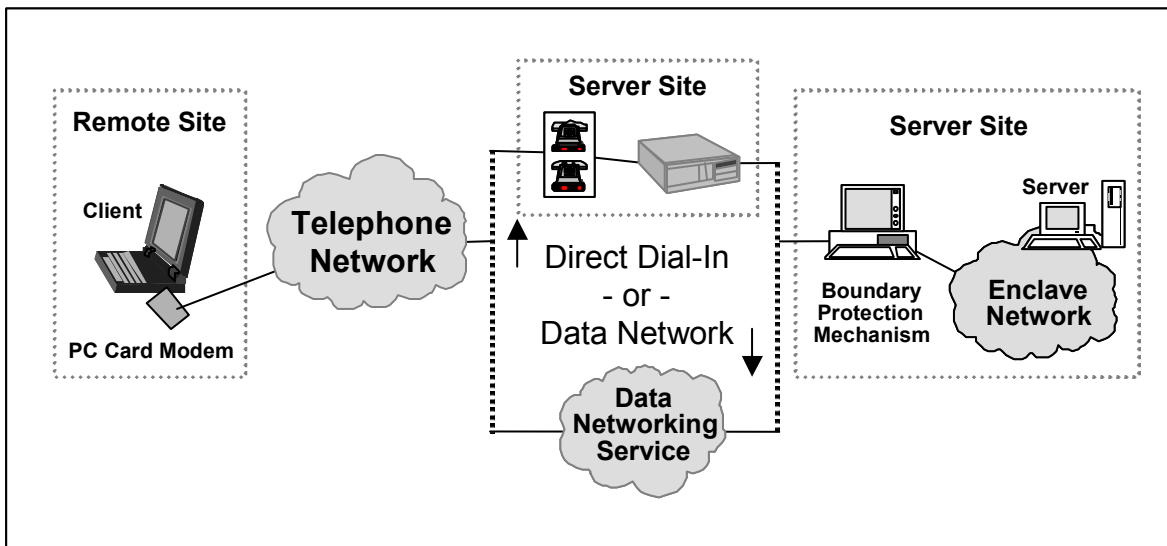

Figure 6.2-1. Typical Remote Access Environment

In the case of secret remote connectivity, the proposed remote connectivity approach will give the remote user the ability to store information on the remote terminal (typically a notebook computer) hard drive in an encrypted format, thereby declassifying the terminal when it is not in operation. However, during the period of connectivity to the home system, the remote user must provide sufficient physical protection and safeguarding of the secret information being processed.

## 6.2.2 Consolidated Requirements

### 6.2.2.1 Functional Requirements

The following requirements are from the user's perspective.

- Remote users should have access to all information stored on their remote computers, stored on their home enclave workstation, or available within their home enclave

information infrastructure. Because remote users need to conduct their business using familiar tools while traveling to a remote location, cryptographic application interfaces on the remote user's terminal should be similar and have the "same look and feel" as those provided at their home enclave. Applications that may be launched from a system-high enclave as a result of a remote user request, shall continue to support all security services as required by the enclave system security policy and procedures.

- The user should know when security features are enabled. Indications should not be intrusive, but the user should be able to tell easily when security features are working, and more important, when they are not. Feedback to the user is very important in any security solution.
- The security solution should have minimal operational impact on the user. It should not impose a significant performance penalty, or require extensive training.
- The traveling user's security suite should not include any external devices. Some remote users simply do not have room for these devices in their computing packages. Solutions that are unobtrusive to the user (e.g., user tokens and software products) are preferred.
- The remote user's equipment should be unclassified when it is unattended. Both the data stored on the remote user's computer and the approved configuration of the remote user's computer must be protected from unauthorized disclosure, modification, or manipulation when out of the direct control of the authorized remote user. This protection must effectively protect the computer and stored data from compromise if the computer is lost, stolen, or used to communicate with lesser security level authorized hosts. Assuming the data stored on the remote user's equipment is appropriately protected, the user is required to safeguard the terminal as would be required of high-value items.
- The remote user should not have greater access than would be available if accessing the enclave information resources from within the enclave.

## 6.2.2.2 Interoperability

Remote access systems that implement interoperable solutions facilitate the movement of users between organizations and increase the likelihood that the system can be supported and upgraded in the future. Interoperability also provides for the maximum evolution of this security solution in the commercial marketplace. For these reasons, the following interoperability requirement is added.

Security solutions should be based on open standards. The use of proprietary implementations creates significant issues related to interoperability and logistics support. To ensure an effective solution, the remote access mechanism should integrate easily into existing information systems and provide a path for upgrading to emerging technology (as discussed below).

### 6.2.2.3 Emerging Technology

It is desirable that the security solutions be capable of evolving to higher data rates and be adaptable to alternative means of communication, such as cellular telephony, wireless networks and ISDN.

## 6.2.3 Potential Attacks

All five classes of attacks introduced in Chapter 4, Technical Security Countermeasures are of concern in the remote access scenario. Section 6.1, the Firewalls section goes into detail on network attacks. The VPN's section's (Section 5.3) treatment of passive, network, and insider attacks is directly relevant to remote access. Since proper configuration and execution of software is critical to the proper functioning of security mechanisms, distribution attacks are also a concern. Remote access places the user's computer in public environments, adding the possibility of physical attack to the five generic attack classes. With reference to Figure 6.2-2, the following summarizes potential attacks against the remote access scenario.

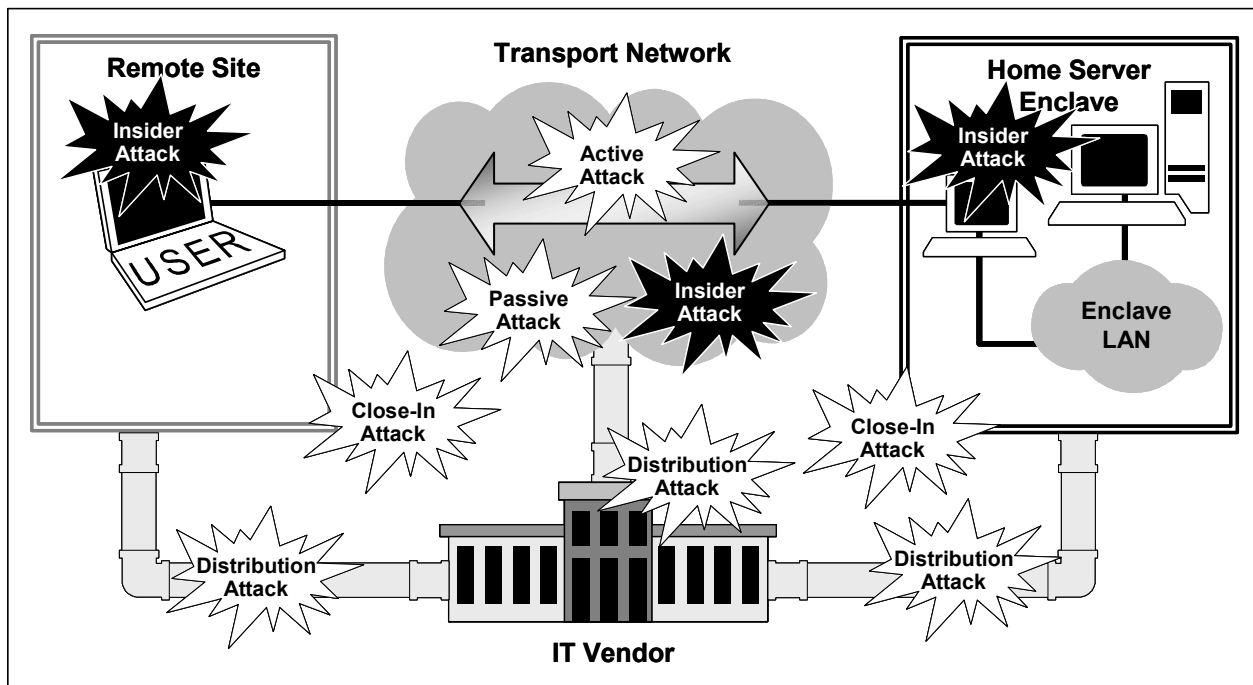

iatf\_6\_2\_2\_0111

Figure 6.2-2. Attacks Against the Remote Access Scenario

### 6.2.3.1 Passive Attacks

An attacker monitoring the network could capture user or enclave data, resulting in compromise of information. Capture of authentication data could enable an attacker to launch a subsequent

network attack. Analysis of traffic captured by passive monitoring can give an adversary some indication of current or impending actions. Compromising emanations could also be intercepted.

### **6.2.3.2 Active Attacks**

These attacks are most likely to originate from the Internet, but, with more effort, could also be mounted through the PSTN. Also attacks can target the remote user's computer, the user's enclave, or the user's connection to the enclave, potentially resulting in the loss of data integrity and confidentiality, and ultimately in the loss of use of the network by authorized users (e.g., a denial-of-service attack).

### **6.2.3.3 Insider Attacks**

An insider is anyone having physical access to the remote user's computer or the network enclave from within the user organization's corporate boundaries. These attacks could be motivated by malice or could result from unintentional mistakes by the user. Deliberate attacks can be especially damaging to the organization's information system due to the attacker's access to the information, their advantage of knowing the network's configuration, and thus their capability to exploit the network's vulnerabilities.

### **6.2.3.4 Distribution Attacks**

Distribution attacks could occur at the Information Technology (IT) provider's site while the product is developed, manufactured and shipped, while the remote user's computer is being configured or maintained, or when software is passed to the user's computer (including software passed over the network). This type of attack could result in a network's device (e.g., firewall, router, etc.) being used to perform a function for which it was not intended, thus making the remote access capability or the enclave vulnerable to attack.

### **6.2.3.5 Close-In Attacks**

The remote user's computer is subject to theft and tampering. Physical attack also could result in the theft of the traveling user's computer, a denial-of-service attack. Typically, there are non-technical countermeasures (e.g., procedures) available for dealing with physical threats. The Framework addresses these since there are also technical countermeasures available that could help to mitigate those threats.

## **6.2.4 Potential Countermeasures**

The following security services are required to counter the potential attacks against the enclave.

- Strong and continuous user authentication should be the basis for allowing access to the enclave. Strong continuous two-way authentication protects the enclave, the remote user, and the connection from network attacks. Cryptography-based authentication at the

enclave boundary ensures that only authorized users can gain access to the network. Use of a boundary protection mechanism is used in conjunction with cryptography-based authentication to provide a basis for controlling a user's access to individual network services. Continuous authentication prevents an unauthorized user from hijacking the remote user's session.

- Confidentiality may be invoked for all information flowing between the enclave and the remote user's computer. Confidentiality guards the enclave and the remote user from passive intercept attacks. Although encryption does little to guard against traffic analysis, the data and metadata (information about data) are protected against direct intercept and compromise. This security service is dependent, of course, on the level of required protection afforded the data.

- The information in the remote user's computer should be protected:

When the computer is not in use. This protects the information in case of theft of the workstation, or unauthorized physical access.

When the computer is connected to unclassified or untrusted networks. This guards against network attacks (e.g., session hijacking) from an unclassified and/or unauthorized network.

- The integrity of the remote user's hardware and software should be protected. Detection and protection mechanisms can guard against distribution attacks, tampering by an outsider, and physical access by an unauthorized user.
- The integrity of data flowing between the remote user's computer and his enterprise-networking environment should be protected. This protection is typically provided at the applications layer. See Section 7.1, Security for System Applications of the Framework for details.

## 6.2.5 Technology Assessment

The three technologies—media and file protection, workstation integrity, and enclave and connection protection—are included in this section and depicted in Figure 6.2-3 counters specific types of attacks. Some attacks, such as tampering, are only partially addressed by technical measures. Non-technical security measures, as discussed in Chapter 4, Technical Principles—physical protection of the laptop, prevention of casual “over-the-shoulder” observation of classified information—are critical to overall system security and should be considered a vital part of a remote access user policy. This section of the Framework only covers those technical measures that will counter attacks relevant to the remote access category.

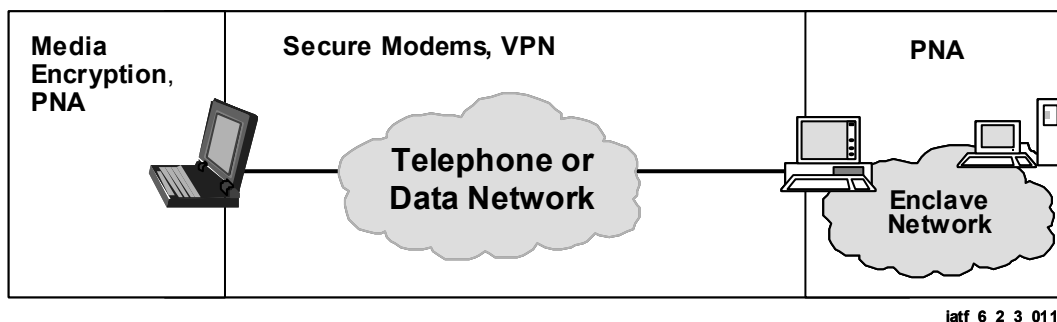

Figure 6.2-3. Security Technologies in the Remote Access Scenario

### 6.2.5.1 Media and File Encryptors

In some cases, physical removal of the remote computer storage media (typically a hard drive) between remote connection sessions is not acceptable. Encryption of the information on the storage media can provide confidentiality and integrity, alleviating the need for physical removal of the media. Media encryptors and file encryptors protect the information in the computer in the event of unauthorized physical access to the computer. File encryptors can protect the confidentiality and integrity of individual files, provide a means of authenticating a file's source, and allow the exchange of encrypted files between computers. Media encryptors protect the confidentiality and integrity of the contents of data storage media. For example, they can help maintain the integrity of the remote user's computer by verifying the Basic Input/Output System (BIOS) and ensuring that configuration and program files are not modified.

With the exception of some system files, media encryptors encrypt the entire contents of the drive. The media encryptors must leave some system files unencrypted so that the computer can boot from the hard drive. The integrity of most of these unencrypted system files can be protected by a cryptographic checksum; this protection will not prevent a tamper attack, but it will alert the user that that data has been altered. System files contain data that changes when the computer is booted and cannot be protected.

File encryptors typically implement a graphical users interface (GUI) that allows users to choose files to be encrypted or decrypted. This protects individual files, but it does not protect all files on the drive. Many applications generate temporary files that may contain user data. These files are normally closed (but not necessarily erased) when the application is terminated. However, the application does not terminate in an orderly fashion; these temporary files may remain open. Some operating systems do not actually erase data when files are closed or deleted. Instead, they alter the name of the file in the file allocation table or de-allocate the storage locations on the media. The user's data then remains on the hard drive until the space is allocated to another file and overwritten. Thus, unencrypted and potentially classified user data can remain on the hard drive after system shutdown, either because of the application's failure to erase temporary files or by the design of the operating system's file closure function. For these reasons, media encryptors provide better protection for the information on the disk drive—especially while the computer is not in use—than do file encryptors.

Media encryption's robustness is an advantage only when proper key management is used in protecting the information. There must be provisions to allow trusted key management to protect the key when encrypting the media and when the key is in storage. See Section 6.2.7, Framework Guidance of this chapter for further discussion of the secret dial-in case. Media encryption also supports workstation integrity, the topic of the next section.

### **6.2.5.2 Workstation Integrity**

Workstation integrity components are necessary to protect the integrity of a remote computer's operation and data against active (network-based) and software-distribution threats. Active attacks include attempts to steal data by circumventing or breaking security features, or by introducing malicious code. The software distribution threat refers to the potential for malicious modification of software between the time it is produced by a developer and its installation and use on the remote user's computer.

Workstation integrity mechanisms to counter active attacks are addressed in the Firewalls section of the Framework. Products for detecting and removing computer viruses are available for both the workstation and boundary protection mechanism. Media encryption protects the configuration and software of the remote user's computer against malicious modification during the operational phase; it does not address this modification during the developmental or the distribution phases. Trusted operating systems can ensure the policy-enforced relationships between subjects and objects, thus limiting any effects the malicious code introduced into the machine might have on the system's integrity.

Software distribution attacks are discussed in Chapter 4, Technical Security Countermeasures. Most software distribution attacks can be thwarted by the use of digital signatures. Software can be signed at the manufacturer before distribution; these signatures are verified before the software is installed on the user's computer. Commercial file encryption packages containing this capability are available.

### **6.2.5.3 Enclave Boundary and Connection Protection**

Components to implement authentication, confidentiality, and integrity mechanisms can operate at several layers in the protocol stack, with trade-offs in assurance, performance, and networks supported. Starting toward the bottom of the protocol stack, options include secure modems, data link layer technologies, network layer products, transport and session layer products, and application layer products. The protocol layer chosen does not necessarily imply a certain level of information assurance. There are mechanisms that can provide either at a high level of assurance, a low level of assurance, or something in-between at any protocol layer. Connection protection is dependent on an organization's risk management decision concerning the level of assurance placed on these mechanisms. All of these approaches, except application layer protocols are discussed in the VPN section (Section 5.3, System-High Interconnections and Virtual Private Networks). The authentication mechanism should provide mutual authentication of the remote user and the enclave's boundary protection mechanism, which is described in the Firewalls and Guards sections (Sections 6.1 and 6.3, respectively) and shown in Figure 6.2-1. It

also shows both options for connecting to the enclave—by direct dial-in to the enclave and by an ISP. Figure 6.2-4 shows the protocol layers associated with the remote access scenario.

### Secure Modems (Physical Layer Mechanisms)

Secure modems offer an inherent means of boundary protection: the identity of the remote user’s modem is established by strong authentication before any network connections are initialized, preventing unauthorized modems from attempting an active attack. The invocation of encryption within a modem provides a high level of assurance provided that the encryption function is properly invoked and is protected from tampering. However, the implementation of additional features, such as plaintext bypass, can reduce some of that assurance. For instance, a secure modem needs a means of bypassing the encryption engine if it is also to interoperate with a nonsecure modem. Any bypass feature in a secure modem must be carefully implemented so it is not possible to bypass the cryptography accidentally or maliciously.

Strong authentication requires a significant cryptographic processing capability both in the calculations required to validate a signature and in the verification of the identity contained in a certificate (e.g., checking against a list of authorized users). The identity that is established by modem authentication may not necessarily be made available to the network. This requires the remote user to log into the network separately.

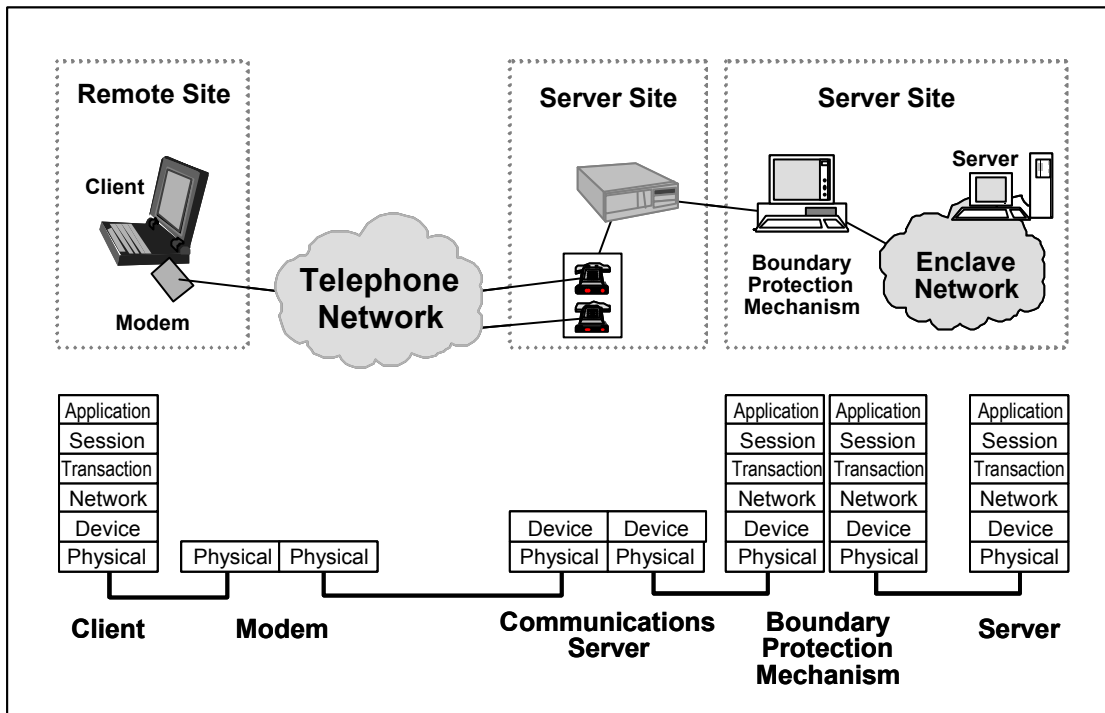

iatf\_6\_2\_4\_0113

Figure 6.2-4. Protocol Layers In Remote Access Scenario



## Data Link Mechanisms

Data link layer protocols such as Point-to-Point Protocol (PPP) and Serial Line Internet Protocol (SLIP) encapsulate network layer packets for transmission via modems. Security services can be applied to these protocols to allow authentication and protect the connection between the remote user and the home enclave's communication server. Unlike the large bandwidth data links discussed in the VPN section, the remote user's data link is dedicated, so authentication of individual users is possible. This assumes, of course, that the remote machine is dedicated to one (and only one) user because authentication at the data link layer relies on lower level physical addresses versus those on higher layers that can distinguish among multiple users (e.g., with user Identifications [ID]).

Data link mechanisms allow users to choose their own modem hardware and upgrade or change it at their convenience, provided that the hardware can interoperate with the enclave's boundary communications hardware. A server implementing a data link mechanism could use the results of cryptographic authentication as a basis for access to the enclave. Data link security mechanisms are likely to be implemented in workstation software, where processing power and memory are more readily available than in the case of special-purpose security hardware. This makes implementation functions such as continuous authentication and certificate path validation more practical. However, it also makes these functions dependent on the integrity of the workstation on which they are running and more vulnerable to implementation errors and subversion.

At the data link layer, no information is available about the network resources or services the remote user is attempting to access. Any filtering mechanism would need to be implemented at a higher layer of the protocol stack.

## Network Layer Mechanisms

Network layer protocols, such as Internet Protocol (IP), assign addresses to devices and pass data packets between them. ISPs assign an IP address to the remote user and pass IP packets for the remote user. For this reason, the network layer is the lowest layer at which security services can be applied in the ISP case. The VPN section addresses IP connections across public networks, and recommends the use of Internet Protocol Security (IPSec) with both Encapsulated Security Protocol (ESP) and Authentication Headers (AH). The VPN section also recommends the use of external encryptors. The current generation of external encryptors must be configured by a trained operator and are expensive and relatively bulky, so external encryptors are currently unfeasible for remote access. However, IPSec mechanisms are implemented in network card hardware, in modem cards, and in software on the user's computer (as before, the proper functioning of software mechanisms depends on the integrity of the user's computer).

Network layer mechanisms allow strong authentication directly from the remote user's computer to the boundary protection device, allowing the boundary protection device to base access control decisions on the user's identity. Network layer information allows the boundary protection mechanism to filter access to individual machines in the enclave. The downside is that they leave all of the enclave's dial-in equipment before the network device—specifically the

modems and the communications server—exposed to network attacks. Provided that the communications servers are properly configured and controlled, the potential for successful attacks against a communications server is relatively low (except for denial-of-service attacks). Remote control and administration of these devices can make the network vulnerable to attack by providing potential access to root level privileges. Please refer to Section 6.1 (Firewalls) for more information.

## Transport and Session Layer Mechanisms

The transport layer forms a reliable channel between devices. The session layer establishes and synchronizes a communication session between two devices. The transport or socket layer is the lowest layer with information on the service being accessed so that security services can be called on a per application basis. The transport and session layers are discussed in the VPN section (Section 5.3). For the remote access scenario, these layers share many of the advantages and disadvantages of network layer mechanisms—they can allow continuous authentication directly to the boundary protection mechanism and allow further access control decisions based on the cryptographically authenticated identity. Transport and session layer mechanisms are not likely to be hardware-based, making them vulnerable to tampering and dependent on the integrity of the user's computer.

The Transport Layer Security (TLS) protocol, which sits at the top of the transport layer, is listed on the Internet Engineering Task Force (IETF) website [www.ietf.org](http://www.ietf.org) as RFC 2246. Product implementations of socket mechanisms should comply with the IETF standard, which is currently TSL.

The Remote Access Dial-in User Service (RADIUS) protocol (RFC 2138) was designed to authenticate remote users using a shared secret. The RADIUS protocol is currently an Internet Draft published by the IETF. Authentication requests are handled by a centrally located authentication server, which provides a method of supporting the management of remote users. The access requests made by RADIUS clients are capable of carrying attributes that include user name, user password, client identification, physical port identification, or other information. When passwords are present, they are protected by using RSA MD5. The ability of RADIUS to support a wide range of client attributes used in access control decisions makes this protocol very flexible. Access privileges can be varied for each user, as well as for the access method each user attempts. Maintaining a central RADIUS server, which controls the privileges for each user, makes RADIUS authentication scalable to handle large numbers of remote users.

## Application Layer Mechanisms

Application layer security, invoked based on-site policy, supports the highest level of filtering. Individual commands within applications, as well as access to specific machines and services, can be permitted or denied. Application layer mechanisms are discussed in the opening part of the VPN Section 5.3. One of the major shortcomings of application layer mechanisms is that they rely on platforms with minimal trust mechanisms and that connections must be established at a lower level in the protocol stack (network and transport layer) before the application mechanisms are applied. This leaves the machine vulnerable to network attacks that are

unaffected by higher-layer security mechanisms. The other drawback of application layer security is the number of applications that need to be covered. As application protocols evolve, security is usually a secondary consideration. The number of application software packages offered in the commercial market (for example, e-mail packages) makes it difficult to add security services to every package as a retrofit. Efforts to standardize the interface to security services will help this problem, but are ineffective if the vendor is simply not interested in implementing security services in the product.

## 6.2.6 Cases

This version of the Framework does not address remote access of top secret or higher sensitivity level information. By definition, the disclosure of this information can cause exceptionally grave damage to national security. Remote access to top secret information presents extreme risk and should be handled on a case-by-case basis.

This section considers remote access to information at the unclassified level that is sensitive or not sensitive and the remote access to classified information up to the secret level as separate cases. Secure remote access to top secret information may be addressed in future versions of this document.

As depicted in Figure 6.2-5, the two different access paths combined with the two sensitivity levels produce four generic cases: secret dial-in access, secret ISP access, unclassified dial-in access, and unclassified ISP access. For each case, the underlying network options include PSTN, ISDN, and other digital and wireless services.

The specific requirement cases include the following.

- Remote access to secret enclave via direct connection through PSTN, ISDN, wireless connections, and other digital connections.
- Remote access to secret enclave via ISP connection through PSTN, ISDN, wireless connections, and other digital connections.
- Remote access to unclassified enclave via direct connection through PSTN, ISDN, wireless connections, and other digital connections.
- Remote access to unclassified enclave via ISP connection through PSTN, ISDN, wireless connections, and other digital connections.

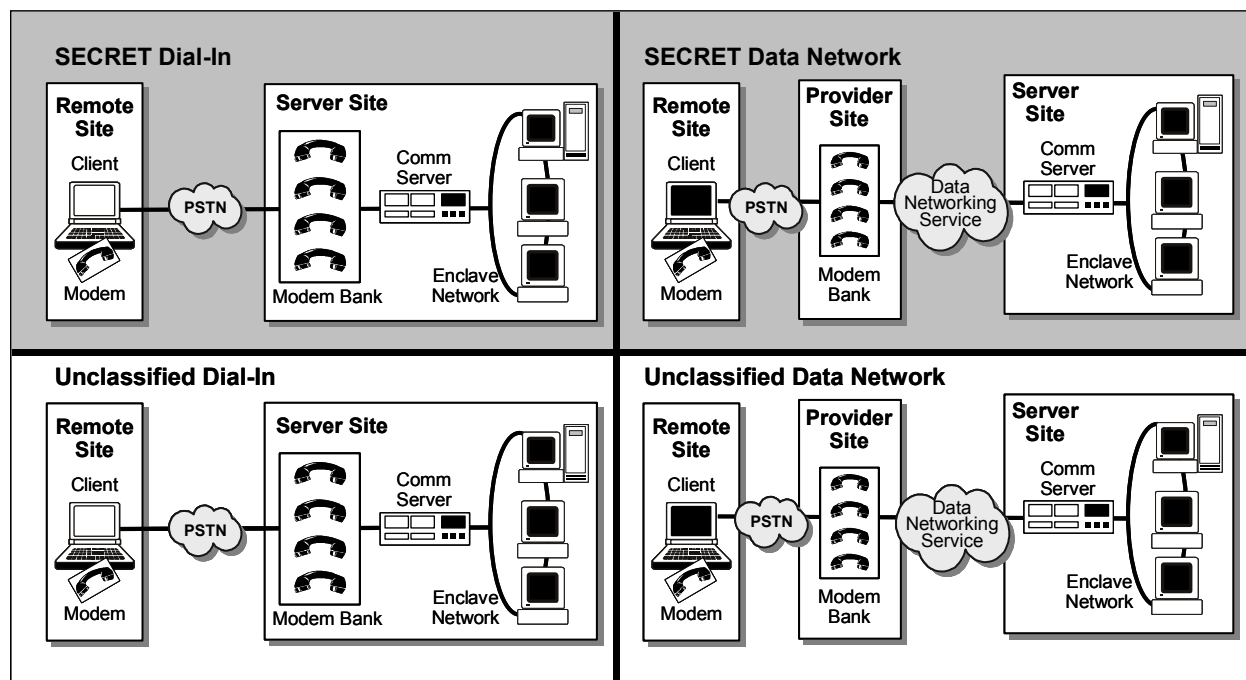

iatf\_6\_2\_5\_0114

Figure 6.2-5. Remote Access Cases

## 6.2.7 Framework Guidance

The following guidance is based on the premise that the home site has properly followed an information systems security engineering process. This process will identify the organization's assets and vulnerabilities and provide a total system solution that mitigates the risk to the level decided by the organization. The discussion here is at a generic level. The level of risk acceptance and the availability of products and services will determine a site's remote access security solution.

### 6.2.7.1 Case 1: Remote Access to Secret Enclave via Direct Connection over PSTN

Guidance for this case is summarized in Tables 6.2-1a through 6.2-1d. Each of these tables is followed by a discussion of the rationale behind the recommendations.

#### Media Encryption

A media encryptor is recommended to protect the information stored in the remote user computer. The rationale for this is that media encryption provides confidentiality for data on the user's hard drive. It also performs a workstation integrity function by protecting the integrity of the computer's configuration; e.g., by verifying the BIOS and making sure that the user is notified of any modifications to applications and hardware configuration files.

**Table 6.2-1a. Summary Guidance for Remote Access  
Direct Dial-up Access to Secret Enclave**

Primary Solution Components	Guidance Categories	Desired Solution	Best Commercially Available Solution	Gap Between Needed & Available Solution
Media Encryptor	Role of this Component	To protect the confidentiality and integrity of all data stored on the hard disk in the event that the user's laptop is lost, stolen, or tampered with.  To keep the laptop unclassified when not in use.	RASP	HARA
	Security Functions	Dynamically encrypt all data (but system boot files) stored on the hard disk.  Protect the private key used to encrypt the data by storing it on a token that is physically removed when not in use.  Require user PIN to unlock the token.	Hardware token-based, software media encryption for Windows platforms	WIN95 and WIN NT versions
	Cryptographic Strength (If applicable)	Cryptographic algorithm and key length should be of robustness level 2.	Type II algorithm (SKIPJACK) w/ 80 bit key	TBD
	Common Criteria Assurance Level	EAL 4	N/A	Three assurance levels
	SMI/PKI/KMI Services	Generation of file encryption keys  Data recovery in event of lost token or user PIN		
	SMI Assurance	KMI level 2	TBD	TBD
	Interoperability Requirements	No requirement	No commercial standards exist. Current solutions are not compatible with each other.	Interoperability

The remote computer needs certain system files in order to boot, so these files should remain unencrypted on the storage media. However, the proper functioning of the media encryptor depends on the integrity of the boot process, so the integrity of these unencrypted system files must be verified. The media encryptor also should verify the integrity of the computer's BIOS configuration. All other space on the storage media should be encrypted. The media encryptor should verify the system's integrity upon boot-up and notify the operator if integrity checks fail.

The media encryptor should use algorithms approved for the protection of secret information. To help mitigate concerns about weak or compromised keys, the media encryptor should be capable of accepting keys from an outside source; e.g., FORTEZZA<sup>®</sup> card and its associated security management infrastructure. The implications of having a split-key are discussed in Chapter 8, Supporting Infrastructures of this Framework. The media encryptor should support both: user and system administrator roles. Only the system administrator should have the ability to change the configuration of the remote computer and the media encryptor. Depending upon the user’s environment and the organization’s security policy, the media encryptor also could be used to preclude the booting of the remote computer via an unencrypted floppy disk. If the remote user wants to access unclassified systems, it is recommended that a separate hard drive be used for this purpose, since the costs of implementing and maintaining a trusted operating system (to maintain data separation and integrity) typically would be prohibitive.

### Remote Workstation Integrity

Recommendations concerning remote workstation integrity are contained in, Section 6.1, Firewalls, and are summarized here. Enclave boundary and protection components should be chosen in accordance with the site’s security policy. The user’s home enclave should choose a network boundary protection mechanism (e.g., guards, firewalls) paying close attention to the tradeoffs among security, performance, and cost. An intrusion detection system may be implemented. A virus scanning policy should be implemented, with scans occurring periodically or after certain events. Network vulnerability scanners should be run periodically, and identified deficiencies should be addressed.

**Table 6.2-1b. Summary Guidance for Remote Access  
Direct Dial-up Access to Secret Enclave**

Primary Solution Components	Guidance Categories	Desired Solution	Best Commercially Available Solution	Gap Between Needed & Available Solution
	Workstation Integrity	Role of this Component	Protect the remote user’s workstation against unauthorized modification	RASP
Security Functions		Digital signature and integrity hash function	Digital Signature Standard and Secure Hash Algorithm	
Cryptographic Strength (If applicable)				
Common Criteria Assurance Level		EAL4	N/A	Three Assurance Levels
SMI/PKI/KMI Services				
SMI Assurance				
Interoperability Requirements				

Remote user and enclave software should be kept up-to-date, since many discovered vulnerabilities are patched in later versions. In addition, software should be protected from tampering by cryptographic checksums applied by the manufacturer and should be checked when the software is installed (on the user’s workstation or the enclave components). New versions of software could also inject new vulnerabilities into the system and thus should be tested before operational use.

Other mechanisms used to protect the integrity of the remote user’s workstation include trusted operating systems, hardware tokens, user password authentication, and so on. At least in the case of a secret enclave, the remote user should be afforded the same protection mechanisms that are provided to the user’s workstation located in the user’s home enclave. In addition, the user’s environment will dictate extra security services, as required by the organization’s security policy. For instance, special policy and procedures are typically required in higher threat environments in which physical security is not at the same level as provided at the home enclave. Additional security mechanisms should give the user the tools to mitigate the loss of workstation integrity.

**Table 6.2-1c. Summary Guidance for Remote Access  
Direct Dial-Up Access to Secret Enclave**

Primary Solution Components	Guidance Categories	Desired Solution	Best Commercially Available Solution	Gap Between Needed & Available Solution
Secure Modem	Role of this Component	Authenticate and encrypt the connection between the remote user and the home enclave	RASP	HARA
	Security Functions	Mutual authentication Continuous authentication Full period encryption at the secure modem layer In-line encryption Hardware device Removable hardware token to store and protect private keys User PIN to unlock token	Encrypting modem supporting KEA and SKIPJACK	
	Cryptographic Strength (If applicable)	Secret	Secret w/ NAG-68 Interim Policy	Secret
	Common Criteria Assurance Level	EAL3	N/A	Three Assurance Levels
	SMI/PKI/KMI Services			
	SMI Assurance	KMI level 2	TBD	TBD
	Interoperability Requirements	Support for AT command set and communications protocol standards Software compression	56Kbps.X.90	Interoperability

## Enclave Boundary and Connection Protection

A link-encrypting device should be used to protect the communications link between the remote user and its home classified enclave. To be used in a classified environment, the device must provide strong authentication and confidentiality services. Modems should meet the applicable commercial standards, such as V.nn and MNPnn. The modem should provide an AT commands interface. To authenticate the remote user to the modem, the modem should require the entry of a personal identification number (PIN) to enable the encrypted data mode. The modem must pass I&A information to the boundary protection mechanism for system access (See Section 6.2.5, Technology Assessment). GUI software should be provided to allow the entry of the PIN and it should display authenticated identities and security modes of operation. The modem may have a plaintext mode of operation (other than that required by the initial handshaking done before a secure session is established). Use of this mode should require overt action on the part of the user so this mode is not selected by accident or by default. Explicit requirements for secure modems will be provided in later releases of the Framework.

In addition to the encrypting modem, a boundary protection device should identify and authenticate the dial-in user at the point of presence of the classified network to the local PSTN. This is discussed in more detail in the next section.

**Table 6.2-1d. Summary Guidance for Remote Access  
Direct Dial-up Access to Secret Enclave**

Primary Solution Components	Guidance Categories	Desired Solution	Best Commercially Available Solution	Gap Between Needed & Available Solution
Enclave Boundary Protection		Mutual and continuous authentication Full period encryption at the secure modem layer In-line encryption Hardware device User PIN to unlock token	Secure communications server supporting encrypting modem	
<b>Solution Residual Risks</b>		<b>None</b>	<b>Acceptable</b>	<b>Difference</b>

## Authentication Mechanism

An additional authentication mechanism should be implemented that will provide strong authentication directly to the boundary protection mechanism to implement a “that which is not explicitly permitted is denied” policy. For example, many remote users only need e-mail while they are traveling; in addition, some may need access to a particular file server. Providing the minimum access needed to do the job not only mitigates the effects of any successful attack by an outsider, but also makes insider attacks more difficult. Guards and firewalls provide this functionality.



Authentication to the user's workstation is recommended. A password, hardware/software token, or biometric device should be used, depending upon the level of assurance required. See Section 6.1, Firewalls, for more information on this issue.

## Technology Gaps

The only government off-the-shelf (GOTS) solution supporting the remote access user is the AT&T Secure Telephone Unit (STU)-III 1910 Secure Data Device (SDD). The SDD runs at data transfer rates much lower than those of modems available in today's commercial market. A cumbersome device, the 1910 is actually heavier and larger than the laptop it supports. There is a consensus in the user population that there is no technology available today. No technology currently provides a high enough level of assurance to pass classified data over the PSTN to and from a classified enclave at the same level of performance that is available in non-encrypting commercial off-the-shelf (COTS) modems. This gap is certainly noticeable when comparing capabilities with the 56 Kbps modems on the market today.

In general, there is a technology gap in high-assurance security solutions applicable to remote access in the COTS environment. In particular, little commercial work is being done on media encryptors, although several file encryption products are available. File encryptors are not widely available for non-Windows operating systems. A few commercial encrypting modems are available, but high-assurance encrypting modems are not commercially available. In addition, secure remote access servers and communication servers are not widely available. Support for top secret remote access will require additional features that are not available in today's commercial marketplace, at least at an acceptable risk level. Workstation integrity and configuration guidance are also issues. Future versions of this Framework will address these gaps in more detail.

### 6.2.7.2 Case 2: Remote Access to Secret Enclave via ISP Connection

This section will be provided in a future release of the Framework.

### 6.2.7.3 Case 3: Remote Access to Unclassified Enclave via Direct Connection

The recommended solution for this case involves implementing a RADIUS server within the enclave and configuring each remote workstation with a RADIUS client. When a remote workstation requests access to the network, RADIUS-based authentication is used.

- **Media Encryption.** In this scenario, all information is unclassified. Therefore media encryption is not necessary for information stored on the remote workstation. File encryption may be desired for protection of unclassified information that is sensitive or not sensitive.

- **Workstation Integrity.** An unclassified remote access workstation will also likely have access to the Internet. There may be a requirement for the remote workstation to download files from the Internet or to exchange files with the unclassified enclave. Downloading files from the Internet poses a risk to the workstation's integrity. The workstation should have a robust and updated virus scanning capability. Additionally, the workstation connecting to the enclave poses a risk to the integrity of the enclave if precautions are not taken to check for viruses on the workstation. Again, to protect the integrity of the workstation and the enclave, virus scanning should be resident on the remote workstation.
- **Enclave and Connection Protection.** The enclave is vulnerable to unintentional virus insertion through the remote workstation. Although RADIUS-based authentication of remote workstations prevents unauthorized remote workstations from gaining access to the enclave's network, there is still a risk of valid workstations being lost or compromised.

All workstations should be equipped with a robust user-to-workstation authentication mechanism. Although in the case of workstation theft or compromise, this mechanism alone may not provide adequate assurance that the workstation cannot be used to access the enclave. A way of mitigating the risk of such access is by implementing an incident report procedure for reporting lost or compromised remote workstations and by installing and maintaining an intrusion detection system. If a lost or compromised workstation is reported in a timely manner, the RADIUS server can be configured to deny access from that compromised workstation. If the compromised workstation establishes a connection to the network before the compromise is reported and mitigated, an intrusion detection system will identify anomalous behavior and alert administrators to the possibility of a compromised workstation.

Although the user information in this scenario is unclassified, there still may be a requirement to provide confidentiality for the connection. A VPN solution can be established across the remote connection. A layer 2 mechanism, such as L2TP, or a layer 3 mechanism such as IPSec may be implemented to provide confidentiality. These technologies are discussed in further detail in Section 5.3.

- **Authentication Mechanism.** Authentication between the remote workstation and the home enclave is achieved by using the RADIUS protocol. The RADIUS protocol relies on a shared secret between the RADIUS client and the RADIUS server. MD5 is used to hash the shared secret, the user password, and other fields in the RADIUS message. The strength of the authentication is based on protecting the shared secret.

Authentication to the user's workstation also is recommended. A password, hardware/software token, or biometric device should be used, depending on the level of assurance required.

## 6.2.7.4 Case 4: Remote Access to Unclassified Enclave via ISP Connection

The recommended solution for this scenario involves implementing an IPSec-compliant firewall or other boundary protection device. Remote workstations must be configured with an IPSec-compliant network card, software, or other component. This case also involves implementing a RADIUS server within the enclave and configuring each remote workstation with a RADIUS client. In this scenario, the remote workstation usually uses the PSTN to establish a connection to the ISP. The ISP then interfaces with the Internet, which interfaces with the enclave. The remote workstation establishes an IPSec-secured connection over the PSTN that terminates at the enclave ISP-compliant firewall or boundary protection device.

- **Media Encryption.** In this scenario, all user information is unclassified. Therefore, media encryption for information stored on the remote client is not necessary. File encryption may be desired for protection of unclassified information that is sensitive or not sensitive.
- **Workstation Integrity.** An unclassified remote workstation also will likely have access to the Internet. There may be a requirement for the remote workstation to download files from the Internet or to exchange files with the unclassified home enclave. Downloading files from the Internet poses a risk to the workstation's integrity. The Internet-connected workstation connecting to the enclave poses a risk to the integrity of the enclave if precautions are not taken to check for viruses. Therefore, to protect the integrity of the workstation and the enclave, a robust and updated virus scanning capability should be resident on the remote workstation.
- **Enclave and Connection Protection.** The enclave is vulnerable to unintentional virus insertion through the remote workstation. Although RADIUS-based authentication of remote workstations prevents unauthorized remote workstations from gaining access to the enclave's network, there is still a risk of valid workstations being lost or compromised.

All workstations should be equipped with a robust user-to-workstation authentication mechanism. Although in the case of workstation theft or compromise, this mechanism alone may not provide adequate assurance that the workstation will not be used to access the enclave. A way of mitigating the risk of such access is by implementing an incident report procedure for reporting lost or compromised remote workstations and by installing and maintaining an intrusion detection system. If a lost or compromised workstation is reported in a timely manner, the RADIUS server can be configured to deny access from that compromised workstation. If the compromised workstation succeeds in establishing a connection to the network before the compromise is reported and mitigated, an intrusion detection system will identify anomalous behavior and alert administrators to the possibility of a compromised workstation.

Although the user information in this scenario is unclassified, there still may be a

requirement for confidentiality. If confidentiality is required, the IPSec client on the remote workstation can use the ESP feature of IPSec to encrypt the IP payload.

- **Authentication Mechanism.** Authentication between the remote workstation and the home enclave is achieved by using the authentication header of IPSec. The IPSec authentication header relies on a shared secret using either a symmetric encryption algorithm (i.e., Data Encryption Standard [DES]), or a one-way hashing algorithm (e.g., MD5, HA).

Authentication to the user's workstation also is recommended. A password, hardware/software token, or biometric device should be used, depending on the level of assurance required.

**UNCLASSIFIED**

Remote Access  
IATF Release 3.1—September 2002

**This page intentionally left blank.**

## 6.3 Guards

Guards enable users to exchange data between private and public networks, which is normally prohibited because of information confidentiality. A combination of hardware and/or software guards is used to allow secure local area network (LAN) connectivity between enclave boundaries operating at different security classification levels (i.e., one private and the other public). Guard technology can bridge across security boundaries by providing some of the interconnectivity required between systems operating at different security levels. Several types of guards exist. These protection approaches employ various processing, filtering, and data-blocking techniques in an attempt to provide data sanitization (e.g., downgrade) or separation between networks. Some approaches involve human review of the data flow and support data flow in one or both directions. Information flowing from public to private networks is considered an upgrade. This type of transfer may not require a review cycle, but should always require a verification of the integrity of the information originating from the public source system and network. This section discusses guards, the environment and mannerism in which they are most suited for implementation, how they can be used to counteract attacks made on the enclave, and the variety of guards and their functions.

A guard is a device used to defend the network boundary by employing the following functions and properties:

- Typically subjected to high degree of assurance in its development.
- Supports fewer services.
- Services are at the application level only.
- May support application data filtering (review).
- May support sanitization of data.
- Typically used to connect networks with differing levels of trust (provides regrading of data).

### 6.3.1 Target Environment

The guard is designed to provide a secure information path for sharing data between multiple system networks operating at different security levels. The overall system that employs a guard is illustrated in Figure 6.3-1. The system is composed of a server, workstations, malicious code detection, a firewall, and/or filtering routers all configured to allow transfer of information among communities of users operating at different security levels. The server and workstation components may implement a hardware- or software-based authentication scheme to authenticate to the guard. The firewall component is usually commercial off-the-shelf (COTS) hardware and/or software that filters the network traffic and is configured to forward only authorized packets. A commercial filtering router may also be used to perform this function. The firewall's primary function is to provide barriers against successful penetration of the low side LAN by

unauthorized external users. The firewall hides the networks behind it and supplements the guard. The firewall restricts access to all traffic other than the traffic being scrutinized by the guard. Virtual private networks (VPN) can also be employed using either a firewall or other encryption device. To ensure the security of the overall system, all users, managers, and system administrators must exercise the security policies and practices of the organization. Some considerations include valid personnel approval for access to all information stored and/or processed on the system; formal access approval process for, and signed nondisclosure agreements for all information stored or processed on the system; valid need-to-know process for some of the information stored or processed by the system. Communication links, data communications, and data networks of the system must protect the network determined by the sensitivity level of data on that particular network.

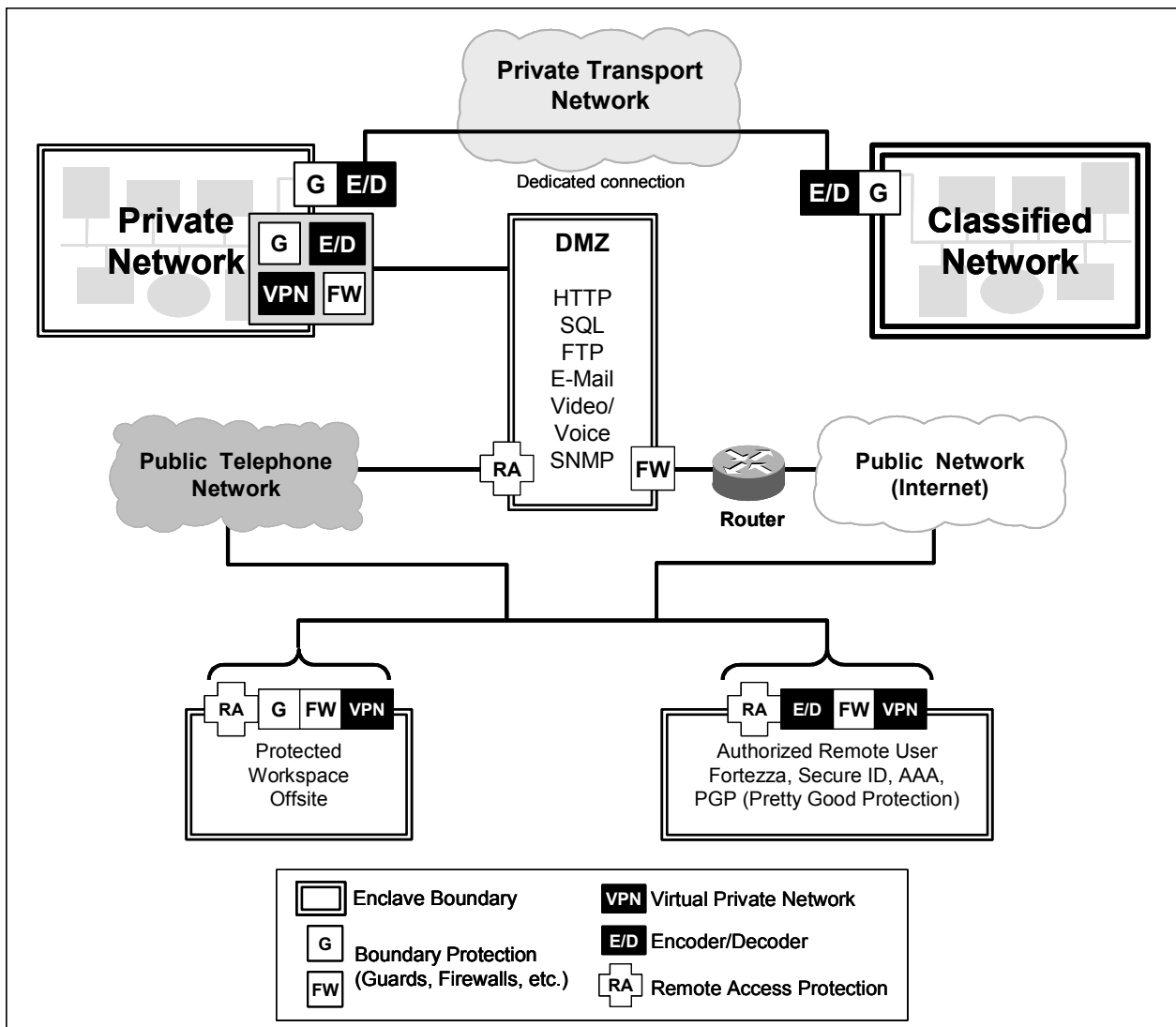

latf\_6\_3\_1\_0027

Figure 6.3-1. Guard Environment

The guard can be configured to function in different directions.

- The private to public bidirectional mode facilitates data to move from private to public after the review process for releasability to the lower network classification. Data moving from low to high need not undergo the review process for releasability, but processing, filtering, and blocking should occur to identify viruses and other malicious code transfers. Private network users would be allowed to push public data to public network users, and in turn, users on the public network could push public data to users on the private network. Private network users would also be allowed to view and pull data that exists on the public network.
- The private to public unidirectional mode allows data to move from private to public after the review process for releasability to the lower network classification. No transfer is permitted from the lower network to the private network. Private network users would send data to be downgraded to the public level, which would then be pushed to a server on the public network for subsequent pull by users on the public network.
- The peer-to-peer mode allows communications between networks bridged by the guard at the same security level (e.g., private and private releasable)—that is, all the screening the guard normally performs on private to public transfers in the private to public configuration is performed in both directions. Standard operating procedures must be implemented so that appropriately cleared personnel from each side can administer the guard screening criteria databases. This configuration allows private network users to downgrade data to the private-releasable level and to push that data to a server on the private-releasable network for subsequent pull by users on the private-releasable network.

## 6.3.2 Requirements

This section addresses the functional requirements of the communication, releasability, and network access capabilities.

### 6.3.2.1 Communication Requirements

Requirements for communication include the following:

- The guard shall allow users on the private networks to communicate with only specified hosts on the public networks.
- The guard shall prohibit workstations to be used as a pass-through or gateway device from either the private or public sides for any communications, including mail.
- The guard shall send public data to one of the public networks or private networks using the appropriate router.
- Routers shall be configured to restrict the types of network services that may pass through them as well as the sources and destinations of service requests.



- The guard shall transfer the appropriate data from the private network to the public network.
- The guard shall allow protocols to pass through it.
- The guard shall allow only authorized users to send and/or receive a message by performing access control on both the source and destination addresses of the message.

### **6.3.2.2 Releasability Requirements**

Current requirements for releasability include the following:

- The guard shall allow only a properly labeled message to pass from the private level to the public level.
- The guard shall support a policy that allows only attachments that have been reviewed for security level at the user's workstation to pass from the private-to-public side.
- The guard shall allow only selected application attachments to pass through it—this capability will be configurable to support a variety of application packages.
- The guard shall perform word and/or phrase search.
- The guard shall support rule-based sanitization (i.e., message content modification) of messages from high levels through low levels.
- The guard shall ensure that only allowed data is distributed.
- The guard shall validate proper message construction, including configurable verification of message content.
- The guard shall remove classification labels, which were inserted into the e-mail body and attachments prior to delivery to the other side.

### **6.3.2.3 Access Requirements**

Current access requirements for file transfers include the following:

- The guard shall run on a trusted platform.
- The guard shall prevent message flow directly between the private side wide area network (WAN) and the guard in either direction.
- The guard shall support a programmable set of security identification (ID) labels per flow.
- The guard shall ensure that the security level of a message subsumes (is equal to or greater than) the security level of its attachment(s).

- The guard shall protect against unauthorized disclosure of private side information.
- The guard shall provide safeguards to protect the private side from attacks (including penetration, malicious code, and denial of service) from the public side.
- The guard shall support user authentication and encryption capabilities.
- The guard shall perform audit all security-related functions.
- The guard shall provide an access control mechanism to limit access to the controls and provide separate roles for the security administration, system operator, and mail administration functions. Thus, a supporter authorized to function in one area will be prevented from performing functions in another, unless specifically given permission to do so.
- The guard shall prevent disclosure or release data to unauthorized consumers.
- The guard shall provide a secure bridge for passing messages between networks of differing levels of security.
- The guard shall strip off the digital signature as the message passes through the guard.
- The guard shall restrict source routing. Source routing, which is a form of addressing, can alter the routing of a message from its normal route.
- The guard shall journal/log all passed and/or failed messages.

### 6.3.3 Potential Attacks

The focus within this category is on attacks into an enclave by malicious e-mail, file, or message transfers. Guards can be implemented to provide a high level of assurance for networks by preventing certain types of malicious messages from entering the enclave. The types of attacks are categorized into three sections: Section 6.3.3.1, Active Attacks; Section 6.3.3.2, Distribution Attacks; and Section 6.3.3.3, Insider Attacks. For more information related to attacks, please refer to Chapter 4.2, Adversaries, Threats (Motivations/Capabilities), and Attacks.

#### 6.3.3.1 Active Attacks

Active attacks attempt to breach security features or exploit data in transit, whether it be e-mail, file, or message transfers. Some firewall technologies and e-mail systems that perform content filtering will help establish a level of trust for messages that are signed but not encrypted. Messages may be signed and/or encrypted at the user level and/or the organizational level. However, a digital signature on a message does not increase the safety level for the message contents. Active attacks may include the insertion of malicious code or the theft of data. Examples of active attacks in regard to the transmission of messages and files are listed below. For further description of network-based attacks, please refer to Section 4.2.1.4.2, Network-Based Vulnerabilities and Active Attacks.

## UNCLASSIFIED

Guards

IATF Release 3.1—September 2002

- **Modification of Data in Transit.** Modifications are not necessarily always malicious or intentional. A modification could be the conversion of spaces to tabs or vice versa within an e-mail or real-time message. A network-based modification could also be the occurrence of a complete violation of standards. Internet e-mail standards necessary for the secure transmission of messages from one domain to another are Pretty Good Privacy (PGP); Multipurpose Internet Mail Extensions (MIME); and Secure Multipurpose Internet Mail Extensions (S/MIME). Although instant/real-time messaging do not yet have interoperable standards established, protocols must be established to ensure that the messages have not been intercepted and corrupted.
- **Insertion of Data.** Reinsertion of previous messages.
- **Inserting and Exploiting Malicious Code** (e.g., Trojan horse, trap door, virus, and worm).
- Defeating login mechanisms into e-mail accounts, messaging accounts, or file storage servers.
- **Session Hijacking.** In the case of e-mail, file or real-time message transfers unauthorized access could be gained into a communications channel with malicious intent.
- Denial of service.
- Establishment of unauthorized network connections.
- **Masquerading as an Authorized User.** An attacker would use the identification of a trusted entity to gain unauthorized access to information either by e-mail, real-time messaging, or requesting file transfers.
- Manipulation of data on the private side.
- Decrypting weakly encrypted traffic.
- **Misrepresentation or information “faking” through Internet relay attacks.** Third-party mail relay occurs when a mail server processes and delivers e-mail from an external client. In this manner, mail appears to originate from that mail server’s site and not the original site. Spam e-mail is generally distributed this way, at the mail owner’s expense. Intruders can spam e-mails with embarrassing content or by flooding a site with e-mails. Damage caused by spamming includes not only the loss of reputation of the system that has been identified with the attack e-mail but also the loss of connectivity to large parts of the Internet that have blocked sites from spamming. E-mail servers will become clogged, mail can be lost or delivered late, and cleanup costs will be incurred to remove spammed mail without destroying legitimate mail.
- **Monitoring Plain Text Messages.** Plain text messages are not encrypted, and therefore not secure in any manner. Once intercepted, plain text messages can be easily read.

### **6.3.3.2 Distribution Attacks**

Distribution attacks can occur anytime during the transfer of a guard's software and/or hardware. The software or hardware could be modified during development or before production. The software is also susceptible to malicious modification during production or distribution. Section 6.3.4.2 discusses methods in which these attacks could be prevented. For additional information, please refer to Section 4.2.1.4.4, Hardware/Software Distribution Vulnerabilities and Attacks. Also, refer to Table 4-3, Examples of Specific Modification Attacks.

### **6.3.3.3 Insider Attacks**

Although an enclave must be protected from outside intruders, it must also be protected from attacks from inside the enclave. Interception or attacks to messages can occur during transit from the insider level. The originators' and recipients' mail system administrators are able to look at e-mail messages and files that are being sent. E-mail messages that bounce back usually have a copy sent to the e-mail system administrator to help determine the reason behind the bouncing; therefore, the administration has bounced messages brought to his/her attention with full viewing privileges to the message that is attempting to be sent. An insider attack occurs when someone located within the boundaries of the enclave intercepts or modifies data or security mechanisms without authorization.

Unauthorized access could also be gained into the overhead portion of a covert channel. The use of a covert channel is a vulnerable point of attack as a result of the transport overhead not being completely defined and therefore being susceptible to exploitation. The physical theft of data is another threat within the enclave. For further detail, please refer to Section 4.2.1.4.3, Insider Vulnerabilities and Attacks.

## **6.3.4 Potential Countermeasures**

For all efforts aimed at attacking an enclave through the unauthorized access or modification to e-mail messages, real-time message transfers, or file transfers, measures must be in place to prevent these attacks from penetrating the boundaries of an enclave. In the case of attacks that originate from inside the enclave, precautionary measures also need to be taken in areas vulnerable to attacks, including the physical theft and unauthorized access to data. The following subsections address measures that can be taken to counteract attacks against an enclave and information transfers among enclaves. These countermeasures are placed into three categories: Section 6.3.4.1, Boundary Protection Via Guards; Section 6.3.4.2, Distribution Attack Countermeasures; and Section 6.3.4.3, Insider Attack Countermeasures.

### **6.3.4.1 Boundary Protection Via Guards**

Guards can be implemented to protect the enclave and the messages passing within and through the enclave boundaries. Guards enable users to exchange information between either networks of the same or differing classification levels. Traffic analysis is a means by which traffic can be

## UNCLASSIFIED

Guards

IATF Release 3.1—September 2002

monitored. Traffic analysis can be conducted to help identify traffic patterns (i.e., origination and destination endpoints for traffic), and thus aid in the discovery of the endpoints of unauthorized network connections. Enclave boundaries need protection from the establishment of unauthorized network connections. The responsibility lies with the management and administration of the local network to prohibit unauthorized connections between networks of different classification levels and to enforce this policy through nontechnical means.

The following bulleted items list the type of attack and the countermeasure that can be used to prevent that attack from occurring.

- **Modification of Data in Transit.** The countermeasure to this attack is to use digital signatures or keyed hash integrity checks to detect unauthorized modification to the data in transit. E-mail, real-time messaging, and file transfers are all susceptible to interception and modification while in transit.
- **Insertion of Data.** Many countermeasures exist for the malicious insertion of data. They include the use of time stamps and sequence numbers, along with cryptographic binding of data to a user identity, to prevent the replay of previously transmitted legitimate data. Data separation or partitioning techniques, such as those used by guards and firewalls, deny or restrict direct access and the ability to insert data during transit.
- **Inserting and Exploiting Malicious Code (Trojan horse, trap door, virus, and worm).** Implement a guard and employ strong authentication in order to filter and block incoming messages that are not from authenticated parties. To help ensure that mail is neither modified during transit nor forged, technologies and products such as PGP and S/MIME can be used to encrypt and sign messages on a regular basis. Real-time messaging protocols are necessary to also ensure authentication among parties.
- **Defeating Login Mechanisms.** The most appropriate countermeasure for this attack is the cryptographic authentication of session establishment requests. This effort pertains to logging into an e-mail account or to obtaining access to a file server or messaging channel.
- **Session Hijacking.** The countermeasure for this attack is continuous authentication through digital signatures affixed to packets, or at the application layer, or both.
- **Denial of Service.** Countermeasures that can be taken against these attacks include having a guard to filter out bad source Internet Protocol (IP) addresses, filter Internet Control Message Protocol (ICMP) echo responses or limit echo traffic, and guard against all incoming User Datagram Protocol (UDP) service requests. A nontechnical countermeasure would be to subscribe to the certification and accreditation (C&A) Computer Emergency Response Team (CERT) mailing list ([www.cert.org](http://www.cert.org)) in order to receive notifications every time a new Internet weakness emerges. [2]
- **Establishment of Unauthorized Network Connections.** A nontechnical countermeasure lies with the management and administration of the local network to prohibit and enforce the policy against unauthorized connections between networks of different security levels. Commercial tools also are available for system administration

personnel to use for detecting unauthorized connections. Unauthorized connections would allow for otherwise prohibited access to e-mail and data files and for real-time message interception.

- **Masquerading as an Authorized User.** The appropriate countermeasure is to use cryptographic authentication in conjunction with time stamps or sequence numbers to prevent any recording and/or replay of authentication data, whether it be e-mail, real-time messaging, or file transfers. Another countermeasure to prevent stealing an authentic session is to cryptographically bind authentication data to the entire session or transaction.
- **Manipulation of Data on the Private Side.** The appropriate countermeasure is to permit only authorized users to access the data, through file transfers, on the private side using cryptographic authentication and data separation techniques.
- **Decrypting Weekly Encrypted Traffic.** To ensure that unauthorized persons cannot access e-mail messages, real-time messages, or files in transit, adequate encryption algorithms and sound key management processes must be observed.
- **Misrepresentation or Information “Faking” Through Internet Relay Attacks.** The countermeasure for these spamming attacks would involve the use of a guard to filter the messages and therefore block malicious messages, whether they are e-mail messages or real-time messages, from entering the enclave.
- **Monitoring Plain Text Messages.** The monitoring of messages can be counteracted by denying access to the data by unauthorized users. Access denial is possible by encrypting the data or by using other data separation techniques that will restrict those who are unauthorized from obtaining access to the data contained within a file.

### 6.3.4.2 Distribution Attack Countermeasures

During the development, manufacturing, and distribution stages, technical and nontechnical measures must be taken to avoid the malicious modification of guard software and hardware. The following lists the stage at which an attack could occur and the countermeasure to prevent such an attack.

- **Modification of Software or Hardware During Development, Prior to Production.** Strong development processes and criteria are essential during this phase as a countermeasure for threats. Continuous risk management through processes, methods, and tools is also necessary. The following Web site link contains a collection of software engineering processes, methods, tools, and improvement references, <http://www.sei.cmu.edu/managing/managing.html>. [3] Subsequent third-party testing and evaluation of software should also be conducted to ensure that the software and hardware have not been modified. High-assurance methods and criteria should be followed, such as the Trusted Product Evaluation Program (TPEP) and Common Criteria. Please refer to <http://www.radium.ncsc.mil/tpep/tpep.html> for program details. [4]

- **Malicious Software Modification During Production and/or Distribution.** The countermeasures for threats during this phase are high-assurance configuration control, cryptographic signatures over tested software products, use of tamper detection technologies during packaging, use of authorized couriers and approved carriers, and use of blind-buy techniques.

### 6.3.4.3 Insider Attack Countermeasures

Technical and nontechnical countermeasures must both be taken to prevent against attacks originating within the boundaries of an enclave. The following are the types of insider attacks that can occur and the countermeasure that must be taken to prevent the attack.

- **Modification of Data or Modification of Security Mechanisms by Insiders.** The primary technical countermeasure is to implement auditing procedures of all actions taken by users that could pose a threat to security. Audit logs will need to be generated and timely, diligent reviews and analysis must be conducted. Nontechnical countermeasures include personnel security and physical procedures.
- **Physical Theft of Data.** Appropriate nontechnical countermeasures include personnel security and physical security procedures, which inhibit actual removal of data, either in printed form or on storage media.
- **Covert Channels.** The countermeasure against a covert channel between networks of different classification levels is a trusted guard function that examines network header fields and network messages for possible unauthorized information.

### 6.3.5 Guard Technology Assessment

Guards are usually used to enable connectivity that is normally prohibited because the information requires confidentiality. Where a firewall is usually used to restrict or scrutinize information flow on an already existing link to LAN or WAN circuits, guards allow the transfer of information between segments operating at different security classification levels (one private and the other public). A combination of hardware and software components is designed to allow this connectivity between segments. Most guard implementations use a dual network approach, which physically separates the private and public sides from each other. As shown in Figure 6.3-2, guards are application specific; therefore, all information will enter and exit by first passing through the Application Layer, Layer 7, of the open systems interconnection (OSI) model. In addition, most guard processors are high-assurance platforms that host some form of trusted operating system and trusted networking software.

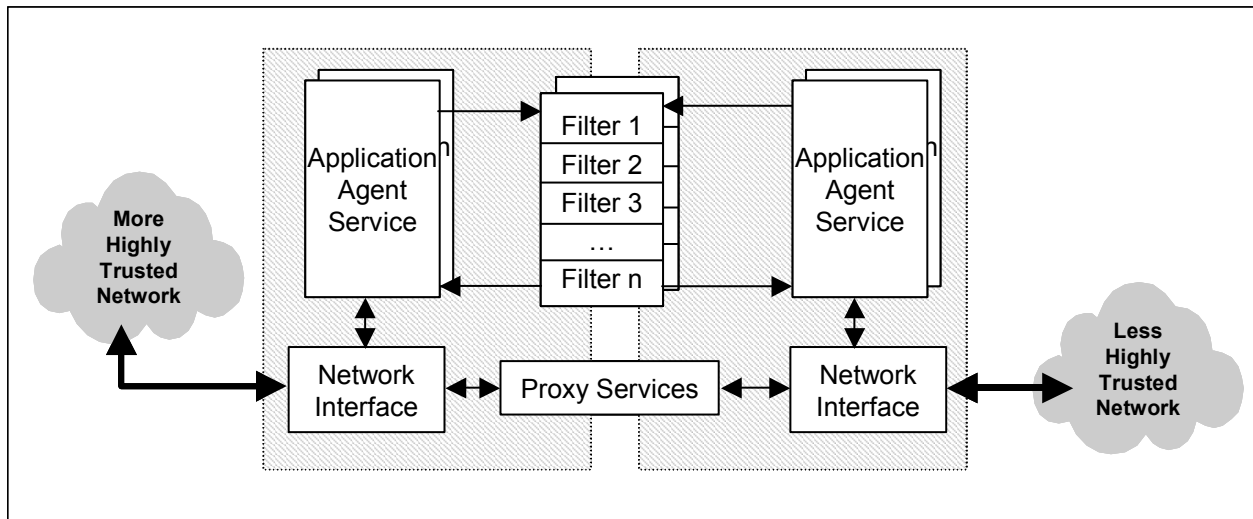

iatf\_6\_3\_2\_0028

**Figure 6.3-2. Dual Network Approach**

A guard can be a fully automated (without any human intervention) multilevel security (MLS) guard system that permits one-way or bidirectional transfers of data among multiple LAN systems operating at different security or releasability levels. Guards can concurrently review and sanitize multiple binary and American Standard Code for Information Interchange (ASCII) files and virtually any complicated data format. Almost any data type that can be “packaged” into a file can be transferred through certain guards, including structured query language (SQL), HyperText Transfer Protocol (HTTP), UDP, Simple Mail Transfer Protocol (SMTP)/e-mail attachments, and others. The guard controls the automated information flow among multiple LAN systems according to security rule filters. When implemented in conjunction with a firewall, a higher degree of security for protecting the enclave is achieved.

This section is further broken down to discuss guard technological areas that can be used to protect the enclave:

- Authenticated Parties Technologies.
- Confidentiality and Integrity.
- Data Processing, Filtering, and Blocking Technologies.

This categorization allows for a high-level assessment of system assurance so that a determination can be made as to the level of security robustness a network will require. These three categories of potential protection approaches are explained in more detail in the following subsections.

### 6.3.5.1 Authenticated Parties Technologies

Approaches for protecting the enclave that are included within this category are those that mandate the use of cryptographic authentication mechanisms before allowing access. Authentication allows two parties that intend to exchange data to identify themselves to one



another and positively authenticate their identities. Hence, they become mutual trusting parties. The data flowing between these trusting parties is at the lower security level. Authenticated access is widely available and is supported by a large number of standards and protocols. Authentication protects the enclaves of private users that are separated from public network users through an enclave boundary protection device, such as a guard and/or firewall. In such a topology, public network users might use digital signature technology to authenticate themselves to private network users. In addition, the guard might incorporate access control list (ACL) mechanisms to make access decisions governing the set of users that is authorized to release information from the private network. The ACLs can also be used to restrict the set of public network users that are authorized to push data up to the private network. The enclave boundary protection system might also perform content review of the data submitted for release. Protection approaches that use authenticated parties are discussed below.

User and document authentication can be achieved with the digital signature and FORTEZZA technologies. Guards can check data packets for digital signatures or user identification and authentication (I&A). Based on this information, guards can accept or deny traffic from entering the enclave. The enclave boundary protection system cannot perform the functions of inspecting the contents of the message or verify the digital signature if the message is encrypted. Messages must be able to be decrypted before processing through the guard so that the guard will be able to perform filtering on the message contents.

## Digital Signature

The digital signature, which is the result of encrypting a document using the private key of the signer, can be applied to spreadsheets, Word documents, e-mail messages, portable document format (PDF) files, and others. A digital signature is a string of numbers that is the representation of the document. Using a digital signature ensures that the contents of a document cannot be altered; doing so would invalidate the signature. A digital signature is unique to both the signer and the document; therefore, user and document authentication can be achieved. However, the signature cannot provide confidentiality to the data contents.

An important note is the difference between the digital signature and a digitized signature. A digitized signature is simply the visual form of a handwritten signature to an electronic image. A digitized signature can be forged, duplicated, and cannot be used to determine if information has been altered after signature.

## Hardware Tokens

Hardware tokens, which can be used to identify and authenticate users, include One-Time Only Passwords, FORTEZZA, and smart cards (the latter two are addressed in more detail below). One-Time Only Passwords protect against unauthorized access by providing dynamic user authentication. A personal identification number (PIN) along with a code that changes very frequently (e.g., every 30 to 60 seconds) is requested from the user for I&A. A guard will process this information to permit or deny access. By requiring two factors of authentication,

greater protection is provided against unauthorized access than with the traditional fixed password.

## **FORTEZZA**

FORTEZZA is a registered trademark held by the National Security Agency (NSA) that is used to describe a family of security products that provides data integrity, originator authentication, nonrepudiation, and confidentiality. FORTEZZA is an “open system,” allowing for seamless integration with most data communication hardware platforms, operating systems, software application packages and computer network configurations and protocols. This technology uses a cryptographic device: a personal computer (PC) card called the FORTEZZA crypto card. This card contains the user’s unique cryptographic key material and related information and executes the public key cryptologic algorithms. The FORTEZZA card enables users to encrypt, decrypt, archive data, and generate digital signatures. The card uses the Secure Hash Algorithm, Digital Signature Standard, Digital Signature Algorithm, and the Key Exchange Algorithm. A guard can identify and authenticate the originator of a message based on a digital signature. However, a guard must be able to decrypt traffic before determining permissibility into an enclave. If a guard is unable to decrypt data, then the information will be denied from passing through the guard and entering the enclave.

## **Smart Cards**

The use of smart cards is another technological method in which users can be identified and authenticated. A smart card is a plastic card embedded with a computer chip that stores and exchanges data between users. Smart cards provide the tamperproof storage of user and account identity and add to system security for exchanging data across any type of network. They can serve as a means for network system, application, or file access because smart cards can be used to obtain access to a computer or even e-mail accounts. Insertion of the card or proximity to an antenna is required to be able to “read” the information on the card using a smart card reader that can be attached to a computer. Users can be authenticated and granted access based on preset privileges. A guard can authenticate and identify users and thus determine access privileges into an enclave based on the information provided from the smart card.

## **Secure Sockets Layer**

Secure Sockets Layer (SSL) is a popular security protocol for implementing privacy and authentication between communicating applications. This transport layer security protocol enables the encryption and authentication of arbitrary applications. The protocol prevents eavesdropping, tampering with information, and forging of information sent over the Internet.

The SSL protocol includes a lower level protocol (called the SSL Record Protocol) that encapsulates higher level security protocols. The SSL Handshake Protocol is one such encapsulated protocol. It allows communicating parties to authenticate one another and to establish cryptographic algorithms and keys at the start of a communication session. For more information about SSL, please visit <http://welcome.to/ssl>. [5]

Connections using SSL have three properties:

- The communication is private. The initial handshake uses public key cryptography to define a secret key. The secret key is then used with symmetric cryptography to encrypt all communications.
- Clients and servers can authenticate one another during the handshake using public key cryptography.
- The entire communication is protected against tampering or insertion of data. Each datagram has a message authentication code that is a keyed hash value.

The SSL protocol can be used for network access between clients on the private side and servers on the public side. By checking a server's identity, confidence is obtained that the server is trusted to some degree. A policy requiring that SSL be used for all network access between private and public networks would effectively permit access to only those servers on the public side that are able to authenticate using SSL. However, the goal should not only be authentication; rather, the goal should be access control, with authentication being a means to implement access control. This is accomplished by maintaining a list of public servers and directories that, once authenticated, can be accessed by private clients. That ACL is best maintained by an enclave boundary protection system such as a guard.

### **6.3.5.2 Confidentiality and Integrity**

Confidentiality and Integrity can be assured through the following technologies: FORTEZZA, COTS Encryption, Audit Logs, and Operating System.

#### **FORTEZZA**

In addition to the I&A features of FORTEZZA, the cryptographic features of the "FORTEZZA Crypto Card" are employed to offer confidentiality and integrity. The integrity protection is provided primarily when data served from a server or client is key hashed (via the Secure Hash Algorithm Federal Information Processing Standards Publication [FIPS PUB] 180). [6] Confidentiality is accomplished with preencryption of the data to be served from the server, and the encryption/decryption of all data passed from a server to a client and from a client to a server (via the Key Exchange Algorithm and SKIPJACK Algorithm FIPS PUB 185). [7] These cryptographic features also include not only digital signature capabilities, but also associated key and certificate management infrastructure support. FORTEZZA encryption and decryption functions include the following:

- Interface to and function with any government-certified FORTEZZA Cryptographic Card for encryption and decryption.
- Do not corrupt the integrity of a file's data content.

- Ensure that the resultant decrypted file retains the original file's attributes (e.g., if the original file was read-only, then when that file is decrypted after being encrypted, it shall retain the read-only attribute).
- Be able to encrypt and decrypt files of all types.
- Inform the user if the encryption and decryption process succeeded or failed.
- Verify that any signature on the certificate is valid (based on the public key from the issuer's certificate).
- Allow the originator to select the type of protection to be applied to the message: signed-only, encrypted-only, or signed and encrypted.

## Commercial Off-the-Shelf Encryption

Some guard products incorporate COTS encryption algorithms, such as triple Data Encryption Standard (DES). Although these algorithms are not suitable to protect classified information, they may be used to segregate communities of interest in a protected environment. For example, two users with different privileges at the same classification level may use a commercial encryption algorithm to logically and reliably segregate their traffic. Other organizations that do not possess classified traffic, but rather sensitive traffic, may allow commercial algorithms to provide data confidentiality. In either scenario, commercial encryption may be used on the enclave side of the guard to provide logical data separation.

## Audit Logs

Audit logs maintain a record of system activity by system and application processes and by user activity of systems and applications. In conjunction with appropriate tools and procedures, audit logs can assist in detecting security violations, performance problems, and flaws in applications and ensure data integrity. A computer system may have several audit trails, each devoted to a particular type of activity. Auditing is a review and analysis of management, operational, and technical controls. The auditor can obtain valuable information about activity on a computer system from the audit trail. Audit trails improve the accountability and integrity of the computer system. For example, audits can be used in concert with access controls to identify and provide information about users suspected of improper modification of data (e.g., introducing errors into a database). An audit trail may record "before" and "after" versions of records. (Depending on the size of the file and the capabilities of the audit logging tools, this may be very resource intensive.) Comparisons can then be made between the actual changes made to records and what was expected. This can help management determine if errors were made by the user, by the system or application software, or by some other source.

## Operating System

A guard cannot provide any degree of assurance if it is installed on an operating system with well-known vulnerabilities. To be effective, guard software must be developed on a trusted

operating platform. Additionally, the guard software must make effective use of the security mechanisms and services offered by the operating system. Part of the guard development process should be documenting how the guard uses the operating system in an effective manner. Guards built on insecure operating systems should not be considered.

The operation and security level of a guard is dependent on the operating system. The platform must be a trusted operating system with high-level security mechanisms. Hackers who become frustrated while trying to penetrate the guard will try to attack the underlying operating system in hopes of gaining access into the enclave. The operating system must have segmentation of processes to minimize the risk from hacker attempts. Segmentation of processes is the separation of system calls at the operating system level. This segmentation allows applications to use restricted portions of the operating system and denies the user's ability to penetrate different security levels—that is, a separate login and password is required for different command levels of the operating system. Usually, each security level of the operating system will have a limited command set in compliance with the security policy of the operating system. The system administrator should therefore hold a clearance that is at least equal to that of the highest network connected to the guard.

In an MLS environment, the strength of some guards remains within the user workstations and the gateways. Each user workstation and gateway must be installed with a trusted operating system. Guards trust users to make decisions regarding the classification and sensitivity of information. The trusted operating systems control access to information displayed on a user workstation and control the movement of information out of the multilevel network (MLN). The MLN must use a trusted operating system, defined as an operating system accredited to maintain the trust between sensitive information and the authorized users. In the MLN architecture, an authentication server controlling user logins and monitoring network system activity enhances this service.

### **6.3.5.3 Processing, Filtering, and Blocking Technologies**

Protection approaches that fit logically within this category use various processing, filtering, and data-blocking techniques in an attempt to provide data sanitization or separation between private network data/users and public network data/users. Data originating from the private network is implicitly labeled as private data, though it may be asserted to be data of a lower sensitivity level by a private network user. Enclave boundary protection devices such as a guard may perform automated processing and filtering techniques. If such tests are successfully passed, the data is actually regraded by automated means. In the reverse direction, such approaches often incorporate data blocking techniques (typically in firewalls but also in guards) to regulate the transfer of data from public network users to private network users. Use of certain protocols may be blocked and/or data may be processed or filtered in an attempt to eliminate or identify viruses and other malicious code transfers.

Information passed between public and private networks may be encoded as binary information in some applications (e.g., imagery, the size of the piece of information to be processed may be

very large). The guard will have to reconstruct the entire message from multiple packets, which requires large working memory space. Then, the guard must pass the information through filtering and processing rules. With large files, this action may take a nontrivial amount of time. If any of the imagery files are time sensitive (i.e., used as part of a training exercise that requires commands to be issued based on the imagery files), the guard may add delay that degrades the usability of the information.

Note that data transfer between private and public networks involves risks, and one must take steps to mitigate risk. Processing, filtering, and blocking techniques involve inexact attempts to filter private data from outgoing transmission through content checking against a predefined list of prohibited strings. Scanning and detecting virus-infected executables, and blocking executables are also conducted. Because an almost infinite number of possible executables exist and malicious ones can be detected only through prior knowledge of their existence, the problem of detecting “maliciousness” in an arbitrary executable is not computable. Furthermore, the problem is exacerbated by the exist of many executables that users wish to allow to cross the network boundary (e.g., Java applets, Active X controls, JavaScript, and Word macros) and that they would therefore not wish to filter out or block. Only by performing a detailed risk management tradeoff analysis, wherein operational needs are weighed against security concerns, can these issues be resolved.

Protection approaches that use processing, filtering, and blocking technologies rely on processing to allow information flow between two networks while attempting to detect and block the leakage of classified data and attacks. Such approaches include ACLs, malicious code detection, content checking, application/attachment checking, and public to private replication. These approaches are discussed in the following subsections.

## **Access Control Lists**

The ACLs enable users to selectively access information. The ACLs identify which users are permitted access to secure files, databases, programs, and administrative power. Discretionary Access Control (DAC) is used to restrict access to a file. Only those users specified by the owner of the file are granted access permission to that file. Mandatory Access Control (MAC) occurs when the security policy is dictated by the system and not by the object owner. Before access can be permitted or denied, I&A of the user must be available. Guards use the I&A presented by the user to determine if an ACL applies to that user. For example, if an ACL requires authentication via digital signature, then permission will be denied immediately to all users who do not authenticate with a digital signature. When a user authenticates with a digital signature, access permission will be granted if that user is on that ACL.

## **Malicious Code Detection**

Although not a part of the guard itself, malicious code detection is integral to providing the high-assurance level associated with guards. Attachments opened by the guard must be sent to the malicious code detector to scan for known macro viruses or other malicious code. Files that are reassembled must also be scanned for known malicious code. The high assurance that can be

provided by a guard can be undermined easily if the guard is allowed to pass information containing malicious code.

## **Content Checking**

Content checking service scans internal and external e-mail to detect and remove content security threats. Dirty word search filters, which are configurable, may be applied to search for specific words and send rejection messages back to the originators' system. A dirty word search scans messages for certain security-sensitive words, as defined by a word list. The content checking feature can be adequately defined, developed, and verified to evaluate the contents of the data to be transferred through the guard to ensure that no information at a sensitive level is transferred to a lower level system.

## **Application/Attachment Checking**

Part of the application layer assurance offered by guards is application checking. This mechanism protects against attachments possessing improper file extensions. For example, the security policy for the organization may allow Microsoft Word attachments to pass through its mail guard. However, simply inspecting the file extension to verify that it is ".doc" is not enough to assure that the file is actually a Word file. The guard must launch its version of Microsoft Word and attempt to actually open the file. If the file cannot be opened, it either has errors or is mislabeled, and it should not be allowed to pass through the guard. If the file can be opened, it should be passed to a gateway malicious code checker to check for macro viruses. If no macro viruses are found and its message passes all other content checking filters, the attachment may be allowed to pass through the guard.

## **Public to Private Replication**

Public to private replication allows users on a private network to receive data that originates on a public network, without having to explicitly request that the data be sent from the public servers. Replication can be used for network access by pushing data from a public network to a private network. It can give the private network any application that passes messages from one host to another. The primary security property of replication is the prevention of data flows from a private to a public network.

A common example of this technology is a database replication. If a node on a private network requires access to a database on a public server, the database can be duplicated on another server that is reachable by the private network. The guard controls the information flow between the replicated database and the private node. The private node may only have read privileges to the database, and not be able to write, depending on the security policy for the private network. The ability to write to the database would be dependent on the guards' private network and the guards' ability to reliably downgrade information. Other examples of replication are File Transfer Protocol (FTP), e-mail, and Web Push protocols.

Replication does not reduce the potential risk that data replicated into the private network may be hostile executable code. To mitigate this risk, a guard would have to be implemented so that data could be first replicated in this network guard. The guard inspects the data for potentially hostile code and ensures that the data passes this inspection before being forwarded into a private network.

To prevent data leakage from private networks to a public network, replication does not allow a direct back channel to send message acknowledgments from a private network to the public network; doing so would allow a large covert channel. The replication acts as an intermediary, sending acknowledgments to the public sender, and receiving acknowledgments from the private recipient. The public sender cannot determine with precision the timing of the acknowledgments sent from the private side. Hence, the intermediate buffer within the replication process reduces the bandwidth of the back channel. This action disconnects any direct communication from private networks to a public network.

### 6.3.5.4 Cascading

Cascading occurs when two or more guards are used to connect three different networks containing information of three or more different levels. For example, if a top secret and secret network establish an agreement and a connection and the secret network has a preexisting connection to an unclassified network, the possibility exists for a path between the top secret and unclassified network. Please refer to Figure 6.3-3. The security policy for each guard needs to be examined to determine if a possible connection exists between the top secret and the unclassified network. Possible methods to reduce the risk associated with cascading are to allow different services through the two guards or restrict each user to interact with a single guard. When establishing a connection between two different networks using a guard, the connections each network have to other networks needs to be considered.

### 6.3.6 Selection Criteria

When selecting a guard, the following should be taken into consideration:

- The guard should send and receive e-mail between the private network and the public network.
- The guard should conform to standards used in the wider community.
- The guard should allow users to send and receive attachments in both directions.

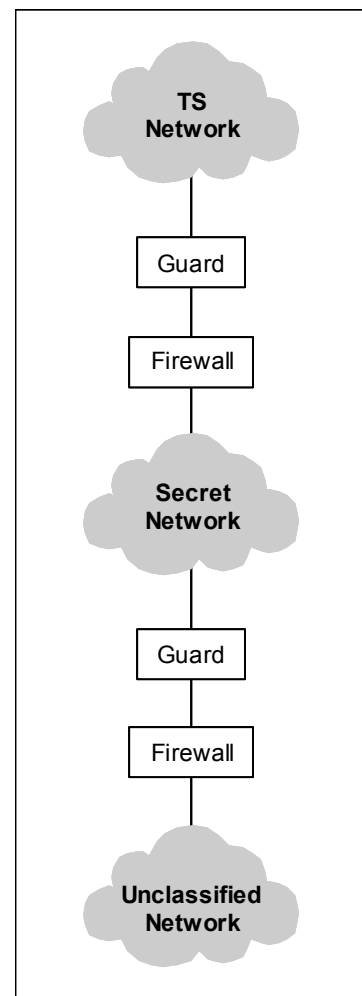

iatf\_6\_3\_3\_0029

**Figure 6.3-3.**  
**Cascading Protection**



## UNCLASSIFIED

### Guards

IATF Release 3.1—September 2002

- The guard should provide a user-friendly and seamless e-mail capability that passes messages with transit times comparable to those of a commercial electronic Message Transfer Agent (MTA).
- The guard should run on a trusted platform.
- The guard should only permit e-mail protocols (SMTPs) to pass through the guard.
- The guard should allow only authorized users to send and/or receive a message by performing access control on both the source and destination addresses of the message.
- The guard should prevent message flow directly between the high side WAN and the guard in either direction.
- The guard should allow only a properly labeled message to pass from the private level to the public level; each message must include a classification label.
- The guard should ensure that the security level of a message subsumes (is equal to or greater than) the security level of its attachment(s).
- The guard should protect against unauthorized disclosure of information from a private network.
- The guard should provide safeguards to protect the private side from attacks (including penetration, malicious code, and denial of service) from the public side.
- The guard should allow word or phrase search.
- The guard should support user digital signatures and encryption applications.
- The guard should support a digital signature or encryption capability.
- The guard should audit all security-related functions.
- The guard should provide an access control mechanism to limit access to the guard's controls and provide separate roles for the security administration, system operator, and mail administration functions.
- The guard should provide rules-based sanitization (i.e., message content modification) of fixed format messages from high levels through low levels.
- The guard should ensure that only allowed data is distributed.
- The guard should validate the proper message construction, including configurable verification of message content.
- The guard should provide secure bridge for passing messages between networks of differing levels of security.
- The guard should downgrade high-level data from designated communications channels according to validated rules.

- The guard should verify that the data meets a set of rigorously controlled criteria.
- The guard should prevent disclosure or release data to unauthorized consumers.
- The guard should communicate with only specified hosts on the public networks.
- The guard should prevent workstations from being used as a pass-through or gateway device from the public sides for any communications, including mail.

## 6.3.7 Framework Guidance

### 6.3.7.1 Case 1: File Transfers From a Top Secret to a Secret Network

This case study represents a situation in which a user on a secret network must obtain files from a user on a top secret network. Major risks are involved when connecting differing LANs. Therefore, when data files are to be transferred between networks of differing classification levels, the requirement arises for a guard that can recognize the FTP. Please refer to the Internet Engineering Task Force Request for Comment (RFC) 959 for additional information about the FTP, <http://www.ietf.org/rfc/rfc0959.txt?number=959>. [8] The guard's function is to permit communication between different classification boundaries while preventing the leakage of sensitive information. Included with the risks of connecting networks of differing classifications is the accidental or malicious release of data from one network to another. Therefore, when files must be transferred from a top secret network to a secret network, a guard can ensure that only permissible files are released. To be capable of this function, a guard should be able to process files regardless of type (e.g., graphic interchange format [GIF], Moving Pictures Expert Group [MPEG] file format, hypertext markup language [HTML]). The file will be subject to review by the established application checking policy to scan the contents and verify the sensitivity level. The guard will then downgrade files to allow releasability of the file to a lower sensitivity level user. Downgrading only occurs if the file's content meets the requirements of the sensitivity level of the network for which the data is being delivered. Downgrading is the change of a classification label to a lower level without changing the contents of the data.

In addition, limits must be placed as to which users have permission to release files from the top secret network and which users on the secret network have permission to obtain these files. The originator of a file will have permission granted through an ACL kept by the guard to release files to the lower level network, secret. In return, the recipient must also have permission granted to access files that were released from the top secret network. Data owners must be able to restrict access to their data, and the system must also be able to deny access. DAC is the access control mechanism that allows the file owners to grant or deny access to users. The file owner can also specify an ACL to assign access permission to additional users or groups. MAC is a system-enforced access control mechanism that uses clearances and sensitivity labels to enforce security policy. MAC associates information requested from a user with the user's accessible security level. If data is classified as top secret, the information owner cannot make the information available to users who do not have access to top secret data. When access is

## UNCLASSIFIED

Guards

IATF Release 3.1—September 2002

restricted, authentication and authorization policies must be in place. Authentication verifies the claimed identity of users from a preexisting label. Authorization is the determination of privileges a user has to grant permission for access of requested information. Authentication and authorization must be performed for all users requesting sensitive files from a user, as shown in Figure 6.3-4. Files may be stored on a server, making the files available to users on the secret networks who have permission to access the files. The server that allows the release of files shall be a COTS product that receives files and places them in a directory so that they will be accessible to authorized users. A guard must also be configurable to allow changes to be made to a database. Changes made to the master database of downgraded data shall be applied to replicated databases in near real time.

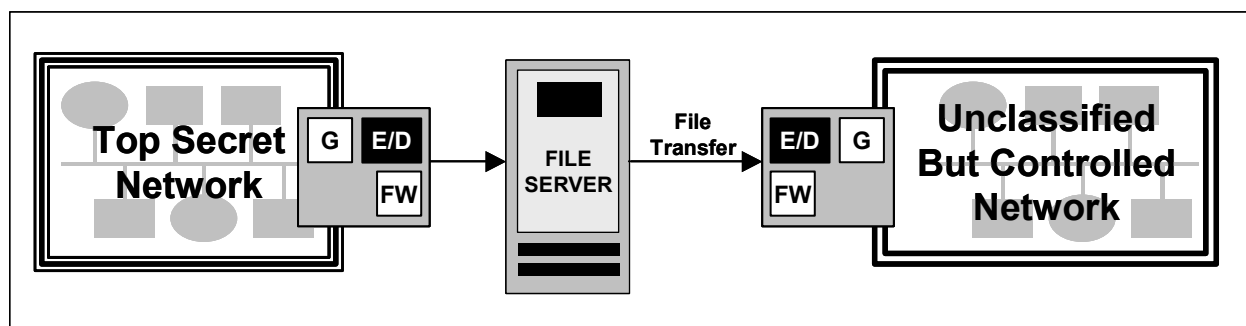

iatf\_6\_3\_4\_0030

**Figure 6.3-4. File Transfers**

In keeping with the established releasability policy for file transfers, the guard will release the data to the lower level (secret) network based on the match of the content label and the security attributes of the recipient. The releasability policy followed by the guard shall adhere to the following:

- The guard shall allow only a very small set of users on the top secret network to release files.
- The guard shall maintain an ACL of these users and check the list every time a file is submitted for release.
- Only files of a specific format (plain text or HTML) shall be releasable.
- Strict audit logs shall be kept on the guard of all released files.
- Released files shall be scanned for content.
- Images contained within a file shall be reviewed.
- All files shall be authenticated (for example, digital signatures).

### 6.3.7.2 Case 2: Releasability From Secret to Unclassified Networks

When opening communication channels between secret and unclassified networks, a determination shall be made as to whether a bidirectional flow of information through a guard will be allowed. Guards differ in that some support only one-way transfers of information, whereas others support a bidirectional flow of information. Releasing information from a secret to an unclassified network can be performed through e-mail transmissions. Therefore, a mail guard is required, as shown in Figure 6.3-5, and can be coupled with a firewall to further enhance the security measures taken to protect the secret enclave.

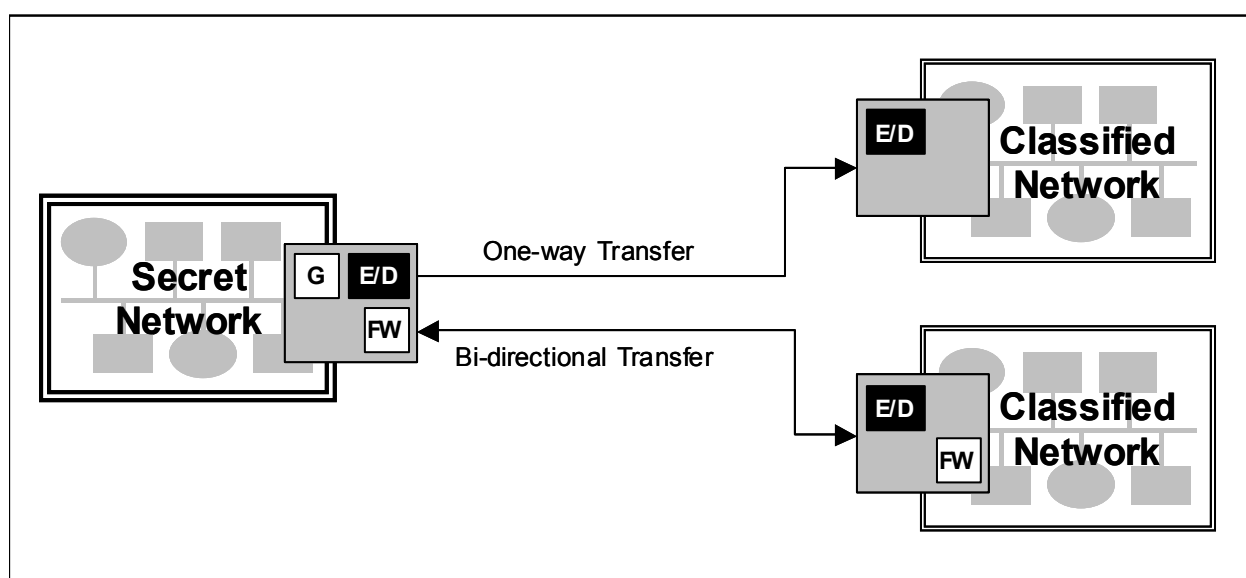

iatf\_6\_3\_5\_0031

Figure 6.3-5. Secret to Unclassified Releasability

The mail guard enforces the policy for release of messages from the secret network. This policy may include the following:

- Content filtering/dirty word search.
- Malicious code checking.
- Message format check.
- Envelope filtering to determine if a sender and receiver are permitted to send and receive messages.
- Authentication (for example, cryptographic digital signatures).
- Message journaling/logging.
- Allowance or disallowance of attachments.

- Review of attachment.
- Allowance or disallowance of mail receipts.
- Allowance and disallowance of sending blind carbon copies of messages.
- Maintenance and review audit logs of all mail message transfers for questionable actions.

Although the goal is to have a guard that has full functionality and can automatically review all information, a human reviewer may also be placed to review messages before the guard receives and reviews messages. A user can manually review messages by being placed between the guards of two separate networks, as shown in Figure 6-3-6. Or, as shown in Figure 6.3-7, a human reviewer can review information before the guard for verification that the sensitivity level of the information can be released to the unclassified network.

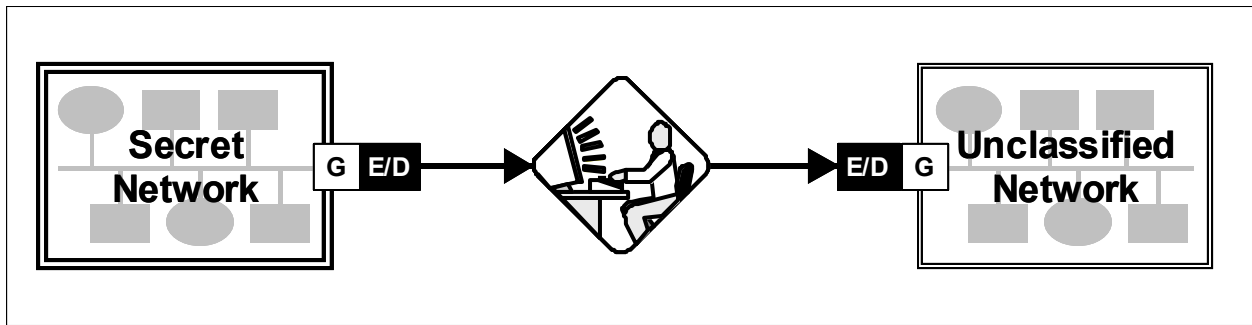

latf\_6\_3\_6\_0032

Figure 6.3-6. Human Reviewer-Man in the Middle

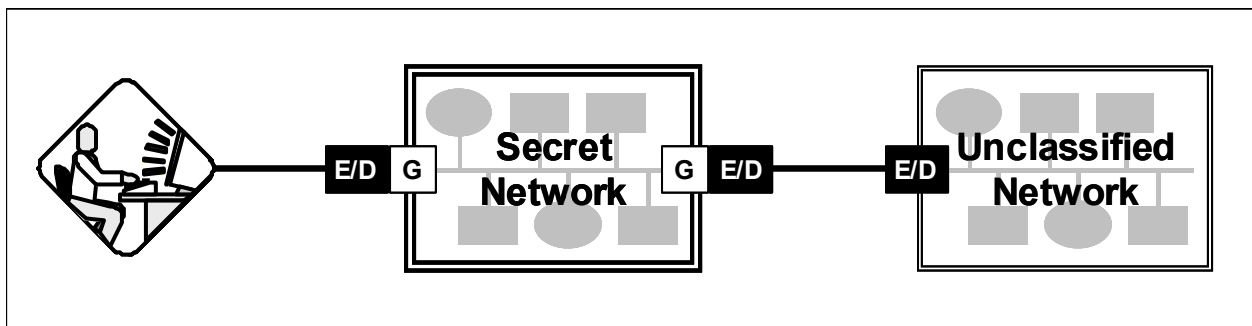

latf\_6\_3\_7\_0033

Figure 6.3-7. Releasability Human Verification

The human reviewer has the release authority over a message with respect to allowing or rejecting the sending of the message. The established security policy may require that all messages are reviewed or only rejected messages are reviewed, or perhaps messages might not need to be manually approved. The functionality goal of a guard is to allow a fully automated review process. A process without a human reviewer must have fully automated guards that are able to check content, check attachments to e-mail messages, have a configurable security filter,

perform dirty word searches, and have imagery processing capabilities. Dirty word searches are looking for words or codes that could be used to disclose sensitive information.

Encrypted messages must be able to be decrypted before processing through the guard, allowing the message to be released. Guards with decryption capability (which may be through embedded FORTEZZA cards) will decrypt a copy of a message and, upon release approval, pass the original message to the recipient and discard the decrypted copy. If a message cannot be decrypted, then the guard must reject that message. A rejection notice policy shall be established to address the handling of message rejection notices. The rejection notice policy may have notices sent to only the mail administrator of the secret network or may also allow rejection notices to be sent to the user. A policy shall also be established as to the allowance of mail receipts.

Confirmation that recipients have received an e-mail can be equally important as the security measures taken to protect the information contained within the e-mail. Mail receipts, however, cannot always be relied on because some e-mail servers will not allow receipts out of their own e-mail system. Therefore, when sending e-mail through a guard, rules must be established regarding the allowance of return receipts. Automatic return receipts may not be part of the guard's security policy. However, once a recipient verifies that the appropriate message was received, a signed receipt can be generated and sent to the guard for filtering and then forwarded to the originator. In place of return receipts, servers capable of providing automatic tracking capabilities can be used to confirm document receipt.

Remote access capabilities pose a risk as a backdoor mechanism to gain access into a network. Therefore, for this scenario, the guard security mechanism would be most effective if coupled with a firewall. A firewall will protect the LAN from Internet or modem attacks by blocking direct access. Besides maintaining network access controls, the firewall will also maintain extensive audit records detailing successful and unsuccessful attempts to access the system. Once connected and authenticated, a dial-in user then has the same Internet services as local users. Internet connectivity is an inherent risk because it opens up channels of additional risk when connecting secret networks to unclassified networks. Therefore, a guard must be able to recognize Web-based protocols (i.e., HTTP) to mitigate risk for access into the networks.

Another important means of communicating for business is real-time messaging. Therefore, guards should be able to support real-time and instant messaging. When communicating by real-time messaging, messages should be ensured against corruption, tampering, recording, and nonplayback.

## **6.3.8 Technology Gaps**

### **6.3.8.1 High Volume of Binary Data**

Some applications require that information be passed in a binary representation. Examples of these applications are voice, imagery, and video. Binary data is more difficult to perform content checking on and to pass through filter rules. Guard technology needs to become faster to allow

large amounts of binary files and streaming binary information to pass through the high-assurance mechanisms to which other information is subject.

### **6.3.8.2 Quality of Service**

Quality of service (QoS) is being deployed in networks to support real-time applications, such as voice, video, and for other applications that might have strict latency requirements. Several different approaches exist for supporting QoS in IP networks. Although multiple approaches exist for providing QoS in an IP network, the guard that is implemented must support the QoS strategy for the organization.

Guards must support QoS mechanisms provided by the network. All incoming traffic is passed through the guard. If the QoS mechanism is not supported by the guard, end-to-end QoS that is required by the application cannot be supported.

### **6.3.8.3 High Speed Across Optical and Other Networks**

Most guards are designed to work in IP networks. However, many different types of networks could make use of guard technology, including all optical networks and asynchronous transfer mode (ATM) networks. These networks typically operate at speeds in excess of those of IP networks. In addition to adding the proper interface to the guard, the filtering mechanisms within the guard must be capable of the speeds on the optical network. Furthermore, optical and ATM networks are very sensitive to delays. If the guard is incapable of supporting the bandwidth requirements of a connection, communications through the guard may be degraded to a point where further connections cannot be accepted.

### **6.3.8.4 HyperText Markup Language Browsing**

Today's network environment uses HTML traffic for a variety of applications. Having a guard that supported HTML browsing for Internet or internal HTML would greatly increase the functionality of organizations.

To support HTML, a guard would have to allow requests (i.e., domain name server [DNS] queries, requests for Web pages) to pass through the guard. When the response returns, the guard must intercept the message and perform its checking before it is allowed to pass back to the user. All this must happen in real time to allow for human interaction and viewing behind the guard.

## References

1. Reserved.
2. CERT® Coordination Center. 17 July 2000 [www.cert.org](http://www.cert.org).
3. Software Engineering Management Practices. Carnegie Mellon Software Engineering Institute. 18 July 2000. 12 June 2000 <http://www.sei.cmu.edu/managing/managing.html>.
4. Trusted Product Evaluation Program. 12 June 2000. <http://www.radium.ncsc.mil/tpep/tpep.html>.
5. Lashley Brian and Andrzej Tarski. SSL <http://welcome.to/ssl>.
6. Federal Information Processing Standards Publications (FIPS) Pub 180. Secure Hash Standard 17 Apr 96 <http://www.itl.nist.gov/fipspubs/by-num.htm>.
7. Federal Information Processing Standards Publications (FIPS) 185. Escrowed Encryption Standard. 09 Feb 94 <http://www.itl.nist.gov/fipspubs/by-num.htm>.
8. Postal, J. and J. Reynolds. “File Transfer Protocol (FTP)”. RFC 959, ISI, 1985 October. <http://www.ietf.org/rfc/rfc0959.txt?number=959>.

## Additional References

- a. Computer Advisory Incident Capability. Department of Energy. 6 June 2000, <http://ciac.llnl.gov/ciac/bulletins/I-005c.shtml>. Enter at <http://ciac.llnl.gov>, then navigate to: <<http://ciac.llnl.gov/ciac/bulletins/I-005c.shtml>>.
- b. Digital Signature Trust Co. 3 July 2000. <http://www.digsigtrust.com/>.
- c. Reserved.
- d. National Institute of Standards and Technology (NIST) FIPS 186. FACT SHEET ON DIGITAL SIGNATURE STANDARD. Online posting May 1994. 3 July 2000 [http://www.nist.gov/public\\_affairs/releases/digsigst.htm](http://www.nist.gov/public_affairs/releases/digsigst.htm).
- e. NetworkWorldFusion News. 20 June 2000. <http://www.nwfusion.com/news/tech/0906tech.html>.
- f. Stronghold Webserver Administration Guide Chapter 6 SSL Authentication and Encryption. 22 June 2000 [http://mclean2.his.com/docs/Administration\\_Guide/SSL.html](http://mclean2.his.com/docs/Administration_Guide/SSL.html).
- g. Stronghold Webserver Administration Guide Chapter 6 SSL Authentication and Encryption. 22 June 2000 <http://developer.netscape.com/docs/manuals/security/ssl/contents.htm>.
- h. The Source of JAVA™ Technology. Smart Card Overview. 5 July 2000. <http://www.java.sun.com/products/javacard/smartcards.html>.
- i. Smart Card Basics.com. 5 July 2000 <<http://www.smartcardbasics.com/security.html>>.



**UNCLASSIFIED**

Guards

IATF Release 3.1—September 2002

- j. Hulme, George V. “Secure Document Delivery Gains Favor.” *InformationWeek*. 17 July, 2000.

## 6.4 Network Monitoring Within Enclave Boundaries and External Connections

A fundamental tenet of the defense-in-depth strategy is to prevent cyber attacks from penetrating networks and to detect and to respond effectively to mitigate the effects of attacks that do. As discussed above, an integral aspect of the defense-in-depth strategy embraced by this Framework is enclave boundary protection, which often takes the form of firewalls and virtual private networks (VPN). While these technologies offer perimeter and access controls, “authorized” internal and remote users can attempt probing, misuse, and malicious activities within an enclave. Firewalls do not monitor authorized users’ actions, nor do they address internal (insider) threats. Firewalls also must allow some degree of access, which may open the door for external vulnerability probing and the potential for attacks.

Detect and respond capabilities are complex structures that run the gamut of intrusion and attack detection, characterization, and response. The various detection aspects of detect and respond are actually measurement services. Intrusion detection, network scanning, and the like are measurement functions that determine the effectiveness of the deployed protection systems and procedures on a continuous or periodic basis. In themselves, detection capabilities are not protection measures. The respond aspect can initiate changes to existing protection systems (e.g., configuration changes in a firewall to block an attacker’s Internet Protocol [IP] address) or deploy additional protection measures (e.g., placement of another firewall appliance). The local environments (within enclaves) are the logical location for network-based sensors. This section addresses sensors that operate in near real time. Specific network monitoring technologies addressed in the Framework are shown in Figure 6.4-1. Section 6.5, Network Scanners Within Enclave Boundaries, addresses sensors that typically operate off-line. Section 7.2, Host-Based Detect and Respond Capabilities Within Computing Environments, provides similar guidance for host-based sensors.

Local environments have the option to implement as much or as little above the sensors as they believe is prudent, obtaining services and support from the infrastructure as necessary. Section 8.2 of the Framework provides an in-depth discussion of the various detect and respond processes and functions in the context of a supporting information assurance (IA) infrastructure capability. It also offers guidance on technologies for processes beyond the sensors,

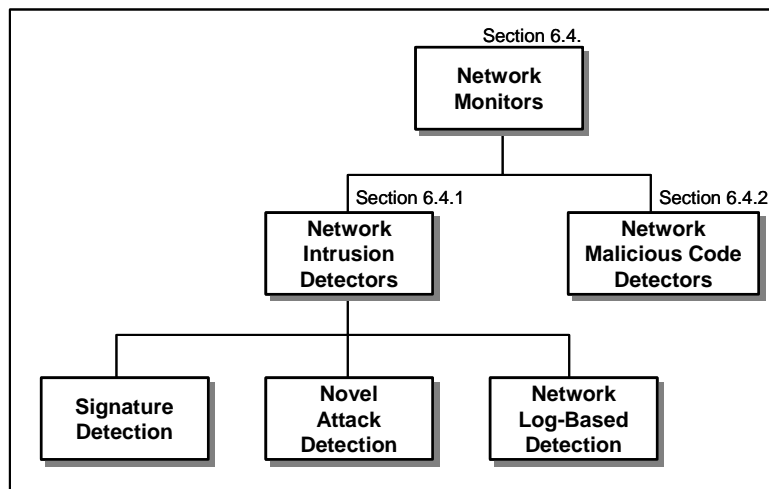

**Figure 6.4-1. Breakdown of Network Monitor Technologies**

iatf\_6\_4\_1\_0001

but recognizes that these processes may be implemented at any level in a network hierarchy, including a local enclave environment.

Network monitors, including network intrusion detection and network malicious code detection technology areas, are covered in this section. The section provides an overview of each relevant technology, general considerations for their use, the rationale for selecting available features, deployment considerations, and a perspective on how these technologies are typically bundled into products. The section concludes with sources for additional information and a list of the references used in developing this guidance.

## 6.4.1 Network Intrusion Detection

The goal of an intrusion detection system (IDS) is to identify and potentially stop unauthorized use, misuse, and abuse of computer systems by both internal network users and external attackers in near real time. Because this section of the Framework addresses network-based monitoring, these discussions center on operations using network information. As discussed in Section 7.2, Host-Based Detect and Respond Capabilities Within Computing Environments, similar structures and technologies are also available for performing comparable functions using host-based information.

### 6.4.1.1 Technology Overview

Normally, a dedicated computer is deployed for each network IDS on each network or network segment being monitored. A network interface card (NIC) is placed into promiscuous mode, enabling the IDS software to watch all traffic passing from computer to computer on that particular network. The IDS software looks for signs of abuse (e.g., malformed packets, incorrect source or destination addresses, and particular key words).

A network-based IDS bases its attack detection on a comparison of the parameters of the user's session and the user's commands with a rules-base of techniques used by attackers to penetrate a system. These techniques, referred to as "attack signatures," are what network-based IDSs look for in the behavior of network traffic. An attack signature can be any pattern or sequence of patterns that constitutes a known security violation. The patterns are monitored on the network data. The level of sophistication of an intrusion can range from a single event, events that occur over time, and sequential events that together constitute an intrusion.

## Detection Approaches

There are three basic technology approaches for performing network intrusion detection:

- **Signature detection approach** typically incorporates search engines that seek to identify known intrusion or attack signatures.
- **Novel attack detection** is based on identifying abnormal network behavior that could be indicative of an intrusion.

- **Network log-based detection** monitors for attacks using audit logs of network components.

**Signature Detection Approach.** This approach utilizes traffic analysis to compare session data with a known database of popular attack signatures. These IDSs act like a “sniffer” of network traffic on the network, caching network traffic for analysis. Typically, they do not introduce path delays while they are processing traffic and therefore do not impact network or application performance. Vendors refer to this operation as “real time.” Northcutt offers the perspective that “one of the great marketing lies in intrusion detection is ‘real time.’ What marketers mean by real time is that intrusion detection analysts are supposed to respond to beeps and alarms.” [“Network Intrusion Detection An Analyst’s Handbook,” by Stephen Northcutt, New Riders Publishing, 1999]

This technology examines the traffic against a predefined set of rules or attack signatures, typically using one of these techniques:

- **Pattern expression or bytecode matching.** The ability to determine regular behavior patterns to distinguish abnormal patterns, as well as determine if the traffic being monitored matches a predefined attack signature.
- **Frequency or threshold crossing.** The ability to establish a predefined threshold; if the threshold is exceeded, an intrusion is assumed.

There are two basic signature-based options: one, referred to as a “static signature IDS,” which uses a built-in attack signature base and a second, “dynamic signature IDS,” which relies on signature information that can be loaded dynamically into the IDS. Some product vendors provide routine updates of attack signatures. Some IDS tools give the customer the capability to customize attack signatures.

**Novel Attack Detection.** This relatively new detection strategy monitors Transmission Control Protocol (TCP) Dump data and attempts to filter out activities that are considered normal behavior. The genesis for this approach was to implement a sensor that would allow an analyst to evaluate large quantities of network information and select anomalous behavior. Unlike signature detection techniques, in which the sensor has to have a priori knowledge of specific attack scripts, this technique relies on screening by an analyst and can detect a variety of probes and attacks that other detection approaches miss. Initial versions dealt with packet header information only. Later versions capture the full packet content.

**Network Log-Based Detection.** This detection technique focuses on the monitoring of audit logs from network devices. It has two major components. One is a catalog of audited events that are considered “bad” behavior. The catalog could include attack profiles, suspicious activity profiles, and activities defined as unacceptable. The second component is an audit trail analysis module. Audit trails come from a chronological record of activities on a system. The analysis module examines the monitored system’s audit trail for activity that matches activity in the catalog; when a match occurs, intrusive activity is assumed. Audit-based systems may also

provide the ability to identify and track additional activity by an individual who is suspected of intrusive behavior.

## **IDS Tuning Options**

Typically, an IDS provides capabilities for selecting which attacks are being monitored. Depending on the specific implementation of an IDS, it is often possible to select which attacks will be monitored, what the response will be for each detected intrusion, specific source and/or destination addresses (to be monitored or excluded), and characterizations of the class (indication of the importance or severity) of each alarm. This capability, to configure the monitoring screen, is critical to optimize the monitoring capability of an IDS. In this way, it is possible to focus the sensor on specific events of interest and the response that the IDS will have on detection of events.

## **Response Options**

While the sensors detect and collect information about intrusions, it is the analyst who interprets the results. Some network IDS technologies offer automated response features to various alarms. In addition to logging the session and reporting, as indicated below, some have the option to terminate the connection, shun an address that was the source of the detected intrusion, throttle the amount of traffic allowed through a port, or even close down a site's operation. In some cases, the IDS can accomplish these operations itself; in others, it works in conjunction with a network interface device (e.g., firewall, router, or gateway) to achieve the desired result.

## **Reporting Mechanisms**

When it detects a threat, a network IDS generally sends an alert to a centralized management console where alert information can be recorded and brought to the attention of an administrator. Some of the network IDS technologies offer additional reporting capabilities. Some can automatically send an e-mail message over the network to alert an operator to the alarm condition. Others can initiate a message to a pager.

### **6.4.1.2 General Considerations for Use**

Network IDS technologies are an important aspect of an enclave's defensive posture. Table 6.4-1 provides a synopsis of advantages and disadvantages of using network-based IDS technology.

**Table 6.4-1. Network-Based IDS Considerations**

Advantages	Disadvantages
<p>Provides real-time measure of the adequacy of an infrastructure's network protection measures.</p> <p>Network-level sensors can monitor and detect network attacks (e.g., SYN flood and packet storm attacks).</p> <p>The insertion of a network-level sensor does not affect existing data sources from a performance and reliability standpoint.</p> <p>Well-placed network sensors are designed to provide an integrated, enterprise wide view, at the management console, of any large-scale attack.</p> <p>Operator expertise and training only required for the single network IDS platform.</p>	<p>Some network-based systems can infer from network traffic what is happening on hosts, yet they cannot tell the outcome of the commands executed on the host.</p> <p>Network-based monitoring and intrusion detection becomes more difficult on modern switched networks. Switched networks establish a network segment for each host; therefore, network-based sensors are reduced to monitoring a single host. Network switches that support a monitoring or scanning port can at least partially mitigate this issue.</p> <p>Network-based sensors cannot scan protocols or content if network traffic is encrypted.</p> <p>Must be used on each network segment because they are unable to see across routers and switches.</p> <p>Current network-based monitoring technologies cannot handle high-speed networks.</p>

The network-based IDS is typically deployed in the middle of a communications path between client and server and has access to data at all layers of communication. This process allows this type of sensor to do extensive analysis for attack detection and provide detection in near real time. Since a network IDS runs on an independent computer, there is no impact on the performance of other network resources.

Today, network traffic is often encrypted through mechanisms such as VPNs. A network IDS simply watches information traversing a network and is typically not capable of decrypting the packets. In these cases, the encryption blinds the IDS to any attacks that may occur. This type of sensor relies on passive protocol analysis causing it to “fail open.” This leaves the network available and vulnerable and leaves the IDS itself open to potential compromise.

Throughput is another concern. If only one network IDS computer was to monitor an entire network, that one computer would have to be capable of scanning every single network packet. At modest throughput levels (e.g., 50 Mb/s), most network IDSs can keep pace with the incoming stream of data. However, as network bandwidth increases and network loads reach higher rates (100 Mbps and beyond), one or even several network IDS computers may not be able to keep up with the flow of traffic.

### 6.4.1.3 Important Features

When selecting a network IDS, there are a number of features that should be considered. This section identifies these important features. The section that follows discusses rationales for the selection of these features.

## UNCLASSIFIED

Network Monitoring Within Enclave Boundaries and External Connections  
IATF Release 3.1—September 2002

### *Detection*

- Detection approach used by the network IDS.
- Does it perform packet fragmentation/reassembly?
- Which threshold adjustments can be made to the IDS?

### *Signatures*

- Number of events/signatures that can be stored.
- How often the signatures can be updated.
- Is the update static (manual) or dynamic (automated)?
- Are user-defined attack signatures allowed; if so, are the scripting tools easy to use?

### *Operations*

- Can it protect itself from unauthorized modifications?
- Does it recover from system crashes?

### *Response Options*

- Does it offer provisions for reconfiguring firewalls?
- Does it have session closing and reset capabilities?
- Does it have address blocking (shunning) capabilities?
- Can it execute program scripts on alarm?

### *Reporting Options*

- Does it report in real time to a workstation?
- Can network and host-based IDSs report to the same analyst console?
- Is the reporting interval configurable?
- Can IDS notify personnel using e-mail or pagers?
- Is the amount/type of information reported to a management station configurable?

### *Performance*

- Network compatibility.
- Number of packets that can be processed over an interval (packet size/bandwidth).
- Rate of false positives (identification of a nonintrusive activity as intrusive).
- Rate of false negatives (failure to identify an intrusive activity).

### *Platform*

- Operating system.
- Type of platform required to host network IDS.
- Processing burden for anticipated network traffic load.

### *Console Considerations*

- **Operator Interface.** Type of command and monitoring provisions available to an operator.
- **Mark as Analyzed.** Ability to clear or mark selected alarms that have been reviewed
- **Drill Down.** Ability to provide additional information for selected events.
- **Correlation.** Tools to correlate events based on source, destination, type.
- **Report Generation.** Ability to generate reports upon event detection and as periodic summary reports.

## 6.4.1.4 Rationale for Selecting Features

Detect and respond capabilities exemplify the necessity of integrating operations and personnel considerations with the selection of technology solutions, consistent with the overall defense-in-depth philosophy. As indicated earlier, network monitoring does not itself offer protection from intrusions or attacks. It should really be considered instrumentation that monitors (and “measures”) the effectiveness of a network’s existing protection structures. It is up to operators (personnel and operations) to interpret the outputs of the IDS and initiate an appropriate response. If full-time operators<sup>1</sup> are not available to interpret and formulate responses based on the IDS outputs, then IDS implementations will not typically add real value. In this case, it is likely that IDS deployments should not be considered. Otherwise, when selecting features for an IDS, there are a number of factors to be considered, based on how the IDS is intended to be used, whether full- or part-time operators will be available, and the skills of the operators to interpret the results.

### **Detection**

The type of detection mechanism is one primary consideration when selecting a network IDS technology. Another important consideration is the anticipated skills of the attacker. Signature-based detection, which is the traditional method used in network IDS technologies, typically lacks the ability to detect new (or modified) versions of attack strings. While many intrusions (typical of novices) use standard attack sequences (often downloaded from hacker bulletin boards), an accomplished adversary will have the capability to create new attacks or modify old attacks and thus thwart traditional signature detection mechanisms. Anomaly and misuse detection approaches have greater flexibility for identifying new or modified attacks (since they monitor network usage or behavior). But they are more complex to operate and not necessarily as responsive to traditional attack strings. These are also the only mechanisms currently available to monitor actions of otherwise authorized users for inadvertent or intentional misuse.

---

<sup>1</sup> Ideally operators should be available on a 24x7 basis. The number of operators will depend on the traffic loads and anticipated numbers of incidents. It is not uncommon to experience hundreds of thousands of intrusion alerts per day, and each must be investigated to determine which, if any, are serious threats.



## UNCLASSIFIED

Network Monitoring Within Enclave Boundaries and External Connections  
IATF Release 3.1—September 2002

The ability of the various detection schemes to correctly identify intrusions is a fundamental consideration. The rate of false positives (alerts resulting from normal traffic) and false negatives (failure to identify a real intrusion attempt) should be considered. While the technologies are continually being refined for improved performance, there are inherent features that may limit performance (e.g., anomaly detectors have been known to generate significantly higher false positive indications).

As always, any decision is based on level of risk, anticipated performance, cost (for purchase, deployment, and operation), and operational impact. The Framework recommends consideration for deployment of multiple attack detection schemes, ideally from different vendor sources. In this way, there is a greater likelihood of detection by at least one of the mechanisms deployed.

### Signatures

If a signature-based IDS is selected, it is desirable to have as many signatures as possible used for detection. However, there is usually an inverse relationship among the number of signatures, the response time for possible detection. The amount of traffic that can be monitored is also typically reduced when a large signature set is employed. Since the lists of possible attacks change frequently, it is strongly recommended that the IDS be capable of dynamically loading signatures. It is usually operationally more feasible and efficient if the downloading is handled on an enterprise (or at least site) basis. Most vendors that offer dynamic loading of signatures provide periodic updates to their signature base. While the update periods differ among vendors, a good rule of thumb is the more often the better. If operators have the skills to create custom signatures, then having the ability to support user-defined attacks is also desirable, particularly if custom attacks are found in one of your sites.

### Operations

It is desirable for the IDS to be easily configurable according to the security policies of the information system that is being monitored. Consideration should also be given to the IDS's ability to adapt to changes in system and user behavior over time (e.g., new applications being installed, users changing from one activity to another, or new resources becoming available that cause changes in system resource usage patterns).

By their nature, IDS sensors are located where intrusions are anticipated. Thus, it is important that an adversary not be capable of modifying the IDS to render it ineffective. It is desirable that the IDS be able to perform self-monitoring, detect unauthorized modifications, and notify an attendant console. To simplify recovery of operations after an intrusion, it is also desirable that the IDS be able to recover from system crashes, either accidental or due to malicious activity, and upon startup, be able to recover its previous state and resume its operation unaffected.

### Response Options

Many available solutions offer automated response options that seem on the surface to be very desirable. They imply that little or no human interaction is involved, as the devices can provide

an immediate response. There are serious pitfalls to consider, however, before these options are deployed. First, it is not uncommon for a network IDS to find thousands (and possibly hundreds of thousands) of events daily, depending on where it is employed, characteristics of the normal network traffic load, and many other factors. Often, the number of false positives may be high, giving rise to frequent unwarranted indications of intrusions. Automated responses that terminate connections, shun addresses, throttle traffic, or actually shut down a facility can often cause severe denial-of-service (DOS) threats to the network. It is strongly recommended that automated options not be used if there is a concern that they may cause DOS on the networks they are trying to defend.

## **Reporting Options**

Most network-based IDSs report alarms to an operator console. (See discussion of console features, below.) The desirable level and frequency of reporting is based primarily on the availability and skills of the operators. Some network IDS technologies offer the option of paging or sending e-mail messages to notify personnel of alarms. While these sound desirable, they have the potential to give rise to operational issues. With an IDS detecting thousands of alarms a day, these features have the potential for overloading e-mail servers (creating a DOS threat themselves) or paging operators extremely frequently at all times of the day and night. Most often, these features are not recommended.

## **Performance**

Network IDS performance varies due to the speed of the network, the amount of traffic, the number of nodes being protected, the number of attack signatures employed, and the power of the platform on which the IDS resides. IDSs may be overtaxed on busy networks. However, multiple IDSs can be placed on a given segment to subdivide host protection, thereby increasing performance and overall protection. For instance, high-speed networks employing asynchronous transfer mode (ATM), which uses packet fragmentation to improve efficiency over high-bandwidth communications, do pose problems in terms of performance and response.

## **Platform**

A major issue for the selection of a network-based IDS is the type of computer skills (e.g., UNIX, NT) required for operators. Operators will likely need these skills to perform installation, configuration, adjustment, and maintenance. Since a network-based IDS usually is located on its own platform, the platform will have to be acquired and maintained, so it may be useful to select a technology that functions on the types of platforms used within the enterprise.

## **Console Considerations**

As discussed in Section 8.2 of the Framework, the primary function of the console is to serve as an aid in the characterization and analysis of the many alarms that will be identified. Operators will have to not only identify alarms that were unwarranted, those that do not offer serious risks

to the network, and those that do, but also gain a first-order understanding of the source and impact of possible attacks.

**Operator Interface.** The type of interface that is operationally desired tends to be driven directly by operator preference. Novices typically prefer a graphical user interface (GUI) with intuitive operations, pull-down screens, and substantial aids available. Skilled operators may prefer command string operations, tailored screen options, and options for operator customization. It is best if operators can get a hands-on trial evaluation of the console capabilities prior to final selection.

**Mark as Analyzed.** Operators will typically be faced with large numbers of alarms that have to be analyzed and cleared. A capability that is usually critical is the ability to selectively keep track of alarms that have been reviewed.

**Drill Down.** Many network IDS consoles display a high level characterization of events in order to display the large number of alarms that are detected. Operators will usually have to access additional details about each alarm to be able to characterize it properly. It is very desirable for the console to be able to provide the additional levels of information when requested by the operator. As with the operator interface, the types of information desired will typically depend on the skills of the operators.

**Correlation.** In the same vein as drill-down features, operators will require tools for correlating events (e.g., based on source, destination, type of alarms, and events) in order to identify and properly characterize intrusions and attacks. This is particularly necessary in situations where the incidents are distributed in time or location. The ability of the console to integrate the reporting of various network-based and host-based IDSs and other relevant events is a strong plus, if the operators will use the additional information. Again, as with the operator interface, the types of tools desired will typically depend on the skills of the operators.

**Report Generation.** The type of reporting options will depend predominantly on the type of information operators will want to perform their characterization, and the organization's need for reporting to higher levels (e.g., periodic summary reports). It is always desirable to select a console that is capable of generating and disseminating reports with little extra effort beyond the hour-to-hour and minute-to-minute responsibilities that the operators will have otherwise.

### 6.4.1.5 Considerations for Deployment

Network architectures present another major challenge for a network IDS. Network switches, which segregate network traffic into specific individual "subnets," reduce network loads across an organization by implementing a form of "need to know" policy among connected computers. Network switches only allow traffic to enter a subnet if it is meant for a computer within that subnet; similarly, they only allow packets out of a subnet that are destined for a computer outside its particular realm.

A network IDS can see only traffic available on the segments on which it is installed. As long as the network IDS is placed on critical segments, it will be able to measure the effectiveness of the

security protection mechanisms for the most critical systems and applications. Within an enclave environment, there are a number of possible locations to consider in deploying a network IDS, as depicted in Figure 6.4-2. The challenge is to identify where the traffic of most interest (i.e., that most likely to be used as an attack channel) can be monitored.

The external gateways are an obvious candidate in that they allow the IDS to see all of the traffic destined for the enclave. If IDSs are placed outside the firewall, they have access to the raw wide area network (WAN) traffic (e.g., Internet) without the benefit of filtering by the firewall. If network encryption is used on that traffic, this will offer little if any value. Placing the IDS inside the firewall resolves network encryption issues but will not give any indication of the effectiveness of the firewall operation. Placing sensors at both points and correlating the output of the alarm causing packets that are detected outside but blocked by the firewall could provide this additional perspective. Note that these locations provide monitoring either for external traffic that is destined for the enclave or for internal traffic that is destined for the WAN. IDSs in these locations do not monitor traffic that is only internal to the enclave.

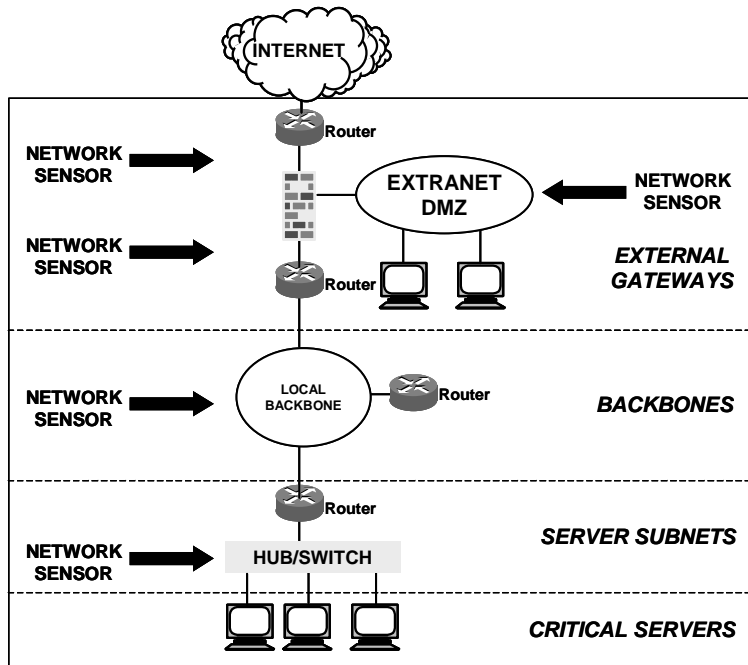

**Figure 6.4-2. Network IDS Deployment Options**

If an extranet (or what may be referred to as a demilitarized zone, or DMZ) is deployed, an IDS on that segment of the network could offer monitoring of traffic from outsiders to assets structured for an isolated segment of the enclave.

The network backbone represents another deployment option. This option does provide access to internal traffic on the backbone. However, at this point in the network, consideration should be given to the traffic speeds and switching technologies employed on those backbones. In some cases (e.g., ATM, Fiber Distributed-Data Interface [FDDI]) the switching technologies and transmission speeds make currently available IDS technologies impractical.

A final placement option is on server subnets. This is typically a good option if hubs are used, so that all traffic on the subnet is available at each hub port. If switches are used rather than hubs, this is still a good option if there is a spanning port available (that allows access to all traffic). If not, the IDS will not have access to all the traffic through the switch and will be ineffective unless deployed between a host and a switch (or “onto” a host).

There is always a trade-off between the possible deployment locations and the number of IDSs to be deployed. Factors to consider include the workload of the operators needed to analyze and characterize the alarms that each IDS generates; the complexity of correlating the alarms that multiple monitors will generate for the same event; and the costs associated with purchase, installation, operation, and maintenance of the various deployment options.

### **6.4.1.6 Considerations for Operation**

As discussed above, most IDS technologies provide the capability to tune the sensor to improve its performance for specific deployments. When an IDS is first deployed, it is prudent to operate the technology for some period depending on the complexity of the deployment to complete this tuning. This provides a means for determining that the IDS is capable of detecting alarms, and that the IDS is installed on the network as intended (by verifying network addresses that are monitored and the direction of traffic).

Tuning enables the IDS to preclude the detection of authorized traffic patterns that might otherwise cause false positive alarm indications. There are two fundamental approaches for tuning. The first approach is to have knowledge a priori of the traffic sources that could trigger false alarms. This could include the addresses of servers (that expect significant traffic), network management station locations (that normally sweep the network), and computers that are remotely located. The IDS can then be configured (tuned) to preclude these from causing an alarm.

While it is desirable to have such information ahead of time, it is often not available. The other approach is to run the IDS and have it find alarms. As alarms are detected, an analyst determines if indeed they reflect an intrusion or a false positive based on normal operation. This form of “discovery” also gives operators an opportunity to become familiar with the technology before it goes on-line operationally.

Tuning should not be thought of as strictly an installation process. This process should be done on a regular basis to refine detection mechanisms and focus them on real intrusions and to reduce false positives throughout IDS operation.

## **6.4.2 Malicious Code (or Virus) Detectors**

Malicious code can attack authorized local area network (LAN) users, administrators, and individual workstation/personal computer users in numerous ways, such as modifying data in transit, replaying (inserting data), exploiting data execution, inserting and exploiting malicious code, exploiting protocols or infrastructure bugs, and modifying malicious software during production and/or distribution.

Over the past decade, malicious code (also commonly referred to as computer viruses<sup>2</sup>) has gone from an academic curiosity to a persistent, worldwide problem. Viruses can be written for and spread on virtually any computing platform. Typically, viruses are written to affect client personal computers. However, if the personal computer is connected to other machines on a LAN, it is possible for the virus to invade these machines as well. See Section 6.6, Malicious Code Protection, for detailed descriptions of the various types of malicious code, potential malicious code attacks and countermeasures, and requirements for malicious code detection products and technologies.

### 6.4.2.1 Technology Overview

Malicious code scanning technologies prevent and/or remove most types of malicious code. The use of malicious code scanning products with current virus definitions is crucial in preventing and/or detecting attacks by all types of malicious code.

There are several basic categories of antivirus (AV) technologies:

- **Preinfection Prevention Products.** A first level of defense against malicious code, used before a system has been attacked
- **Infection Prevention Products.** Used to stop replication processes and prevent malicious code from initially infecting the system.
- **Short-Term Infection Detection Products.** Used to detect an infection very soon after the infection has occurred
- **Long-Term Infection Detection Products.** Used to identify specific malicious code on a system that has already been infected for some time, usually removing the malicious code and returning the system to its prior functionality.

See Section 6.6.5.2, Viruses and E-Mail, for a more detailed description of the types of malicious code detection technologies.

### 6.4.2.2 Important Features

When selecting AV technologies, there are a number of features that should be considered. This section identifies important features for selection. The section that follows discusses the rationale for the selection of these features. Additional factors to consider when selecting a malicious code detection product can be found in Section 6.6.6, Selection Criteria.

---

<sup>2</sup> Throughout the remainder of this section, the term *virus* will be used to encompass the broader class of malicious code and delivery mechanisms.

## Detection Capabilities

- Data integrity checks.
- Perimeter-level scanning for e-mail and Web traffic.
- Does tool exploit malicious mobile code?
- Real-time virus scanning.
- On-demand virus scanning.
- Network packet monitoring.
- Different strains of polymorphic viruses.
- Viruses residing in encrypted messages, compressed files.
- Viruses in different languages (e.g., JAVA, ActiveX, and Visual Basic).
- Trojan horses and worms.

## Updates

- Can tool upgrade an existing version?
- Are regular updates available?
- Frequency of update releases.
- Response mechanisms.
- Quarantine at the server level.
- Quarantine at the console level.
- Supply network-based responders.
- Send alerts to network or system administrators.
- Send alerts (in the case of e-mail borne viruses) to sender and receiver(s).

## Platform Considerations

- What platforms does the tool run on?
- Does tool allow cross-platform support?

### 6.4.2.3 Rationale for Selecting Features

When selecting AV products, two important guidelines must be followed. The “best” product may not be good enough by itself. Also, since data security products operate in different ways, one product may be more useful than another in different situations. The following categories provide a rationale for evaluating the features of specific technology offerings. Rating each product according to these categories will allow an organization to choose the best malicious code detection product for its needs.

## Detection Capabilities

As discussed in Section 6.6.5.2, Viruses and E-mail, most computer-virus scanners use pattern-matching algorithms that can scan for many different signatures at the same time. Malicious code detection technologies have to include scanning capabilities that detect known and unknown worms and Trojan horses. Most AV products search hard disks for viruses, detect and

## UNCLASSIFIED

Network Monitoring Within Enclave Boundaries and External Connections  
IATF Release 3.1—September 2002

remove any that are found, and include an auto-update feature that enables the program to download profiles of new viruses so that it will have the profiles necessary for scanning. The virus signatures these programs recognize are quite short: typically, 16 to 30 bytes out of the several thousand that make up a complete virus. It is more efficient to recognize a small fragment than to verify the presence of an entire virus, and a single signature may be common to many different viruses.

## Updates

Maintaining an effective defense against virus and hostile code threats involves far more than the ability to produce perfect detection rates at a given point in time. With an average of nearly 300 new viruses discovered each month, the actual detection rate of AV software can decline rapidly if not kept current. This AV protection should be updated regularly. As new viruses are discovered, corresponding cures are developed to update protections. These updates should not be ignored. AV systems should do these updates automatically, reliably, and through a centrally controlled management Framework. To stay current, these scanning programs must be updated when new virus strains are found and AV codes are written. Most computer-virus scanners use pattern-matching algorithms that can scan for many different signatures at the same time. This is why enterprise-class AV solutions must be able to offer timely and efficient upgrades and updates across all client and server platforms.

Often, in large enterprise environments, a typical acquisition and deployment strategy is to deploy one brand of AV software at end-user workstations and a different vendor's product in the e-mail, file, and application server environments. This broadens the spectrum of coverage because in any given instance, one vendor is typically ahead of another in releasing the latest round of virus signature discoveries.

## Response Mechanisms

Once malicious code has been detected, it must be removed. One technique is simply to erase the infected program, but this is a harsh method of elimination. Most AV programs attempt to repair infected files rather than destroy them. If a virus-specific scanning program detects an infected file, it can usually follow a detailed prescription, supplied by its programmers, for deleting virus code and reassembling a working copy of the original file. There are also generic techniques that work well for known and unknown viruses. One method is to gather a mathematical fingerprint for each program on the system. If a program subsequently becomes infected, this method can reconstitute a copy of the original. Most tools perform scanning for viruses, but all do not detect and remove Trojan horses, worms, and malicious mobile code upon all levels of entry. Most currently available AV tools do not have the same capabilities when responding across a network. Additional countermeasures related to malicious code can be found in Section 6.6.4, Potential Countermeasures.



## Platform Considerations

The computers to run this software must meet the hardware and software requirements specified by the manufacturer. The malicious code protection software should function properly and perform its duties without failing or interfering with other applications running on the same system.

### 6.4.2.4 Considerations for Deployment

Defense in depth dictates that any virus protection must be implemented across the enterprise. This means installing and managing AV software on every system. Some advocate installing AV software only on edge devices, such as servers, firewalls, and gateways. But defense against viruses is only as good as its weakest link, and if one system can be compromised, then the entire enterprise is at risk.

Centralized management for the AV capabilities with a common set of policies is strongly recommended. Though some vendor offerings cater to end-users who are being held responsible for following security mandates, this can lead to more and varied security holes. What most often happens is that end users (or many of them), when their sessions are interrupted with a pop-up screen telling them their files are about to be scanned or that they are about to receive an AV update, tend to override the update manually, because it is distracting.

### 6.4.2.5 Considerations for Operation

Most AV technologies provide a means for sending responses or alerts at the server level, and some at the console level. It is always desirable to notify anyone that may have been infected that malicious code has been detected. This should include system and network administrators. If malicious code is encountered in e-mail transactions, it is desirable to notify the sender and recipient. If it is found on a file system that knows the file owner, he or she should be notified. In general, anyone that could be notified should be.

## 6.4.3 Discussion of Typical Bundling of Capabilities

At one point, network monitors were offered as stand-alone devices. Vendors may prefer to offer these technologies as appliances, sold with what is otherwise a commercial off-the-shelf (COTS) computer system, at an inflated price. There are also a number of offerings that combine these monitors with firewalls, routers, vulnerability scanners, and the like as a means for vendors to leverage existing market positions to gain market share in related areas. Another trend that is becoming popular is for larger vendors to offer integrated architecture approaches, in which they combine a number of related technologies as a bundled offering. Vendors tend to prefer custom rather than standard interfaces to preclude the merging of other vendor offerings. This offers a so-called “complete solution”; however, it tends to lock the buyer into one

particular product suite. While this often sounds attractive, it is often valuable to be able to integrate various technologies together in order to take advantage of the detection capabilities available from the different implementations.

There is a natural linkage of these monitoring technologies with Enterprise Security Management (ESM) systems, and vendors have been talking about the integration for some time. However, there is little evidence to suggest that this integration will be realized in the foreseeable future.

## 6.4.4 Beyond Technology Solutions

While the focus of the Information Assurance Technical Framework (IATF) is on technology solutions, there are important operational aspects of effective network monitoring that are also critical to an effective IA solution. The Framework recommends the following guidance:

### *Operational Planning*

- Develop intrusion detection and AV-related requirements as an integral part of the enterprise security policy.
- Assess the ability of system administration personnel to perform intrusion detection and related vulnerability scanning.
- Consult with experienced intrusion detection and vulnerability scanning personnel regarding the best approach.
- Consult with the appropriate legal council regarding affected personnel rights and procedures, as discussed below.
- Provide for adequate technical and legal training of all involved personnel.
- Acquire software and expertise from a high-integrity vendor.
- Perform network monitoring consistent with the enterprise security policy.
- Tightly couple vulnerability scanning and intrusion detection activities.

### *Intrusion Detection Activities*

- Look for intrusion evidence based on found vulnerabilities; use intrusion evidence to find and correct vulnerabilities.
- Provide and monitor bogus sites/services/information. Possibly monitor intrusions through known vulnerabilities to satisfy prosecution requirements in conjunction with the appropriate legal authorities.
- Perform intrusion responses that are approved by the appropriate authority.

### ***Network Malicious Code Detection Activities***

- Select and deploy virus scanning capabilities that are consistent with the location, functions, and capabilities.
- Acquire or download the appropriate AV software from a high-integrity source, and acquire any necessary hardware (such as an ancillary firewall dedicated to virus scanning of incoming or outgoing traffic).
- Institute enterprise wide AV training and procedures.
- Scan consistently based on time and/or events.
- Follow up on all indications of potential contamination (as defined in the security policy and AV procedures for the enterprise).
- Update AV software and hardware as appropriate (e.g., consistent with new releases of AV software and specific experiences throughout the enterprise).

### ***General Activities***

- Archive (within any legal constraints) audit and intrusion information, and correlate with vulnerability scan information.
- Keep authorities apprised of all activities, ensuring that any legal rights are not violated.
- Regularly repeat steps, as appropriate.

### ***Privacy Concerns***

Organizations may own the intellectual property of employees and may also legally restrict computer activities to those approved by management. A common practice is to present this warning to all computer users as part of the normal login message. This does not mean that ALL managers in an enterprise own ALL of the transactions of ALL of the employees. Especially unclear is how to handle the conflict that arises between privacy and monitoring. Use of IDSs and system monitoring tools requires caution. Sniffers that search for key words in messages (e.g., “attack,” “weakness,” or “confidentiality”) as a standard set of “watchwords” may find them used in an appropriate manner depending on the type of correspondence. Audit trail reports may contain full command strings (including parameters). Knowing that an employee is sending several messages to a particular department (e.g., Human Resources) may be an infringement on his or her privacy. It is important to refer privacy concerns to the appropriate legal and policy organizations for the enterprise prior to deployment and use of these technologies.

## **6.4.5 For More Information**

The source materials used in the preparation of this section provide an excellent base of knowledge of relevant technologies from which to draw. A number of additional sources of

information exist. This section of the Framework focuses on on-line sources since they tend to offer up-to-date information. These include the following.

### 6.4.5.1 IATF Executive Summaries

An important segment of the IATF is a series of “Executive Summaries” that are intended to provide summary implementation guidance for specific situations. These offer important perspectives on the application of specific technologies to realistic operational environments. While these are still being formulated, they will be posted on the IATF Web site <http://www.iatf.net> as they become available. [1]

### 6.4.5.2 Protection Profiles

The National Security Telecommunications and Information Systems Security Policy (NSTISSP) No. 11 provides the national policy that governs the acquisition of IA and IA-enabled information technology products for national security telecommunications and information systems. This policy mandates that, effective January 2001, preference be given to products that are in compliance with one of the following:

- International Common Criteria for Information Security Technology Evaluation Mutual Recognition Arrangement.
- National Security Agency (NSA)/National Institute of Standards and Technology (NIST) National Information Assurance Partnership (NIAP).
- NIST Federal Information Processing Standard (FIPS) validation program.

After January 2002, this requirement is mandated. Department of Defense (DoD) Chief Information Officer (CIO) Guidance and Policy Memorandum No. 6-8510, Guidance and Policy for Department of Defense Global Information Grid Information Assurance references this same NSTISSP No. 11 as an acquisition policy for the Department.

- The International Common Criteria and NIAP initiatives base product evaluations on Common Criteria Protection Profiles.
- NSA and NIST are working to develop a comprehensive set of protection profiles for use by these initiatives. An overview of these initiatives, copies of the Protection Profiles, and status of various products that have been evaluated are available at the NIST Web site <http://niap.nist.gov/> [2]

### 6.4.5.3 Independent Third Party Reviewers of Relevant Vendor Technologies

- ICISA Net Security Page [www.icsa.net](http://www.icsa.net)

## UNCLASSIFIED

Network Monitoring Within Enclave Boundaries and External Connections  
IATF Release 3.1—September 2002

- Talisker's Intrusion Detection Systems [www.networkintrusion.co.uk/](http://www.networkintrusion.co.uk/)
- Network Computing—The Technology Solution Center  
[www.nwc.com/1023/1023f12.html](http://www.nwc.com/1023/1023f12.html)
- Paper on CMDS Enterprise 4.02 <http://www.Intrusion.com/Products/enterprise.shtml>  
(ODS Networks has changed its name to Intrusion.com)
- PC Week On-Line [www.zdnet.com/pcweek/reviews/0810/10sec.html](http://www.zdnet.com/pcweek/reviews/0810/10sec.html)

### 6.4.5.4 Overview of Relevant Research Activities

- Coast Home page – Purdue University [www.cs.purdue.edu/coast](http://www.cs.purdue.edu/coast)
- UC Davis <http://seclab.cs.ucdavis.edu/>

### 6.4.5.5 Overview of Selected Network Monitor Vendor Technologies

- Axent Technologies <http://www.axent.com/>
- cai.net <http://www.cai.net/>
- Cisco Connection Online [www.cisco.com](http://www.cisco.com)
- CyberSafe Corporation <http://www.cybersafe.com>
- Internet Security Systems [www.iss.net](http://www.iss.net)
- Network ICE [www.networkice.com](http://www.networkice.com)

## UNCLASSIFIED

Network Monitoring Within Enclave Boundaries and External Connections  
IATF Release 3.1—September 2002

### References

1. Information Assurance Technical Framework (IATF) <http://www.iatf.net>
2. National Institute of Standards and Technology <http://niap.nist.gov/>.

### Additional References

- a. Amoroso, Edward, Intrusion Detection. Intrusion.Net Books. 1999.
- b. Escamilla, Terry. Intrusion Detection, Network Security Beyond the Firewall. Wiley Computer publishing. 1998.
- c. Northcutt, Stephen. Network Intrusion Detection, An Analyst's Handbook. New Riders Publishing. 1999.
- d. Snapp, Steven R., et al. A System for Distributed intrusion Detection. IEEE CH2961-1/91/0000/0170. 1999
- e. Balasubramanian, J. S., et al. An Architecture for Intrusion Detection Using Autonomous Agents. COAST Technical Report. 11 June 1998.
- f. AXENT Technologies, Inc. Intruder Alert 3.5 IDS Review Guide, May 2000.
- g. AXENT Technologies, Inc. Everything You Need to Know About Intrusion Detection, 1999.
- h. Schneider, Sondra, et al. Life After IDS. Information Security Magazine. Volume 2, Number 9. September 1999.
- i. Graham, Robert. New Security Trends for Open Networks. SC Magazine. October 1999.
- j. SC Magazine. Intrusion Detection. June 2000.
- k. Information Assurance Technology Analysis Center (IATAC). Tools Report on Intrusion Detection. Defense Technical Information Center. December 1999.
- l. Maes, V. How I Chose an IDS. Information Security Magazine. Volume 2, Number 9. September 1999.
- m. Concurrent Technologies Corporation. Attack Sensing, Warning, and Response (ASW&R) Trade Study Report Intrusion Detection System. Report No. 0017-UU-TE-000621. April 14, 2000.
- n. Information Assurance Technology Analysis Center (IATAC). Tools Report on Vulnerability Analysis Information. Defense Technical Information Center. March 15, 2000.
- o. Ulsch, Macdonnell and Joseph Judge. Bitter-Suite Security. Information Security Magazine. Volume 2, Number 1. January 1999.

## UNCLASSIFIED

Network Monitoring Within Enclave Boundaries and External Connections  
IATF Release 3.1—September 2002

- p. Concurrent Technologies Corporation. Attack Sensing, Warning, and Response (ASW&R) Baseline Tool Assessment Task Anti-Virus Trade Study Report. Report No. 0017-UU-TE-000623. April 13, 2000.
- q. Department of Defense (DoD) Chief Information Officer (CIO) Guidance and Policy Memorandum No. 6-8510, Guidance and Policy for Department of Defense Global Information Grid Information Assurance.
- r. National Security Telecommunications and Information Systems Security Policy (NSTISSP) No. 11. National Policy Governing the Acquisition of Information Assurance (IA) and IA-Enabled Information Technology (IT) Products. January 2000.

## 6.5 Network Scanners Within Enclave Boundaries

As discussed in Section 6.4, Network Monitoring Within Enclave Boundaries and External Connections, on-line network monitoring technologies provide a critical layer of defense within enclave boundary protection. In addition to the network monitoring technologies, another class of technologies, referred to as network scanners, can also be deployed to improve overall security posture. The framework makes a distinction between these scanners and network monitoring devices. Monitors typically operate in near real time and have network traffic (or related characteristics) as their focus. Monitors tend to measure the effectiveness of the network's protection services that are subject to attempted exploitation. This is somewhat of an "after the fact" measure, not a preventive measure. Scanners, on the other hand, are preventive measures. Typically, they operate periodically (or on demand) and examine systems for vulnerabilities that an adversary could exploit, measuring the effectiveness of the system's infrastructure protection.

The local environment is the logical place for addressing these network assessment technologies. Scanning can be performed at the network boundary or at the host level. This segment of the Information Assurance Technical Framework (IATF) specifically considers network vulnerability scanner and War Dialer technologies that are germane to the enclave environment. Please refer to Section 7.2, Host-Based Detect and Respond Capabilities Within Computing Environments, for guidance on the use of similar technologies that are more suitable for deployment at the host level.

Unlike the near-real-time network monitoring technologies addressed in Section 6.4, Network Monitoring Within Enclave Boundaries and External Connections, network assessment technologies are typically executed in a periodic or on-demand manner, providing perspectives on the posture of a local environment. Section 8.2, Detect and Respond as a Supporting Element, of the framework provides a perspective on an overall detect and response infrastructure; however, because these assessments typically focus on the local level, they tend not to interact with or be particularly relevant to a broader network infrastructure.

### 6.5.1 Network Vulnerability Scanners

Periodic or on-demand network assessment tools are adept at finding security holes at boundary-point devices or on network hosts within an enclave environment, hopefully before an attacker does. They accomplish this effort by discovering known vulnerabilities in host or network system components and improper configurations visible from the network that create the potential for unauthorized access or exploitation or are counter to enterprise policies.



## 6.5.1.1 Technology Overview

Vulnerability analysis tools help automate the identification of vulnerabilities in a network or system. Network-based vulnerability scanners take an inventory of all devices and components within the network infrastructure. These scanners operate over a network “against” target nodes by probing and examining the network components and hosts to identify vulnerabilities that are typically visible to their network connection. They seek to identify network services that allow uncontrolled access, contain buffer control vulnerabilities, violate possible trust privileges, and contain weaknesses in network component (e.g., router, firewall, and Web server) configurations.

A scanner probes for weaknesses by comparing data about a network configuration with its database of known vulnerabilities. Network components, the network configuration, and the various versions of the software controlling the network are examined and compared with this database. Network vulnerability scanners fall within one or more of the following classes.

### Simple Vulnerability Identification and Analysis

A number of tools have been developed that perform relatively limited security checks. These tools may automate the process of scanning Transmission Control Protocol/Internet Protocol (TCP/IP) ports on target hosts, attempting to connect to ports running services with well-known vulnerabilities and recording the response. They also may perform secure configuration checks for specific system features. The user interface of these tools is likely to be command-line based, and the reporting may include limited analysis and recommendations. The tools are likely to be freeware.

### Comprehensive Vulnerability Identification and Analysis

More sophisticated vulnerability and analysis tools have been developed that are fairly comprehensive in terms of the scope of vulnerabilities addressed, the degree of analysis performed, and the extent of recommendations made to mitigate potential security risks. Many of these tools also provide a user-friendly graphical user interface (GUI).

### Password Crackers

Password cracker tools attempt to match encrypted forms of a dictionary list of possible passwords with encrypted passwords in a password file. This is possible because the algorithm used to encrypt an operating system’s passwords is public knowledge. An attacker or insider would run these tools after successfully gaining access to the system in order to acquire a higher privilege level, such as root. These tools allow operators to verify compliance with password selection policies. Many tools from the previous category have integrated password-cracking modules.

## Risk Analysis Tools

Risk analysis tools typically provide a framework for conducting a risk analysis but do not actually automate the vulnerability identification process. These tools may include large databases of potential threats and vulnerabilities along with a mechanism to determine, based on user input (typically query/response scripts), cost-effective solutions to mitigate risks. The vulnerabilities identified using a vulnerability analysis tool may be input into a risk analysis tool to assist in determining the overall risk to the system, or conversely, vulnerabilities predicted by a risk analysis tool can be specifically targeted for confirmation using vulnerability scanning tools.

### 6.5.1.2 General Considerations for Use

Network vulnerability scanners operate across the network to identify weaknesses in a connected system's security scheme, exploitation of which would negatively affect the confidentiality, integrity, or availability of the system or its information. These scanners are easy to install and can run a wide variety of attacks on a network to determine the network's resilience to each attack. However, a scanner only takes a snapshot of the network and does not operate in real time, often requiring post-capture analysis to understand and implement any mitigation approaches that may be required. Typically, local area network (LAN) administrators do not use scanners on a day-to-day basis.

Scanners work either by examining attributes of objects or by emulating an attacker. To act as a hacker, a scanner can execute a variety of attack scripts. Because these can look (and act) like real attacks, it is important to consider what and when scans are performed. Otherwise, it is possible that the scanner could have as much impact on the network as an actual incident. Coordination with network operations staff is critical, particularly in environments that implement real-time intrusion detection techniques. However, another use of such scanners is a "live" test and readiness evaluation of intrusion detection and incident response processes and procedures for an enterprise environment.

The vulnerability scanner will detect only objects it is configured to scan. If the scanner is not configured and set up properly, there may be vulnerabilities that are not identified. Therefore, using these tools may be of less value than performing no scans at all, because it may offer a false sense of the adequacy of the network's resiliency to attacks.

### 6.5.1.3 Important Features

When considering the selection of a network-based vulnerability scanner, a number of features should be considered. This section identifies important features for selection. The section that follows discusses the rationale for the selection of these features.

### ***Scanning Capabilities***

- Does the tool offer an ability to add custom scanning routines to look for site- or technology-specific weaknesses of concern?

### ***Response Mechanisms***

- Automatic shutoff of vulnerable ports of entry.

### ***User Interfaces***

- Does the tool have a GUI for number entry, dialing status, and call results?
- Can reports be viewed in real time?

### ***Reporting Capabilities***

- Does the tool offer automatic alerting when new non-network ports are detected?
- Are all system answers logged in a database or file?
- Is there an updated database of network numbers with which to compare newly identified numbers?
- Does the database automatically combine logged information and place it in a report format?
- Does the tool provide suggested mitigation approaches for discovered vulnerabilities?

### ***Platform Compatibility***

- What are the platforms (operating systems) on which the tool will run?
- Does it use executables?
- Does it support scripts or macros?

## **6.5.1.4 Rationale for Selecting Features**

The type and level of detail of information provided varies greatly among tools. Although some can identify only a minimal set of vulnerabilities, others can perform a greater degree of analysis and provide detailed recommended mitigation approaches. The selected scanner technologies should cover the full range of vulnerabilities for the given environment and system platforms. In addition, the technologies should offer a comprehensive library of vulnerabilities, periodically updated by the vendor. Capabilities including grouping of nodes into scan groups and customized scan options may be valuable for larger environments.

Some scanner technologies offer features that are useful depending on the training and skill levels of the operators that will be using them. Depending on the planned usage of the scanner

and the skills of the operators available, it is often desirable to select technologies that can be tuned to ignore some false positives. It is also desirable to select features that enable the scanner to be tuned for important application environments, such as database environments, Web server environments, file server environments, firewalls, etc., since such profiles may differ based on the functions provided.

### ***Scanning Capabilities***

The type and level of detail of information provided varies greatly among tools. Although some can identify only a minimal set of vulnerabilities, others can perform a greater degree of analysis and provide detailed recommended mitigation approaches.

### ***Response Mechanisms***

Assessment tools will continue to evolve in usability, with some vendors offering click-and-fix solutions. The assessment software flags vulnerabilities in terms of the risk posed to the network and the ease of the fix. Some technologies can generate trouble tickets to trigger a manual response. They may offer an ability to change policies in firewalls and other enclave boundary defense mechanisms. Some identify patches that should be installed. Some offer to obtain and install patches. Although installing patches is feasible, allowing the security administrator the ability to undertake these tasks and the difficulty of undoing configuration changes should leave customers wary of this function. Such features should be considered in light of an environment's existing configuration management policies and procedures.

### ***User Interfaces***

Most scanners enable the operator to configure what network elements are to be scanned and when the scans are to occur. Typically, scanners are preconfigured with lists of vulnerabilities and can operate without customization. Some technologies allow operators to customize the vulnerabilities the scanner will investigate. Usually the results are sorted into a file that can be accessed upon demand to review the results. More recently developed tools provide user-friendly front ends and sophisticated reporting capabilities.

### ***Reporting Capabilities***

Old products inundated customers with phonebook-size reports on all the various vulnerabilities that the network faced. New products have database interfaces that prioritize vulnerabilities and allow network managers to deal with the network's problems in a logical manner. Many generate reports that are Web-enabled with hot-links and other "labor savers."

### ***Platform Compatibility***

The computers to run this software must meet the hardware and software requirements specified by the manufacturer. The vulnerability scanner software should function properly and perform its duties without failing.

**Source**

- Has the tool been developed by the Government (or under government sponsorship); if so, is it reserved; can your organization obtain authorization for its use?
- Is the tool available from a reputable vendor?
- Is the tool in the public domain (e.g., freeware from the Internet); if so, is source code available?

## 6.5.2 War Dialers

Firewalls and other enclave boundary protection devices can create a level of defense against network attacks that adversaries have to defeat. However, as the trend continues toward borderless networks, machines with attached modems are often scattered throughout organizations. When modems are installed on telephone lines connected to the data network, firewalls are no longer the only access port to the network, and thus cannot detect or control ALL of the data traffic that is traveling in or out of the network. The result is that “back doors” are created that offer alternative, unprotected portals for adversaries to exploit, as depicted in Figure 6.5-1. Analysts estimate that the bulk of damaging hacks on corporate networks come over modem connections that are not secure. One technology, called War Dialers, is a specific form of network vulnerability scanner.

### 6.5.2.1 Technology Overview

Most commonly, War Dialers are associated with hackers. Most hackers target organizations because they rarely control the dial-in ports as strictly as a firewall. One way of combating intrusions by hackers is to use the same type of scanning tool as a defensive mechanism.

A War Dialer consists of software that dials a specific range of telephone numbers looking for modems that provide a login prompt. The tools, at a minimum, record the modem numbers and login screen, but can also be configured to attempt brute force, dictionary-based login attempts. Visibility into telephone networks is provided by identifying modem, fax, or voice tones and characterizing security behaviors. This process allows identification of network vulnerabilities.

War Dialers call a given list or range of telephone numbers and record those that answer with handshake tones. Those handshake tones may be characterized as entry points to computer or telecommunications systems. Some of these programs have become quite sophisticated, and can now detect modem, fax, or private branch exchange (PBX) tones and log each one separately. A block of specified numbers is attempted and any modems found in that block are noted.

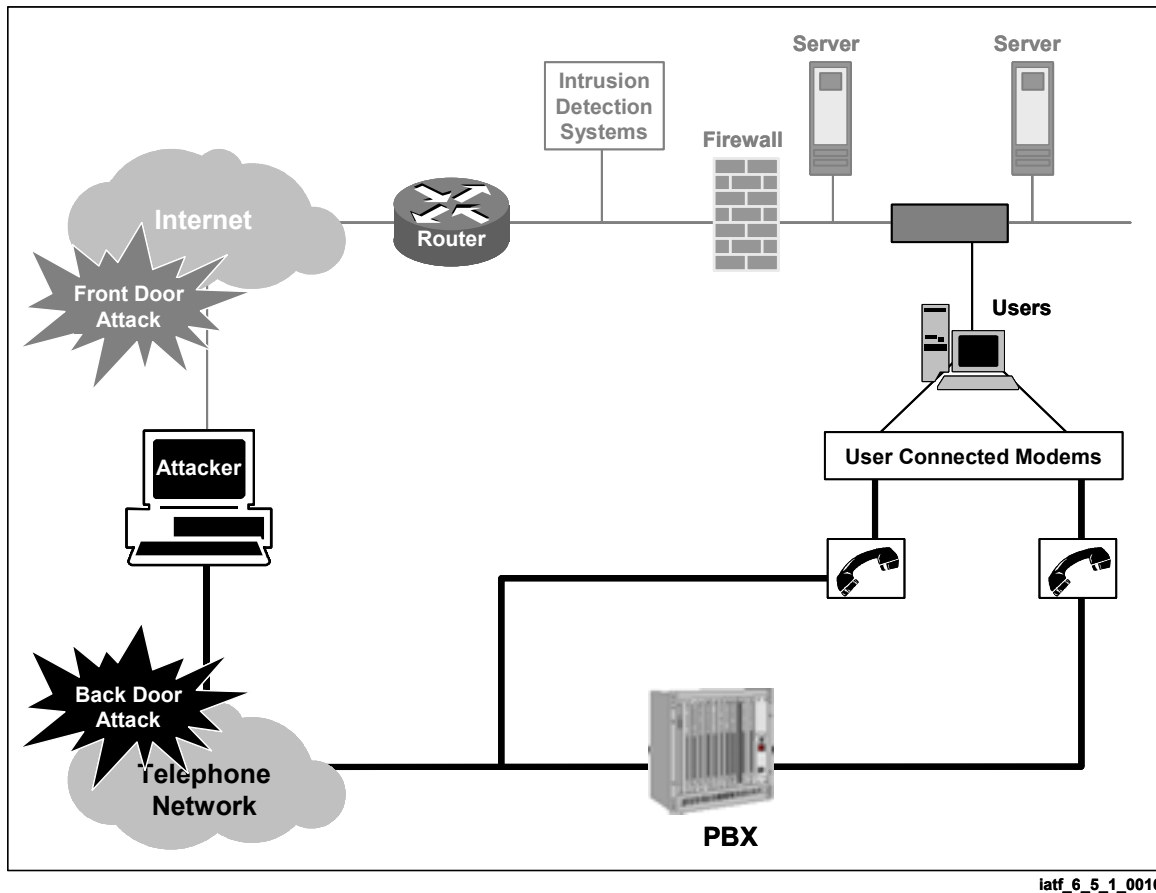

iatf\_6\_5\_1\_0016

Figure 6.5-1. Back-Door Attacks Through Telephone Networks

### 6.5.2.2 General Considerations for Use

Remote access to most organizations' information systems is usually performed through ordinary telephone lines. The lack of visibility into telephone networks makes it possible for any user to connect to an entire private data network via a modem. These telephone lines must be thought of as ports of entry for possible network attacks and intrusions. When an enclave does not deploy protection mechanisms that effectively secure or monitor telephone networks, intruders can gain access to proprietary information; existing security systems remain blind to unauthorized activity. War Dialers are an effective way to identify unsecured modems. Along with a strong modem policy describing the need for modem registration and PBX controls, War Dialer scanning can help an organization defend itself against such dangers. Use of this type of technology can help an enterprise to identify those vulnerable back doors before an attack occurs. Once identified, those back doors can be closed or some type of security plan created to preclude use of that particular point of entry.

### 6.5.2.3 Important Features

When selecting a War Dialer technology, a number of features should be considered. This section identifies important features for selection. The section that follows discusses the rationale for the selection of these features.

#### *Scanning Capabilities*

- Identification of every dial-up system.
- Facsimile machine detection.
- Multi-modem scanning.
- Brute force username and/or password guessing (code cracking).
- Support terminal emulation to allow tool to enable access to mainframe computers.
- Built-in knowledge of various dial-in authentication technologies.

#### *Response Mechanisms*

- Automatic shutoff of vulnerable ports of entry (interface to telephone network).

#### *User Interfaces*

- Does the tool have a GUI for number entry, dialing status, and call results?
- Can reports be viewed in real time?

#### *Reporting Capabilities*

- Automatic alerting when new non-network ports are detected.
- Are all system answers logged in a database or file?
- Is there an updated database of network numbers with which to compare newly identified numbers?
- Does the database automatically combine logged information and place it in a report format?

#### *Platform Compatibility*

- What platforms (operating systems) will the tool run on?
- Does it use executables?
- Does it support scripts or macros?

#### *Source*

- Has the tool been developed by the Government (or under government sponsorship); if so, is it reserved; can your organization obtain authorization for its use?

- Is the tool available from a reputable vendor?
- Is the tool in the public domain (e.g., freeware from the Internet); if so, is source code available?

### **6.5.2.4 Rationale for Selecting Features**

War Dialers identify known modems, modem banks, and communication servers; compare discovered modem configuration data against predefined modem configurations; and alert administration when a vulnerable port of entry has been detected. The major discriminator is how well each product performs these functions.

It is often difficult to determine the true nature of the features that are provided in a particular technology offering (beyond strict vendor claims). It is always advisable to seek test results of reputable, independent third-party laboratories. When these are available, they should be an important consideration in any technology selection. A number of organizations provide these types of results.

#### ***Scanning Capabilities***

It is important that the War Dialer be capable of uncovering and characterizing all back doors on the network, because each represents a potential unprotected portal for an adversary. Thus, beyond simply identifying when a modem responds to an incoming call on each telephone line specified, it is possible to uncover when computers serving as facsimile machines and modem banks are encountered. Further, the ability to emulate a terminal (to enable access to mainframe computers) and apply password cracking mechanisms provides valuable information regarding how susceptible the identified parts actually are, supporting efforts to prioritize those that require earlier resolution. The more extensive scanning capabilities a tool offers the more thorough and reliable report it can provide on the actual posture of the network.

#### ***Response Mechanisms***

For the most part, War Dialers report on back doors they have uncovered. However, technologies are available that can automatically shut off vulnerable ports of entry. Care should always be taken when selecting any automated response. In this case, shutting down a remote access port may have negative effects on operational capabilities.

#### ***User Interfaces***

Most scanners enable the operator to enter telephone numbers and provide dialing status and call results. Usually the results are stored in a file that can be accessed upon demand to review the results. Depending on the skills of the intended operator, it may be desirable to select a tool that offers a user-friendly interface. Recently developed tools provide a user-friendly user interface for number entry, dialing status, and call results.



### ***Reporting Capabilities***

Again, based on the intended manner in which the War Dialer is operated, it may be desirable to select features that provide automatic alerting when new non-network ports are detected. If reports of the results of War Dialer scans are required by the organization, consideration should be given to technologies that offer the capability for the database to automatically combine logged information and place it in a report format. If the enterprise allows selected remote access ports to remain operational, operators may be concerned primarily with new ports that were not reported previously. In this situation, consideration should be given to technologies that are able to update the database of network numbers with which to compare newly identified numbers.

It is important to ensure that the selected technology logs all system answers in a database or file. If the operator will be monitoring the results of the War Dialer assessment during its operation, it will be important to consider technologies where reports can be viewed in real time.

### ***Platform Compatibility***

The computers to run this software must meet the hardware and software requirements specified by the manufacturer. The malicious code protection software should function properly and perform its duties without failing.

### ***Source***

A number of War Dialers have been developed by the Government (or under government sponsorship). If one of these is selected, it may be reserved for use only by selected communities. In these situations, it is necessary to determine if your organization can obtain authorization for its use.

A wide array of War Dialers are available as freeware or shareware. These are regarded as hacker tools and are an open source via the Internet. Many commercial scanners dial only predetermined numbers in a telemarketing atmosphere. Commercial products are preferred because they tend to offer technical support mechanisms; typically, no reliable means exist for support for freeware and/or shareware. Overall, the functions are the same, but technical support, better reporting styles, and more attractive GUIs can be found with the commercial products offered today.

Care should be taken when using any software obtained from the public domain (e.g., freeware from the Internet). The software should be scanned carefully for potential malicious code. If source code is not available, the software's use is *NOT* recommended.

## **6.5.3 Considerations for Deployment**

The same considerations that apply to placement of network monitors, discussed in Section 6.4, Network Monitoring Within Enclave Boundaries and External Connections, are in general applicable in deploying network scanners. Network switches, which segregate network traffic

into specific individual “subnets,” reduce network loads across an organization by implementing a form of “need-to-know” policy among connected computers. Network switches allow traffic to enter a subnet only if it is meant for a computer within that subnet; similarly, packets are only allowed out of a subnet that are destined for a computer outside its particular realm.

Network scanners only can find vulnerabilities that they can see based on the segments on which they are installed. As long as the network scanner is placed on critical segments, it will be able to measure the effectiveness of the security protection mechanisms for the most critical systems and applications. Within an enclave environment, a number of possible locations should be considered in deploying a network scanner. The challenge is to identify the locations where the potential vulnerabilities are of most interest. This is often considered from the view of potential attacker sources that are of concern. For example, if the concern is for hackers from the Internet, the scanner should be structured to look at the network from that vantage point. If the concern is for insider threats, that vantage point should be considered. Because the scanners can operate on demand, they can be used in one location and then moved to another to determine the overall security posture of a network environment.

## 6.5.4 Considerations for Operation

Assessment frequency is a factor of how often network changes are made and the security policy for the enterprise. Depending on the organization, assessments may take place quarterly, monthly, weekly, or even daily. Some service providers offer scanning services on a subscription basis, ensuring that assessments occur regularly.

## 6.5.5 Discussion of Typical Bundling of Capabilities

At one point, network monitors were offered as stand-alone devices. Vendors may prefer to offer these technologies as appliances, sold with what is otherwise a commercial off-the-shelf (COTS) computer system, at an inflated price. A number of offerings combine these monitors with firewalls, routers, vulnerability scanners, and the like as a means for vendors to leverage existing market positions to gain market share in related areas. Another trend that is becoming popular is for larger vendors to offer integrated architecture approaches, in which they combine a number of related technologies as a bundled offering. Vendors tend to prefer custom rather than standard interfaces to preclude the merging of other vendor offerings. This offers a so-called “complete solution”; however, it tends to lock the buyer into one particular product suite. Although this often sounds attractive, it is valuable to be able to incorporate various technologies to take advantage of the detection capabilities available from the different implementations.

There is a natural linkage of these monitoring technologies with Enterprise Security Management (ESM) systems, and vendors have been discussing the integration for some time. However, there is little evidence to suggest that this integration will be realized in the foreseeable future.

## 6.5.6 Beyond Technology Solutions

Although the focus of the IATF is on technology solutions, operational aspects of effective network scanning are critical to an effective information assurance (IA) solution. Network scanning is the primary means of assessing the security of the network. The functions performed by the scanner should be tailored to the network configuration and environment, together with the applications performed by the protected network. The framework recommends the following guidance for network scanners:

- Develop network scanning requirements as an integral part of the enterprise security policy.
- Scan your network consistent with the guidance listed for intrusion detection and response, using the best available scanners.
- Assess the results in light of your security policy.
- Adjust and counter identified deficiencies relative to your policy. This may include patches, changes in configuration, changes in procedures, or better enforcement of procedures such as the use of good passwords that change frequently.
- Repeat the process regularly.

## 6.5.7 For More Information

The list of reference materials used in preparing this section provides an excellent base of knowledge from which to draw on relevant technologies. A number of additional sources of information exist. This section of the framework focuses on on-line sources because they tend to offer up-to-date information. These include the following.

### 6.5.7.1 IATF Executive Summaries

An important segment of the IATF is a series of “Executive Summaries” that provides summary implementation guidance for specific situations. These summaries offer important perspectives on the application of specific technologies to realistic operational environments. Although these are still being formulated, they will be posted on the IATF Web site [www.iatf.net](http://www.iatf.net) as they become available. [1]

### 6.5.7.2 Protection Profiles

The National Security Telecommunications and Information Systems Security Policy (NSTISSP) Number 11 provides the national policy that governs the acquisition of IA and IA-enabled information technology products for national security telecommunications and information systems. This policy mandates that, effective January 2001, preference be given to products that are in compliance with one of the following.

- International Common Criteria for Information Security Technology Evaluation Mutual Recognition Arrangement.
- National Security Agency/National Institute of Standards and Technology (NSA/NIST) National Information Assurance Partnership (NIAP).
- NIST Federal Information Processing Standard (FIPS) validation program.

After January 2002, this requirement is mandated. Department of Defense (DoD) Chief Information Officer (CIO) Guidance and Policy Memorandum No. 6-8510, Guidance and Policy for Department of Defense Global Information Grid Information Assurance references this same NSTISSP Number 11 as an acquisition policy for the Department.

The International Common Criteria and NIAP initiatives base product evaluations on Common Criteria Protection Profiles. NSA and NIST are developing a comprehensive set of protection profiles for use by these initiatives. An overview of these initiatives, copies of the Protection Profiles, and the status of various products that have been evaluated are available at the NIST Web site [http://niap.nist.gov/\[2\]](http://niap.nist.gov/[2])

### **6.5.7.3 Independent Third Party Reviewers of Relevant Vendor Technologies**

- ICSA Net Security Page [www.icsa.net](http://www.icsa.net)
- Talisker's Intrusion Detection Systems [www.networkintrusion.co.uk/](http://www.networkintrusion.co.uk/)
- Network Computing—The Technology Solution Center [www.nwc.com/1023/1023f12.html](http://www.nwc.com/1023/1023f12.html)
- Paper on CMDS Enterprise 4.02 [www.ods.com/downloads/docs/Cmds-us.pdf](http://www.ods.com/downloads/docs/Cmds-us.pdf) (ODS Networks has changed its name to Intrusion.com)
- PC Week On-Line [www.zdnet.com/pcweek/reviews/0810/10sec.html](http://www.zdnet.com/pcweek/reviews/0810/10sec.html)

### **6.5.7.4 Overview of Relevant Research Activities**

- Coast Home page—Purdue University [www.cs.purdue.edu/coast](http://www.cs.purdue.edu/coast)
- UC Davis [www.seclab.cs.ucdavis.edu/cidf](http://www.seclab.cs.ucdavis.edu/cidf)
- UC Davis [www.seclab.cs.ucdavis.edu](http://www.seclab.cs.ucdavis.edu)

### **6.5.7.5 Overview of Selected Network Scanner Vendor Technologies**

- Axent Technologies [www.axent.com](http://www.axent.com)
- cai.net <http://www.cai.net/>

## UNCLASSIFIED

Network Scanners Within Enclave Boundaries  
IATF Release 3.1—September 2002

- Cisco Connection Online [www.cisco.com](http://www.cisco.com)
- CyberSafe Corporation [www.cybersafe.com](http://www.cybersafe.com)
- Internet Security Systems [www.iss.net](http://www.iss.net)
- Network ICE [www.networkice.com](http://www.networkice.com)

### 6.5.7.6 Overview of Selected War Dialer Technologies

- VerTTeX Software [www.verttex.com](http://www.verttex.com)
- The Hackers Choice [www.infowar.co.uk/thc/toneloc](http://www.infowar.co.uk/thc/toneloc)
- AT&T Information Security Center [www.att.com/isc/docs/war\\_dialer\\_detection.pdf](http://www.att.com/isc/docs/war_dialer_detection.pdf)

## References

1. Information Assurance Technical Framework (IATF) <http://www.iatf.net>.
2. National Institute of Standards and Technology <http://niap.nist.gov/>.

## Additional References

- a. Amoroso, Edward, Intrusion Detection. Intrusion. Net Books. 1999.
- b. Escamilla, Terry. Intrusion Detection, Network Security Beyond the Firewall. Wiley Computer publishing. 1998.
- c. Northcutt, Stephen. Network Intrusion Detection, An Analyst's Handbook. New Riders Publishing. 1999.
- d. Concurrent Technologies Corporation. Attack Sensing, Warning, and Response (ASW&R) Baseline Tool Assessment Task War Dialer Trade Study Report. Report No. 0017-UU-TS-000480. March 23, 2000.
- e. King, Nathan A. Sweeping Changes for Modem Security. Information Security Magazine. Volume 3, Number 6. June 2000.
- f. Ulsch, Macdonnell and Joseph Judge. Bitter-Suite Security. Information Security Magazine. Volume 2, Number 1. January 1999.
- g. Department of Defense (DoD) Chief Information Officer (CIO) Guidance and Policy Memorandum No. 6-8510, Guidance and Policy for Department of Defense Global Information Grid Information Assurance.
- h. National Security Telecommunications and Information Systems Security Policy (NSTISSP) No. 11. National Policy Governing the Acquisition of Information Assurance (IA) and IA-Enabled Information Technology (IT) Products. January 2000.

**UNCLASSIFIED**

Network Scanners Within Enclave Boundaries  
IATF Release 3.1—September 2002

**This page intentionally left blank.**

## 6.6 Malicious Code Protection

The objective in this section of the framework is to elucidate the importance of defense from destructive malicious code. Information is provided regarding malicious code protection techniques and how malicious code infiltrates a system. Detection and recovery tactics are described as well as different types of malicious code scanners used to protect systems.

Malicious code protection allows authorized local area network (LAN) users, administrators, and individual workstation/personal computer users to safely conduct daily functions in a secure manner. Commonly, many people misuse the word virus assuming it means anything that infects their computer and causes damage. The correct term for this is really malicious code. A virus is simply a computer program created to infect other systems/programs with copies of itself. Worms are similar to viruses; however, they do not replicate and the intent is usually destruction. Logic bombs contain all types of malicious code and activate when certain conditions are met. Viruses, worms, and logic bombs can also be concealed within source code disguised as innocent programs like graphic displays and games. These apparently innocent programs are called Trojan horses. The relationship among these different types of malicious code is illustrated in Figure 6.6-1.

The quantity of new malicious code introduced into the computing environment has increased exponentially. This situation has occurred for several reasons. Computer users have become increasingly proficient and sophisticated, and software applications have become increasingly complex. Some brands of software are now widely used, thus their bugs and security loopholes are often known to intelligent users capable of writing destructive code. With the widespread use of personal computers that lack effective malicious code protection mechanisms, it is relatively easy for knowledgeable users to author malicious software and dupe unsuspecting users into copying or downloading it. In addition, since virus information and source code is readily available through the Internet and other sources, creating viruses has become a relatively simple task.

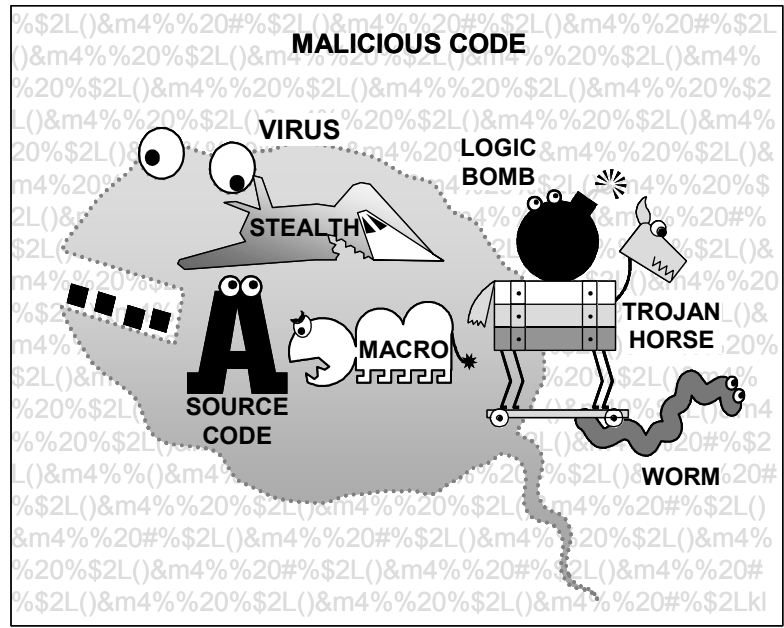

iatf\_6\_6\_1\_0018

**Figure 6.6-1. Malicious Code Relationship**



## 6.6.1 Target Environment

Malicious codes protection typically is provided at two places in the architecture: at the gateway and at workstations that access information services. Malicious code can infiltrate and destroy data through network connections if allowed beyond the gateway or through individual user workstations. Today, the majority of individual users keep all data files on networks or shared file systems instead of on diskettes. Therefore, the continual application of protection of network connections at the gateway is essential. Malicious code usually enters existing networks through the gateway by means of security loopholes or e-mail attachments. Its intent is to cripple the network and individual workstations. Malicious code can also attack the network through protocols, typically, File Transfer Protocol (FTP), Hypertext Transfer Protocol (HTTP), and Simple Mail Transfer Protocol (SMTP) (e-mail). The individual user workstation is then subsequently infected. In Figure 6.6-2 below, a simplified network is illustrated with several workstations connected to a single gateway, and through that, to the Internet. Although a single user can bring an infected disk to work, infecting his or her workstation and eventually the entire network, the majority of infections by malicious code result from file sharing across different protocols. Malicious codes attacking individual user workstations are primarily macro viruses and other less potentially destructive viruses. These viruses typically enter systems through e-mail attachments; however, their primary intent is not destruction.

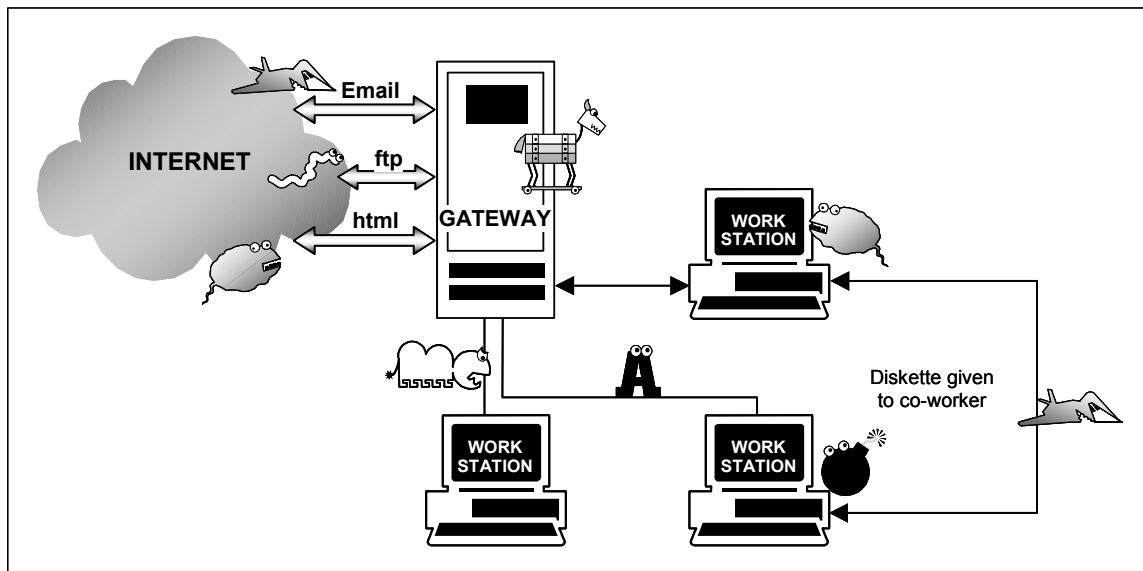

iatf\_6\_6\_2\_0017

Figure 6.6-2. Sources of Malicious Code Infections

## 6.6.2 Malicious Code Protection Requirements

### Malicious Code Detection System Requirements

The following have been identified as representative malicious code detection system requirements from a customer's perspective of needs.

The malicious code detection system shall—

- Allow access to all services available on the wide area networks (WAN) using any of the existing and emerging networking technologies and applications.
- Be able to locate the source and type of an infection, be able to react to such intrusions, and be able to fully reconstitute the system following damage caused by intrusions.
- Have minimal operational effect on the user.
- Have minimal operational effect on performance of the associated components.
- Have appropriate documentation for its use and upgradability and contain all currently available references and resources.
- Allow automatic malicious code prevention programs to run in the background.
- Allow a disaster recovery plan to recover data if necessary.
- Provide adequate scanning tools to be able to contain an identified virus by isolating affected systems and media.
- Have appropriate means to trace all incoming and outgoing data, including e-mail, FTP transactions, and Web information.
- Be able to, in the event the Internet is unavailable for any reason, still have access to virus updates from the manufacturer or vendor of the antivirus product.
- Monitor usage as required by the administrator.
- Scan for malicious software at the enclave boundary and at individual workstations.
- Log and analyze source-routed and other packets; react to or restrict malicious code attacks.
- Allow a rapid disconnect from the network in the event of a detected malicious code attack.

### Configuration/Management Requirements

The following have been identified as representative configuration and/or management requirements for malicious code detection systems.

The malicious code detection system shall—

- Be updated with regard to relevant security issues (malicious code detection, system vulnerability) so maximum protection is provided.
- Be capable of preventing worm programs from infecting networks by allowing the administrator to disable the network mail facility from transferring executable files.
- Be configured by the administrator to filter all incoming data, including e-mail, FTP transactions, and Web information, for all types of malicious code.
- Allow the administrator to automatically create policy for network usage that details what sort of computing activity will and will not be tolerated.
- Allow regular backups of all system data by the administrator.
- Provide adequate controls such as strong user authentication and access control mechanisms on network connections for the administrator.
- Be capable of setting additional passwords or authentication for select files and accounts accessed from network ports.
- Be capable of placing restrictions on types of commands used on networks and in select files.
- Deny access to system manager accounts from network ports, if possible.
- Monitor usage of the network during odd hours, if possible, and create a log of all activity for the system administrator.
- Provide no more than one administrator account (i.e., not give other users administrator privileges).

## 6.6.3 Potential Attack Mechanisms

Malicious code can attack authorized LAN users, administrators, and individual workstation/personal computer users in numerous ways, such as modifying data in transit, replaying (inserting previously collected data), exploiting data execution, inserting and exploiting malicious code, exploiting protocols or infrastructure bugs, and modifying malicious software during production and/or distribution. (See Sections 4.2.1.4.2, Network-Based Vulnerabilities and Active Attacks, and 4.2.1.4.4, Hardware/Software Distribution.)

### 6.6.3.1 Viruses and Worms

The operating system (OS) is software that controls all inputs and outputs to the system and manages the execution of programs. A virus or worm can infect the OS in two ways: by completely replacing one or more OS programs or by attaching itself to existing OS programs and altering functionality. Once a virus or worm has altered or changed OS functionality, it can

control many OS processes that are running. To avoid detection, the virus or worm usually creates several hidden files within the OS source code or in “unusable” sectors. Since infections in the OS are difficult to detect, they have deadly consequences on systems relying on the OS for basic functions.

## Macro Viruses

Application programs on a system provide users with significant functionality. A macro virus can easily infect many types of applications such as Microsoft Word and Excel. To infect the system, these macro viruses attach themselves to the application initialization sequence. When an application is executed, the virus’ instructions execute before control is given to the application. These macro viruses move from system to system through e-mail file sharing, demonstrations, data sharing, and disk sharing. Viruses that infect application programs are the most common and can lie dormant for a long time before activating. Meanwhile, the virus replicates itself, infecting more and more of the system.

### 6.6.3.2 Logic Bombs

After a logic bomb has been activated, it can maliciously attack a system in the following ways: halt machine, make garbled noise, alter video display, destroy data on disk, exploit hardware defects, cause disk failure, slow down or disable OS. It can also monitor failures by writing illegal values to control ports of video cards, cause keyboard failure, corrupt disks and release more logic bombs and/or viruses (indirect attacks). These attacks make logic bombs an extremely destructive type of malicious code.

### 6.6.3.3 Trojan Horses

Trojan horses are another threat to computer systems. Trojan horses can be in the guise of anything a user might find desirable, such as a free game, mp3 song, or other application. They are typically downloaded via HTTP or FTP. Once these programs are executed, a virus, worm, or other type of malicious code hidden in the Trojan horse program is released to attack the individual user workstation and subsequently a network.

### 6.6.3.4 Network Attacks

With the number of networks increasing exponentially, potential threats to these networks are numerous and devastating. The most common attack is to deny service by generating large volumes of Transmission Control Protocol/Internet Protocol (TCP/IP) traffic. The target site is rendered “unavailable” to the rest of the Internet community. The next level of denial-of-service (DOS) attacks is the distributed DOS-attack where several machines on the target site are exploited. Distributed DOS attacks are the most effective and insidious because they generate more traffic from other sources, making it much harder to identify the attacker’s source, and subsequently more difficult to resolve. An example of a distributed DOS attack was the attack by “coolio” in February 2000, which caused the crash of numerous Web sites in the United

States, including Ebay, CNN, Yahoo!, and E\*Trade. This attack involved sending Internet Control Message Protocol (ICMP) echo request datagrams (ping packets) to the broadcast address of networks using a faked or “spoofed” IP address of the host to be attacked. The IP host responds to these ICMP echo requests on either the nominal address or the broadcast address of its interfaces. When the broadcast address of a network was pinged, all active hosts on that network responded, and for any one request, there were many replies. This amplification makes distributed DOS attacks very powerful and causes large networks to crash.

### **6.6.3.5 Trapdoors**

Trapdoors provide easy access for system administrators and authorized personnel to a system or a system’s resources. Individuals can usually gain this access without a password. When these trapdoors are exploited, however, threats to a computer system are created. Authorized or unauthorized users with knowledge of trapdoors, can plant various types of malicious code into sensitive areas of a system. Therefore, the first layer of defense, prevention of malicious code, is bypassed, and the system must rely on detection and removal mechanisms to rid the system of the newly introduced malicious code.

### **6.6.3.6 Insider Attacks**

Traditionally, insiders are a primary threat to computer systems. Insiders have legitimate access to the system and usually have specific goals and objectives. They can affect availability of system resources by overloading processing or storage capacity, or by causing the system to crash. Insiders can plant Trojan horses in sensitive data files, which attack the integrity of the entire system. Insiders can also exploit bugs in the OS by planting logic bombs or by causing systems to crash. All of these attacks by insiders are difficult to prevent, as legitimate access is essential to all users for crucial daily functions.

### **6.6.3.7 Connection/Password Sniffing**

Other threats to the integrity of a system include connection and password “sniffing.” A “sniffer” is malicious software or hardware that monitors all network traffic, unlike a standard network station that only monitors network traffic sent explicitly to it. Software sniffers can be a real threat to a network because they are “invisible” and easily fit on all workstations and servers. The specific threat presented by sniffers is their ability to catch all network traffic, including passwords or other sensitive information sent in plain text. An added threat to network security is that detecting sniffers on other machines is extremely difficult.

## **6.6.4 Potential Countermeasures**

This section is subdivided into six types of countermeasures that can be applied to prevent and/or remove malicious code: malicious code scanning products, electronic security (access constraint countermeasures), trapdoor access constraints, network security, connection and password sniffing countermeasures, and physical security.

### 6.6.4.1 Malicious Code Scanning Products

Malicious code scanning products are used to prevent and/or remove most types of malicious code, including viruses, worms, logic bombs, and Trojan horses, from a system. The use of malicious code scanning products with current virus definitions is crucial in preventing and/or detecting attacks by all types of malicious code.

### 6.6.4.2 Electronic Security

Electronic security typically refers to access constraint mechanisms used to prevent malicious code from being introduced into a system, intentionally or unintentionally, by authorized users. Unintentional system infiltration is the primary reason to implement access constraint mechanisms. If a set number of attempts to input a password correctly is exceeded, the system administrator must be contacted immediately. The system or system administrator should ensure that users change their passwords frequently and should not allow the use of dictionary words. This prevents easy decryption of passwords. Checksums can also be used; however, they only pertain to some strains of viruses. All of these electronic security measures protect against employees' intentionally or inadvertently deploying malicious code into a system or network.

The following are additional access constraint countermeasure requirements:

- **Provide data separation.** For data that is allowed access to the protected network workstation, steps should be taken to constrain the portion of the system that can be affected in case of a malicious code attack.
- **Employ application-level access control.** Access restrictions may also be implemented within a workstation or at various points within a LAN to provide additional layers and granularity of protection against authorized and unauthorized malicious code attacks.

### 6.6.4.3 Trapdoor Access/Distribution

To protect against unauthorized use of trapdoors to introduce malicious code, reliable companies should be used when considering software and hardware purchases. When inputting data, only use reliable inputting individuals and use monitoring devices to monitor them. Reliable system administrators should remove passwords immediately after an employee leaves a company. All of these prevention techniques are crucial to prevent malicious code from infiltrating systems through trapdoors.

### 6.6.4.4 Network Security

A boundary protection mechanism at the gateway must be used within a network. The requirements for a boundary protection mechanism are mentioned in the following sections of the Information Assurance Technical Framework (IATF): Section 6.1, Firewalls, Section 6.3,

Guards, and Section 8.2, Intrusion Detection. The requirements in these sections describe a boundary protection mechanism for network security.

There are also several ways to protect a network against distributed DOS attacks by malicious code. Secure hosts on the network by replacing “rlogin” and “rexec” commands with “ssh” or other encrypted commands. Also, disallow IP spoofing to keep hosts from pretending to be others. Do not allow ICMP to broadcast and multicast addresses from outside the network. These few preventive methods will help prevent distributed DOS attacks.

### **6.6.4.5 Connection and Password Sniffing Countermeasures**

Although sniffing of Internet traffic is difficult to stop, there are several ways to defend a system and make sniffing difficult. First, use an encryption mechanism (e.g., Secure Sockets Layer [SSL]) to allow encryption of message transmissions across Internet protocols whenever possible. Also, encrypt e-mail through the use of Pretty Good Privacy (PGP) and Secure Multi-Purpose Internet Mail Extensions (S/MIME). Although e-mail is sent encrypted, when e-mail is read it must be unencrypted. If mail programs allow attachments to automatically run, malicious code can still infect a system. The malicious code will be encrypted with the rest of the message and activate when you read the decrypted message. Also, implement “ssh” or other encrypted commands instead of insecure remote login. To stop password sniffers, use secure remote access and smart cards to keep passwords private. To protect a LAN from sniffing, replace a hub with a switch, which is extremely effective in practice. Although sniffers can still access the LAN, it becomes more difficult for them to do so.

### **6.6.4.6 Physical Security**

To be physically secure against potential infections by malicious code, the system must be protected from physical attack. It is necessary to use a monitoring system to authenticate users to restrict physical access. Once access is granted, users’ actions must be monitored.

### **6.6.4.7 Detection Mechanism**

The detection mechanism enables users to detect the presence of malicious code, respond to its presence, and recover data or system files, if possible.

#### **Detect**

The objectives for detection are to discover attacks at or inside the protected boundary as well as to facilitate tracking and prosecuting of adversaries. Malicious code detection involves the continual probing of internal networks for the existence of services or applications infected by malicious code. This may be done routinely to assist in the selection of additional appropriate countermeasures, to determine the effectiveness of implemented countermeasures, or to detect all

types of malicious code. The following are typical security capability requirements associated with malicious code detection and system probing.

- Provide centralized operation.
- Provide automated reports.
- Recommend corrective action.
- Archive significant security events.
- Display and record status in real time.

## Respond

To respond to the presence of detected malicious code within a system or network, malicious code scanning must be performed. The following are typical security capability (counter-measure) requirements.

- Detect occurrence of infection and locate malicious software, e.g., a virus found in local memory.
- Perform scanning automatically, e.g., run continual malicious code scans throughout the day on systems.
- Implement scanning at the network gateway and at network components such as the desktop.
- Identify specific malicious code, e.g., macro virus.
- Remove malicious code from all infected systems so it cannot infect further, e.g., boot from uninfected write-protected boot diskette, then remove the malicious code from the system.
- Correct all effects of malicious code and restore system to original state, e.g., check all diskettes with files that may have been in disk drives during virus residency; reload files as appropriate.
- Reload program backups in cases where malicious code cannot be completely identified or where removal is not possible.
- Perform manually initiated scanning regularly, e.g., scan for malicious code after any Internet downloads.

## Recover

To recover data from the infection of malicious code, first concentrate on the specific area infected. The recovery process will take longer if malicious code has been in the system for a longer time. The number of computers that have been infected is also important as it affects time and resources for recovery. There are four stages in the infection process, and each stage requires a different amount of time and resources for recovery.



## UNCLASSIFIED

- 1) Local Memory Infection is the first stage of the infection process of a malicious code. If malicious code is caught in the first few hours before an appropriate host is found and replication begins, the following straightforward approach can be applied:
  - a) Power down,
  - b) Cold reboot with a clean, write-protected diskette,
  - c) Run a utility program to check hard disk and remove the few infected files, and
  - d) Locate and destroy the source containing the malicious code.
- 2) Local Disk Storage Infection is the second stage of the infection process. If an infection goes undetected, malicious code will infect an increasing number of programs and data files over time. In this case, the removal process becomes more complicated and several things could happen. If data and program files have been destroyed, it is possible that a complete reformat of the infected media will be required for recovery. File backups can also be dangerous due to the risk of reinfection during the restoration process. Total data loss may occur.
- 3) Shared File System Infection is the third stage of the infection process of malicious code. The risk of malicious code infecting the network attached to a computer is very high. If the infection is widespread, it is possible that a reformat of the entire medium will be required for recovery. Many things could happen during the recovery process. Again, file backups can be dangerous due to the risk of reinfection during the restoration process. One complication is numerous computers attached to the infected network will also be infected. The malicious code must be removed simultaneously from all workstations as well as the network. Another complication is that other users may have saved the malicious code unknowingly onto a floppy disk that may infect the entire network later.
- 4) System-wide Removable Media Infection is the final stage of the infection process. An infected computer will infect many of the physical disks it contacts. This is an extremely difficult situation to deal with for numerous reasons. Malicious code infects all types of removable media, such as floppy diskettes, removable hard disks, reel and cartridge tapes, etc. Once an infected disk has successfully infected a network computer, the number of infected disks drastically increases. A complication with all the infected disks is the possibility of reinfection after malicious code has been discovered and removed. Although scanning devices would have been updated since the original infection and would catch many possible reinfections, new malicious code, like the polymorphic virus that changes itself after each infection, could still compromise the network. Malicious code could also reach client sites and computers.

### 6.6.4.8 Administrative Countermeasures

Administrative concerns regarding infection by malicious code include training, policy, and coping with fears about malicious code and computers. “Viruses affect the emotional relationships that many people develop with their computer. Viruses could change the very nature of computing, from an essentially logical, predictable function to one fraught with

uncertainty and danger.” It is crucial for administrators to minimize stress due to computer viruses while not blaming employees.

Administrators can combat fears about malicious code and computers in many ways. The staff should be educated and motivated with regard to malicious code protection, detection, and recovery. A review of computer security with a risk analysis of exposure to infection and likely consequences should be conducted. A corporate policy with information about malicious code should be distributed to all staff. In addition, special briefing sessions should be held for all staff involved with computing functions. Administrators need to institute prevention programs that incorporate safe computing practices that should be posted at all terminals. Regular training sessions on safe computing should be scheduled. Administrators should also have a disaster recovery plan that is practiced on worst-case scenarios. Twenty-four-hour emergency phone numbers should be displayed. Most employees should also be cautioned to avoid overreaction and deploy backup facilities to minimize consequential damage.

## **6.6.5 Technology Assessment**

Before describing malicious code detection products, it is important to understand the different types of malicious code.

### **6.6.5.1 Types of Malicious Code**

#### **Viruses**

There are several classes of viruses, which range from innocuous to catastrophic. An understanding of each class is crucial to understanding the evolutionary process of an infiltrating virus. Innocuous viruses reside in unobtrusive areas of the system and cause no noticeable disruption. These viruses infect diskettes and other media that come into contact with the system but intend no damage. Humorous viruses cause aggravating events to occur, humorous messages to appear, or graphic images to be displayed. Although irritating, these viruses intend no damage and are commonly used for jokes. Potentially the most disruptive and difficult to detect are the data-altering viruses that alter system data. The viruses modify data file numeric information in spreadsheets, database systems, and other applications, such as changing all occurrences of the number three to the number eight. Catastrophic viruses erase critical system files and immediately cause widespread destruction. The viruses scramble key information tables and/or remove all information on all disks, including shared and network drives.

There are two main phases in the lifecycle of a virus.

- 1) The first phase, replication, could last a few weeks to several years. In this phase, viruses typically remain hidden and do not interfere with normal system functions. Viruses also actively seek out new hosts to infect such as attaching themselves to other software programs or infiltrating the OS. A virus that is attached to an executable program executes its instructions before passing control to the program (see Figure 6.6-3). These viruses are hard to detect because they only infect a small number of programs on a disk and the user does not suspect.

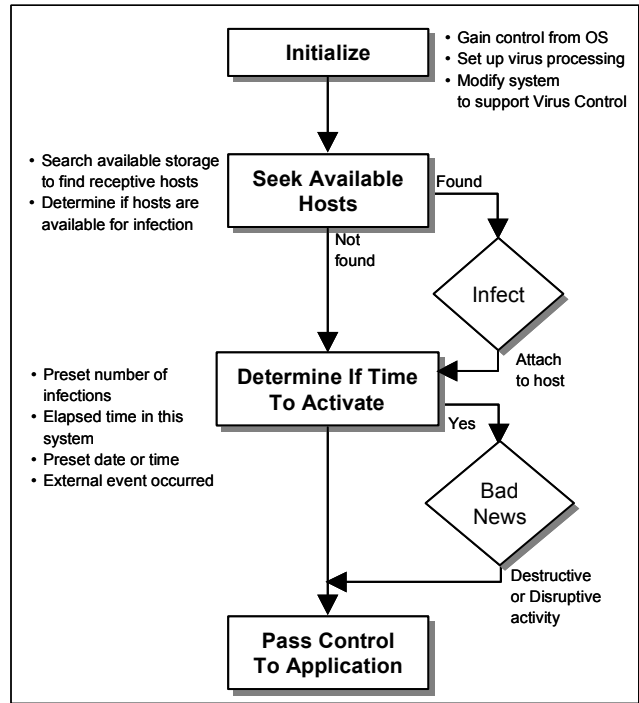

Figure 6.6-3. Virus Execution

- 2) During the second phase, activation, the beginning of gradual or sudden destruction of the system, occurs. Typically, the decision to activate is based on a mathematical formula with criteria such as date, time, number of infected files, and others. The possible damage at this stage could include destroyed data, software or hardware conflicts, space consumption, and abnormal behavior.

LAN users, administrators, and individual workstation/personal computer users should scan for viruses because of the unrealized potential for harm. Numerous viruses make major computing disasters inevitable. Extraordinary damage caused by these viruses can result in loss of man-hours, disruption of normal activities, and wasted monetary resources. Therefore, the unrealized potential for harm is the main reason why malicious code scanning and prevention are extremely important.

## Macro Viruses

The 1995 advent of macro programming for applications like MS Word and Excel automated repetitive keystroke functions, but also created an effective new way for viruses to spread. Word and Excel data files had previously been data-only files, like text-only e-mail messages—unable to harbor viruses because they did not include executable code.

Virus writers soon discovered these applications' macros could also be used to create viruses. At the same time, sharing of documents and spreadsheet files via e-mail became increasingly commonplace between users both within and between companies—creating the most effective virus carrier ever. Among the factors contributing to the dominance of macro viruses is the Visual BASIC for Applications (VBA) programming language, which makes it as easy for virus

writers to create time-robbing macro viruses as it does for users to create legitimate timesaving macro commands.

Once the macro-infected file is accessed, it replaces one of the Word or Excel standard macros with an infected version that can then infect all documents it comes into contact with. Macro viruses usually disable the macro menu selection, making users unable to see what macros are executing.

Today, macro viruses like ILOVEYOU are the most prevalent computer viruses in the wild—accounting for the vast majority of virus encounters in corporations. Today's widespread sharing of macro-enabled files, primarily through e-mail attachments, is rapidly increasing along with the associated macro virus threat.

Table 6.6-1, Comparison of Macro Viruses, describes the current impact of several macro viruses compared to an older virus, and the associated costs to corporations.

**Table 6.6-1. Comparison of Macro Viruses**

<b>Virus</b>	<b>Year</b>	<b>Type</b>	<b>Time to Become Prevalent</b>	<b>Estimated Damages</b>
Jerusalem, Cascade, Form	1990	Executable file, boot sector	3 Years	\$50 million for all viruses over 5 years
Concept	1995	Word macro	4 months	\$60 million
Melissa	1999	E-mail enabled Word macro	4 days	\$93 million to \$385 million
I Love You	2000	E-mail enabled Visual Basic script/word macro	5 hours	\$700 million

## Polymorphic Viruses

Polymorphic viruses alter their appearance after each infection. Such viruses are usually difficult to detect because they hide themselves from antivirus software. Polymorphic viruses alter their encryption algorithm with each new infection. Some polymorphic viruses can assume over two billion different guises. This means antivirus software products must perform heuristic analysis, as opposed to spectral analysis that can find simpler viruses.

There are three main components of a polymorphic virus: a scrambled virus body, a decryption routine, and a mutation engine. In a polymorphic virus, the mutation engine and virus body are both encrypted. When a user runs a program infected with a polymorphic virus, the decryption routine first gains control of the computer, then decrypts both the virus body and the mutation engine. Next, the decryption routine transfers control of the computer to the virus, which locates a new program to infect. At this point, the virus makes a copy of itself and the mutation engine in random access memory (RAM). The virus then invokes the mutation engine, which randomly generates a new decryption routine capable of decrypting the virus yet bearing little or no resemblance to any prior decryption routine. Next, the virus encrypts the new copy of the virus body and mutation engine. Finally, the virus appends the new decryption routine, along with the

## UNCLASSIFIED

Malicious Code Protection  
IATF Release 3.1—September 2002

newly encrypted virus and mutation engine, onto a new program. As a result, not only is the virus body encrypted, but also the virus decryption routine varies from infection to infection. This confuses a virus scanner searching for the telltale sequence of bytes that identifies a specific decryption routine. Therefore, with no fixed signature to scan for, and no fixed decryption routine, no two infections look alike.

A good way to contain a polymorphic virus is to set up false data directories or repositories to fool the attacker into thinking he or she has reached exploitable data. This can significantly reduce the risk of being attacked. The polymorphic virus executes in these false data directories, and is fooled into believing it has infected the entire system. In reality, the directories are either deleted or nonexistent, and the virus is thus unable to infect the system.

### **Stealth Viruses**

Stealth viruses attempt to hide their presence from both the OS and the antivirus software. Some simple techniques include hiding the change in date and time as well as hiding the increase in file size. Stealth viruses sometimes encrypt themselves to make detection even harder. Stealth viruses also enter systems through simple download procedures. Unsuspecting users can do little against this type of infection except download files only from trusted sources.

### **Worms**

Worms are constructed to infiltrate legitimate data processing programs and alter or destroy the data. Although worms do not replicate themselves as viruses do, the resulting damage caused by a worm attack can be just as serious as a virus, especially if not discovered in time. However, once the worm invasion is discovered, recovery is much easier because there is only a single copy of the worm program to destroy since the replicating ability of the virus is absent.

A prevalent worm, "Ska," is a Windows e-mail and newsgroup worm. An e-mail attachment disguised as "Happy99.exe" will display fireworks when executed the first time. After execution, every e-mail and newsgroup posting sent from the machine will cause a second message to be sent. Since people receive "Happy99.exe" from someone they know, people tend to trust this attachment, and run it. Then the worm causes damage by altering functionality of the WSOCK32 dynamic library link (DLL) file. Now the worm can actively attack other users on the network by placing itself on the same newsgroups or same e-mail addresses to which the user was posting or mailing.

### **Trojan Horses**

A Trojan horse is an apparently harmless program or executable file, often in the form of an e-mail message, that contains malicious code. Once a Trojan horse gets into a computer or network, it can unleash a virus or other malicious code, take control of the computer infrastructure, and compromise data or inflict other damage. The Melissa virus that struck in 1999 is a good example of a harmful Trojan horse. Attached to a harmless-looking e-mail message, the virus accessed Microsoft Outlook, replicated itself, and sent itself to many other

users listed in the recipient's e-mail address book. The resulting e-mail-sending flurry caused many Microsoft Exchange servers to shut down while users' mailboxes flooded with bogus messages.

Trojan horses can also be carried via Internet traffic such as FTP downloads or downloadable applets from Web sites. These can not only compromise enterprise computers and networks by rapidly infecting entire networks, but also can invite unauthorized access to applications that results in downtime and costs to business potentially reaching into the millions of dollars.

## Logic Bombs

Logic bombs are programs added to an already existing application. Most are added to the beginning of the application they are infecting so they are run every time that application is run. When the infected program is run, the logic bomb is run first and usually checks the condition to see if it is time to run the bomb. If not, control is passed back to the main application and the logic bomb silently waits (see Figure 6.6-4). When the right time does come, the rest of the logic bomb's code is executed. At that time, the hard disk may be formatted, a disk erased, memory corrupted, or anything else. There are numerous ways to trigger logic bombs:

counter triggers, time triggers, replication triggers (activate after a set number of virus reproductions), disk space triggers, and video mode triggers (activate when video is in a set mode or changes from set modes). There are also Basic Input Output System (BIOS) read only memory (ROM) triggers (activate when a set version of BIOS is active), keyboard triggers, antivirus triggers (activate when a virus detects variables declared by virus-protection software such as "SCAN\_STRING"), and processor triggers (activate if a program is run on a particular processor).

Logic bombs cannot replicate themselves and therefore cannot infect other programs. However, if the program that is infected is given to someone else and the right conditions are met on that computer it will go off.

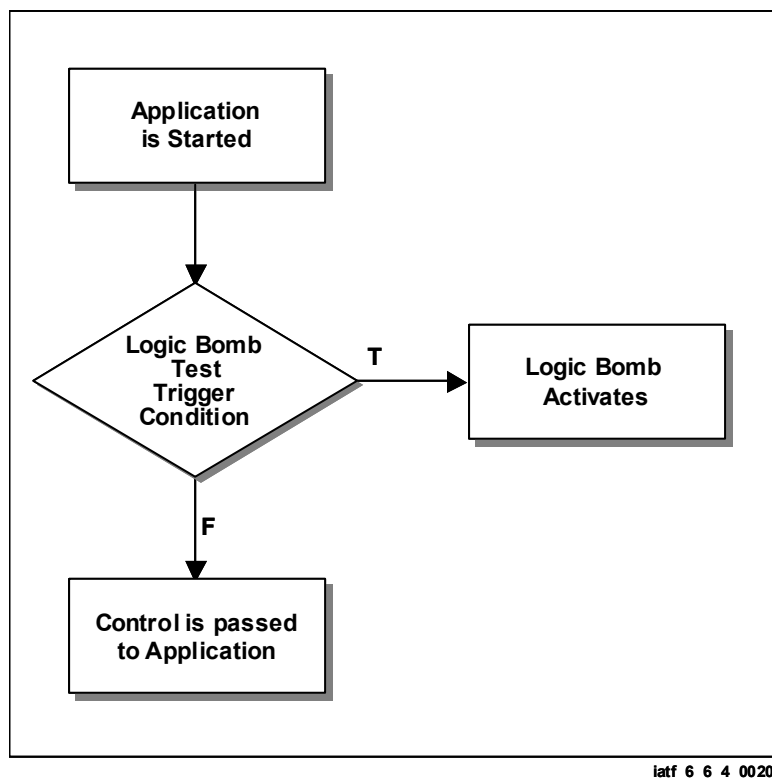

**Figure 6.6-4. Logic Bomb Execution**

## 6.6.5.2 Viruses and E-Mail

Today's office worker receives an average of more than 40 e-mail messages each day. Many of these messages have Microsoft Word or Excel data files attached, that may carry macro viruses. Since plain text data cannot carry the executable program code viruses need to copy and spread themselves, the text messages of electronic mail are, by themselves, unable to spread viruses. The virus danger from e-mail stems from attachments containing active executable program files with extensions such as: CLASS, OCX, EXE, COM, and DLL—and from macro-enabled data files. These attachments do not even need to be opened, as many mail clients automatically display all attachments. To prevent attachments from automatically being displayed, simply configure the mail client to prompt the user. Another safeguard is to identify file extensions prior to opening attachments so the infection of many computer systems may be prevented. These attachments could contain malicious code that could be masquerading as another file type.

## 6.6.5.3 Virus Creation

There are two types of viruses that can be created: simple viruses and complex viruses.

### Simple Viruses

Simple viruses do not attempt to hide themselves and are easy to write. Users with little computer knowledge can use Internet programs to create these viruses. Since thousands of sites contain virus source code, users can easily download and use existing viruses to infect systems. Users with slightly more computer knowledge may even alter existing virus source code or combine several viruses to create a new undetectable virus capable of compromising systems.

### Complex Viruses

Complex viruses require more source code than simple viruses, which is used to conceal them from systems. Knowledge of assembly language is required to manipulate interrupts so these viruses can remain hidden. While hiding, complex viruses replicate, and will destroy data later. A complex virus is divided into three parts: the replicator, the concealer, and the bomb. The replicator part controls spreading the virus to other files, the concealer keeps the virus from being detected, and the bomb executes when the activation conditions of the virus are satisfied. After these parts are created and put together, the virus creator can infect systems with a virus that current antivirus software cannot detect.

## 6.6.5.4 Virus Hoaxes

The Internet is constantly being flooded with information about malicious code. However, interspersed among real virus notices are computer virus hoaxes. Virus hoaxes are false reports about nonexistent viruses, often claiming to do impossible things. While these hoaxes do not infect systems, they are still time consuming and costly to handle. Corporations usually spend much more time handling virus hoaxes than handling real virus incidents. The most prevalent

virus hoax today is the “Good Times Hoax” that claims to put your computer’s central processing unit (CPU) in an “n<sup>th</sup>-complexity infinite binary loop that can severely damage the processor.” In this case, there is no such thing as an n<sup>th</sup>-complexity infinite binary loop. It is estimated virus hoaxes cost more than genuine virus incidents. No antivirus product will detect hoaxes because they are not viruses, and many panic when they receive a hoax virus warning and assume the worst—making the situation much worse.

## 6.6.5.5 System Backup

There are two main strategies to follow when performing a system backup.

### Workstation Strategy

The best backup strategy for workstations is to back up often. If the workstation is running the Windows OS, there are some simple backup tools already provided. There are also several utilities and programs available from other companies to assist users in performing backups. The following features can make backup chores more bearable: incremental backup, unattended scheduling, and easy, simple restoration. Incremental backup saves changes made since the most recent full or incremental backup. This is important because users who do not want to wait to back up a system can use incremental backup as a substitute for a lengthy full backup. Scheduling uses software automation to execute backup chores without the need for personal interaction. Although a backup medium must be selected and in place, the user does not need to be present for the actual backup. Zip drives and small tape drives are also cost-effective solutions used to back up workstation data.

### Network Strategy

The best backup strategy for networks is an approach that combines several features to save time and effort, and still assure complete backups. Execute full backups often. Since backups take up network, server, and/or workstation resources, it is best to run full backups when nobody is working. In addition, open files are skipped during backup and do not get backed up at all until some future time when the file is closed and not being used. Having few to no users holding files open will ensure the greatest backup saturation possible. Full backups are most efficiently executed in the evenings. Store the full backup tape off site. On each of the remaining workdays of the week, using a separate tape for each day, run an incremental backup and store it off site, too. The last full backup of the month should be permanently moved off site and held for archival purposes. Therefore, if a network is attacked by malicious code, these backup techniques will ensure data integrity and allow all systems to be recovered.

## 6.6.5.6 Types of Malicious Code Detection Products

Most computer malicious code scanners use pattern-matching algorithms that can scan for many different signatures at the same time. Malicious code detection technologies have to include scanning capabilities that detect known and unknown worms and Trojan horses. Most antivirus



products search hard disks for viruses, detect and remove any that are found, and include an auto-update feature that enables the program to download profiles of new viruses so that it will have the profiles necessary for scanning. The virus like signatures these programs recognize are quite short: typically 16 to 30 bytes out of the several thousand that make up a complete virus. It is more efficient to recognize a small fragment than to verify the presence of an entire virus, and a single signature may be common to many different viruses.

### 6.6.5.6.1 Pre-Infection Prevention Products

Pre-infection prevention products are used as the first level of defense against malicious code. Before the code actually attacks a system, prevention products should be applied. E-mail filtering products are available that do not allow executable programs or certain file types to be transferred. Also, options in browsers that limit the use of and/or disable Java and ActiveX plug-ins should be implemented. Simply changing browser options allows the user to see hidden files and file extension names. This could prevent opening an infected file masquerading as a normal text file. These essential pre-infection prevention products are the first level of defense against malicious code attacks.

### 6.6.5.6.2 Infection Prevention Products

Infection prevention products are used to stop the replication processes and prevent malicious code from initially infecting the system. These types of products, protecting against all types of malicious code, reside in memory all the time while monitoring system activity. When an illegal access of a program or the boot sector occurs, the system is halted and the user is prompted to remove the particular type of malicious code. These products act like filters that prevent malicious code from infecting file systems (see Figure 6.6-5).

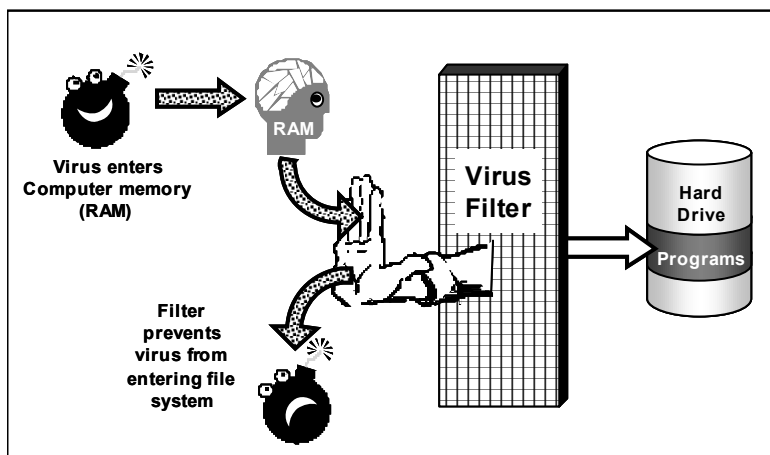

Figure 6.6-5. Virus Filter

### 6.6.5.6.3 Short-Term Infection Detection Products

Short-term infection detection products detect an infection very soon after the infection has occurred. Generally, the specific infected area of the system is small and immediately identified. These products also detect all types of malicious code and work on the principle that all types of malicious code leave traces. Short-term infection detection products can be implemented through vaccination programs and the snapshot technique.

## Vaccination Programs

Vaccination programs modify application programs to allow for a self-test mechanism within each program. If the sequence of that program is altered, a virus is assumed and a message is displayed. The drawbacks to this implementation include the fact that the boot segment is very hard to vaccinate, and the malicious code may gain control before the vaccination program can warn the user. The majority of short-term infection detection products use vaccination because it is easier to implement.

## Snapshot Technique

The snapshot technique has been shown to be the most effective. Upon installation, a log of all critical information is made. During routine system inspections (snapshots) the user is prompted for appropriate action if any traces of malicious code are found. Typically, these system inspections occur when the system changes: disk insertion, connection to different Web site, etc. This technique is difficult to implement in short-term infection detection products and is not widely used. However, when the snapshot technique is used with vaccination programs, an effective protection against malicious code is established.

### 6.6.5.6.4 Long-Term Infection Detection Products

Long-term infection detection products identify specific malicious code on a system that has already been infected for some time. They usually remove the malicious code and return the system to its prior functionality. These products seek a particular virus, and remove all instances of it. There are two different techniques used by long-term infection detection products: spectral analysis and heuristic analysis.

#### Spectral Analysis

Using spectral analysis, long-term infection detection products search for patterns from code trails that malicious code leaves. To discover this automatically generated code, all data is examined and recorded. When a pattern or subset of it appears, a counter is incremented. This counter is used to determine how often a pattern occurs. Using these patterns and the quantity of their occurrence, these products then judge the possible existence of malicious code and remove all instances of it. These products search for irregularities in code and recognize them as particular instances of malicious code.

#### Heuristic Analysis

Using heuristic analysis, long-term infection detection products analyze code to figure out the capability of malicious code. The underlying principle that governs heuristic analysis is that new malicious code must be identified before it can be detected and subsequently removed. This technique is much less scientific, as educated guesses are created. Because they are guesses, heuristic analysis does not guarantee optimal or even feasible results. However, it is impossible to scientifically analyze each part of all source code. Not only is this unproductive, it is terribly

inefficient. Typically, good educated guesses are all that is needed to correctly identify malicious code in source code.

These long-term infection detection products then remove all instances of the detected malicious code.

DOS file viruses typically append themselves on the end of DOS .EXE files. DOS file viruses can also append themselves to the beginning or end of DOS .COM files (see Figure 6.6-6). Other infection techniques are also possible but less common.

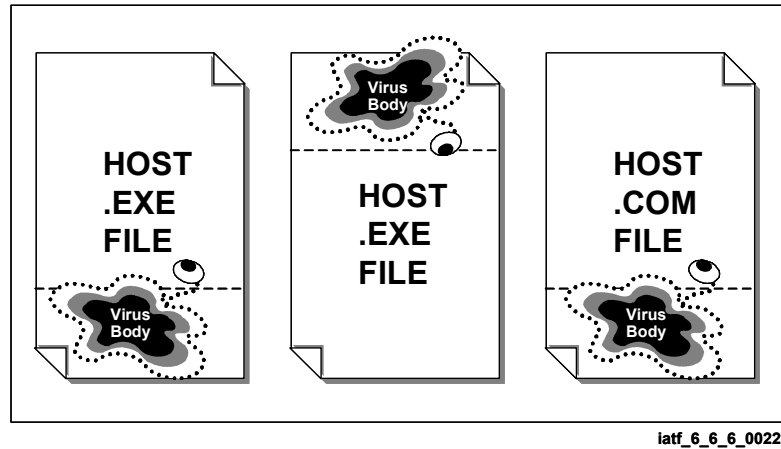

iatf\_6\_6\_0022

**Figure 6.6-6. DOS File Infection**

### 6.6.5.6.5 Interoperability

The different types of products mentioned above must be used together to create effective protection against all types of malicious code. Many layers of defense must be in place for a system to deal effectively with malicious code. If each type of product is implemented in a system, four different levels of defense are created. Before malicious code can attack a system, it must first get to the system through the pre-infection prevention products. If it gets that far, the second layer of defense, prevention products will attempt to stop the malicious code from replicating. If that is not successful, then the detection products will try to locate and remove the infection before it reaches the majority of the system. If the malicious code reaches the entire system, identification products can apply two different techniques to remove the infection. Each of these levels of defense is essential to the prevention of infection and the protection of a system.

Today, commercial software packages combine all the above levels of defense and provide malicious code protection services. With new computer systems connecting to the Internet daily, security problems will also grow at an exponential rate. Unless a well-defined security policy is in place, information technology managers will continue to lose the battle against computer viruses. Computer Emergency Response Team (CERT) statistics show the number of virus attacks rose from 3,734 in 1998 to 9,859 in 1999. In the first quarter of 2000, the CERT has reported 4,266 incidents. Despite the fact that antivirus applications are essential for the detection of known viruses, no mail filter or malicious code scanner can defend against a new mail worm attack. The recent “Love Bug” virus was caught quickly and still did a wealth of damage. It seems to only be a matter of time before crackers figure out how to send e-mail worms that infect systems without opening attachments. While not sophisticated enough to stop new viruses from entering systems, antivirus application makers are producing software that can prevent the damaging, data-altering effects of the malicious code.

## 6.6.5.7 Protection at the Workstation

There are numerous ways to protect a workstation from malicious code attacks. The implementation of pre-infection prevention, infection prevention, infection detection, and infection identification products provide four separate levels of defense and are essential in protecting a workstation. Although this is the best way to protect a workstation, other techniques can be applied. New malicious code protection products introduce a “sandbox” technology allowing users the option to run programs such as Java and ActiveX in quarantined sub-directories of systems. If malicious code is detected in a quarantined program, the system simply removes the associated files, protecting the rest of the system. Another protection mechanism is to allow continual virus definition updates that are transparent to the user. Implementing these updates at boot time, or periodically (1 hour, 2 hours, etc.) drastically reduces the chance a system will be infected with newly discovered malicious code. In the past 6 months alone, over 4,000 new viruses have been discovered. Without current virus definition updates, a system is left vulnerable to the devastating effects from malicious code.

## 6.6.5.8 Protection at the Network Gateway

When protecting a network, a number of issues must be considered. A common technique used in protecting networks is to use a firewall with Intelligent Scanning Architecture (ISA). (Figure 6.6-7) In this technique, if a user attempts to retrieve an infected program via FTP, HTTP, or SMTP, it is stopped at the quarantine server before it reaches the individual workstations. The firewall will only direct suspicious traffic to the antivirus scanner on the quarantine server. This technique scales well since LAN administrators can add multiple firewall or gateway scanners to manage network traffic for improved performance. In addition, users cannot bypass this architecture, and LAN administrators do not need to configure clients at their workstations.

Other useful scanning techniques for a network include continuous, automated malicious code scanning using numerous scripts. Simple commands can be executed and numerous computers in a network can be scanned for possible infections. Other scripts can be used to search for possible security holes through which future malicious code could attack the network. Only after fixing these security holes can a network withstand many attacks from malicious code.

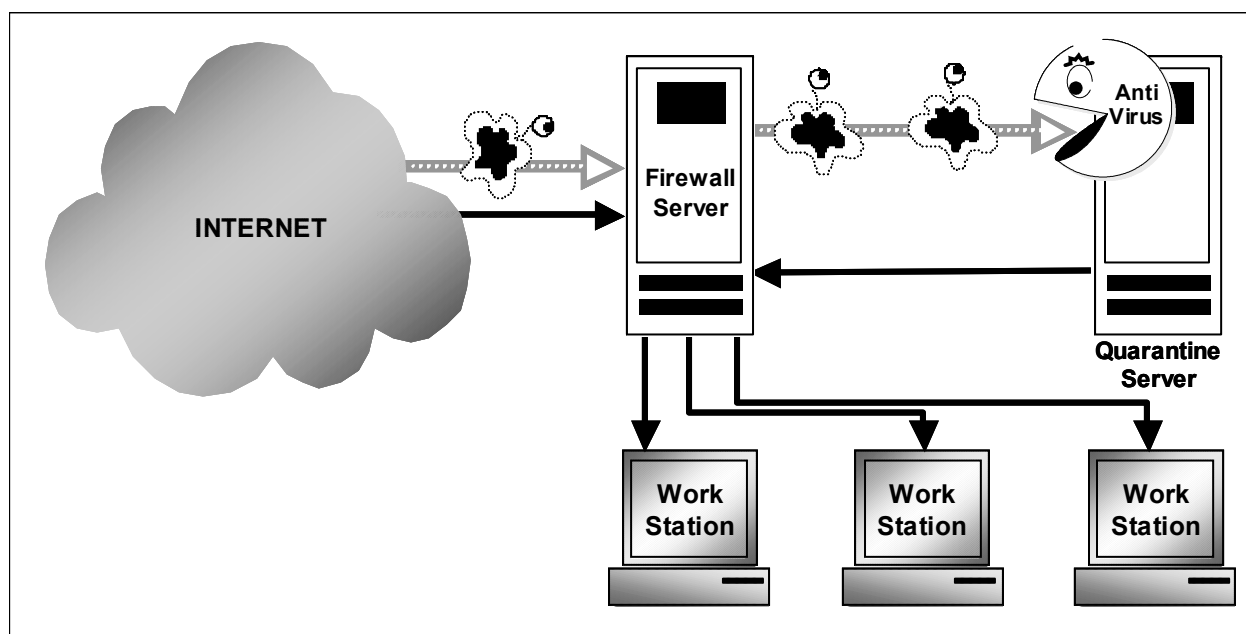

latf\_6\_6\_7\_0023

Figure 6.6-7. Intelligent Scanning Architecture (ISA)

## 6.6.6 Selection Criteria

When selecting antivirus products, two important guidelines must be followed. The “best” product may not be good enough by itself. In addition, since data security products operate in different ways, one product may be more useful than another in different situations. When selecting a particular malicious code protection product, its installation must be considered. Is the program shipped on compact disk (CD) or on 1.44MB disks? Does the installation itself operate smoothly? There should be no questions without answers when properly installing a product. This product should be easy to use, providing clear and uncluttered menu systems as well as meaningful screen messages.

Help systems are essential, as users need current information regarding all types of malicious code. The trend is to provide on-line help; however, manuals should also be provided with the product. The malicious code protection product should be compatible with all hardware and software and should not create conflicts. The company that produces the product should be stable and able to provide necessary local technical support for all questions and problems. The product should be fully documented, that is, all messages and error codes should be deciphered and full installation guides and how-to manuals should be provided. The computers to run this software must meet the hardware and software requirements specified by the manufacturer. The malicious code protection software should function properly and perform its duties without failing. Rating each of these categories will allow a company to choose the best malicious code protection product for its needs.

## 6.6.7 Cases

### 6.6.7.1 Case 1: Macro Virus Attack

Within a network environment, macro virus attacks are increasing exponentially. In Figure 6.6-8 below, a macro virus has infected an enclave via an e-mail attachment sent by an outsider. This e-mail attachment is a text document that enables macros. The e-mail recipient has e-mailed this document to his coworkers and saved it to diskette to view at home. A macro virus initiates when the document is opened and macros are enabled. As soon as the document is opened, the macro virus infects standard macros in the word processing program. After altering functionality of these standard macros, this virus replicates and infects many of the documents it comes into contact with.

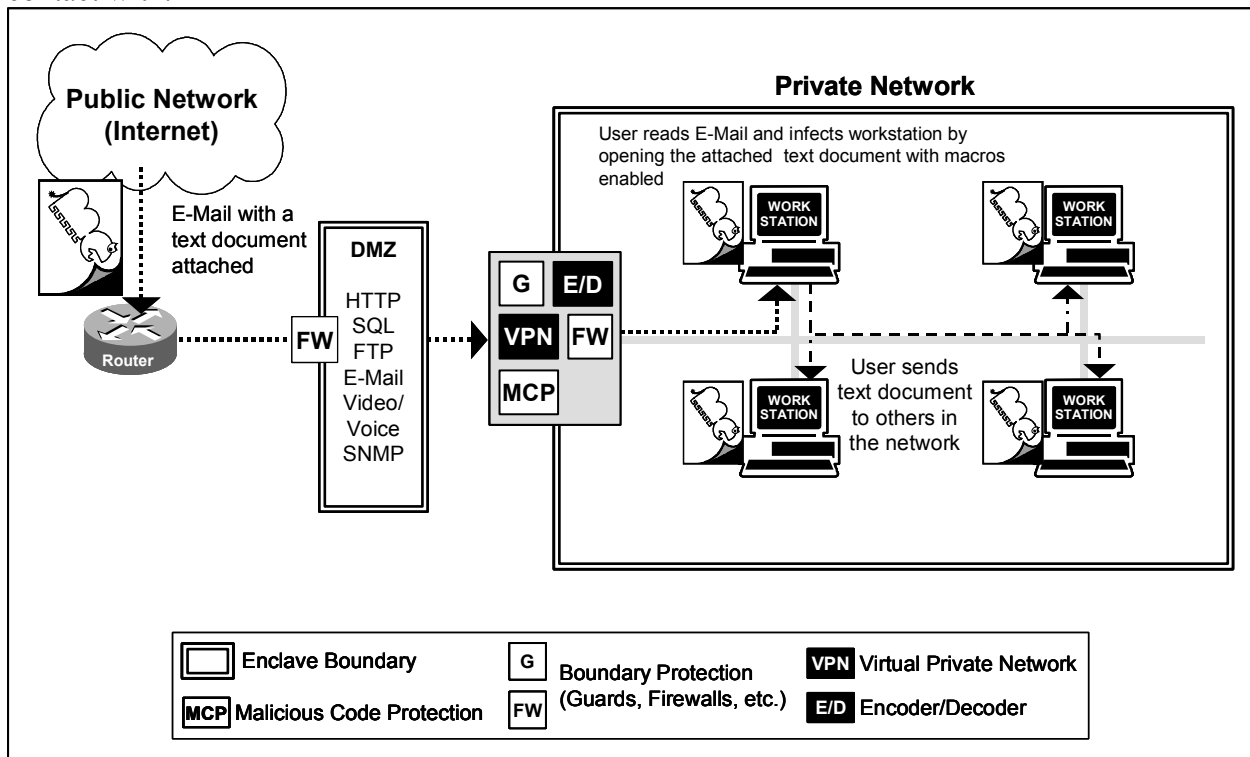

latf\_6\_6\_8\_0024

Figure 6.6-8. Macro Virus Infection

### 6.6.7.2 Case 2: Polymorphic Virus Attack

Polymorphic viruses represent the upper echelon of computer viruses. Today's polymorphic viruses are very difficult to detect using conventional antivirus search engines because they possess the ability to mutate themselves and conceal their digital identity as they spread. The unique ability of this form of virus to change its signature to avoid detection makes it virtually undetectable, and therefore potentially disastrous in nature.

Polymorphic viruses infect enclaves in much the same way as macro viruses. In Figure 6.6-9 below, a polymorphic virus enters a system through FTP, as an unsuspecting user retrieves a single file from a computer outside the network. The user then sends this file via an e-mail attachment to other coworkers throughout the network.

Once that file is accessed by any user, the polymorphic virus begins its programming and begins to replicate by e-mailing itself to the entire address book on its newfound host. It continuously changes its digital signature to escape the detection capabilities if any antivirus application is resident.

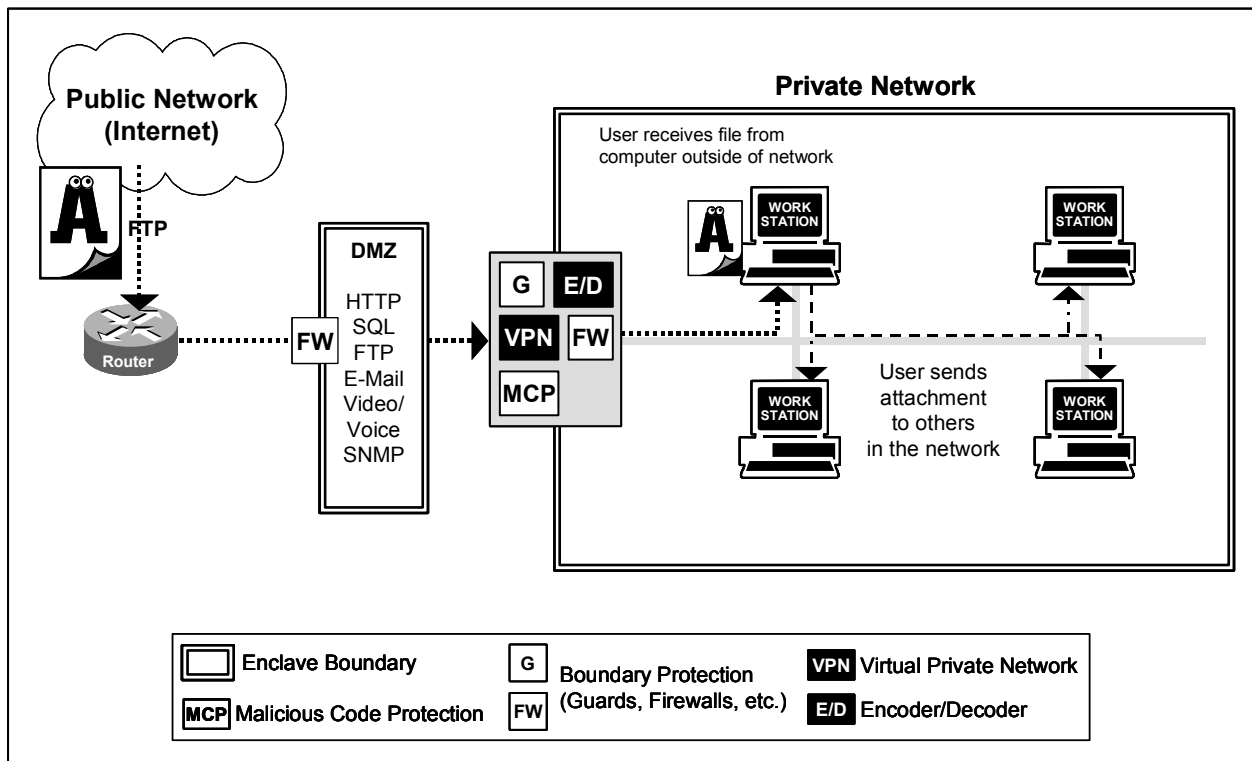
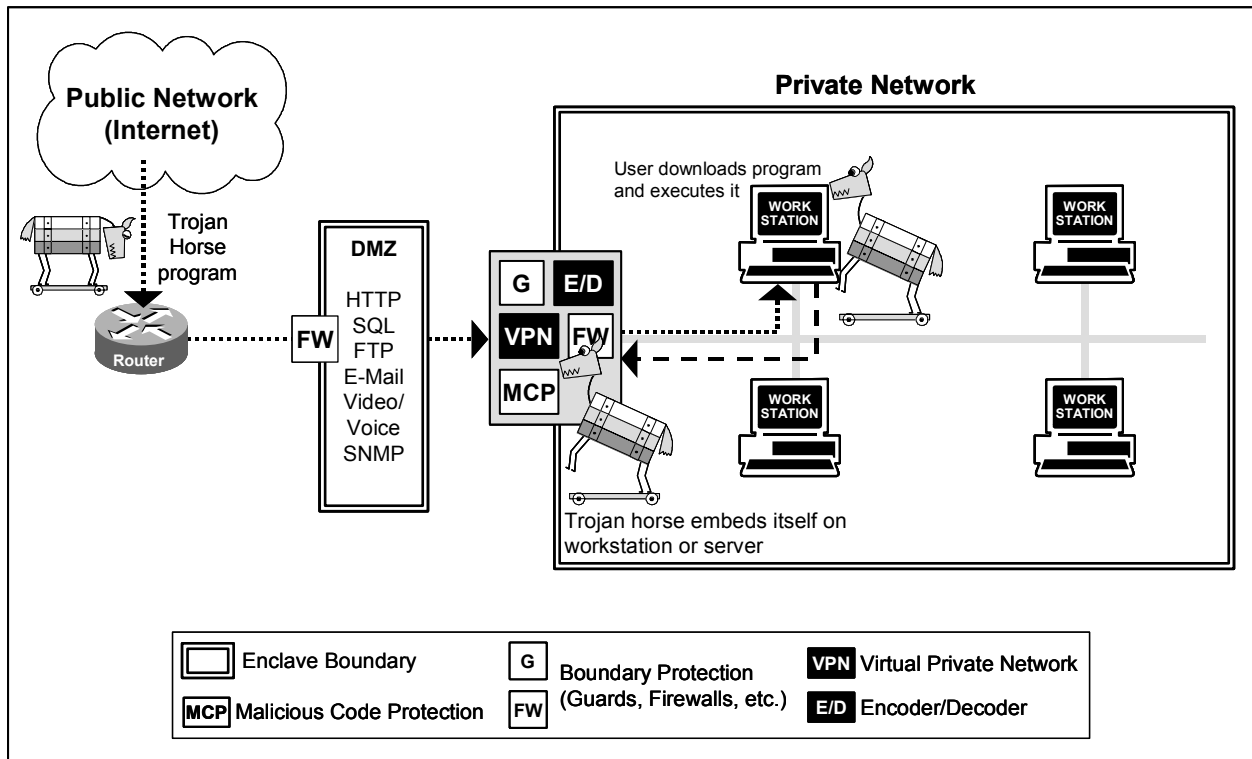

Figure 6.6-9. Polymorphic Virus Infection

### 6.6.7.3 Case 3: Trojan Horse Attack

There exists a growing threat from another type of malicious software, the Trojan horse. In Figure 6.6-10 below, a Trojan horse has been embedded into an existing network. A user downloaded a program that he thought was useful. However, after executing it, he realized it was not exactly what he needed. So, he deleted the file off of his computer. This unsuspecting user did not realize that the program downloaded was a Trojan horse that embedded itself into the network as a sniffer program after it was executed. Although this event occurred several weeks ago, there have been no problems in the network until now, when employees are noticing forged e-mails being sent to various clients.



iatf\_6\_6\_10\_0026

Figure 6.6-10. Trojan Horse Infection

## 6.6.8 Framework Guidance

In this section, guidance is provided on solutions that can be implemented so system infiltration by malicious code does not occur. Guidance will also be provided to detect and remove malicious code if it infects a system. Also, restoration guidance for the compromised system will be described.

### 6.6.8.1 Case 1: Macro Virus Attack

There are many ways to prevent, detect, respond to, and restore from macro virus attacks. The first level of defense is prevention so the macro virus does not reach the system. In a network environment, the first contact with the macro virus will be at the gateway. If the network is configured properly and using ISA (see Section 6.6.5.8, Protection at the Network Gateway), the macro virus should be stopped at the quarantine server. It is crucial to have current virus definition updates in the malicious code detection software on the quarantine server. These updates should occur continually, and should be transparent to the user. Implementing these updates at boot time, or periodically (hourly) drastically reduces the chance a system will be infected by a newly discovered macro virus. So, these updates prevent new macro viruses from infecting the entire network. If the macro virus is not stopped at the gateway, individual workstations should detect the presence of the macro virus and remove it. At the next layer of



defense, the individual user workstation will scan all incoming e-mail attachments for the presence of malicious code. If the malicious code detection software discovers the macro virus, the file is simply deleted and the system and network are preserved. If virus updates are automatic, virus definitions for the quarantine server and the individual workstation should be the same at the time of original system infiltration. In this case, the detection software at the workstation will probably detect the macro virus. If virus updates are not automatic, the individual user workstation will probably not detect the presence of the macro virus. This is because most users do not update their virus definitions as quickly as the system administrator of the quarantine server does. However, if this new macro virus has infected many workstations during a time frame of several days, the possibility of vendors discovering this macro virus and updating their virus definitions increases. Once this macro virus is detected by an individual workstation, the system administrator should automatically be notified.

If the macro virus does infect the network by infecting workstations, the virus must be detected and removed. Typically, new macro viruses are detected when a user notices abnormal computer behavior and that abnormality is investigated. Another way to detect viruses is through automatic virus scanning with virus software definition updates. Once the presence of the macro virus is detected, it is essential to update all virus definition updates in all copies of malicious code protection software throughout the network. Then, several methods can be applied to remove all instances of the macro virus. If the infection has occurred recently (within a few hours), short-term infection detection products should be used. Using the snapshot technique, or vaccination programs, all instances of the macro virus are detected and then removed. If the infection is not recent, long-term infection detection products should be used. Using spectral and/or heuristic analysis, all instances of the macro virus are detected and then removed.

However, if the macro virus has fully infected network workstations, the macro virus removal will then allow for the data recovery process to begin. By practicing simple system backup procedures (see Section 6.6.5.5, System Backup), applications and data can be restored from tape backups with minimal data loss. After updating malicious code definitions for all malicious code protection software, the reconstituted network is then ready to proceed with daily functions. Any damage caused by the macro virus is removed and the system is restored to its prior functionality.

If the unsuspecting user places the macro virus on his or her home computer via diskette, many problems can occur. Not only can the home computer become infected, but the network could also be reinfected. After modifying the infected file at home, the user can bring the file back to the office and infect his individual workstation. However, since the virus definitions should have been updated, the malicious code protection at the workstation should identify the virus and remove it. The user should then scan the home computer and remove all infections on that computer as well.

### **6.6.8.2 Case 2: Polymorphic Virus Attack**

Polymorphic viruses increasingly represent serious threats to computer networks. Prevention, detection, containment, and recovery from potentially lethal polymorphic computer viruses

should be an important task of every user, network administrator, and senior management officer. Establishment of an adhered to antivirus computer policy is a must for all those requiring any degree of protection for their systems against polymorphic virus attacks.

To successfully prevent polymorphic viruses from entering into a computer system, potential vulnerabilities must be identified and eliminated. Attackers often look to exploit the most obvious vulnerability of a computer network. Inadequate security mechanisms allow unauthorized users entry into computer systems, potentially allowing data to be compromised, replaced, or destroyed. Determent of attackers can be accomplished by having a predetermined computer protection plan in place. Also, contingency plans will enable the containment of and eventual recovery from a polymorphic virus attack. Another technique for preventing polymorphic virus attacks is to set up false data directories or repositories to fool the attacker. (See Section 6.6.5.1, Types of Malicious Code, Polymorphic Viruses.) Preparation for any incident of an attack and knowledge of how a given attack might occur is all part of the strategic virus protection plan that should be implemented prior to operation of a computer network.

Detection of polymorphic viruses becomes exponentially easier when the polymorphic virus signature is cataloged in an antivirus definition table and updated regularly to all systems gateways. This can happen in one of two ways. A user can notice altered functionality on a workstation, and after technicians investigate the problem, the polymorphic virus is finally discovered. Then, technicians inform vendors who update the virus definitions for others. A user can also remove the polymorphic virus after vendors have updated their virus definitions by downloading the newest virus definitions and scanning the entire system. Establishment of an updating policy not only for system gateways, but also for individual computer workstations, greatly increases the likelihood of preventing a polymorphic virus from entering and replicating itself on a given network.

Recovery methodologies are integral to the overall readiness of an antivirus prevention plan. Even the best prepared plans sometimes fail. Having written procedures in place to recover from a catastrophic event could mean the difference between a company surviving or going out of business. Recovery consists of virus-free tape backups of recent data, providing an environment free from all viruses, and restoring the network to pre-virus infection operation. There are inexpensive software applications that unobtrusively track disk activity in such a way that they can return a system to precisely the way it was prior to a computer virus incident. Backing up data or implementation of a mirroring solution is key to having a ready alternative source of providing information to users on a moment's notice. Unless uniformly adopted throughout the entire organization, a plan will have little chance of ever becoming successful. Dedicated personnel responsible for predetermined actions in anticipated situations are crucial for the protection of computer systems.

### **6.6.8.3 Case 3: Trojan Horse Attack**

Eradication of a Trojan horse encompasses many of the same procedures taken to eradicate macro and polymorphic viruses (see Sections 6.6.8.1, Case 1: Macro Virus Attack, and 6.6.8.2, Case 2: Polymorphic Virus Attack). This is because the Trojan horse can contain a virus inside

## UNCLASSIFIED

Malicious Code Protection  
IATF Release 3.1—September 2002

of the apparently harmless program. However, in this case, something else must be done to rid the network of the sniffer program hidden inside the Trojan horse. There is no one solution to prevent, detect, or remove sniffers. Since sniffer programs are extremely difficult to detect, the first level of defense against them is to make sniffing difficult. The network should use a switch instead of a hub to prevent sniffing of internal user passwords. By using an encryption mechanism for message transmissions and e-mail transactions, sniffing of important data such as passwords can be prevented. The use of “ssh” or other encrypted commands can help keep passwords private. Another precaution against password sniffing is the use of 1 time passwords. It does an attacker no good to sniff a password that is only valid during a very short time period.

In this case, the presence of sniffers is suspected since numerous forged e-mails have occurred. By applying the above measures of encryption and secure commands, sniffers can be rendered ineffective as passwords become much harder to decipher. It is also a good practice to change passwords often, or have the system administrator force users to change their passwords periodically to decrease the chance sniffer program users have time to decrypt encrypted passwords.

Also, it cannot be stressed enough how important it is to establish a complete and comprehensive malicious code protection backup system. If sniffer program users gain unauthorized access to the network, user applications and data files could be deleted. The only countermeasure in this case is to change all passwords and restore the system to prior functionality from full system backups. However, when systems are restored the sniffer must not be restored also.

## References

1. "A Clear and Present Danger," Information Week. May 22, 2000, p.166.
2. "AINT Misbehaving: a Taxonomy of Anti-Intrusion Techniques" SANS Institute Resources Intrusion Detection FAQ. Ver. 1.33.
3. Bassham, Lawrence E. and Polk W. Timothy, "Threat Assessment of Malicious Code and Human Computer Threats," NIST – Computer Security Division, October 1992.
4. "Batten Down The Digital Hatches!" Forbes. June 12, 2000 p.246.
5. CIAC, "H-05 Internet Hoaxes: PKZ300, Irina, goot Times, Deeyenda, Ghost," U.S. Department of Energy, Nov 20, 1996.
6. Chess, David., "The Future of Viruses on the Internet," Virus Bulletin International Conference In San Francisco, October 1997.
7. "DANGEROUS 'LOVE': Recent virus attacks prompt enhanced security measures," Computer Reseller News. May 29, 2000, p.45.
8. "Don't fall for a Virus Hoax," Sophos Virus Info, 23 Nov. 1999.
9. F-Secure, "Security Risks for the Road Warrior," Wed. July 12, 2000.
10. "Frost & Sullivan Awards Internet Security Systems the 2000 Market Engineering Marketing Strategy Award," Press Release. June 28, 2000.
11. Gabrielson, Bruce C., "Computer Viruses," INFOSEC Engineering, AFCEA Seminar, Burke, VA. Sept. 1994.
12. "An Introduction to Computer Viruses (and other Destructive Programs)," McAfee Network Security and Management.
13. Ludwig, Mark., The Giant Black Book of Computer Viruses, Show Low, AZ, 1995.
14. McAfee, John., Computer Viruses, Worms, Data Diddlers, Killer Programs, and Other Threats to Your System, Fifth Avenue, NY, 1989.
15. Micro, Trend., "Eliminating Viruses in the Lotus Notes Environment," 1999.
16. "Securing dot-com – New viruses, distributed security threats pose perpetual challenges to IT," eWeek, June 26, 2000 p.1.
17. Slade, Robert M., "Antiviral Protection Comparison Reviews," 1995.
18. Wack, John P. & Carnahan, Lisa J., "Computer Viruses and Related Threats: A Management Guide," NIST Special Publication.
19. "Understanding Symantec's Anti-virus Strategy for Internet Gateways," The Symantec Enterprise Papers, Volume XXX.

## UNCLASSIFIED

Malicious Code Protection  
IATF Release 3.1—September 2002

20. “Understanding and Managing Polymorphic Viruses,” The Symantic Enterprise Papers, Volume XXX.
21. “What Virus Is Lurking?—Better not touch that E-mail.” Computer Reseller News. June 5, 2000 p.1.

## 6.7 Multilevel Security

### 6.7.1 High-to-Low

The High-to-Low category is a subcategory of multilevel security (MLS). The goal of this category is to provide solutions giving installations the ability to connect networks of unlike classification (in generic terms, the classifications can be described as “High” and “Low”), as depicted in Figure 6.7-1. Given that the classifications of the data on the two networks are ordered, i.e., one is higher than the other is, users would have the ability to exchange Low data between the High and low networks. This ability is in spite of the fact that neither the High network nor the Low network has the ability to label the data. All data on the High side is considered to be High data. Users on the High network must explicitly designate data as Low and then request that it be transferred to the Low network.

This is a flow of Low data from High to Low. Likewise, Low data may flow from Low to High as a result of a user on the Low network sending data to the High network (e.g., in an e-mail message), or a user on the High network requesting data from the Low network (e.g., through a HyperText Transfer Protocol [HTTP] request to a Web server on the Low side.

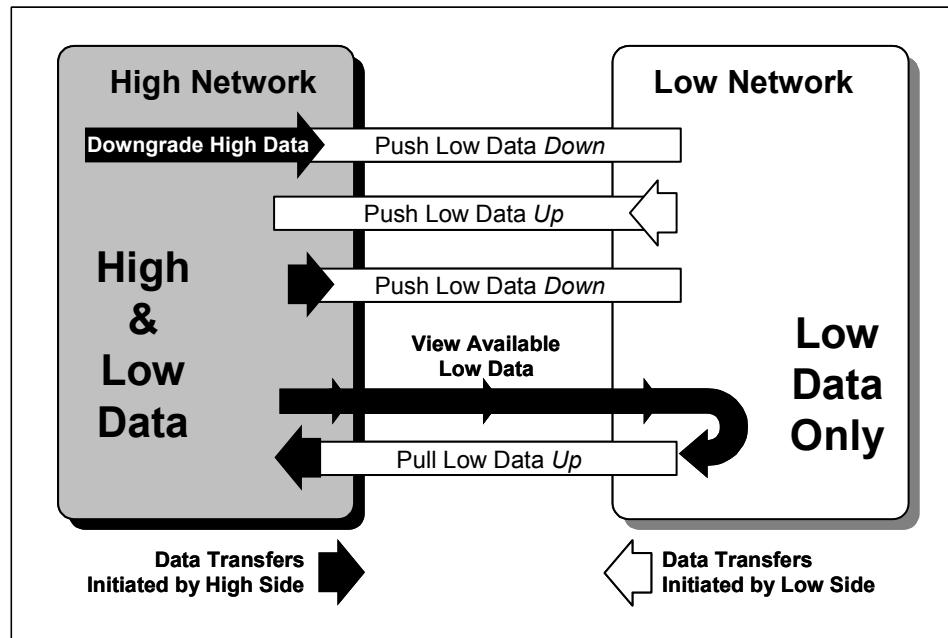

iattf\_6\_7\_1\_0003

Figure 6.7-1. High-to-Low Concepts

In no case is it desirable for High data to cross between the two networks in either direction. There are three primary statements within the policy for High-to-Low. First, the High data on the High network must never cross to the Low network. Second, the High network must be protected from attacks that could cause High data to be leaked to, modified by, or destroyed by users on the Low network. Third, High network resources may not be utilized, modified, destroyed, or made unavailable by unauthorized Low network users.

These requirements apply to all High-to-Low connections, regardless of the actual classifications. Possible scenarios include Secret-to-Unclassified, Secret U.S.-to-Secret

Releasable, Top Secret-to-Secret, and High-to-Low connections that are not formally classified such as (Unclassified but Controlled)-to-Unclassified Internet. It is the intention of this framework to specify requirements in a form that is generic enough to address all popular network services, e.g., e-mail, HTTP, File Transfer Protocol (FTP), database. The requirements will be phrased in terms of “pushing” and “pulling” data between the two networks.

## 6.7.1.1 Target Environment

There are three target environments that this framework will address:

- 1) Allow users on the High network to push Low data to users on the Low network, and allow users on the Low network to push Low data to users on the High network.
- 2) Allow users on the High network to downgrade data to Low, and push that data to a server on the Low network for subsequent pull by users on the Low network.
- 3) Allow users on the High network to view and import (pull) data that exists on the Low network.

In the remainder of this framework, the above three capabilities will be referred to, respectively, as—

- Communication.
- Releasability.
- Network access.

## 6.7.1.2 Consolidated Functional Requirements

### 6.7.1.2.1 Requirements for Communication

Current requirements are—

- Send and receive electronic mail between the High network and the Low network.
- E-mail must conform to standards used in the wider community.
- E-mail must allow users to send and receive attachments in both directions.

Anticipated requirements are—

- Enable users to use Chat as a means of communication between High and Low network users.
- Enable Internet telephony between High network users and Low network users as the technology becomes available.
- Enable video teleconferencing between High network users and Low network users.

### 6.7.1.2.2 Requirements for Releasability

Current requirements are—

- Enable authorized users on the High network to designate and push—e.g. FTP, e-mail, HTTP Post, etc.—data to the Low network that is releasable to users on the Low network.
- Enable authorized users on the Low network to access the released data using Web technology, FTP, database access techniques.
- Released data may be restricted to certain users, or it may be made publicly available.
- Released data may be text, video, images, audio, or executable software.

### 6.7.1.2.3 Requirements for Access

Current requirements are—

- Users on the High network must be able to access the vast information resources on the Low network.
- Access methods may be HTTP, FTP, Gopher, Wide Area Information Service (WAIS), SQL, or Web Push. With Web Push, as a result of a previous High-to Low-access request, information is pushed onto the High network from the Low network.

## 6.7.1.3 Attacks and Potential Countermeasures

The following section itemizes previously identified attacks that were explained in Chapter 3, System Security Methodology, of this document, and matches these attacks with potential countermeasures that may be included in solutions addressing the High-to-Low requirement category.

### 6.7.1.3.1 Passive Attacks

- **Traffic Analysis.** As of now, no technical countermeasure has been identified that is appropriate for inclusion in High-to-Low requirement category solutions.
- **Monitoring Plaintext.** The appropriate countermeasure to this attack is to deny access to the data by unauthorized users by encrypting the data or by using other data separation techniques that will restrict unauthorized release of data. (Note that utilizing encryption is possible only when both parties have access to the same algorithms and keys and the same capability to encrypt and decrypt the data properly.)
- **Decrypting Weakly Encrypted Traffic.** Countermeasures are to use adequate encryption algorithms and maintain sound key management.



### 6.7.1.3.2 Network-Based Attacks

- **Modification of Data in Transit.** The countermeasure to this attack is to use digital signatures or keyed hash integrity checks to detect unauthorized modification to the data in transit.
- **Insertion of Data.** There are many countermeasures to the malicious insertion of data. They include the use of timestamps and sequence numbers, along with cryptographic binding of data to a user identity, to prevent replay of previously transmitted legitimate data. Data separation or partitioning techniques, such as those used by firewalls and guards deny or restrict direct access and the ability to insert data by Low-side agents into the High-side network.
- **Insertion of Code.** Virus scanning by High-side users and enclave protection devices attempts to detect incoming viruses. Cryptographically authenticated access controls may be utilized to allow data only from authorized sources to enter the High network. Audit and intrusion detection techniques may detect breaches in established security policy and anomalies.
- **Defeating Login Mechanisms.** The most appropriate countermeasure for this is cryptographic authentication of session establishment requests.
- **Session Hijacking.** The countermeasure for this is continuous authentication through digital signatures affixed to packets, or at the application layer, or both.
- **Establishment of Unauthorized Network Connections.** There is no technical countermeasure for this. It is incumbent on the management and administration of the local network to prohibit unauthorized connections between High and Low networks, and to enforce that policy through nontechnical means. Various commercial tools may be utilized by system administrator personnel to detect such connections.
- **Masquerading as an Authorized User.** The appropriate countermeasure is to use cryptographic authentication in conjunction with timestamps or sequence numbers to prevent replay of authentication data. Another countermeasure to prevent stealing an authentic session is to cryptographically bind authentication data to the entire session/transaction.
- **Manipulation of Data on the High Side.** The appropriate countermeasure is to permit only authorized users to access the data on the High side using cryptographic authentication and data separation techniques.

### 6.7.1.3.3 Insider Attacks

- **Modification of Data or Modification of Security Mechanisms by Insiders.** The primary technical countermeasure is to implement auditing of all security relevant actions taken by users. Auditing must be supported by timely, diligent review and analysis of the audit logs generated. Other countermeasures to these attacks are nontechnical and

therefore not addressed by the High-to-Low requirement category solutions. Nontechnical countermeasures include personnel security and physical procedures.

- **Physical Theft of Data.** Again, the countermeasures to these attacks are nontechnical and therefore not addressed by the High-to-Low requirement category solutions. Appropriate nontechnical countermeasures include personnel security and physical security procedures, which inhibit actual removal of data, either in printed form or on storage media.
- **Covert Channels.** The countermeasure against a covert channel between the High and Low networks is a trusted guard function that examines network header fields and network messages for possible unauthorized information.

#### 6.7.1.3.4 Development and Production/Distribution Attacks

- **Modification of Software During Development, Prior to Production.** The countermeasures for threats during this phase include use of strong development processes/criteria such as Trusted Software Development Methodology and subsequent evaluation of software by third-party testing using high assurance methods and criteria such as the Trusted Product Evaluation Program (TPEP) and Common Criteria testing.
- **Malicious Software Modification During Production and/or Distribution.** The countermeasures for threats during this phase include high assurance configuration control, cryptographic signatures over tested software products, use of tamper detection technologies during packaging, use of authorized couriers and approved carriers, and use of blind-buy techniques.

#### 6.7.1.4 Technology Assessment

This section discusses general technology areas that can be used in system solutions to address the functional and related security requirements associated with the High-to-Low requirement category. Section 6.3.1.5, Requirement Cases, proposes various system-level solutions that build upon these general technology areas. The proposed security countermeasures included in each system solution result from our analysis of user target environments; functional requirements applicable to the *communications*, *releasability*, and *network access* requirements, and attacks and potential countermeasures as discussed in previous sections.

The framework divides the technology of protection between High and Low networks into three categories:

- 1) Data Separation Technologies
- 2) Authenticated Parties Technologies
- 3) Data Processing, Filtering, and Blocking Technologies.

This categorization allows us to make some high-level assessment of system assurance provided for groups of similar solutions, thereby ordering solutions in terms of security robustness. These three generic categories of potential solutions are explained in more detail in subsequent paragraphs of this section.

#### 6.7.1.4.1 Data Separation Technologies

System solutions that would logically fit into this technology category would allow users who are located in High-side protected enclave environments to have access to both High network and Low network data, but prohibit pushing and pulling of data between these two networks. Typically, solutions in this category rely upon physical separation of data (from user interface to redundant distribution networks) in order to provide data segregation between High and Low applications.

In most cases High-side users are restricted from using sophisticated automated means that allow for the storage or manipulation of Low-side generated data on the High network. In addition, High-side users are also restricted from directly extracting Low data from the High network applications, or using a broad range of applications to move the extracted data to the Low network.

All of the proposed solutions that are included in this category do provide for the data transfer techniques previously described as *communications*, *releasability*, and *network access*, but do so only within networks of the same level.

For *communications* exchanges, typical solutions in this category allow access for High-side users to redundant network access points, which are individually connected to both networks, i.e., High network users have access to two network access points, one for the High network and one for the Low network. Users may have two processors with shared monitors and keyboards, or several users may be provided access to a shared Low network interface located in a centralized location. Likewise, for both *releasability* and *network access* exchanges, users on the High network side will interface to logically separated network interfaces.

The economics of solutions that fit into this category must be examined and a tradeoff analysis completed that compares the savings resulting from greatly simplified security mechanisms and reduced complexity of security management infrastructure and personnel support with the cost of redundant local networks and network management. The primary advantage of data separation solutions is that all of the solutions in this category provide the highest degree of system-level security, and may in fact be the only solutions that are acceptable for very high assurance networking requirements. These are very secure system topologies, providing the best protection from both passive and network attacks.

These solutions do not allow data to flow between the High network and the Low network. Hence, they are robust in preventing attack of the High network and leakage of High data to the Low network. The only true data separation technology is physical isolation of the network. Any connection between the two networks will create the potential for at least minimal leakage

via covert channels, as well as the operational risk of attacks from Low to High. Solutions here include—

- Isolated Networks.
- Secure Network Computers.
- Starlight Interactive Link.
- Compartmented Mode Workstations (CMW).

Each of these is discussed below.

## Isolated Networks

This solution is simply to maintain two networks, one for High data and one for Low data. The two networks are never to be connected together. This would require redundant infrastructures, at additional cost. However, the cost can be justified in environments where users cannot tolerate the risk that the High data might be compromised or the High network attacked.

The number of workstations on each network is a function of the need within the organization to have individuals with access to both networks. Perhaps the Low network can be accessed via shared workstations if it is not necessary for all users to have access from their desktops.

The specific capabilities addressed by this solution are communication and network access. Automated releasability to the Low network of data created on the High network is not addressed by this technique. Regrading, and subsequent release to a co-located Low network computer, of information contained on the High network computer may be performed by overt human intervention, e.g., human review and retyping of data on the Low network computer or optical scanning. Communication and network access are addressed by allowing the user who has access to a terminal for each network to exchange electronic mail, participate in Chat sessions, and perform World Wide Web (WWW) browsing with other parties on either network by using the appropriate terminal.

While many customers wish to avoid using separate networks, this option bears consideration with the increased availability of low-cost personal computers (PC) and network computers. The cost of implementing and operating two separate networks might actually be less than implementing and managing sophisticated network security systems. Furthermore, the richness of the network access will be unimpaired by the security at the boundary of the High network.

## Secure Network Computers

Research is being done on a secure network computer that will employ a cryptographic token to separate data on the network. The concept is that the network will be classified for Low data, while having servers connected that process High data. All High data on the network is encrypted to provide separation. The workstations on the network are all *single level at a time* with only volatile memory. They are network computers that accept a cryptographic token to encrypt and decrypt all communications over the network. Depending on the token placed in the network computer at any one time, it will be able to access either High servers or Low servers,

## UNCLASSIFIED

Multi-Level Security  
IATF Release 3.1—September 2002

but not both. When the token is changed, the volatile memory of the network computer is cleared. Since this is a research project, no commercial products are yet available. Hence, this is identified as a technology gap that is being addressed.

When secure network computers become available, they will allow communication and network access on High networks and Low networks using the same device. They will not allow automated regrading of data, so it would not be possible to forward an e-mail message from the Low network to recipients on the High network. Likewise, the secure network computer does not support automated releasing of Low data from the High network. To release Low data residing on the High network, users would be required to perform a human regrade procedure, using nonautomated methods such as retyping of the data or optical scanning.

### **Starlight Interactive Link**

This is a technology that is being developed in Australia that allows a single monitor, mouse, and keyboard to have access to two different computers. One computer is connected to the High network, and one is connected to the Low network. The technology allows *single level at a time* access to the two networks from a single location. Data does not transfer between the two without human review. It is possible to cut-and-paste data from Low to High only (never High to Low) using the standard X Windows cut and paste capability. This can be done only with human intervention. There is no way to automate the regrading of data. It should be noted that the cut-and-paste Low-to-High capability introduces risk that the data pasted to the High network could contain malicious code.

The implementation employs a one-way fiber optic link with the Low computer. This prohibits data leakage from High to Low. Because of the fiber optic link, data can only flow away from the Low computer to the display; it can never flow from the display to the Low computer.

The Starlight Interactive Link supports communication and network access from a single location. It does not support automated releasability from the High network to the Low network.

Since the Starlight Interactive Link is not yet a commercial product, it is identified as a technology gap.

### **Compartmented Mode Workstations**

Another solution in the data separation class is to use CMWs or higher assurance workstations, if available. These could be judiciously allocated to the users who need to access both the High network and the Low network. With this approach, each user is then able to access both the High network and the Low network.

The specific capabilities addressed by this solution are communication, network access, and releasability. Communication and network access are addressed by allowing the user who has access to a CMW, which is connected to each network, to exchange electronic mail, participate in Chat sessions, and perform WWW browsing with other parties on either network by using a window dedicated to the proper network. Releasability and communication between the High

network and the Low network are addressed by the CMW *cut-and-paste* and *downgrade capability*. This operation allows users to highlight information in a High window and use the cut or copy command to place it in a buffer for review. The resulting information is then downgraded, appropriately classification marked, and displayed to the user in a Low window for visual review and release.

Cut and paste between sensitivity levels is an action that requires the CMW to be configured with this privilege; it is not allowed by default. If the CMW is not configured with this privilege, complete logical data separation is achieved.

### 6.7.1.4.2 Authenticated Parties Technologies

System solutions that would logically fit within this category are solutions that mandate the use of cryptographic authentication mechanisms prior to allowing access. Examples of actions that could be governed by this technology are—

- Allowing High users to access servers on the Low network when the servers can be authenticated.
- Allowing High users to release data from the High network based on their authenticated identity.
- Allowing Low data to enter the High network when the Low data is cryptographically bound to an authorized individual through a digital signature.

Authenticated access is widely available and is supported by a large number of standards and protocols. It allows two parties that intend to exchange data to identify themselves to one another and positively authenticate their identities. Hence, they become mutual trusting parties. The data that flows between these trusting parties is at the level of the lower party. This paradigm is applicable to the previously discussed modes of data exchange: *communication*, *releasability*, and *network access*.

Authenticated access solutions typically address *communication* data exchanges by use of digital signatures for electronic mail messaging applications, e.g., Message Security Protocol (MSP) or Secure/Multipurpose Internet Mail Extension (S/MIME). Such solutions typically involve the concept of protected enclaves for the system-high users that are separated from the system-low network users by some sort of enclave boundary protection device such as a guard or firewall. In such a topology, Low network users might utilize digital signature technology to authenticate themselves to High network users. Also, the guard might incorporate access control list (ACL) mechanisms to make access decisions governing the set of users that are authorized to release information from the High network. Access control lists can also be used to restrict the set of Low network users that are authorized to push data up to the High network.

Likewise, authentication solutions are applicable to *releasability* data exchanges in that the releaser can digitally sign data to be released. Again, enclave boundary protection systems such as guards might utilize ACLs that would regulate who in the system-high network is authorized

## UNCLASSIFIED

Multi-Level Security  
IATF Release 3.1—September 2002

to release data from the High-side network. The enclave boundary protection system might also perform content review of the data submitted for release.

Lastly, authentication solutions are applicable to *network access* data exchanges typically through the use of commercial off-the-shelf (COTS) protocols such as Secure Sockets Layer (SSL), Secure HyperText Transfer Protocol (S-HTTP), SOCKS, Secure Electronic Transaction (SET), and Internet Protocol Security (IPSec) for Web access, database access, FTP access, etc.

It is logical to conclude that security is enhanced if parties that are mutually trusting create a closed virtual community. The downside of these types of solutions is that, in general, they mandate that both parties have compatible security mechanisms to strongly authenticate themselves to one another. Therefore, the implication is that the number of Low network resources that are accessible is greatly reduced to include only those that are “security enabled.” In the case of *network access* requirements, the requirement to be security enabled may greatly reduce the availability of access to public information resources.

It must also be noted that authentication solution topologies normally necessitate a very restrictive policy whereby activity is allowed only with other parties that are authenticated as part of the closed, and therefore trusted, community. Conversely, if the community is opened by a single party who interacts with another party outside of that community, then the entire community is potentially vulnerable to attack.

While authentication technologies are widely available, they have yet to become fully mature. For a discussion of hurdles that must be overcome, see Section 6.3.1.4, Technology Gaps.

Solutions using Authenticated Parties include the following:

- Authentication between clients and servers using SSL.
- Host-to-host authentication using IPSec with the Authentication header.
- Authentication at the application layer via digital signatures.

These are discussed below.

### **Authentication between Clients and Servers Using SSL**

SSL[1] is becoming a popular security protocol for implementing privacy and authentication between communicating applications. It is a transport layer security protocol, enabling the encryption and authentication of arbitrary applications. The protocol prevents eavesdropping, tampering with information, and forging of information sent over the Internet.

The SSL protocol includes a lower level protocol (called the SSL Record Protocol) that encapsulates higher level security protocols. The SSL Handshake Protocol is one such encapsulated protocol. It allows communicating parties to authenticate one another and to establish cryptographic algorithms and keys at the start of a communication session.

Connections using SSL have three properties:

- The communication is private. The initial handshake uses public key cryptography to define a secret key. The secret key is then used with symmetric cryptography to encrypt all communications.
- Clients and servers can authenticate one another during the handshake using public key cryptography.
- The entire communication is protected against tampering or insertion of data. Each datagram has a Message Authentication Code that is a keyed hash value.

The SSL protocol can be used for network access between clients on the High side and servers on the Low side. This can give confidence that the server is trusted to some degree. A policy requiring that SSL be used for all network access between High and Low would effectively permit access only to servers on the Low side that have the ability to authenticate using SSL. However, such a policy might not be useful if there are some Low servers that have the ability to authenticate, but should not be included within the set of servers to which access is allowed. The goal should be, not just authentication. Rather, the goal should be but access control, with authentication used as a means to implement access control. This is accomplished by maintaining a list of Low servers that, once authenticated, can be accessed by High clients. That list is best maintained by an enclave boundary protection system, e.g., guards.

If an enclave boundary protection system is in use, SSL can be used between the enclave boundary and the Low server. If the SSL is between an enclave boundary protection system and the Low server, then guarding, filtering, and blocking technologies can also be applied to allow access to only those Low servers that are on an access control list. The enclave boundary protection system would keep a list of servers to which network access is allowed, and would enforce the policy that no network access is allowed to any other servers. SSL could also be used as a basis for communication via e-mail, Chat, Whiteboarding, or other protocols, since it is a transport layer protocol and is independent of the application. Since SSL also gives the capability to encrypt all application layer data, the communication between the enclave boundary and the Low server is private.

SSL can also be used between the client on the High network and the enclave boundary. This allows the enclave boundary protection system to maintain a list of High clients that are authorized to communicate with users on the Low network, to access information on the Low network, and to release information to the Low network.

Using SSL for end-to-end encryption and authentication from High clients to Low servers limits the effectiveness of an enclave boundary protection system. In this case, the enclave boundary protection system cannot see the application layer information being communicated between the client and the server. Therefore it can make access control decisions only on information in the transport layer and layers lower than the transport layer. Thus, a tradeoff must be made between end-to-end security and the access control capabilities of an enclave boundary protection system. However, the benefits of using an enclave boundary system to enforce access control can be argued to outweigh the loss of uninterrupted end-to-end encryption and authentication.



For High-to-Low, the optimal use of SSL is to have two SSL connections meeting at the enclave boundary protection system. One connection is between the High host and the enclave boundary; another is between the enclave boundary and the Low host. This allows the enclave boundary protection system to perform filtering, authentication, access control, and auditing of all traffic passing from High to Low. To perform this function, the enclave boundary system would use a proxy that effectively glues two separate SSL sessions together.

## **Host-to-Host Authentication Using IPSec With the Authentication Header**

Like SSL, the IPSec security protocols allow encryption and authentication of all information above the network layer in the Transmission Control Protocol (TCP)/IP stack. Unlike SSL, IPSec resides at a lower layer in the communication stack, and has the capability to completely encapsulate IP packets, including the source and destination addresses. Where SSL can be described as a process-to-process security protocol, IPSec is sometimes referred to as a host-to-host security protocol.

In connections between High networks and Low networks, IPSec can be useful in authenticating the hosts at the communication endpoint, and in providing privacy of the data being transmitted. Since IPSec is at a lower layer in the communication stack than SSL, IPSec can help in prevention of spoofed IP addresses.

IPSec is of little use in High-to-Low connections without an enclave boundary protection system at the point where the High network is connected to the Low network. The enclave boundary protection system is needed to perform access control between High and Low. At the same time, the enclave boundary protection system is rendered useless if IPSec with encryption is used between the High host and the Low host, since the communications would be encrypted with a key private to those two endpoints. For High-to-Low, the best use of IPSec is between the Low host and the enclave boundary protection system, and also between the High host and the enclave boundary protection system. This allows the enclave boundary protection system to authenticate both endpoints of the communication, although it creates a complexity in key management for the enclave boundary protection system. Since most enclave boundary protection systems that are suitable for High-to-Low do not perform IPSec, this is considered a technology gap.

## **Authentication at the Application Layer via Digital Signatures**

Current High-to-Low solutions for electronic mail have the capability for digital signatures to identify the originator of e-mail messages. These solutions also depend heavily on a mail guard for enclave boundary protection. Like SSL and IPSec, the enclave boundary protection system cannot perform the functions of inspecting the content of the message or verifying the digital signature if the message is encrypted. The currently available e-mail solutions allow the guard to decrypt a copy of outgoing messages in order to perform filtering on the contents of those messages.

Authentication at the application layer using digital signatures allows the enclave boundary protection system to determine the individual who is responsible for the traffic passing from High to Low, and then to make an access control decision to allow or disallow the traffic. Since the digital signature is based on public key cryptography, a public key infrastructure must be in place to enable this solution.

### **6.7.1.4.3 Processing, Filtering, and Blocking Technologies**

Solutions that logically fit within this solution category utilize various processing, filtering, and data blocking techniques in an attempt to provide data sanitization or separation between High network data/users and Low network data/users. Data originating from the High network is assumed to be High data though it may be asserted to be Low data by a High network user. Automated processing and filtering techniques may be performed by enclave boundary protection devices such as a guard, and if such tests are successfully passed, the data is actually regraded by automated means. In the reverse direction, such solutions often incorporate data blocking techniques (typically in firewalls but also in guards) to regulate the transfer of data from Low network users to High network users. Use of certain protocols may be blocked and/or data may be processed or filtered in an attempt to eliminate or identify viruses and other malicious code transfers.

The technology categories of data separation and authenticated parties do not allow users to use automated means to transfer data between the High and the Low network. The only technology that allows automated data regrading and transfer is processing, filtering, and blocking. Hence, this technology is the linchpin of High-to-Low. Without processing, filtering, and blocking techniques, there are no automated mechanisms supporting the regrading of information from High networks to Low networks. Data separation and authenticated parties technologies are restricted to allowing information transfer between networks only by means of human intervention such as retyping or optical scanning.

It must be emphasized that data transfer between High and Low involves risk, and one must take steps to mitigate risk. If data separation via a technology described in any of the other solution categories is not possible, then processing, filtering, and blocking must be considered. It must, however, be recognized by implementing organizations that these techniques involve inexact attempts to filter High data from outgoing transmission through content checking against a pre-defined list of prohibited strings. It also involves scanning for and detecting virus-infected executables, and blocking executables. Since there are an almost infinite number of possible executables, and malicious ones can be detected only through prior knowledge of their existence, the problem of detecting “maliciousness” in an arbitrary executable is not computable. This is exacerbated by the fact that there are many executables that users wish to allow to cross the network boundary (e.g., Java applets, Active X controls, JavaScript, Word macros) and that they would therefore not wish to filter out or block. Only by performing a detailed risk management tradeoff analysis wherein operational needs are weighed against security concerns can these issues be resolved.

## UNCLASSIFIED

Multi-Level Security  
IATF Release 3.1—September 2002

Solutions using processing, filtering, and blocking employ some type of processing to allow information flow between the two networks but attempt to detect and block attacks and High data leakage. Solutions here include—

- I-Server for Communication, Network Access, and Releasability.
- Mail Guard.
- Low-to-High Replication.

Each of these is discussed below.

### **I-Server for Communication, Network Access, and Releasability**

This solution uses a special purpose computer, dual-homed at the boundary between the High network and the Low network. The solution is identified as a technology gap due to the nonexistence of commercial products that have this capability. The technology needed to develop such products is well understood, however. The computer, called an *Intermediate Server*, is a remote host that users on the High network can log in to and execute browsers and Internet client software. The *I-server* is ideally a trusted computer with the ability to keep data of differing classifications separated. It also has the ability to protect itself against attack from the outside. Malicious code that might execute as part of Java applets or Active X controls would not be able to damage the I-server or the High network due to rigid design constraints.

The I-server is protected by a robust architecture that prevents tampering or modification of the operating system. This architecture also constrains the processes that are running any hostile executables to their own address space, and gives them no privileges to observe or modify files. The High network is protected by the remote location of the I-server, keeping potentially hostile code off of the High workstations and servers. Only the display of the information retrieved from the Low network is sent to the High network.

The specific capabilities addressed by this solution are communication, network access, and releasability. Communication is addressed by allowing the user on the High network to exchange electronic mail with users on the Low network, and to participate in Chat sessions with parties on the Low network. Network access is addressed by allowing users on the High network to perform WWW browsing via the I-server, and to access FTP servers on the Low network via the I-server. Releasability is addressed by allowing users on the High network to upload files to be released to the I-server, applying filters to determine that the information is indeed releasable, and then sending the released files to external servers.

The I-server architecture enables indirect accesses to the Low network. The I-server is a trusted computer that has MLS capability with high assurance. The I-server is connected both to the Low network and to the High network. Users on the High network log onto the I-server at the Low level. Browsers and other Internet clients, e.g., Simple Mail Transfer Protocol (SMTP), FTP, and Telnet, execute on the I-server, and all information retrieved from the Low network stays on the I-server at the Low level. That information can be viewed by the user on the High network who requested it. The viewing is done through a terminal emulation protocol between the I-server and the user workstation on the High network. Since the I-server is a trusted

computer that can protect itself from attack, the threat posed by malicious executables is greatly diminished.

The following are the steps a user would perform to browse the Low network from the High network through an I-server—

- Log in to the I-server at the Low level.
- Authenticate to the I-server via password or other authentication mechanism.
- Run the Web client available on the I-server.
- Type in the Universal Resource Locators (URL)/IP address desired or select from your personal set of bookmarks/favorites or select entries from an address book.
- See the responses through terminal emulation at the user's workstation and, if desired, save them on the I-server for future reference. Files saved on the I-server will be saved at the Low level.

Note that the steps above do not include a means for a user to pull data retrieved from the Low network to his or her workstation on the High network. Since pulling of data from the Low network could create an avenue for attack, the I-server prohibits this pulling. To allow this pulling of information through the I-server would bring along the inherent risks of pulling data from untrusted sources on the Low network. If pulling of data is a user requirement, then procedures and policies must be in place to mitigate risk of pulling hostile executables. One such policy would be to allow pulling of only ASCII text and to prohibit use of decoding software (such as UUdecode) on that text.

The main security weakness of the I-server is the potential for leakage of data from the workstation on the High network that is untrusted, to the Low process executing on behalf of the user on the I-server. This could occur through a covert channel in the terminal emulation protocol and be driven by a Trojan horse on the user's workstation. It would also require collusion at the receiving end (the Low process on the I-server). This vulnerability would be difficult to exploit, and therefore is considered lower risk than would be present if the HTTP protocol were being sent end-to-end between the workstation on the High network and the server on the Low network.

## **Mail Guard**

This solution is readily available with both commercial and government-developed products. The guard is deployed at the boundary of the High network and the Low network. The guard performs filtering and control of mail messages passing High to Low and Low to High. The filtering is based on the headers of the mail messages, e.g., sender, recipient, presence of signature; as well as the contents of the mail message, e.g., encryption of contents, presence of prohibited words or phrases. At this time the solution only addresses communication via electronic mail. Guards are typically used in conjunction with "authenticated parties"

technology. This adds some strength to the relative weakness of content filtering employed by a guard.

Current mail guards are very flexible, allowing implementation of a wide variety of message acceptance and message release policies. It is possible to configure mail guards to be very liberal in these policies. Policy makers must pay strict attention to policy decisions to assure that policies are not so liberal as to negate the usefulness of the mail guard.

## **Low-to-High Replication**

Low-to-High replication allows users on the High network to receive data that originates on the Low network, without having to explicitly request that the data be sent from the Low servers. Replication can be used for network access, pushing data from the Low network to the High network. It cannot be used for releasability or for communication, because its primary security property is the prevention of data flows from High to Low.

Replication can give the High network any application that passes messages from one host to another. Examples are database replication, FTP, electronic mail, and Web Push protocols.

To prevent data leakage from High to Low, replication does not allow a direct back channel to send message acknowledgements from the High network to the Low network. To do so would allow quite a large covert channel. The replication acts as an intermediary, sending acknowledgements to the Low sender, and receiving acknowledgements from the High recipient. The Low sender cannot determine with precision the timing of the acknowledgements sent from the High side. Hence, the bandwidth of the back channel is reduced by the intermediate buffer within the replication process. This disconnects any direct communication from High to Low.

Replication does not mitigate the potential risk that data replicated into the High network might be hostile executable code. Mitigation of this risk would require that data be replicated first in a network guard that inspects the data for potentially hostile code, making sure the data passes this inspection before being forwarded into the High network.

### **6.7.1.5 Requirements Cases**

This section is intended to address the connection of High-to-Low networks for purposes of communication, network access, and releasability. These are general, functional requirements that have been articulated by various customers. Presently, only the Secret-to-Unclassified network connection scenario has been analyzed in detail. There are other connection scenarios where similar requirements appear to be appropriate. The additional scenarios we are aware of are Top Secret-to-Compartmented-Top Secret, Top Secret-to-Secret, and Secret U.S.-to-Secret (Allied). These other scenarios are under analysis, and their requirements will be presented in future versions of the framework if they are found to be different from the Secret to Unclassified case.

## Case 1: Secret-to-Unclassified

Users on the Secret network have a need to connect to the Unclassified network for the purposes of communication, network access, and releasability. For communication, the needed application is electronic mail. Access to the Unclassified network is needed also via Web protocols, using commercially available Web browsers. Finally, Secret users sometimes create large files that are in reality Unclassified. In some cases users have a need to release these Unclassified files to the Unclassified network.

Electronic mail is currently enabled between Secret and Unclassified in many instances through a mail guard, which is sometimes coupled with a COTS firewall. In the Defense Message System, e-mail will be enabled between Secret and Unclassified using a mail guard. The immediate need is to develop the additional capability to use Web-based protocols (i.e., HTTP) to access Web servers on the Unclassified network. Another immediate need is to develop the capability to release large files from Secret to Unclassified (probably using FTP). Current guards do not have the capability to allow network access and releasability. The environmental requirements for the Secret-to-Unclassified connection include—

- Secret users must be able to use COTS software, e.g., browsers and e-mail clients, in accessing information, communicating with users, and releasing information on the Unclassified network.
- Secret users must be able to use the installed base of operating systems, whether they are Windows or Unix.

The new capabilities for access to the Unclassified network and for releasability must coexist with existing capabilities to send and receive e-mail with users on the Unclassified network.

## Case 2: Secret U.S.-to-Secret Allied

This section will be provided in a later release of the framework.

## Case 3: Top Secret-to-Secret

This section will be provided in a later release of the framework.

### 6.7.1.6 Framework Guidance

In this section, guidance is provided on the solutions that can be implemented now to perform High-to-Low network connections for the purposes of communication, network access, and releasability.

## Case 1: Secret-to-Unclassified

### *Requirement Considerations*

In order to place the framework guidance in a proper perspective, this section delineates the specific security requirements being addressed and discusses issues associated with providing solutions for them.

#### Communication

- Secret users must be able to send and receive Unclassified electronic mail with communication partners on the Unclassified network.  
*This requirement opens the possibility of leakage from Secret to Unclassified and also the possibility of attacks being encoded in messages received from the Unclassified network.*
- Secret users must get notice of electronic mail that was sent to users on the Unclassified network but could not be delivered, i.e., bounced messages.
- It must be possible to send and receive electronic mail with attachments.  
*Attachments greatly increase the risk of leakage Secret to Unclassified, and the risk of attack to the Secret network, because it is generally very difficult to determine whether an attachment contains an executable.*
- Secret users must be able to participate in live Chat sessions with users on the Unclassified network.
- Secret users must be able to use collaborative technologies such as whiteboarding and video conferencing with users on the Unclassified network.
- Internet Telephony between Secret network users and Unclassified network users must be enabled as the technology becomes available.

#### Releasability

- Enable Secret users on the Secret network to designate and push, e.g. FTP, e-mail, HTTP Post, etc., data to the Unclassified network that is releasable to users on the Unclassified network.
- Enable Unclassified users on the Unclassified network to access the released Unclassified data using Web technology and FTP database access techniques.
- Access to Unclassified data released from a Secret network may be restricted to specific Unclassified users, or groups of users, or may be made publicly available.
- The format of Unclassified data released from a Secret network may be text, video, images, audio, or executable software.

#### Network Access

- Secret users on the Secret network must be able to access the vast information resources on the Unclassified network using HTTP, FTP, Gopher, WAIS, SQL, or Web Push.
- When using Web Push as a result of a previous Secret user request to the Unclassified network, Unclassified information is pushed into the Secret network from the Unclassified network.  
*The implications of these requirements are the dangers in retrieving data from servers. Data could harbor malicious executables. Also, information normally transmitted using the HTTP protocol might give the Unclassified servers a passive intelligence gathering capability.*

Secret users must be able to use search engines that reside on the Unclassified network. This effectively means keywords must be sent from the Secret user to the Unclassified search engine.

*The main implication of this is that data must be transmitted from Secret to Unclassified via the HTTP Post method. This method allows arbitrary data to be posted to an HTTP server. Measures must be taken to assure that Secret data is not being posted to an Unclassified server.*

- The Secret client needs to receive data of arbitrary type and format.  
*This requirement increases the possibility of attack on the Secret client. The arbitrary format of the data makes it virtually impossible to detect any undesired executable.*
- Error conditions sent by Unclassified servers must be received by Secret clients.
- The WWW interface must generate error and warning messages when it is unable to fulfill the request of a Secret client, and the Secret client must receive these messages.

### ***Recommended Security Policies***

The security policy for the Secret-to-Unclassified connection must include statements requiring countermeasures for attacks described previously.

For passive attacks the security policy must address:

- **Traffic Analysis.** The guard shall include measures to make all network access requests coming from the Secret network anonymous.
- **Monitoring Plaintext.** Encryption shall be used for all electronic mail passed out of the Secret network. Encryption shall be used between the high workstations and all external hosts receiving data for releasability. Encryption shall be used with all Unclassified hosts that support it (for example, via SSL, IPSec). The minimum size of the encryption key shall be 80 bits.

For network-based attacks the security policy must address the following attacks:



## UNCLASSIFIED

Multi-Level Security  
IATF Release 3.1—September 2002

- **Modification or Insertion of Data in Transit.** All data in transit shall have either a digital signature or keyed hash algorithms applied. These cryptographic algorithms must be deployed in conjunction with timestamps or sequence numbers to prevent replay of valid data.
- **Insertion of Hostile Executables.** Scanning for viruses and blocking applets and other executables must be performed for all data being transmitted into the Secret network.
- **Defeating Authentication Mechanisms.** Strong cryptographic authentication must be used across the enclave boundary. No Unclassified users shall access the Secret network unless it is done in accordance with the framework guidance for remote access.
- **Session Hijacking.** Continuous authentication along with timestamps or sequence numbers shall be used to prevent session hijacking.
- **Establishment of Unauthorized Network Connections.** Policy shall prohibit connections between the Secret and the Unclassified network other than those providing adequate security countermeasures.
- **Masquerading.** E-mail sender authentication and authorization to release data or to access the Unclassified network shall be handled using digital signature.
- **Manipulation of Data on the Secret Network.** This shall be handled through blocking of executables, and authentication of any users on the Unclassified network that access the Secret network remotely.

The security policy to prevent insider attacks involves procedural, physical, and personnel security. The primary technical countermeasure is to implement audit and intrusion detection systems on the Secret network.

For development, production, and distribution attacks, the vendors of all commercial security products shall use approved configuration control techniques and approved distribution methods.

### *Recommended Topology*

The IATF recommends the topology shown in Figure 6.7-2 for the near-term Secret-to-Unclassified solution.

The figure shows that the only service offered between Secret and Unclassified is e-mail at this time. The guard enforces the policy for release of messages from the Secret user side. This policy can include content filtering, crypto-invocation check, release authority check, message format check, valid receiver check, message nonrepudiation signature, sequence signature, and allow/disallow attachments. The policy for admittance of messages to the Secret network can include all of these elements except crypto-invocation check. The guard will be able to decrypt copies of encrypted messages being released. However, if messages being admitted to the Secret network are encrypted, the guard will not be able to decrypt them. Consequently, the guard will not be able to filter incoming messages that are encrypted.

With minimal work, current mail guards can be modified to allow for releasability for Secret-to-Unclassified networks. It will take considerably more work to enable network access between Secret and Unclassified networks with adequate risk mitigation, because the risks of network access are quite high. The Technology Gaps section outlines a migration path to allow near term Secret-to-Unclassified capability for releasability and midterm capability for network access.

For the near term it is obvious that the guard will remain the linchpin of Secret-to-Unclassified connectivity. Many risks exist that guards will never be able to mitigate. The long-term architectural goals should be to minimize the number of Secret-to-Unclassified connections while working to migrate toward MLS on the desktop workstation and within the servers.

The optimal solution to minimize risk is to move away from Secret-to-Unclassified and move toward MLS. MLS could be implemented on the desktop using CMWs or the Starlight Interactive Link technologies. There are several medium assurance (B2-B3) platforms on the market that are now being used as guard platforms. These could be converted to use as server platforms. Data could be separated on the network cryptographically. The technology exists for MLS; the business case has been the problem. The MLS systems that have been developed by industry have met with a lukewarm reception by government customers. Only if the Government is serious about using MLS will MLS become available.

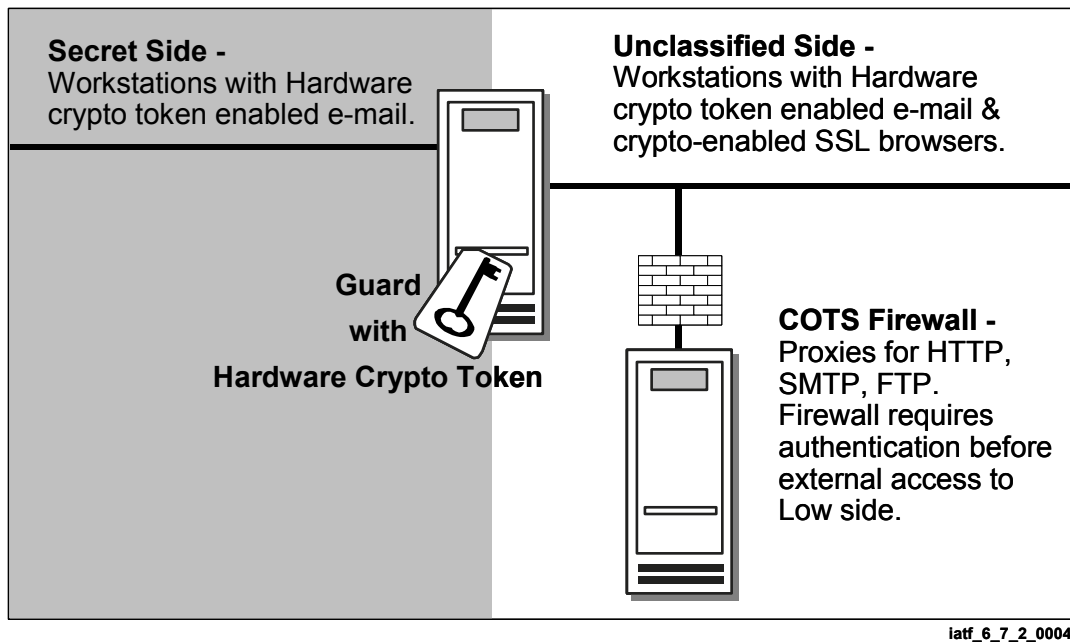

Figure 6.7-2. Recommended Topology

### *Technology Gaps*

This section addresses the near-term technology advances that should be addressed to allow Secret-to-Unclassified releasability, then the midterm advances for Secret-to-Unclassified network access.

## UNCLASSIFIED

Multi-Level Security  
IATF Release 3.1—September 2002

- a) **Technology Gaps for Communication.** The technology to allow Secret-to-Unclassified communication via electronic mail is readily available. However, the technology to allow Chat, whiteboarding, Internet telephony, and video conferencing across the network boundary is not yet available.
- b) **Technology Gaps for Releasability.** All of the capabilities needed to support releasability are currently technology gaps. However, it is felt that Secret-to-Unclassified releasability can be accomplished within 2 years using the present solution topology shown in Figure 6.7-2. The goal is to allow users on the Secret side to submit files to the guard for downgrading. Then those files should be stored on a releasability server on the Unclassified side, making them available to Unclassified side users. They could also be made available to users outside the firewall, with the firewall and the releasability server performing authentication and controlling dissemination.

This should be accomplished by developing a releasability policy for the guard and then applying the policy to files being mailed to the releasability server. The releasability policy would likely be different from the message release policy applied to regular e-mail. The guard would recognize e-mail destined for the releasability server and would apply the releasability policy. The releasability policy will be more restrictive than the message release policy in the following ways.

- Only a very small set of users on the Secret side shall be allowed to release files to the releasability server.
- The guard shall maintain a list of this set of users and check the list upon each submission of a file to be released.
- All files submitted for release require signatures by two of the authorized individuals; one is a nonrepudiation signature; the other is a sequence signature.
- Only files with specific formats of plain text or HTML shall be releasable.
- Strict audit logs shall be kept on the guard of all files sent to the releasability server.
- Released files shall be scanned for content.

The releasability server should be a COTS product that receives the files and stores them for future publication. Publication occurs when an authorized user on the releasability server unwraps the files from their signed MSP wrappers, and places them in a directory that is accessible to other users. The authorized user of the releasability server must set the appropriate permission on the published files to allow the intended users to access them.

- c) **Technology Gaps for Network Access.** There is considerably more work to be done for network access. A completely new set of filters and proxies must be developed for the guard to recognize HTTP, FTP, Gopher, WAIS, SQL, and Web Push protocols and to apply appropriate policies to these. Work is needed to develop these policies and vet

them to gain confidence that they adequately mitigate risk for network access. Elements of such a policy must include but not be limited to the following.

- HTTP Post is not allowed Secret-to-Unclassified.
- Certain fields within the HTTP protocol that identify the user making the request and the version of the browser being used must be set to arbitrary values, effectively making the Secret user anonymous.
- Executables must be blocked from entering the Secret network as Java applets or Active X controls.
- The guard shall maintain a list of URL to which access is authorized, and enforce the policy that these URLs are the only ones accessible. The guard shall perform stateful filtering of HTTP.
- The guard shall prohibit Secret users from using the FTP PUT command.
- The guard shall maintain a list of users on the Secret network that are allowed to perform network access and network access attempts using SSL.

## **Case 2: Secret U.S.-to-Secret Allied**

This section will be provided in a later release of the framework.

## **Case 3: Top Secret-to-Secret**

This section will be provided in a later release of the framework.

### **6.7.2 MLS Workstation**

This section will be provided in a later release of the framework.

### **6.7.3 MLS Servers**

This section will be provided in a later release of the framework.

### **6.7.4 MLS Network Components**

This section will be provided in a later release of the framework.

## UNCLASSIFIED

Multi-Level Security  
IATF Release 3.1—September 2002

### References

1. Reference: SSL 3.0 Specification, Netscape Communications.  
<http://home.netscape.com/eng/ssl3/index.html>.
2. Myong H. Kang, Ira S. Moskowitz, Daniel C. Lee. A Network Pump. Proceedings of the 1995 IEEE Symposium on Security and Privacy, pp 144-154. Oakland, CA.
3. Myong H. Kang, Ira S. Moskowitz, Bruce E. Montrose, James J. Parsonese. A Case Study of Two NRL Pump Prototypes. Proceedings of the 1996 ACSAC Conference. San Diego, CA.
4. Myong H. Kang, Judith N. Froscher, Ira S. Moskowitz. An Architecture for Multilevel Secure Interoperability. Proceedings of the 1997 ACSAC Conference. San Diego, CA.

## Chapter 7

# Defend the Computing Environment

Defense of the computing environment focuses on the use of information assurance (IA) technologies to ensure the availability, integrity, and privacy of user information as it enters, leaves, or resides on clients and servers. Clients are the end-user workstations, both desktop and laptop, including peripheral devices, whereas servers include application, network, Web, file, and communication servers. Applications running on clients and servers may include secure mail and Web browsing, file transfer, database, virus, auditing, and host-based intrusion detection systems (IDS) applications. Defending the computing hardware and software from attack may be the first line of defense against the malicious insider—or it may be the last line of defense against the outsider who penetrates the enclave boundary defenses. In either case, defending the computing environment is necessary to establish an adequate IA posture.

As illustrated in Figure 7-1, the computing environment may reside within a physically protected enclave, or it may be the host platform of a traveling user. The environment includes the host or server applications, operating system (OS), and client/server hardware. To date, the Defense-in-Depth technology strategy

has identified the need for secure applications and OS on clients and servers. These security technologies are addressed in Section 7.1, Security for System Applications. The secure applications considered are secure messaging, secure Web browsing, file protection, and mission-specific applications. Virus and intrusion detection software installed on host platforms is covered in Chapter 6, Defend the Enclave Boundary/External Connections.

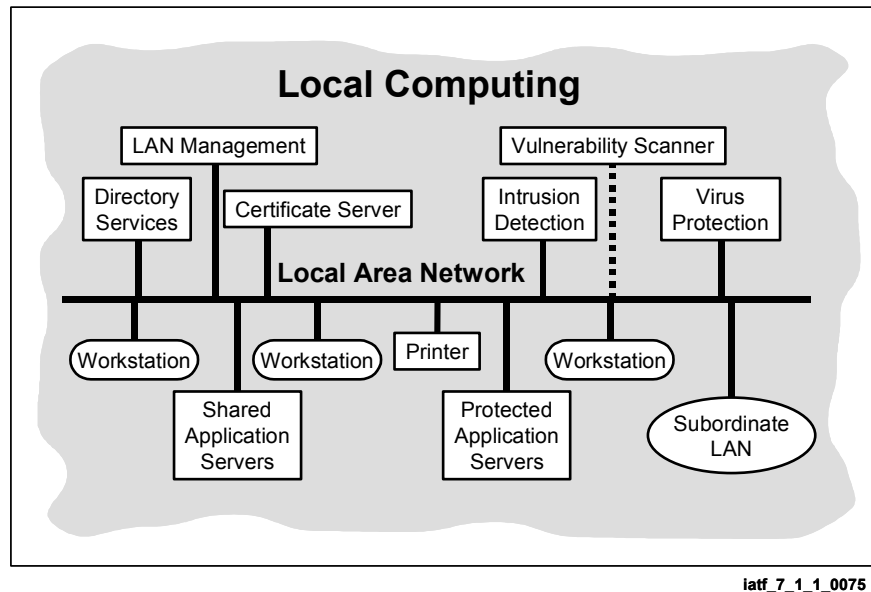

**Figure 7-1. Local Computing Environments**

**Security-Enabled Applications.** An application is any software written to run on a host; it may include portions of the OS. Although there are multiple strategies for security-enabled applications, this framework emphasizes the use of open standards and commercial off-the-shelf (COTS) solutions. The evolution of application programming interfaces (API) will simplify and

## UNCLASSIFIED

Defend the Computing Environment  
IATF Release 3.1—September 2002

improve the interoperability of the solutions and produce standards for use throughout the Government and the commercial community.

**Securable Operating System.** In general, the IA strategy is to provide a centrally managed, securable, and securely configured operating system foundation. The vast majority of a system's life occurs after it is initially configured. System administrators should employ tools to ensure that the initial configuration is secure, that only needed services are enabled, that vendor updates and patches are maintained, that subsequent changes maintain or improve security configuration, and that systems are checked regularly to ensure that the configuration remains secure.

**Host-Based Monitoring.** Host-based monitoring technologies include detection and eradication of malicious software like viruses; detection of software changes; checking of configuration changes; and audit, audit reduction, and audit report generation. Monitoring mechanisms include tools run by users, such as antivirus software, and tools managed by system administrators. For example, administrators use network and host-based vulnerability analysis tools to verify that vendor patches are installed, detect weak user passwords, and monitor for excessive use of user access privileges. Virus protection software should be used within local computing environments.

## 7.1 Security for System Applications

This section examines the security features and services that applications can or should provide, particularly with respect to the use of cryptography and good design practices. Several technology areas are considered:

- Network-to-network communication.
- Cryptographic security services and cryptographic application programming interfaces (CAPI) that provide generic encryption, key exchange, signature, and hash functions, or higher level security services for application developers.
- Executable content or software download, including software upgrade issues, e.g., firmware updates.
- Applications themselves that can be basic and relatively straightforward, taking advantage of security services for their functionality, or extremely complex, adapting basic functionality to meet a particular mission need.

In each technology area, the section describes specific security considerations and security and interoperability concerns. These include alternative technologies, protocols, and standards for interoperability that may be useful to those building complete and real systems.

This section generally follows the format established in other sections: target environment, consolidated requirements, potential attacks, potential countermeasures, technology assessment, cases, and guidance. The concerns for e-mail, distributed databases, file encryption, Internet phone, and Web-based applications have similarities but also differences because of use, technology, and standards. In the major sections, the common aspects of application-level security are considered. In the technology assessment section, additional, more application-specific information is supplied.

### 7.1.1 Target Environment

The environment for user- or application-layer security is generally considered to be a workstation (laptop, desktop, etc.) connected at least part of the time via a network to sensitive information servers. Additionally, the information on the servers (and on the workstation) may need protection even from other personnel or workstations privileged with access to network resources. Further, the section assumes that the environment is the “application space” where users and applications operate on information that has value. Physically, this environment applies anywhere within the Global Information Infrastructure (GII) that a particular application might send, store, retrieve, or destroy sensitive information. It typically embodies the elements of a three-tier model: the client, the business process, and the databases that serve a particular process.



### 7.1.1.1 Applications Environment

The environment for applications is considered to be a well-managed UNIX or Windows-based client/server OS, managed by knowledgeable system administrators, using security principles and practices in a documented networked environment, using all known system patches for security, and following good management practices to maintain a system information policy. Most applications will be commercial, i.e. the foundation will be commercial packages, but increasingly the application must be customized to fulfill a specific business process need. Customization may take many forms, and the coding language used by custom applications will affect the security of the resulting system. Highlights of these coding languages follow.

C and C++ are widely regarded as portable languages that allow applications to move across platforms. Compilation options and nonstandard terms may create debugging problems.

Common Gateway Interface (CGI), Practical Extraction and Report Language (PERL), JavaScript, Microsoft Macro Language, and similar scripting languages are very powerful, with cross-platform capabilities. Their power makes these languages good targets for hacking attacks, as they support both local and network capabilities.

Java is billed as cross-platform, but as with C and C++ great care must be used in writing actual code to ensure cross-platform capabilities. The Java language is somewhat unusual in having a security model (the sandbox), but the concept greatly limits the usefulness of some applications. Efforts to expand the sandbox are making Java more like ActiveX, providing more capability, though at greater risk, and with some user trust of the software provided through interfaces and signed code.

ActiveX is a Microsoft-unique language/capability for distributed custom applications. Though ActiveX is very powerful, the security model is fairly simple, based on signed code with authenticated signatures. Its flexibility is a concern to many security professionals.

There are other languages available, on various platforms, with other concerns. The four software applications considered in this section are generally assumed to be well-written code from developers lacking evil intent. The environment assumes that the vendor code functions as intended, without bugs.

### 7.1.1.2 Operating System Environment

This section of the framework is focused on the security services that applications could provide to protect data that the applications manage and manipulate on behalf of users. This data may be intended for private, narrowly shared, or widely shared consumption. Typically, an OS allows users to share hardware resources. The OS virtualizes and manages access to memory, disk drives, data ports, and other hardware resources. Its management separates users so that one user's memory space cannot be read by another user's process. The OS management also allows for portability, so that software code written on one machine may be ported to another machine with less difficulty than if all code directly called the hardware.

An OS provides several basic mechanisms to support information system and application security. The requirements for these mechanisms have been widely written about in the common operating environment (COE) requirements and in the Common Criteria (CC). A specific set of requirements for OSs is being captured in Common Criteria protection profile format through the Defense-wide Information Assurance Program (DIAP) to document requirements for protection of host computer OSs (clients and servers).

The OS environment should make it possible to securely identify and authenticate users of the system. Access controls and permission should be issued to all users of the operating system to ensure proper access to files and directories. The OS should also have an audit log, to provide security check points. An audit log can be used by system security administrators to backtrack system access if there is a security violation. The audit log itself must be well protected from unauthorized access and modification.

In selecting an OS, a risk assessment should be done to check vulnerabilities. This assessment can be especially necessary when an OS regularly receives patches. Failure to update patches regularly can leave an OS widely susceptible to hackers and other security breaches.

### **7.1.1.3 Standards and Protocols for Providing Security to System Applications**

Efforts at standardizing security features and services have attempted, as a primary goal, to specify algorithms, formats, protocols, configurations, etc. If there is standardization, the common security services (Section 4.4, Important Security Technologies) can protect against the universe of threats (Chapter 4, Technical Security Countermeasures) with maximum interoperability (Section 4.6, Interoperability Framework).

From an environment standpoint, the Information Assurance Technical Framework (IATF) emphasizes the importance of using open standards and COTS solutions. Commercial implementers are more and more dedicated to generating and using open standards that allow multiple independent implementations to interoperate. The security community is demanding public disclosure of the details of security protocols and algorithms so that these standards may be tested to an appropriate level of assurance.

## UNCLASSIFIED

Defend the Computing Environment  
IATF Release 3.1—September 2002

The term “standard” is used quite loosely in the IATF. It is meant to include any standard, or any technology or product initiative that could evolve into a standard. Standards can encompass national, international, Department of Defense (DoD), federal, allied, and commercial standards. This framework primarily addresses standards relating specifically to security but may also include other standards that affect interoperability or system infrastructure. Security is often simply an element of a broader standards activity.

Specific examples of standards and protocols of interest include the following (see also Section 4.4, Important Security Technologies).

- Application layer
  - Secure Hypertext Transfer Protocol (S-HTTP)
  - Object Management Group’s Common Object Request Broker Architecture (CORBA)
  - W3C XML Transfer Protocol
  - Secure File Transfer Protocol (S-FTP)
  - Secure Electronic Transactions (SET)
  - Message Security Protocol (MSP)
  - Secure/Multipurpose Internet Mail Extensions (S/MIME)
- Transport and network layer
  - Transport Layer Security (TLS)
  - Secure Sockets Layer (SSL ver 3.0)
  - Secure Shell (SSH)
  - Internet Protocol Layer Security (IPSec)
- Data link layer
  - Point-to-Point Protocol (PPP)
  - Serial Line Internet Protocol (SLIP)
- Security management infrastructure
  - Internet Engineering Task Force (IETF) Public Key Infrastructure (PKI)
  - IETF Simple Public Key Infrastructure (SPKI)
  - IETF Domain Name System Security (DNSSEC)
- Data labeling
  - National Institute of Standards and Technology (NIST) Federal Information Processing Standard (FIPS) 188 Standard Security Label
  - Institute of Electrical and Electronics Engineers (IEEE) 802.10g Secure Data Exchange (SDE) Security Label
  - IETF Internet Security Label
  - International Organization of Standardization (ISO) SC-32 Security Label
  - Military Standard (MIL STD) 2045-48501 (Common Security Label)
  - SDN.801 Reference Security Label
  - ISO MHS X.411 Security Label.

## 7.1.2 Consolidated Requirements

Security requirements for applications can be divided into two areas: functionality and assurance. The application security functionality requirements are simply a list of the security functions the application must supply if the information on the system is to be protected. Functionality requirements can usually be specified and tested objectively. The functional requirements for application layer software are broad—and range from local applications to all the many different approaches to communication and collaboration between users. The difficult question is where the requirements should be levied, in the OS or the application program. Common, widely used functions, such as file system access control, belong in the OS, specialized functions, are in applications. High-level functional requirements include the following:

- The application must be user-friendly, with well-documented user interfaces.
- The application must use correct and efficient backend processing.
- The application must support standards and implementation with standards-based API.
- The application must protect the privacy and integrity of user and system data.
- The application must authenticate the user to assign accountability.
- The application must generate a log of user activity for administrative monitoring purposes.

Management of configuration information should be centralized where possible and supported by secure remote management when necessary.

Assurance is a more subjective requirement. Assurance is a measure of confidence that the security features and architecture of an information system accurately mediate and enforce the security policy. Assurance requirements provide confidence that an application meets its security goals.

There are many different approaches to assurance. Process assurance requires the software developer to adhere to a specified software-engineering life cycle. Product evaluation assesses the design and realization of a product before approving it for use. Assurance provides increased confidence in the “goodness” of a product’s security features.

The National Information Assurance Partnership (NIAP), a U.S. Government initiative, intended to foster the availability of objective measures and test methods for evaluating the quality of information technology (IT) security products and accreditation of laboratories that can provide evaluation and validation services. In the United States, NIAP-accredited facilities contract with application developers to evaluate security products using methods and standards dictated in the Common Evaluation Methodology (CEM) for IT Security and the CC.

NIAP ensures that products meet the requirements and assurance levels proposed in security targets or a protection profile. Therefore, NIAP's duties are as follows:

- Evaluate application (using a standard, mutually agreed-upon process for reusable results—i.e., CC).
- Produce and monitor product evaluation test reports.
- Award NIAP-approved EAL certificate.
- Maintain lists of products evaluated.
- Standardized testing criteria and procedures.

## 7.1.3 Potential Attacks

The four classes of attacks are active, passive, insider, and distribution. These classes are a concern for security-enabled applications. Specific attacks, once identified will fall into one of these attack categories and can only be countered at a lower design level. Details of these attacks to application security are provided here.

### 7.1.3.1 Active Attacks

Protocol exchanges between clients and servers are common in application security. These protocols may have security as their immediate concern (authentication protocols) or they may provide application functionality, with the assumption that security is already in place. Many forms of spoofing and network connection hijacking have been observed; vulnerabilities have been identified in security protocols that were widely believed to be correct.

### 7.1.3.2 Passive Attacks

Passive attacks can vary greatly. Information collected may be clear-text or encrypted. Encrypted information may later be subjected to crypto analysis. Information passively captured may be used to support network replay attacks.

### **7.1.3.3 Insider Attacks**

Attacks launched by trusted users inside an enclave are considered insider attacks. Insiders may be employees, contractors, service providers, or anyone else with legitimate access to a system. A cleared insider is a person who holds a clearance and has physical or administrative access to classified automated information system (AIS).

Protecting against and detecting malicious behavior by insiders is one of the most difficult IA challenges. Both technical and procedural countermeasures can reduce the risk, but to be effective technology and procedures must complement one another. Countermeasures to this form of attack include enhanced background checks, physical security, and limiting each individual's authorized privileges. The application and the security features it provides can also partly counter these threats with features such as audit, two-person administrative requirements, and covert access prevention and detection.

### **7.1.3.4 Distribution Attacks**

Because the risk of malicious code in commercial application software is difficult to quantify, it is difficult to judge the value of countermeasures. For mass-produced office application software, which can be obtained from many sources, the risk of malicious software hidden in applications must be considered. For custom applications created for security-conscious organizations, the malicious software risk may be addressed in the design and development of the software. Defensive options include review and control of the source code and security requirements on the software development process.

### **7.1.3.5 Lower Level Attack Analysis**

Poor protocol specifications may enable lower level attacks. Careful analysis of the specifications of protocols such as Transmission Control Protocol (TCP) and Server Message Block (SMB) can identify opportunities for attacks that compromise information or deny service. For instance, the draft SMB protocol specification includes its security limitations.

Beyond the protocol specification, specific implementations can enable attacks. For example, some implementations that use a simple predictable algorithm to generate initial sequence numbers are susceptible to a well-known spoofing attack.

Another common group of lower level attacks exploits the failure of application code to do memory bound checks or other error analysis on data provided by external sources. Buffer overflows and other tricks can then be used to cause malicious remote command execution.

## 7.1.4 Potential Countermeasures

Because information systems can be susceptible to attacks at many levels, countermeasures must span a similar range. Some apply to the entire system. Some are application specific. At the most basic level some must respond to implementation-specific attacks.

Countermeasures must continually be improved to counter more sophisticated attacks. The ultimate goal is for the countermeasure to become so sophisticated that the cost of mounting the attack exceeds its potential value if successful: The threat to an information system is reduced when the rational attacker discovers the reward does not warrant the effort of the attack.

Countermeasures are enabled through various security mechanisms, such as cryptography. Cryptographic mechanisms include public key certificates, key exchange (public key cryptography), data encryption (private key cryptography), digital signatures, and secure hashing. Chapter 8, Supporting Infrastructures, is devoted entirely to supplying keys and certificates for cryptographic mechanisms and the infrastructure for managing keys and certificates. The chapter deals with PKI/certificate management infrastructures (CMI), and security management infrastructures (SMI) and the capabilities, security considerations, and policy that pertain to them. Functionally, PKI, CMI, and SMI are intended to authenticate that a certificate is tied to a unique entity, secure distribution of certificates and private key material, wide distribution of public key material, and notification of compromised and revoked certificates or key material. Technical and policy measures that counter attacks and security concerns related to key management are detailed in Chapter 8.

Details of security services and the countermeasures they provide are described in the following sections.

### 7.1.4.1 Access Control

Access control is the process of granting access to information and information systems only to authorized users, programs, processes, or other systems. Access can be controlled by identification and allotted roles, roles alone, user name, group membership, or other information known to the system. A well-managed Windows or UNIX OS can provide basic access control that limits user access to specific resources and privileges.

Controlling access to system resources, such as one of its applications, protects the data associated with the resource. Those who intend to alter the resource's information or add a malicious process are foiled because they are denied access to that data by the OS. It is particularly important to control who may enable or disable (turn on or turn off) the security features that may be built into the application or change programs or the privileges of users.

Secure applications that process data must be aware of their role in managing access to that data. That includes knowing who is attempting access, mediating access according to processing rules, auditing user actions, and managing where (access to printers in particular locations) or how (encrypted channels like SSL) data is sent. Access control may be managed solely by the

application, or it may use OS functionality for assistance, as when a database uses OS controls on files (user/group/world read/write privilege) by putting different classes of information into different files with different access privileges, with the users directly accessing none of the data.

### **7.1.4.2 Identification and Authentication**

Identification and authentication (I&A) is the process of identifying and authenticating the identity of the user who is trying to access a system, thus providing accountability. When I&A is used with effective access control, the more uniquely the user can be identified and the more assuredly this identity can be authenticated, the more secure the system.

Identity can be assured by requiring the user to show something he or she has (e.g., an identification badge or a hardware token). That identity can be authenticated by requiring the user to provide something he or she alone knows, (e.g., a password or personal identification number [PIN]) and something uniquely his or hers (e.g., a fingerprint, retinal scan, or other biometric).

Electronic or digital signature can also authenticate users. A public key certificate—an electronic certificate signed by an issuer—that can provide a unique digital identity for the holder of the certificate. Validating the certificate chain is part of the authentication process. The certificate issuer authenticates the identity based on possession of the certificate issued.

### **7.1.4.3 Data Integrity**

Data integrity means that data is maintained as intended and has not been exposed to accidental or malicious modification. Data integrity is separate from data encryption, although some encryption algorithms can be used to prove that integrity has been maintained.

An OS and an application can work together to protect data from modification. The OS can provide integrity on its files; they can be saved, opened, modified, and closed by applications with the assurance from the OS that the information on the files is changed only if an authorized application made the changes.

The application and the OS can provide additional integrity through use of a secure hash function: Each entry is mathematically hashed, producing a unique value for that entry. Verification of the hash guarantees integrity of the data. A digital signature applied to the hash value authenticates the hash value and who applied it. It is important to note that hashing is a one-way function; the hashing algorithm cannot be reversed to reconstruct the data from the hash value.

### **7.1.4.4 Data Confidentiality**

Data confidentiality means that information is not disclosed to unauthorized entities or processes. Access control mechanisms support data confidentiality in information systems by controlling access to the system's resources.



Confidentiality is especially important when the application is not running. Without the OS or application controlling access, data in storage is especially vulnerable, as is data in transit, outside the direct influence of its generating application. Encryption is useful in both cases. Both applications and OSs can encrypt stored data and data in transit. Data confidentiality is directly related to the algorithm used to encrypt data and the protection of the key used for encryption.

## 7.1.4.5 Availability

Availability means that the adversary does not deny the access and processing of data to authorized users. Data that is inaccessible might as well not be there. Likewise, applications that fail to work are useless. The OS and applications should be designed to withstand failure in either the OS or an application. Most UNIX systems and Windows-based systems have error handling routines and fault isolation, making the OS more available if there is an application failure. Applications should be designed and tested to ensure that they do not fail, particularly under extreme conditions—the robustness of an application cannot prevent problems when the underlying OS or external network components (guards, firewalls, routers, cable) fail.

## 7.1.4.6 Nonrepudiation

Nonrepudiation means that the recipient is assured of the originator's identity and the originator is provided with proof of delivery, so that neither can later deny having processed the data. Nonrepudiation counters man-in-the-middle and spoofing attacks.

One way to achieve nonrepudiation is with digital signatures and auditing. Before transmitting, the originator signs the data with an algorithm that incorporates parameters unique to the originator. Verifying this signature verifies the originator's identity. Auditing makes a complete record that can serve as evidence and protects the record's integrity. For proof of delivery, the originator when sending data requests a signed receipt. The recipient signs it with an algorithm that incorporates parameters unique to the recipient. Verifying this signature verifies the recipient who received the data.

Since nonrepudiation often depends on an identity contained in a public key certificate, which can become invalid, it is important that a trusted third party be able to validate the certificate. It must be possible to prove the validity of the certificate at the time of the original communication, and the authentication must be recorded in the audit trail.

## 7.1.4.7 Auditing

Both the application and the OS can audit certain actions taken by users and software acting on the OS. An application might track when a user enters data into a database and information related to the data or its position in the database. An OS might track which users initiate a process or attempt to access certain files. Auditing is primarily an after-the-fact activity that supports information forensics activities and intrusion detection. To detect intrusions into a

computer or network, tools are available to observe security logs or audit data. These tools can be integrated into either the OS or the application, or can be separate software added to a system. See Chapter 6, Defend the Enclave Boundary/External Connections, and Section 7.2 for an in-depth discussion of intrusion detection.

Auditing is a protective measure only in the sense that knowledge that there is auditing may deter some threats to information systems. Auditing is much more useful in detecting questionable activity and reacting to such activities.

Applications developers should make explicit use of OS audit capabilities and plan for the use of the audit data by system administrators or other security professionals. One of the overarching technology gaps today is the lack of useful audit tools.

## 7.1.5 Technology Assessment

Three technology areas—cryptographic security services, applications, software download, software update, and biometrics—will be considered separately.

### 7.1.5.1 Cryptographic Security Services

If applications are to use cryptographic security services, first some type of cryptographic algorithm must be available. This framework will assess, not specific algorithms, but the medium, the token, on which an algorithm is presented to the application for use. The algorithm on the token is presented through a CAPI.

#### 7.1.5.1.1 Cryptographic Tokens

Stand-alone cryptographic devices met the security needs of the past. Confidentiality was the security service of choice; it was implemented with link encryption, with one device servicing many users.

The need for security services beyond confidentiality has arisen with the growth of network technology. One such needed service is I&A—the need to specifically name users and have assurance that the persons associated with those names are who they claim to be. As cryptographic technology has progressed in both size and cost, it can now provide personal security services. Each user can have a cryptographic device (security token) that is uniquely his or her own. Tokens can also provide data integrity and nonrepudiation services through hashing and digital signature algorithms.

Using a personal security token that implements public key cryptography enables each user to have a unique private key that can be used as the basis for the security services of nonrepudiation and I&A. One way to accomplish this is to use the keys to create digital signatures on messages. The recipient of such a signed message can verify the digital signature before accepting that the message is truly from the user who claimed to send it. Tokens can come in different

forms—from Personal Computer Memory Card International Association (PCMCIA) cards to smart cards and even software. Each offers advantages and disadvantages.

**PCMCIA Tokens.** A PCMCIA security token can offer a full suite of portable security services. Board real estate allows room for sizable RAM and electrically erasable programmable read only memory (EEPROM) or Flash EEPROM, providing ample memory for complex or multifunction firmware and certificate storage. Since it is a hardware token, the PCMCIA card can also protect secret values reasonably well and still leave room for additional physical tamper-protection mechanisms. On the downside, PCMCIA cards require PCMCIA card readers, which, although they are prevalent in laptop computers, are not common in desktop computers. The added expense of a card reader for every desktop workstation is definitely a disadvantage of the PCMCIA token.

**Smart Cards.** The smart card offers the same portability as the PCMCIA token at less cost. These cards still require special readers but the readers are much less complex than PCMCIA readers and therefore less expensive. Some manufacturers are incorporating smart card readers into their computer keyboards.

One significant concern with smart cards is data throughput. The defined interface is just too slow to support confidentiality services for any but the least demanding applications. Confidentiality would normally be relegated to software running on the workstation, which can reduce the assurance of this service; I&A, nonrepudiation, and data integrity would remain in the hardware on the smart card.

**Software Tokens.** Software tokens are the cheapest but also the least assured solution. Their implementation in software allows for quick distribution, ease of updating, and responsiveness to the needs of most users without the need for special hardware. When the security solution calls for minimal assurance and when cost is a major consideration, software tokens could be the answer.

There is a price to be paid with software, though: Software tokens will execute on untrusted workstations running untrusted OSs that make them ultimately vulnerable to bypass, modification, or even replacement. Systems that process highly sensitive information should not rely solely on software tokens security.

### 7.1.5.1.2 Cryptographic Application Programming Interfaces

As application developers become aware of the need for cryptographic protection, they add “hooks” to access cryptographic functions developed by others. These hooks at the lowest level (sometimes crossing into the OS and almost always within what would be called middleware) are the CAPIs. As CAPIs become more sophisticated, their value increases. Applications that use a standard CAPI can access multiple cryptographic implementations through a single interface. This helps to minimize life-cycle implementation efforts, and cryptographic modules built to a standard CAPI can be accessed by a greater number of applications, increasing reusability.

The numerous current efforts to create CAPI standards range from the very basic, like that found in Generic Security Services (GSS)-API, to those more directly controlling the cryptographic token, like Public Key Cryptographic Standards (PKCS) #11, and increasingly applications and cryptographic modules are being written to use certain CAPIs. While a single standard usable by all applications would be ideal, multiple CAPIs are required to support the broadest range of applications and cryptographic modules.

CAPIs are intended to provide these features—

- Interface between cryptography and applications
  - Facilitate the development of new security-enabled applications
  - Minimize cryptography processing by the application
- Application independence—support a broad range of application types: store and forward and connectionless.
- Module independence—support the entire range of hardware and software tokens.
- Algorithm independence—support a broad range of current and future algorithms.
- Functional completeness
  - Provide comprehensive security services
  - Facilitate cryptography export policy.

**High Level: GSS-API.** The GSS-API and the extensions for independent data unit protection (IDUP) support applications that do not interface with cryptographic services. These Microsoft security service providers (SSAPI) provide a high-level interface to authentication, integrity, confidentiality, and nonrepudiation (IDUP-only) services. The application merely indicates the required security services and optionally the quality of protection (QOP) for the per-message services.

GSS-API was designed to protect session-style communications like File Transfer Protocol (FTP) between entities. IDUP-GSS-API does not assume real-time communications between sender and recipient. It protects each data unit, whether file or message, independently of all others. IDUP-GSS-API is therefore suitable for protecting data in store-and-forward applications. The specifications for it were developed within the Common Authentication Technology (CAT) group within the Internet Engineering Task Force.

**Mid-Level: CDSA, MS SSAPI.** The Common Security Services Manager API (CSSM-API) is the heart of the common data security architecture (CDSA). CSSM-API offers a robust set of security services, among them cryptography, certificate management, trust policy, data storage, and optional key recovery. CSSM-API can support auditing services and provide integrity services via the Embedded Integrity Services Library (EISL).

CSSM-API, developed at Intel Architecture Labs, is approved as a standard within the Security Program Group (SPG) of the Open Group (the result of the X/OPEN and the Open Software Foundation merger). While such CSSM services as certificating management, trusting policy,

## UNCLASSIFIED

Defend the Computing Environment  
IATF Release 3.1—September 2002

and data storage fit logically at the middle level, the actual CAPI calls (their cryptographic service provider interface [SPI]) are more low level, like Cryptoki. For instance, CSSM-SPI supports user authentication and administrative control of tokens.

SSAPI is modeled after the GSS-API, though with more of a Windows style. It provides mutual authentication, message privacy, and message authentication because it is connection oriented, it is used for protocols defined by Microsoft as “SChannel”—SSL and WinPCT. It also supports NTLM, DPA, and Kerberos.

**Low-Level: Cryptoki (PKCS-11), Cryptographic API (CryptoAPI), Cryptographic Interface (CI) Library.** PKCS #11–Cryptoki is an OS-independent abstract token interface that defines the arguments and results of various algorithms. Cryptoki also specifies certain objects and data structures that the token makes available to the application; it interfaces directly to cryptographic tokens and is thus the logical place for functions that allow user authentication (e.g., logon or PIN entry) and administrative control of the token. Cryptoki, developed by RSA Labs and a member of their family of PKCS, is appropriate for use by developers of cryptographic devices and libraries. PKCS #11 workshops sponsored annually by RSA Labs for all interested parties contribute to the continuing development of Cryptoki.

As a service suite provided by the Windows NT OS, CryptoAPI provides extensive facilities for both hardware and software cryptographic modules, called cryptographic service providers (CSP). CryptoAPI has not been subjected to any formal standards process, but the authors at Microsoft did consult with various government and corporate customers. Applications using CryptoAPI can take advantage of default features of the interface to reduce their cryptographic awareness requirements, or they can exert full control over algorithms, keys, and modes of operation. Tables 7.1-1 to 7.1-3 depict specific pros and cons for GSS-API, CDSA, and Cryptoki:

The FORTEZZA<sup>®</sup> CI Library was initially the interface between the FORTEZZA PCMCIA card and applications wishing to use the security features associated with the National Security Agency’s (NSA) Multilevel Information Systems Security Initiative (MISSI) program. The CI Library is now being adapted for both smart card and software token implementations of FORTEZZA.

**Table 7.1-1. Pros and Cons of GSS-API**

<b>Advantages</b>	<b>Disadvantages</b>
Abstracts the lower level details of such services as cryptographic routines and key management.	GSS-API services must be implemented for each technology (e.g., Kerberos, Cryptoki).
Is platform independent—written with low-level programming languages (C/C++) as well as platform-independent languages (Java).	Complicated implementations require experienced developers to reduce the learning curve.
Is constantly being updated to match changes in technology.	
Is flexible enough to allow for addition of current technologies, such as PKCS #11.	

**Table 7.1-2. Pros and Cons of CDSA**

<b>Advantages</b>	<b>Disadvantages</b>
CSSM provides an “all in one” interface to security services (privacy, authentication, integrity, and non-repudiation).	It requires lower-level work to be done by plug-in modules. There must be trust that these modules are implemented correctly.
It is expandable to future CAPI implementations via the elective module manager.	Support is provided, not by Intel, but by the Open Group—mostly users, not developers.
It is designed specifically to deal with network operability and security solutions.	It is complicated to implement solutions.
APIs allow for hardware tokens, software modules, and hybrids of the two.	
It calls mimic security calls from previous non-standard implementations, allowing easier transition from nonstandard APIs.	
It has already implemented a PKCS #11 layer.	

**Table 7.1-3. Pros and Cons of Cryptoki (PKCS #11)**

<b>Advantages</b>	<b>Disadvantages</b>
Allows use of broad range of token-based devices (hardware and software).	As a stand-alone application, allows only for peer-to-peer security service.
Is compatible with middle and high-level APIs, such as CDSA and GSS-API.	Requires a user to log in for communication between software and token device—there is no built-in key infrastructure.
Interface is intuitive object-oriented (OO): public and private objects with attributes and methods, allowing easy modeling within such popular low-level OO programming languages as C++ and Java.	Requires token manufacturers to conform to the PKCS #11 standard.
Is compatible with different key types (RSA, DSA, Diffie-Hellman, RC2, RC4, DES).	

## 7.1.5.2 Applications

Applications are generally useful for exchanging information among many people within a specific system, or between information systems. The applications discussed here are “mission” applications; the basic functionality has been adapted to meet a particular mission need. Examples include databases, collaborative computing applications, and electronic commerce systems. Because information is being transmitted, the need for standard, interoperable, and secure applications is critical. While many applications are mature, most do not support the broad range of security services.

### 7.1.5.2.1 Mission-Specific Applications

Mission-specific applications can be as simple as a database making its data available through a fronting web server. They can be as complex as a complete travel service that checks and books airline, hotel, and rental car reservations through a Web browser; passes the information to the user via e-mail; and keeps the whole system secure with file encryption. These systems typically rely on existing COTS products, such as Web servers and clients and database management systems. As security is only one of many factors in the selection of such products, many desirable security features may not be present. In addition, legacy systems with very little security must often be included as part of the solution.

For mission-specific applications, which must enforce a definition of security unique to the application and the circumstances of its use, the security challenge is to combine many less-than-ideal generic component-level security services into a cohesive, meaningful application-level definition. This is a significant information system security engineering task.

Mission applications are often custom built in several distinct tiers. The three-tier model typically has a presentation layer, a business process layer, and a database layer. A conventional client/server system uses a two-tier approach. A system can have multiple separate application layers creating multiple tiers (see Figure 7.1-1). Collectively these systems are referred to as “n”-tier systems. Different systems will place different numbers of layers between the user and the data, and some may simultaneously support multiple paths to access data. There are many ways in which a mission application can be secured using readily available technology. Some of these enable the construction of new security-enabled systems. Others allow security to be retrofitted to existing systems or components. All are extensions of the security provided by the various system components.

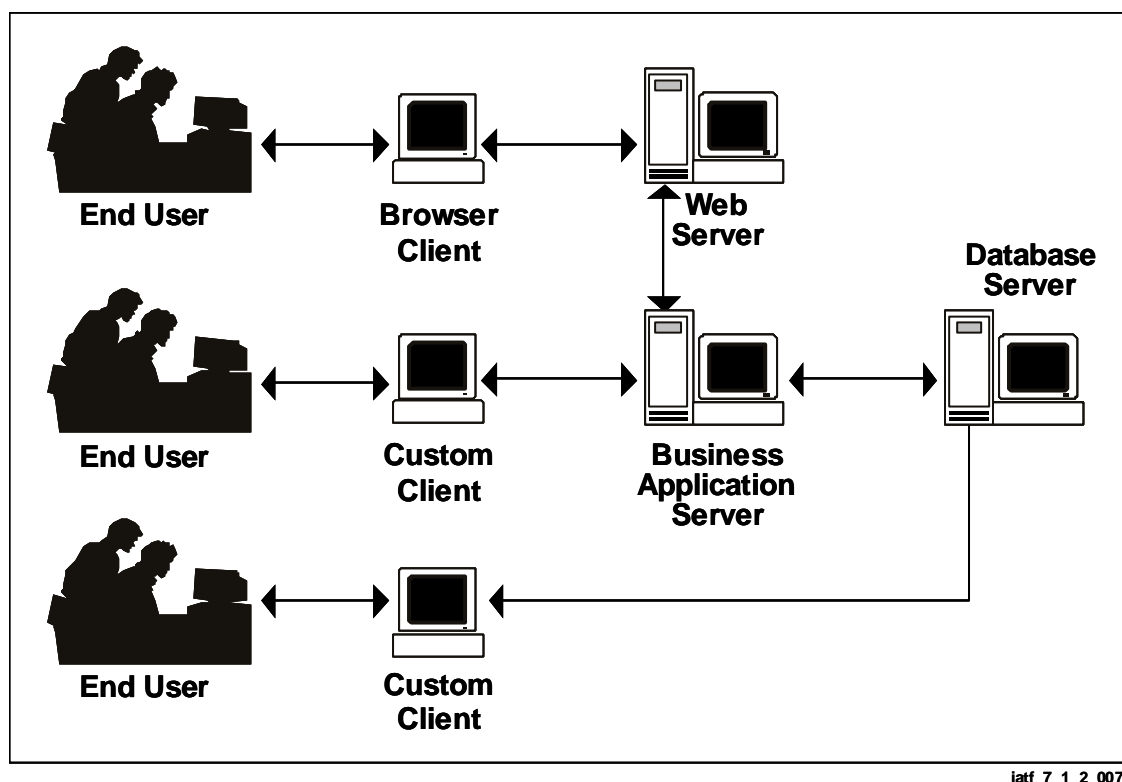

Figure 7.1-1. Custom N-Tier Applications

### 7.1.5.2.2 File Protection

File encryptors protect information in the computer if there is unauthorized physical access by encrypting the stored information. There are two basic types of file encryptors: one in which the user selects specific files to encrypt and one that automatically encrypts all information that is not currently being processed. The former can be used to securely transfer files as attachments or to protect critical information stored on floppy disk, CD, or a user's system. The latter are often referred to as media encryptors.

Media encryptors encrypt the entire contents of the drive except for some system files that must be left unencrypted so that the computer can boot. The integrity of most of these system files can be protected by a cryptographic checksum; this will not prevent a tamper attack, but it will alert the user that the data has been altered. Some system files, however, contain data that changes when the computer is booted. These files cannot be protected at all. The mechanisms implemented by media encryptors provide—

- Encryption of system files.
- Integrity of the contents of the data storage media.
- Confidentiality of the contents of the data storage media.



## UNCLASSIFIED

Defend the Computing Environment  
IATF Release 3.1—September 2002

- Integrity of the workstation, verifying the basic input/output system (BIOS) and ensuring that configuration and program files are not modified.
- Recovery of data if the original user can no longer access the media.
- Key management support: key generation, distribution, deletion, destruction, and revocation.

File encryptors typically implement a GUI that allows users to choose files to be encrypted or decrypted. This protects individual files but not all the files on the drive. The mechanisms implemented by file encryptors provide:

- Encryption of selected files.
- Integrity of the contents of the protected file.
- Confidentiality of the contents of the protected file.
- Authentication of a file's source.
- Exchange of encrypted files between computers.
- Recovery of data if the original user can no longer access the file.
- Key management support: i.e., Key generation, distribution, deletion, destruction, and revocation.

Many applications generate temporary files that may contain user data. These files are normally erased when the application is closed, but when the application does not close in an orderly fashion, these temporary files may remain. Some OSs do not actually erase data when files are deleted; instead, they alter the name of the file in the file allocation table. The user's data remains on the hard drive until the space is reallocated to another file and overwritten. Thus, after system shutdown, unencrypted and potentially classified user data can remain on the hard drive, because of either failure to erase temporary files or the design of the OS's erasing function.

The Range of possible architectures for the KMI/PKI needed to support file protection is wide. Possibilities range from a user having complete control over key generation and distribution to a hierarchical architecture involving a complex certificate authority (CA). KMI/PKI is discussed in detail in Chapter 8, Supporting Infrastructures.

### 7.1.5.3 Software Download

Planning for the secure update or download of software must begin early in development and continue throughout deployment. Three types of software download will be considered: firmware updates, software updates, and new software distribution. In all cases, the most critical aspects of downloads are the integrity of the downloaded software and authentication of the origin of the software. Sometimes confidentiality of the download may be required. Validity

periods, usage limitations, effects of the download on system data, and auditing of the download installation may also be important.

### **7.1.5.3.1 Firmware**

The key to managing firmware updates, exemplified by a recent update of modem software to support a new 56k standard, is planning for the hardware's ability to support that update: That hardware's ability must verify the integrity and authenticity of the firmware originator and the originator's associated firmware.. Because firmware is being updated, it can generally (but not always) be assumed that the firmware will be processed by the hardware during installation. In general, hardware processing is preferred over software processing because hardware is faster and has greater resistance to tampering.

Planning for a firmware update must begin with initial product development. Steps that must be taken during initial product development include the following:

- Decide what security services firmware update requires.
- Choose mechanisms to implement chosen security services.
- Confidentiality or integrity services may use a cryptographic mechanism.
- Cryptographic mechanisms include symmetric and asymmetric encryption.
- Determine whether symmetric or asymmetric cryptography will be used.
- If asymmetric encryption, generate a public/private key.
- Make the public key information readily available.
- If symmetric encryption, generate and store symmetric key material and determine secure distribution process to the user base see section 8.1.
- Field the initial product.

Updating the fielded product requires the firmware developer to take the following steps:

- Generate the code that updates the previously installed firmware.
- Cryptographically hash the updating software.
- Sign the hash with the appropriate keying material.
- Encrypt the package (software, hash, and signature).
- Distribute the package.

The deployed system user should then use the appropriate keying material to verify the signature and integrity of the firmware update. Then install the update package. Update status to include failures of the signature or integrity of the firmware update should be reported through a host user interface.

**Integrity**—Package integrity is provided by cryptographically hashing its contents. See section 7.1.5.4, Software Update for more detail.

**Authenticated Origin**—Signing the hash provides proof of origin; the private aspect of the public/private key pair must be appropriately protected. See section 7.1.5.4, Software Update for more detail.

**Confidentiality**—Encrypting provides confidentiality to the firmware updates. It is more efficient to use symmetric cryptography to support confidentiality mechanism and asymmetric cryptography to support key distribution for the symmetric cryptography. The user's public/private key pair creates a single-use private symmetric key for each download. See section 7.1.5.4, Software Update for more detail.

**Other Security Services**—Other security services can be provided by hardcoding information in the initial package or including information for processing in the package. For example, limiting use of an object to a specific time period could be handled by validity dates on the signature, coding in the object broker to allow a fixed period of use on each download. In all cases it is important to keep the security objective in mind and to manage a chain of trust till that objective is achieved.

## 7.1.5.4 Software Update

Developers distribute modifications to software that already resides on a system. These modifications include service updates to software packages such as Windows or Microsoft Office and distribution of active content code (e.g., Java, ActiveX, objects in Distributed Component Object Model [DCOM] or CORBA, macros, etc.). During the download some known trusted piece is already in place to verify the security.

Software updates and active code distribution are managed much like firmware updates, except that software updates may not be able to rely on hardware storage of key material, so the level of assurance is likely lower than with firmware updates. For most active content, there is a virtual machine (e.g., Java Sandbox or macro interpreter) limiting or at least managing the operation of the active code.

### 7.1.5.4.1 New Software Distribution

New software is best distributed on media that are hard to modify like CD-ROMS, in tamper-resistant packaging with unique vendor identification, like holographic labels, which are widely used by commercial vendors to prevent fraud. Some software distributions include side programs to verify authenticity of the package, or are self-checking. However, since anyone can write code that appears to verify or self-check other code, these mechanisms are not particularly useful.

## 7.1.5.5 Biometrics

Biometrics is an authentication mechanism to support access control. A truly automated biometrics system should be able to discern a user at any terminal. The associated authorization service determines the correct access and monitors to ensure that only the authorized user accesses the information or information system. Access controls are policies or procedures establish criteria for system access. Identification service determines the identity of a user and authentication service verifies that identity. Authentication mechanisms fall into one of three types:

- **Authentication by Knowledge (Type 1)**—Something a person knows: passwords, codes, or PINs.
- **Authentication by Ownership (Type 2)**—Something a person owns or possesses: tokens, magnetic stripe cards, PCMCIA cards and smart cards.
- **Authentication by Characteristics (Type 3)**—Something that is a physical aspect of the person, including unique personal biometric characteristics such as fingerprint, retina, or facial.

The rest of this section will discuss Type 3, authentication by characteristics, also known as biometrics authentication. Biometric technologies include both the automatic collection and comparison of characteristics stored in an electronic medium and later used to confirm the identity of an individual. A typical authentication process consists of the following basic steps:

- **Enrollment or Capture Phase**—The actual biometric sample is taken from the user and stored in a database.
- **Feature Extraction Phase**—The appropriate measurements of the biometric sample are taken from the live scan of the user.
- **Comparison Phase**—The features extracted from the live scan are compared with the template stored in the database.
- **Decision/Evaluation Phase**—The processed data that has been compared is evaluated and given a score. Depending on the security threshold, access will either be granted or denied.

The methodology for integrating products into usable solutions requires directorates, customer requirements, a prioritization process, and viable solutions that culminate in a decision to accept, reject, or delete the request.

## 7.1.6 Cases

The potential for insider attacks alone makes it paramount for security mechanisms to be implemented for all applications and on all workstations. How strong these security mechanisms need to be depends on the damage a successful attack could cause. Cases can be defined based

on the sensitivity (security classification) of a workstation user, the associated threat, and the enclave configuration. High-sensitivity workstations are assumed to employ complementary confidentiality, integrity, and availability mechanisms, e.g., strong authentication and encrypting and signing files and e-mail. As sensitivity-classification differences between workstations and individuals in an enclave increase, the need for the countermeasures increases. As the size of the enclave increases, the need for coordinating and managing its security similarly increases.

### **7.1.6.1 Cases Within the Enclave**

The following cases represent different environments where security mechanisms are needed on workstation applications to protect information within the enclave boundary:

- Individual user with unclassified information that is personally sensitive within an unclassified enclave.
- Individual user with classified/restricted information within an enclave of equal sensitivity level.
- Subnet of users with unclassified information that is limited to these users within an unclassified enclave.
- Subnet of users with classified/restricted information within an enclave of equal sensitivity level.

### **7.1.6.2 Cases Transiting the Enclave Boundary**

Although cases involving information transiting enclave boundaries are handled elsewhere in this framework, applications can further protect this information. The following cases represent environments where the application can provide this additional layer of protection:

- Individual user with U/SBU personally sensitive information communicating with an unclassified network, e.g., the Internet.
- Individual user with classified/restricted information connecting to a network of equal sensitivity level.
- Remote user connecting through a public network to an unclassified local area network (LAN) (remote access).
- Remote classified user connecting through a lower level network to a classified network (several subcases by deltas in levels) (remote access).
- Unclassified/sensitive/restricted but lower-value-information LAN connecting to a large, open, unclassified network, e.g., the Internet (many adversaries of varying capabilities).
- Unclassified or classified (valuable information) LAN connecting to a network of the same classification (less open).

- Classified LAN or LAN containing valuable information communicating through a lower level network to another network of equal classification (System High Interconnects).
- Classified LAN or LAN containing highly valuable information communicating with a lower classification network (High-to-Low, multilevel security [MLS]) (multiple subcases exist for varying deltas between information on the LAN versus the wide area network [WAN]).
- Classified LAN or LAN containing valuable information connecting to same classification/value/organizational WAN that has limited connections to lower classification/value/external network, e.g., secret LAN connected to a secret WAN that is also also connected to an unclassified WAN.
- Sensitive, restricted, or compartmented information LAN or subnet connecting to a corporate net or intranet.

The first four cases describe a single workstation connecting to a similar-security-level component, employing a potentially lower sensitivity transmission medium. Cases 5 through 7 are interconnected networks of essentially the same sensitivity level, employing unprotected (lower sensitivity level) transmission media. Cases 8, 9, and perhaps 10 involve high-to-low connections that may jeopardize interconnected high-level systems that are not aware of the low connection. Case 10 may involve a range of differences in information value of the subnet versus the network.

## 7.1.7 Framework Guidance

This framework characterizes the security features and assurances needed to protect information in today's richly interconnected environments. Applications process and circulate information, providing affordable security-enabled applications is therefore paramount to providing information assurance for the system. If implementing security-enabled applications involves significant financial investment, organizations and users will be reluctant to implement them. Developers must strive to create security-enabled applications that meet user needs without adding extras that drive costs to prohibitively high levels.

This section will not provide guidance for each case presented in Section 7.1.6, but will offer provide guidance that can apply in all cases. Specific requirements for each case and application type will be provided in the form of protection profiles that support the DoD Defense-in-Depth strategy.

### 7.1.7.1 User Interface

A security mechanism that is cumbersome to use will not be used. The importance of an intuitive and burden-free user interface for day-to-day operations cannot be overemphasized. The user interface also affects key management, both procedural and electronic, at least during start-up and it is important that it does not cause undue burden. If it does, encryption and digital

signatures will not be widely accepted or used within the organization. The interface should keep the user apprised of security-related events and information, such as—

- Outgoing information that has been encrypted or digitally signed.
- Incoming information that is encrypted or digitally signed.
- The identity of the person who encrypted or digitally signed the incoming information.

### 7.1.7.2 Security Mechanisms

Not every vendor implements security mechanisms in the same way. Providing configurable options increases the chance that products from different vendors will operate together. These mechanism options can include the algorithms and associated key lengths supported by the application and the protocols used to transfer information between users, e.g., S/MIME or MSP for messaging. There must be a trade-off between the need for the secure application to support a number of options and the need for the application to be inexpensive and easy to use. Generic applications should be able to determine the mechanisms that are common when two or more applications attempt to interoperate.

There are two ways to add security mechanisms to applications: First, software plug-ins with security features can be added to existing nonsecure applications, or alternatively, security mechanisms can be directly integrated into the application during product development. Although there are advantages to both methods, the second is preferable. Security should be an integral part of an application, not an afterthought. The following is a list of constraints that security-enabled applications should meet:

- Applications with similar functions should interoperate, e.g., secure e-mail packages can communicate with different secure e-mail packages.
- The user has the choice to enable security mechanisms selectively for each message or file being sent.
- The user should be able to apply to information encryption only, digital signatures only, or both encryption and digital signatures.

The encryption and digital signature mechanisms (e.g., algorithms, key lengths, or random number generators) should be of sufficient strength and responsive to the current legal policies for the environment in which they will be used.

### 7.1.7.3 Certificate Revocation and Validation

A policy is needed for certificate revocation. The issues surrounding such a policy include what determines when a key should be revoked; who can request a revocation; what actions need to be taken once it is discovered that a received certificate has been compromised; where the list of revoked certificates is maintained; and how the list is disseminated. Electronic mechanisms must be in place to enforce the revocation policy. The security administrator should be able to configure the revocation enforcement mechanisms as needed to implement the site's policy.

Revocation is necessary when a certificate becomes invalid before its normal expiration date. Some reasons that a certificate becomes invalid are—

- User name change (e.g., marriage).
- User status change (e.g., termination of employment).
- Compromise or suspected compromise of the private key (e.g., loss of the token or fraudulent use).

If a private key becomes compromised, an information systems security officer or someone else responsible for the organization's computer security should be notified as soon as possible.

Revocation is the process of removing a certificate from operational status. The end user or responsible party can request revocation, as can any authorized personnel. The most common revocation method is through publication of a Certificate Revocation List (CRL). When a certificate number appears on a CRL, other users know that it is not to be relied on.

It is important for the CRL to be maintained in a location that is easily accessible to all users; the policy must establish the identity of the trusted central server and the circumstances under which the users must check with that server. For example, a CA is a component of a PKI that is responsible for maintaining and publishing CRLs. The CA prepares each new CRL using facilities on the CA server and posts the CRL on a directory server either in its complete form or incrementally. Incremental versions identify changes from the previous incremental release.

Another technique to check the validity of a certificate is dynamic-real time validation. A protocol that supports this is the on-line certificate status protocol (OCSP). For each validation, the relying party requests the status of the certificate from a revocation service, which maintains an unpublished list of revoked certificates.

As another measure to revoke a certificate, the certificate being revoked should be removed from the certificate repository.

#### **7.1.7.4 Password Practices**

A security policy must include good password usage practices for the site. FIPS Publication 112-1, "Passwords Usage," provides information on good password practices, among them minimum password length of ten alphanumeric characters, maximum period of password usage, and random words (nondictionary). Electronic mechanisms should be in place to enforce good password practices, particularly when the passwords protect private key information. The security administrator should be able to configure the password enforcement mechanisms so as to implement the password policy.



## 7.1.7.5 Technology Gaps

Though the tools, mechanisms, and services necessary for building secure applications are generally available, there are serious gaps. The gaps result mainly from the difference between known capabilities and needs and the solutions that are available. Finding a full vertical solution is quite difficult; it would include tokens, certificate infrastructure, and applications that all understand each other, use the same type of certificate with the same fields, and as needed, use the same standards for interoperability.

This ideal solution is nearly impossible to find today. The market is fragmented at virtually every horizontal level. Tool vendors use different algorithms, service vendors use different protocols, standards are not completely defined for interoperability, the certificate infrastructure uses different certificate extensions (sometimes with different meaning or intent), directory services and query modes vary, and the applications use different standards or different protocols. E-mail is an excellent example: the Defense Message Service uses MSP mail formats, the commercial world uses S/MIME and OpenPGP. Some applications use X.509 version3 certificates, others still use version1.

This gap in vertical solutions is expected to be filled as products from larger vendors (Sun, Microsoft, Lotus, and IBM) begin to appear, but in the meantime, vertical solutions are often proprietary and thus of limited interest to the Government. As the gap in basic solutions narrows, there will be more concern with the capability and security provided by the products, with some implementations simply being more robust than others. Security for new technologies (smart cards, PCMCIA cards, dynamic hypertext markup language [HTML], Virtual Reality Modeling Language [VRML], and others), though needed, may be lacking in the first generation of products. Testing, evaluation, and use will eventually disclose the real security gaps are in applications, and what can best be done about them.

## References

1. Honorable Emmett Paige, Jr. Selection of Migration Systems. Assistant Secretary of Defense Memorandum. November 1993.
2. Linn, J. Generic Security Service Application Program Interface. RFC 2743, Version 2, Update 1, January 2000.
3. Adams, C. Independent Data Unit Protection Generic Security Service Application Program Interface (IDUP GSS API). RFC 2479. December 1998..
4. X/Open X/Open Preliminary Specification: Generic Cryptographic Service API. draft 8, 20 April 1996.
5. RSA Laboratories. PKCS #11 v2.11: Cryptographic Token Interface Standard. November 2001.
6. National Security Telecommunications and Information Systems Security Committee, National Information Systems Security Glossary. NSTISSI No. 4009. 5 June 1992.
7. National Computer Security Center. An Introduction to Certification and Accreditation. NCSC-TG-029, January 1994.
8. National Computer Security Center. A Guide to Understanding Security Modeling in Trusted Systems, NCSC-TG-010. October 1992.
9. Microsoft Corporation. Application Programmer's Guide: Microsoft CryptoAPI. Version 2.0, August 2001.
10. NSA Cross-Organization Team. Security Service API: Cryptographic API Recommendation. National Security Agency. 1996.
11. Schneier, Bruce, *Applied Cryptography*, 2<sup>nd</sup> edition. John Wiley & Sons, 1996.

**UNCLASSIFIED**

Defend the Computing Environment  
IATF Release 3.1—September 2002

**This page intentionally left blank.**

## 7.2 Detect and Respond Capabilities Within Host-Based Computing Environments

Fundamental goals of the Defense-in-Depth strategy are—

- Prevent cyber attacks from penetrating networks and compromising the confidentiality, integrity, and availability of enclave information.
- Detect and respond effectively to mitigate the effects of attacks that do penetrate and compromise the network. The host computing environment is the final line of defense for the Defense-in-Depth strategy. The fact that these workstations and servers can be vulnerable to attacks through poor security postures, misconfiguration, software flaws, or end-user misuse must be factored into the protection approach.

While detect-and-respond technologies offer perimeter and access controls, authorized internal and remote users within an enclave can attempt probing, misuse, and malicious activities, particularly when they have been authenticated by a host computer either as an authorized user or by impersonating an authorized user.

Detect-and-respond capabilities are complex structures that run the gamut of intrusion and attack detection, characterization, and response. The detect aspects of detect-and-respond are actually measurement services. Intrusion detection, network scanning, host scanning, and the like are measurement functions that, continuously or periodically determine the effectiveness of the protection systems deployed. Detect capabilities do not protect, but the respond capabilities can change protection mechanisms (e.g., instituting automatic disabling of a user's account after too many failed login attempts) or deploy new protections (e.g., stronger authentication systems).

The local computing environment is the logical location for host-based sensors within an enclave. This section addresses host-based sensors, including those that operate in near real time and those that operate off-line. Specific host-based sensor technologies addressed in the framework are shown in Figure 7.2-1. Sections 6.4, Network Monitoring Within Enclave Boundaries and External Connections, and 6.5, Network Scanners Within Enclave Boundaries, provide similar guidance on network sensor

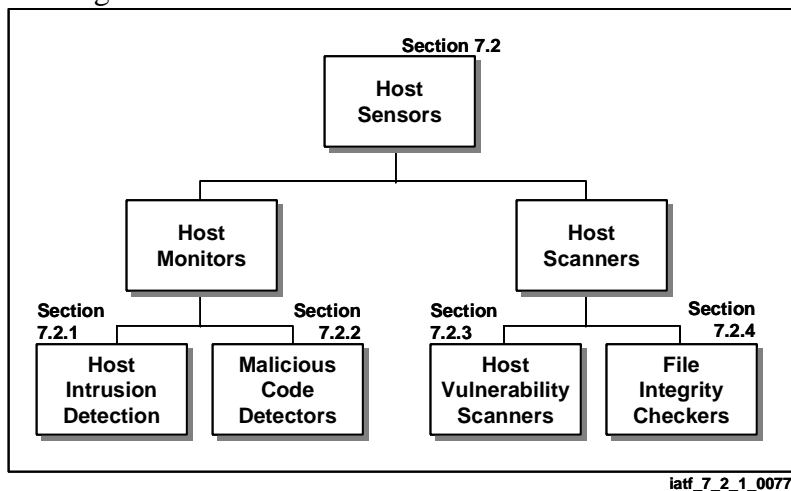

Figure 7.2-1. Breakdown of Host Sensor Technologies

technologies. There are common elements in the respective sections of the two chapters. Rather than cross-referencing the sections, each is structured as stand-alone for the convenience of the reader.

A number of functions (e.g., intrusion characterization and response formulation) are typically performed by analysts using the information provided by locally deployed sensors. Local environments may implement as much or as little above the sensors as they feel prudent, obtaining services and support from the system infrastructure as necessary. Section 8.2, *Detect and Respond as a Supporting Element*, discusses in-depth detect-and-respond processes in the context of information assurance (IA) infrastructure capability. It also offers guidance on technologies for processes beyond the sensors, though recognizing that they can be implemented at any level (including local) in an enterprise hierarchy.

Host-based sensors covered in this section include host monitors (intrusion detection and malicious code detector technologies) and host scanners (host vulnerability scanners and technologies for software integrity checking). The section reviews each relevant technology, general considerations for use, rationale for selecting features, and deployment considerations, and gives a perspective on how these technologies are typically bundled into products. The section concludes with sources of additional information and a list of references used in developing this guidance.

## 7.2.1 Host Monitors—Intrusion Detection

Today, most operating systems and applications generate an audit trail. Originally, it was intended that a security administrator would review the audit logs for suspicious events, but though this is current practice, the personnel typically available to review such logs are limited. Many enterprises do not use audit logs (or the tools to facilitate their analysis) for two major reasons. The tools themselves depend heavily on the user's ability to understand the types of attacks and vulnerabilities, and as the number of users, operating systems, applications, and databases grows, so do audit trail file sizes, which often consume too much storage space, possibly resulting in denial-of-service problems. Often, information technology (IT) operations staff are forced to delete or disable audit trails in order to avoid costly disruptions to their networks and information processing systems.

### Technology Overview

The goal of a host intrusion detection system (IDS) is to identify, in near real time, unauthorized use, misuse, and abuse of computer systems by internal network users. As discussed in Section 6.4, *Network Monitoring Within Enclave Boundaries and External Connections*, similar structures and technologies are also available for performing comparable functions using network-based information.

Host-based intrusion detection sensors collect information in the form of the audit trail reflecting on a particular system. Information includes system logs, other logs generated by operating system (OS) processes, and contents of system objects not reflected in the standard OS audit and

## UNCLASSIFIED

Detect and Respond Capabilities Within Host-Based Computing Environments  
IATF Release 3.1—September 2002

logging mechanisms. Systems can monitor information access in terms of who accessed what, map problem activities to a certain user identity (ID), and track behavior associated with misuse.

Host IDSs are based on the principle that an attack on a computer system will be noticeably different from normal system activity. An intruder, possibly masquerading as a legitimate user, is very likely to exhibit a pattern of behavior different from that of a legitimate user. The job of the IDS is to detect those abnormal patterns by analyzing the numerous sources of information provided by the system. Two major detection techniques are statistical analysis and rule-based expert system analysis.

- Statistical analysis attempts to define normal (expected) behavior. A popular way to monitor statistical measures is to keep profiles of legitimate user activities, such as login times, central processing unit (CPU) usage, favorite editor and compiler, disk usage, number of printed pages per session, session length, and error rate. The IDS uses the profiles to compare current and past user activity.
- Expert system analysis detects possible attacks on a computer system by searching for breaches of policy. It typically uses a rule-based system to analyze the audit trail records, trying to discover attacks based on the information contained in the rule base. The expert system can pose sophisticated queries to the rule base to answer conditional questions based on sets of events. These systems' main problem is determining exactly what the rules should be and what kinds of attacks can be detected by this method.

## Detection Approaches

Anomaly and misuse detection attempts to separate benign from intentional unauthorized use of a system, applying special technologies to detect changes in the patterns of use or behavior of the system.

- Anomaly detection techniques assume that all intrusive activities deviate from the norm. These tools typically establish a normal activity profile, a statistical model that contains metrics derived from system operation, and then maintain a current activity profile of a system. Observed metrics that have a significant statistical deviation from the model are flagged as intrusive. When the two profiles vary by statistically significant amounts, an intrusion attempt is assumed.
- Misuse detection systems attempt to identify misuse of computing resources by authorized users. They look for exploitation of known weak points in the system that can be described by a specific pattern or sequence of events or data (the "signature" of the intrusion). For example, the user may be visiting unauthorized Internet sites, navigating around a system to areas explicitly identified as off limits, or using an application for activity unrelated to work. Misuse detection typically relies on an administrator's using configuration files to define activity that is considered misuse. The information in the configuration files can then be compared with an activity on the system; misuse is assumed when there is a match.

## IDS Tuning Options

Typically, a host-based IDS provides capabilities for tuning its operation to a particular host and enterprise environment. Depending on the implementation, it is often possible to predetermine the types and specific attacks to be monitored, what the response will be for each detected intrusion (e.g., generate an alarm or record, or take a mitigating action), and characterize the class (e.g., the importance or severity) of each alarm generated. The IDS can be driven both by anticipated authorized activity on the host and the general information system usage characteristics across the enterprise. In this way, it is possible to focus the host IDS on specific events of interest, depending on what threats have been identified as relevant to the particular host environment and the response the IDS will have when events are detected. An IDS should not be deployed without a Concept of Operations (CONOPS) and a set of well-defined goals, host profile characteristics, and responses and tuning approaches.

Often, tuning requires evaluating IDS operation for a period of time at initial activation (some implementations do self-tuning) and then tuning out or desensitizing the monitor. Sometimes sensitivity may need to be increased, but most technologies come out of the box highly sensitive. Anomaly detection elements usually have a learning curve to determine normal patterns and distributions of activity. Finally, the adjustments can be made to deselect some activities and add others based on the analysis and correlation of alarms and alerts with other measures in the system.

## Response Options

Although the sensors collect information about intrusions, it is the analyst who interprets the results. Host-based IDS agents watch aspects of host or server security, such as OS log files, access log files, and application log files, as well as user-defined application policies. If a policy is breached, the host IDS can react by logging the action, alerting the administrator (notify a console, send e-mail, beep a pager), disabling an account, terminating an intruder's session, shutting the system down, or executing a command that in some cases stops the action before execution.

## Reporting Mechanisms

When the host IDS determines that the criteria have been met for declaring an intrusion, anomaly, or misuse event, it is generally configured to signal alerts to either a console interface or a centralized management station where information can be brought to the attention of an administrator. Some host IDSs can send e-mails, from the central console or individual agents, to alert an operator to events or initiate telephone pages if properly configured.

As with network IDs, many host-based IDs, central-reporting systems come with database components that allow the general manipulation or correlation of event data, as well as the generation of a wide variety of reports, both graphical and numerical.

## 7.2.1.1 General Considerations for Selecting the Technology

Rather than scanning network packets, a host-IDS watches the audit logs or other system resource events and activities on each monitored computer for signs of misuse. Host-based IDSs are easy to configure for individual servers and applications. They provide tailored security because they can monitor specific OS or application events and can enforce enterprise policies. Only host-based IDSs can detect an intrusion that occurs through the locally attached console, and when an attack is detected, only these IDSs can enforce a user-based reaction policy (e.g., disable the user account or terminate a user process).

A host IDS is well suited to monitoring specific user and file activity. However, because it cannot detect network-based threats, a host-based IDS should be considered a complement to network-based IDSs, supplementing detection of intrusions that may appear to be part of authorized traffic flows or that might otherwise be missed within switched environments. While use of both technologies is preferred, there are situations where it may be appropriate to use host-based IDS only—

- Network bandwidth is too high to enable network monitoring, or too low to justify the expense of a network IDS.
- The network environment is highly switched (logically segmented), without span ports on the switches, or the mesh is too large, making the number of sensors needed prohibitively expensive.
- The topology is too highly distributed (either geographically or logically segmented).
- Organizational/domain communities of interest or ownership issues (e.g., different organizations own the network and the hosts or a subset of the hosts, and these organizations do not communicate well).
- There are privacy or consent issues; it is much easier to have a “consent to monitor” policy when logging into a host than a network.

A classic case in which host-based IDSs are the only practical approach is a high-performance computing community where a loose coalition of high-end computing environments shares data, but the owners of the processing capacity do not own the network.

Host-based IDS performance varies according to the number of standard attack definitions and enterprise-specific policies being monitored, and the number and type (compute-bound versus input/output-bound) of processes executing on the host, as well as the speed of the host and its components. Another factor is the enterprise architecture for host management.

Although intrusion detection and response systems are important components of an enterprise security program, the devices currently in use have many flaws. Host-based IDSs rely on after-the-fact analysis of audit data to detect suspicious activity and anomalies and are difficult to



UNCLASSIFIED

scale for use in large enterprise environments. In addition, they may cause computational overhead on mission-critical servers and hosts whose security is being monitored, because the IDS resides on the same machine.

Another consideration is complexity of deployment and administration, which varies depending on how many and what types of servers are being protected. A host-based IDS cannot address attacks that exploit protocol vulnerabilities, and since IDSs analyze data from the audit trails, they typically do not react to an attempted intrusion in real time. Moreover, the access to audit trails is available only at the OS or the application level; that is why host-based IDSs should be implemented in the context of a total Defense-in-Depth security posture with a comprehensive approach to enclave boundary security.

Table 7.2-1 summarizes the advantages and disadvantages of host-based IDS technologies.

**Table 7.2-1. Host-Based IDS Considerations**

Advantages	Disadvantages
<p>Provides a real-time measure of the adequacy of a system’s access control and protection.</p> <p>Systems can monitor who accessed the system.</p> <p>Systems can map problem activities to a specific user ID.</p> <p>Systems can track behavioral changes associated with information system misuse, typical of an insider of the information system.</p> <p>Systems can operate in an encrypted environment.</p> <p>Systems can operate in a switched network environment.</p> <p>On large networks, systems can distribute the load associated with monitoring across available hosts.</p>	<p>Network activity is not visible to host-based sensors.</p> <p>False alarm rates are high with current technologies.</p> <p>Activating audit mechanisms can add to resource overhead on the system.</p> <p>Audit trails used as data resources can take up significant storage space.</p> <p>Operating system vulnerabilities can undermine the integrity of host-based sensors and analyzers.</p> <p>The management and deployment costs for host-based systems are greater than for other approaches to intrusion detection system.</p> <p>Host-based sensors are more platform-specific, which adds to their cost and the expertise required of operators.</p>

Finally, the degree to which the host-based IDS is configured to monitor a particular system should depend on the sensitivity of the information being processed or the criticality of the system to the integrity and availability of the entire enterprise.

Host-based IDS systems come with operational and managerial burdens. These include alerts that require specific administrator examination, implementations that may be available only for specific OSs, and system performance that affects the host. Without careful planning, a broad deployment of host-based IDSs is not recommended. A threat and risk assessment is strongly recommended to identify particular hosts on which to add IDSs, followed by a careful deployment and continual monitoring for performance impact or operational degradation.

## 7.2.1.1 Important Features

In selecting host-based IDS, a number of features should be considered. This section identifies those features, and the next section discusses the rationale for choosing the features.

### Detection

- Support for detection of service start-up.
- Ability to detect registry changes.
- Ability to watch files and objects.
- Ability to profile normal activities and detect variations from the norm.

### Signatures

- The number of events and signatures that can be detected.
- Checking for file or message integrity that is based on cryptographic algorithms, not simple checksums.
- Customizable system checks.

### Operations

- Deployment and management capabilities of the complete IDS system (e.g., number of agents that can be connected to a single manager and number of managers that can report to a single console).
- Ability of the auditing process to automatically reset itself.
- Support for remote management.
- Ability to integrate with network-based modules; how well the tool works in a heterogeneous environment becomes a critical factor for enterprise-class IDS tools.
- Survivability characteristics (self-recovery from power loss, resource failure, component failure, and similar situations).

### Response Options

- Configurable, automated, rule-based response capabilities.
- Account blocking, access control changes.
- Ability to coordinate responses across multiple host platforms (e.g., disable the same account on all enterprise systems).
- Integrated response with network-based tools.

## UNCLASSIFIED

Detect and Respond Capabilities Within Host-Based Computing Environments  
IATF Release 3.1—September 2002

### Reporting Options

- Ability to perform Simple Network Management Protocol (SNMP or trap) alerting to centralized system management.
- Ability to use e-mail alerts and a variety of other contact measures (pager, fax, etc.) to notify personnel.
- Ability to execute programmed scripts automatically on alerts at management system or console (also partially a response function).
- Ability to generate customized reports as needed.
- Ability to capture events in a standardized database system.

### Performance

- Balance between the overhead required to audit OS and application activity logs and the ability to react to infractions.
- Effect of data log on system resources (since host-based IDS generates log files as well).

### Platform

- The specific types of platforms (e.g., OS) on which the tool operates.
- Minimum platform configuration.
- Memory requirements.
- Disk resource requirements.
- Ability to handle crossover when reporting between platforms.

### Console Considerations

- **Operator Interface**—Command and monitoring provisions available to an operator.
- **Mark as Analyzed**—Ability to clear or mark alarms that have been reviewed.
- **Drill Down**—Ability to provide additional information for selected events.
- **Correlation**—Tools to correlate events based on source, destination, and type.
- **Report Generation**—Ability to generate reports upon event detection and as periodic summaries.
- **Integrated Industry**—Standard database.

### 7.2.1.3 Rationale for Selecting Features

In choosing detect-and-respond capabilities, operations and personnel considerations must be integrated into the technology solutions, consistent with the overall Defense-in-Depth philosophy. Because host-based monitoring does not itself offer protection from intrusions or attacks, it should be considered more as instrumentation that monitors and measures the effectiveness of the host computer's existing protection structures. It is up to system administrators (support and operations staff) to interpret IDS outputs and reports and initiate the response. If full-time operators<sup>1</sup> are not available to interpret IDS outputs and formulate responses, IDS implementations will typically not add real value and IDS deployments should probably not be considered.

If an IDS is being considered, a number of factors must be taken into account based on how the IDS is intended to be used, whether full- or part-time operators will be available, and how skilled the operators are in interpreting the results.

#### Detection

Most host-based IDS technologies actually use a mix of both signature matching and anomaly or misuse detection. Both have advantages. Although signature-based IDSs are traditional, they typically cannot detect new or modified attack patterns. While many intrusions, particularly by novices, use standard attack sequences (often downloaded from hacker bulletin boards), an accomplished adversary will be able to create new attacks or modify old attacks and thus thwart traditional signature detection mechanisms.

Anomaly and misuse detection approaches (e.g., statistical profiling and unauthorized system resource use or modification monitoring) have greater flexibility for identifying new or modified attacks because they monitor network usage or behavior. These are also the only mechanisms currently available to monitor actions of otherwise authorized users for misuse, whether inadvertent or intentional. They can sometimes be more complex to operate and manage, but in most technologies, the degree to which each aspect (signature versus misuse/anomaly) is enabled and configurable.

As always, any decision is based on level of risk, anticipated performance, cost (for purchase, deployment, and operation), and operational impact. This framework recommends deployment of multiple attack detection schemes, where possible, to increase the likelihood of detection.

---

<sup>1</sup> Ideally operators should be available round the clock every day. The number of operators needed will depend on the traffic loads and the likely numbers of incidents. Hundreds of thousands of intrusion alerts per day are not uncommon, and each has to be investigated to determine whether the threat is serious.

## Signatures

In a signature-based IDS or IDS component, it is desirable to have as many signatures as possible available. However, increasing the size of the signature set will decrease the overall performance of most IDSs. Since the lists of possible attacks change often, it is strongly recommended that the IDS be capable of dynamically loading signatures. It is usually operationally more feasible and efficient if the downloading is handled on an enterprise (or at least site) basis. Most vendors that offer dynamic loading of signatures provide periodic updates to the signature base; a good rule of thumb is that having more frequent updates is better. If operators have the skills to create custom signatures, the ability to support user-defined attacks is also desirable, particularly if custom attacks are found at a site.

## Operations

Easy configuration of the IDS according to the security policies of the information system being monitored is desirable. The IDS should also be able to adapt to changes in system and user behavior over time (e.g., new applications, users changing from one activity to another, or new resources that cause changes in system resource usage patterns).

By their nature, IDS sensors are located where intrusions are likely. IDS sensors are also high value targets in themselves. To this end, if such modifications occur, an IDS component within a host system should be self-monitoring, detecting unauthorized modifications and notifying an attendant console. To simplify return of full operations after an intrusion, it is also desirable that the IDS be able to recover from system crashes, either accidental or caused by malicious activity, and be able to recover its previous state upon start-up.

## Response Options

Many solutions offer automated response options that seem on the surface to be very desirable. They imply the need for little or no human interaction, as the devices can provide an immediate response. Unfortunately, though, it is not uncommon for a host IDS, depending on where it is employed, to identify as potential misuse many events that are in fact characteristic of normal host usage. Without careful tuning, the number of false positives may be high, giving rise to unwarranted indications of intrusions. Automated responses that terminate user sessions, modify access controls, throttle processes, or actually shut down a system can often cause severe denial-of-service threats to the network. It is strongly recommended that automated options not be used unless there is some mechanism to control the potential for denial of service.

## Reporting Options

Most host-based IDSs report alarms to an operator console (see the discussion of console features below). Which level and frequency of reporting are desirable depends primarily on the skills of the operators available. Some host IDS technologies offer the option of paging or sending e-mail messages to notify personnel of alarms. While these sound desirable, they may give rise to operational issues: With an IDS detecting thousands of alarms a day, these features

might overload e-mail servers, creating a denial-of-service threat themselves, or page operators far too often at all times of the day and night. These features are generally not recommended, at least not until a baseline of normal behavior is identified.

## Performance

Host IDS performance varies based on the available resources (processor, bus architecture, disk space) of the host system, the operational applications it is executing, the number and type of processes it experiences during operations, the number of attack signatures employed, and the level and complexity of audit or analysis the IDS is configured to undertake. Unlike network-based intrusion detection sensors, where performance degradation results in the loss of intrusion detection capabilities but not network performance, host-based sensor software can affect the entire host system itself. In each case, a trade-off must be determined between the levels of audit the sensor software is configured to undertake and the effect on overall system performance. Where existing host performance is already marginal, redesign of the system and sensor software deployment approaches should be considered—host-based IDSs must be deployed very carefully.

## Platform

A major issue in selecting host-based IDS is the type of computer skills (e.g., UNIX, NT) required of operators. They are likely to need the skills necessary to install, configure, adjust, and maintain the system. Since a host-based IDS is usually deployed in an existing system, knowing what is already running on the system and the resources it requires is critical. In addition, the console platform must be acquired and maintained, so it is useful to select a technology that functions on the platforms used within the enterprise.

## Console Considerations

As discussed in Section 8.2, Detect and Respond as a Supporting Element, the primary function of the console is to help characterize and analyze the many alarms that will be identified. Operators must identify alarms that resulted from authorized use (e.g., false alarms), those that do not offer serious risks to the network, and those that do; they must also gain an initial perspective on the source and impact of possible attacks.

**Operator Interface**—The type of interface that is operationally desirable tends to depend on operator preference. Novices typically prefer a graphical user interface (GUI) with intuitive operations, pull-down screens, and substantial aids. More skilled operators may prefer command string operations, tailored screen options, and more customization options. It is best if operators can get a hands-on trial of console capabilities before final selection.

**Mark as Analyzed**—Because operators will typically be faced with large numbers of alarms to be analyzed and cleared, the ability to keep track of alarms that have been reviewed is usually critical.

## UNCLASSIFIED

Detect and Respond Capabilities Within Host-Based Computing Environments  
IATF Release 3.1—September 2002

**Drill Down**—Many host IDS consoles display a high-level characterization of events in order to display the large number of alarms that are detected. Operators must usually access additional details about each alarm to characterize it properly. It is very desirable that the console be able to provide these additional levels of information upon request. As with the operator interface, the types of information desired depend on the skills of the operators.

**Correlation**—As with drill-down features, operators need tools for correlating incidents (e.g., based on source, destination, type of alarm or event) to identify and properly characterize intrusions and attacks, particularly when the incidents are distributed in time or location. Console ability to integrate the reporting of host-based and network-based IDSs and other relevant events is a strong plus—if the operators will use the additional information. Again, as with the operator interface, the types of tools that will be useful typically depend on the skills and mission of the operators.

**Reporting**—The reporting options will depend predominantly on the type of information operators want for characterizing intrusions and the organization's need for reporting to higher levels (e.g., periodic summary reports). It is always desirable for the console to be able to generate reports that can be disseminated with little extra operator effort.

## Considerations for Deployment

A host-based IDS is designed to monitor a single host on which it (or its agent) resides. Typically, it can watch data available from higher levels of protocol stacks, which restricts its ability to monitor activities to audit trails made by the OS or applications. It also can detect the activities that occur locally on the monitored host (e.g., file permission modification and user account setup).

Host-based IDSs fall into two basic configurations: single system and agent/manager. A single system IDS protects one machine by detecting intrusions in the machine's audit logs and through other methodologies. A manager/agent host-based IDS places agents on one, some, or all hosts; IDS agents reside on the systems that are to be monitored. These host-based systems rely on analysis of OS event logs and audit processes (among other techniques described above) to detect suspicious activity. They are part of a distributed architecture in which the system agents report to a centralized management station, with agents connected to managers that are connected to a central console. Agents can remotely upgrade or install new versions and attack-signature rules. This configuration allows security administrators to define and distribute rules from one central location.

Some host monitors can also track audit trails from other applications, like firewalls, Web servers, and routers. These fall into the category of network-based monitoring capabilities, which are discussed in Section 6.4, Network Monitoring Within Enclave Boundaries and External Connections. While the Information Assurance Technical Framework (IATF) focuses on the technology aspects of an overall IA solution, the value of an IDS is realized only when a competent operator or analyst can interpret the result. Operators must be trained to ensure that they have the analytical skills and proficiency with tools to make correct interpretations

efficiently. They also need procedures (e.g., courses of action, standard operating procedures) for all contingencies, particularly for when serious attacks are discovered.

### 7.2.1.4 Considerations for Operation

Most IDS technologies can tune the sensor to improve its performance for specific deployments. When an IDS is first deployed, it is prudent to complete tuning by operating the technology for some time (depending on the complexity of the deployment). This provides an opportunity for determining that the IDS can monitor applications and detect alarms and for increasing or decreasing sensitivities. Also, anomaly detection elements usually have a learning curve for establishing a baseline for normal patterns and distributions of activity. The tuning period also allows for other adjustments to deselect some activities and add others based on an analysis of the alarms triggered.

Tuning enables the IDS to preclude detection of authorized traffic patterns that may otherwise cause false-positive alarms. There are two fundamental approaches to tuning. The first is to have prior knowledge of the usage patterns that could trigger false alarms. The IDS can then be configured (tuned) to preclude these from causing an alarm. Unfortunately, it is often not possible to have this information in advance. The other approach is to run the IDS and to have it find conditions that generate alarms. As alarms are detected, an analyst determines whether there was an actual intrusion, or whether the alarm was the result of a false positive based on normal operation. The IDS can then be tuned to preclude those events from triggering an alarm. This method also gives operators an opportunity to become familiar with the technology before it becomes operational.

Tuning should not be thought of as strictly an installation process. It should be performed regularly to refine and focus the detection mechanisms on real intrusions and reduce false positives.

Once an IDS is deployed, it is recommended that the IDS be tested to ensure that it is configured correctly and is functioning properly. While it is also possible to construct exercises to test the proficiency of the operators and analysts, normal day-to-day operations are likely to provide more than enough real alarms to provide opportunities to assess their capabilities.

## 7.2.2 Host Monitors—Malicious Code or Virus Detectors

Over the past decade, computer viruses<sup>2</sup> have gone from an academic curiosity to a persistent, worldwide problem. Viruses can be written for, and spread on, virtually any computing

---

<sup>2</sup> The term “virus” is often misused as referring to *anything* that “infects” a computer *and* causes damage. A more appropriate term for any software that attacks a system is “malicious code.” Nevertheless, in the following paragraphs, the term *virus* encompasses all malicious code and delivery mechanisms.



platform. When first introduced, they were often structured as boot sector attacks, typically promulgated by first infecting the floppy disks that are read during start-up. Because the primary file transfer mechanisms today are electronic means such as e-mail, boot sector viruses are no longer a major concern. Typically, viruses today are written to affect personal computers (PC); if the PC is connected to other machines on a local area network (LAN), it is possible for the virus to invade these machines as well. Section 6.6, Malicious Code Protection, contains detailed descriptions of various types of malicious code, potential malicious code attacks and countermeasures, and requirements for detecting malicious code.

### 7.2.2.1 Technology Overview

Malicious code scanning technologies prevent or remove most types of malicious code. Using these technologies with current virus definitions is crucial in preventing and detecting all types of malicious code attacks.

There are several basic categories of antivirus technologies:

- **Preinfection Prevention Products**—A first line of defense against malicious code, used before a system has been attacked.
- **Infection Prevention Products**—Used to stop replication processes and prevent malicious code from infecting the system.
- **Short-Term Infection Detection Products**—Used to detect an infection very soon after it has occurred.
- **Long-Term Infection Detection Products**—Used to identify specific malicious code on a system that has been infected for some time, usually removing the malicious code and returning the system to its prior functionality.

Section 6.6.5.2, Viruses and E-Mail, contains a more detailed description of malicious code detection technologies.

### 7.2.2.2 General Considerations for Selecting the Technology

Workstations with individual access to networks or information service should have malicious code protection, as should networks at the gateway (see Section 6.4.2, Malicious Code or Virus Detectors). Malicious code can destroy data through network connections if allowed past the gateway or through individual user workstations. Although a single user can bring an infected disk to work, infecting his or her workstation and eventually the entire network, most malicious code infections result from file sharing. Because so many individual users now keep all data files on networks or shared file systems instead of diskettes, continuous protection of network connections at the gateway is important.

### 7.2.2.3 Important Features

In selecting antivirus technologies, a number of features that should be considered. These technologies are identified in this section, and the rationale for selecting them is discussed in the next section. Additional factors to consider when selecting a malicious code detection product can be found in Section 6.6.6, Selection Criteria.

#### Detection Capabilities

- Data integrity checks.
- Ability to exploit malicious mobile code.
- Real-time virus scanning.
- On-demand virus scanning.
- Recognition of—
  - Different strains of polymorphic viruses.
  - Viruses residing in encrypted messages and compressed files.
  - Viruses in different languages (e.g., JAVA, ActiveX, Visual Basic).
  - Trojan horses and worms.

#### Updates

- Ability to upgrade an existing version.
- Availability of regular updates.
- Frequency of update releases.

#### Response Mechanisms

- Quarantine at the server level.
- Quarantine at the console level.
- Network-based responders.
- Alerts sent to network or system administrators.
- Alerts (in the case of e-mail-borne viruses) sent to sender and all receivers.

#### Platform Considerations

- What platforms the tool runs on.
- Availability of cross-platform support.

### 7.2.2.4 Rationale for Selecting Features

When selecting antivirus technologies, two important guidelines should be followed. The “best” technology may not be good enough by itself. Also, since data security technologies operate in different ways, one technology may be more useful than another in different situations. Keeping

## UNCLASSIFIED

Detect and Respond Capabilities Within Host-Based Computing Environments  
IATF Release 3.1—September 2002

these guidelines in mind and rating each of the following categories will allow an organization to choose the best malicious code protection technology for its unique needs.

### Detection Capabilities

Most computer-virus scanners use pattern-matching algorithms that can scan for many different signatures at the same time (see Section 6.6.5.2, Viruses and E-Mail). Malicious code detection technologies must be able to detect known and unknown worms and Trojan horses. Most antivirus technologies search hard disks for viruses, detect and remove any that are found, and have an auto-update feature that enables the program to download profiles of new viruses so that it can scan for them. The virus signatures these programs recognize are quite short—typically 16 to 30 bytes out of the several thousand that make up a complete virus—it is more efficient to recognize a small fragment than to verify the presence of an entire virus, and a single signature may be common to many different viruses.

Although antivirus applications are essential for the detection of known viruses, no mail filter or malicious code scanner can defend against a new mail worm attack. Although the recent Love Bug virus was caught quickly, it still did a wealth of damage, and it is only a matter of time before crackers figure out how to send e-mail worms that infect systems without attachments having to be opened.

### Updates

Defending against virus and hostile-code threats takes far more than the ability to produce perfect detection rates at a single point in time. With an average of nearly 300 new viruses discovered each month, the actual detection rate of antivirus software can decline rapidly if the program is not kept current. As new viruses are discovered, so are corresponding cures to update protections. Antivirus systems should perform these updates automatically, reliably, and through a centrally controlled management framework. This is why an enterprise-class antivirus solution must be able to offer timely and efficient upgrades and updates across all client and server platforms.

### Response Mechanisms

Once malicious code has been detected, it must be removed. One technique is simply to erase the infected program, but this is a harsh method of elimination. Most antivirus programs attempt to repair infected files rather than destroy them. A virus-specific scanning program that detects an infected file can usually follow a detailed prescription, supplied by its programmers, for deleting the virus code and reassembling a working copy of the original.

There are generic techniques that also work well for both known and unknown viruses. One method is to gather a mathematical fingerprint for each program on the system so that if a program is later infected, a copy of the original can be reconstituted. Most tools scan for viruses, but not all detect and remove Trojan horses, worms, and malicious mobile code at all levels of entry. Most current antivirus tools do not have the same capabilities when responding across a

network. (Additional countermeasures related to malicious code can be found in Section 6.6.4, Potential Countermeasures.)

The technology should be easy to use, with clear and uncluttered menu systems and meaningful screen messages. Help systems are essential, as users need current information on all types of malicious code. The trend is to provide online help; however, the technology should come with manuals. The malicious code protection technology should be compatible with all other software and hardware, and create no conflicts. The company that produces the technology should be stable and able to provide local technical support for all questions and problems. The technology should be fully documented. All messages and error codes should be deciphered, and full installation guides and how-to manuals should be provided.

## **Platform Considerations**

The computers to run this software must meet the hardware and software requirements specified by the manufacturer. Malicious code protection software should perform its duties without failing itself or interfering with other applications running on the same system.

### **7.2.2.5 Considerations for Deployment**

Defense in Depth dictates that any virus protection must be implemented across the enterprise, on every system. Although some advocate only installing antivirus protection only on edge devices, such as servers, firewalls, and gateways, defense against viruses is only as good as its weakest link. If one system can be compromised, the entire enterprise is at risk.

Centralized antivirus management that imposes common policies is strongly recommended. Though some vendor offerings make end users responsible for security mandates, this can lead to more and more varied security holes. What often happens is that users have a session interrupted with a pop-up screen says their files are about to be scanned or they are about to receive an antivirus update. Many users then override the update manually, because it is distracting.

### **7.2.2.6 Considerations for Operation**

Most antivirus technologies send responses or alerts at the server level, and some at the console level. It is always desirable to notify anyone whose files may have been infected that malicious code has been detected, especially system and network administrators. When malicious code is encountered in e-mail transactions, it is desirable to notify both sender and recipient. If it is found on a file system that knows the file owner, that person should be notified. In general, anyone who could be notified should be.

## **7.2.3 Host Vulnerability Scanners**

In addition to the on-line host monitoring technologies that provide a critical layer of defense within enclave boundaries, another class of technologies—host scanners—can also be deployed

to improve overall security. The distinction between these scanners and network monitoring devices is that monitors typically operate in near real time and tend to measure the effectiveness of the host's protection services. This is more an "after the fact" measure than a preventive measure. Scanners, on the other hand, are preventive measures. Typically, they operate periodically (or on demand), examining hosts for vulnerabilities that an adversary could exploit. They measure security effectiveness.

Scanning can be performed at two levels. A remote (or network) scanner is run over a network against the target node, probing it for vulnerabilities. Here the software is running on an administrative system and scanning a target anywhere on the network (see Section 6.5, Network Scanners Within Enclave Boundaries). A local (or host) scanner runs as a software program that resides on the node itself. Host scanners are discussed here.

Unlike near-real-time host monitoring technologies, host scanners are typically executed periodically or on demand, providing perspectives on the posture of a local environment. Section 8.2, Detect and Respond as a Supporting Element, provides a perspective on an overall detect and response infrastructure, but because these assessments typically look at the local level, they tend not to interact with or be particularly relevant to a broader system infrastructure.

### 7.2.3.1 Technology Overview

Host-based vulnerability scanner tools examine the security posture of a host system from within, unlike network-based tools, which scan from the viewpoint of the network. Host scanners examine the contents of files looking for configuration problems, comparing what they find with predefined policies or best practices, and generating alerts when they detect possible security deficiencies. These technologies catch security problems that are not visible at the network level and that could be exploited by users with malicious intent who already have access to the system through valid means (or otherwise, such as stolen authentication information).

#### Detection

Scanners compare data about the host's configurations with a database of known vulnerabilities. They work either by examining attributes of objects (e.g., owners and permissions for files) or by emulating an attacker. In the latter approach, they run a variety of scripts to exploit any vulnerabilities in the host. Most scanners can be configured to select which vulnerabilities to scan for and when. Some scanners allow operators to incorporate their own scanning routines to look for site-specific application weaknesses. Some also offer capabilities for grouping hosts and customized options by scan group.

#### Scan Configuration Mechanisms

Each host in an enclave should be equipped with a host-based scanner. If the number of nodes is small, locally configuring the scanner and reviewing the results may be preferred in order to minimize network traffic overhead. If the network is large, it is often desirable to configure one or more consoles to control distributed node scanners. Some technologies have software

distribution frameworks for propagating this control. Hosts can be collected into groups, and a host can be a member of more than one group. Groups can be scanned at different times, with variations in the vulnerabilities inspected tailored to each group, enabling the operator to scan some hosts “deeper” than others. For example, one can configure the scanners to search for user configuration errors on hosts that serve many users and omit those scans on hosts (e.g., servers) that have no users.

## Response

When a host is scanned, some technologies create a “fix script” recommending corrective actions. It may be possible to customize this script or to run it to eliminate the vulnerabilities identified. Some also provide an unfix script that lets operators undo the fix script.

### 7.2.3.2 General Considerations for Selecting the Technology

One advantage of periodic scanning is that resource utilization is less on average than that required for real-time monitoring, because processing resources are required only when the scanner is active. Unlike host monitoring technologies that are intended to catch adversaries in the act, scanners reveal weaknesses that could be exploited later. Since host scanners actually run on the target node, they can look for problems that cannot be detected by remote (network) scans. They can also inspect patches to ensure that the latest security fixes have been installed. The obverse is that because scanners are run only periodically, they do not detect malicious events as they occur.

### 7.2.3.3 Important Features

In selecting host-based vulnerability scanners, a number of features should be considered. This section identifies these features; the next section discusses the rationale for choosing them.

#### Scanning Capabilities

- Ability to add custom scanning routines to look for site- or technology-specific weaknesses.

#### Signature/Vulnerability Database

- Comprehensive list made of vulnerabilities in the target host.
- Periodic updates from the vendor.
- Ease of adding entries by the user.
- Database backed by a vendor-funded research center, rather than just culled from Internet-based sources of vulnerability information or some combination of the two.

## Response Mechanisms

- Vulnerable ports of entry automatically shut off.

## User Interfaces

- Reports viewable in real time.

## Reporting Capabilities

- Automatic alerting when new nonnetwork ports are detected.
- All system answers logged in a database or file.
- Updated database of network numbers with which to compare newly identified numbers.
- Automatic combination of information logged into database, organized in a report format.
- Ability to suggest mitigation approaches for vulnerabilities discovered.

## Platform Compatibility

- Platforms (OS) on which the tool will run.
- Use of executables.
- Support for scripts or macros.

## Source

- For tools developed by the Government (or under Government sponsorship) information on whether tool is reserved and whether your organization can get authorization for its use.
- Reputation of the vendor.
- Availability of source code for tools in the public domain (e.g., freeware from the Internet).

### 7.2.3.4 Rationale for Selecting Features

The type and level of detail of information tools provide varies greatly. Although some can identify only a minimal set of vulnerabilities, others perform much more analysis and provide detailed recommended mitigation approaches. Select scanner technologies that cover the gamut of vulnerabilities for the given OS (e.g., UNIX or Windows), including password vulnerabilities, access control, resource and file permission signatures, registry problems, and the like. Select also technologies that offer a comprehensive library of vulnerabilities periodically updated by the

vendor. For larger environments, capabilities like grouping of nodes into scan groups and customized scan options may be valuable.

Some scanner technologies offer features whose usefulness depends on the training and skills of their operators. Depending on planned usage and operator skills, it is often desirable to select technologies that can be tuned to ignore some false positives. It is also desirable to select features that enable the scanner to be tuned for specific application environments, such as databases, Web servers, file servers, and firewalls, because such profiles may differ for the function the system must provide to the enterprise.

## **Signature/Vulnerability Database**

A significant characteristic of host-based vulnerabilities is that they tend to be unique to an OS, and even an application. Some applications that are portable also port their vulnerabilities across platforms, and can have different vulnerabilities on different platforms. And, obviously, operating structures differ drastically between the general UNIX base (and its variants), Windows 95/98, and Windows NT/2000. It is therefore important that the vulnerability database provided for the host-based IDS be comprehensive, adaptable, and well maintained by the vendor. IATF strongly recommends selecting technologies from vendors that do their own research and have specific expertise in OS vulnerabilities, rather than those that simply incorporate vulnerability signatures culled from other Internet-based resources.

## **Response Mechanisms**

Assessment tools will continue to evolve, with some vendors offering click-and-fix solutions. Assessment software flags vulnerabilities in terms of the risk posed to the network and the ease of the fix. Some technologies can generate trouble tickets to trigger a manual response. They may make it possible to change policies in firewalls and other enclave boundary defense mechanisms. Some identify patches that should be installed. Some offer to obtain and install patches. Although installing patches is feasible, security administrators can do it; in fact, the difficulty of undoing configuration changes makes this feature less desirable. Consider such features in light of the environment's current configuration management policies and procedures.

## **User Interfaces**

Typically, scanners are already configured with lists of vulnerabilities and can operate without customization. Some technologies allow operators to customize the vulnerabilities the scanner will investigate, and when. Newer tools provide user-friendly front ends and sophisticated reporting.

## **Reporting Capabilities**

Usually scan results are sorted into a file that can be accessed on demand. Old technologies inundated customers with phonebook-sized reports on all the vulnerabilities that the network faced. New technologies have database interfaces that prioritize vulnerabilities, allowing



## UNCLASSIFIED

Detect and Respond Capabilities Within Host-Based Computing Environments  
IATF Release 3.1—September 2002

network managers to deal with problems logically. Many generate reports that are Web-enabled, with hot-links and other “labor savers.” For sites with only a few platforms, running the scans and reading the reports on each node may be appropriate. For sites with large numbers of hosts, it might be wise to consolidate reports at a central server. If this feature is selected, it is recommended that technologies chosen offer encryption for information transferred from the local hosts to the centralized server to protect the scan results information.

### **Platform Compatibility**

The computers to run this software must meet the hardware and software requirements specified by the manufacturer. Vulnerability scanner software should perform its duties properly without inadvertently causing any of the monitored systems to fail or bringing anything else down. Technologies chosen should therefore have minimal effect on the performance of the host, and provide for cooperative computing resources for other services and applications on the host.

### **Source**

Host vulnerability scanner technologies are available from a variety of sources. Various Government organizations have created their own tools, usually for use by specific communities. The quality of these tools varies according to the skills and the testing of the developing organization. Use of any of these is likely to require authorization.

Other tools are available commercially or can be downloaded over the Internet. Unless Government tools have been found to be effective, commercial tools available from reputable vendors are recommended. Download from the Internet only if the source code is available so that the tool can be evaluated by an experienced analyst. If source code is not available, the tool may not detect actual vulnerabilities and worse, might actually introduce vulnerabilities (e.g., as a source of a malicious code attack).

### **7.2.3.5 Considerations for Deployment**

It is often useful to deploy vulnerability scanners in conjunction with a host-based IDS. An IDS will be able to identify when a file has been modified; however, it cannot determine what changes were made to that file. If there is a scanner, the IDS can invoke it to inspect the contents of the file. Maintaining configurations of owners, groups, and permissions for files and directories is one typically challenging task; scanners can ensure that these aspects of a security policy are properly implemented.

### **7.2.3.6 Considerations for Operation**

It is important to specify when, as well as what, scans are performed. Otherwise, mission-critical servers might become busy responding to simulated attacks during times of peak demand.

Assessment frequency is a function of how often network changes are made as well as enterprise security policy. Depending on the organization, assessments may take place quarterly, monthly,

weekly, or even daily. Some service providers offer subscription scanning services, ensuring that assessments take place regularly.

It is recommended that features that provide automated vulnerability repair be disabled. If they are not, the system must be backed up fully (including all system and application software) before any automated repair.

## 7.2.4 File Integrity Checkers

File integrity checkers are a specialized type of host scanner that verify the integrity of the files, detecting when files have been changed. As with the host vulnerability scanner technologies already discussed, these technologies tend to run off-line and thus are not a protection mechanism. Typically they operate periodically, based on an event (e.g., file access), or on demand.

### 7.2.4.1 Technology Overview

This is a small, tailored class of technologies, configured with the location of specific key configuration files or executables (depending on the OS in question) that are typically targeted by attackers attempting to compromise the system. These might include the registry environment, file permissions, security policy, and account information. The software typically generates cryptographic checksums of the targets and periodically probes to see whether the files have been surreptitiously modified. The best known of these technologies is Tripwire, but there have been some more recent entries into the field. A few host-based IDS monitors and vulnerability scanners have limited file integrity checking capabilities, and a number of technologies that started out as integrity checkers are evolving into policy violations checkers and vulnerability scanners. In fact, the two product lines are coalescing.

Most integrity checkers use the same general paradigm. They operate on files identified from a library of known files to monitor. Depending on the platform and OS, the technology creates unique identifiers typically based on cryptographic checksums, then stores them for future use. When the file integrity program is executed, either automatically or manually, new unique identifiers are calculated. The integrity checker compares the new identifiers with the saved versions and notifies the operator or administrator when a mismatch shows that the file has been modified or deleted. The operator or administrator determines whether the differences result from intrusive activity.

### 7.2.4.2 General Considerations for Selecting the Technology

General considerations for use of file integrity checkers closely parallel those of host IDS and vulnerability scanning in general, with a few additional discriminators. Most important is that file integrity checkers are supported by cryptography, providing stronger protection against their defeat by intruders. File integrity checkers that are configured to run in near real time provide

instantaneous indication of attack or failure, and if they are configured to run on files or data structures that do not change, their alarms require little or no interpretation.

Unfortunately, file checkers suffer from the same performance and resource consumption drawbacks as other host-based technologies. It is also critical to ensure that the baseline signatures from which the checkers function are both well protected from modification and, if they are dynamic configuration data structures, are created before the system is accessible to users. Table 7.2-2 summarizes the advantages and disadvantages of file integrity checkers.

**Table 7.2-2. File Integrity Checker Considerations**

Advantages	Disadvantages
<p>Checkers use cryptographic methods to provide additional security protections.</p> <p>Checker gives clear immediate evidence of intrusion when files that should never be modified are discovered modified, unlike host-based IDS reports, which must be interpreted, and alarms, which must be intercepted.</p> <p>System can operate within an encrypted environment because the host has access to decrypted versions of files.</p> <p>On large networks systems can distribute the load associated with monitoring across available hosts.</p>	<p>Network activity is not visible to host-based sensors.</p> <p>Checker may cause additional resource overhead on the system, depending on frequency of execution.</p> <p>OS vulnerabilities can undermine the integrity of host-based sensors and analyzers.</p> <p>File identifiers or signatures, even if based on cryptographic checksums, must have their own strong protection.</p> <p>Management and deployment costs of host-based systems are often greater than in other IDSs.</p> <p>Host-based sensors are often platform-specific, which adds cost and requires more operator expertise.</p> <p>If not deployed before system is operational, checker may miss early system compromises.</p>

### 7.2.4.3 Important Features

In selecting host-based file integrity checking scanner, a number of features should be considered. This section identifies these features; the next section discusses the rationale for choosing them.

#### Scanning Capabilities

- Monitor each OS with comprehensive files and data structures (including data structure and directories environments, such as Lightweight Directory Access Protocol [LDAP] or full X.500 services).
- Strong cryptographic checksums implemented as part of the identifier scheme.
- Centralized reporting for large enterprises.
- Built-in analysis or recommended action when modification is noticed.
- Self-checking.

- Easy specification of additional files/structures to monitor.

## Response Mechanisms

- Automated restoration of “clean” file or data structures.

## User Interfaces

- GUI for number entry, dialing status, and call results.
- Reports be viewable in real time.

## Reporting Capabilities

- Automatic alert when new, nonnetwork ports are detected.
- System answers logged in a database or file.
- Updated database of network numbers with which to compare newly identified numbers.
- Automatic combining of logged information into a report format.
- Provision of suggested mitigation approaches for discovered vulnerabilities.

## Platform Compatibility

- Platforms (OS) on which the tool will run.
- Use of executables.
- Support for scripts or macros.

### 7.2.4.4 Rationale for Selecting Scanning Features

We strongly recommend technologies that offer a comprehensive library of files and data structures for tracking that is periodically updated by the vendor. As new vulnerabilities are discovered that include files or structures that an attacker might modify, vendors should provide immediate updates.

Strong cryptography should be implemented as part of the checksum creation and recheck. Most scripted attack programs already compensate for widely known simple checksum hashing techniques and recalculate checksums. Additionally, some integrity checking technologies can now monitor static portions of directory structures, such as those found in LDAP or full X.500 directory environments.

As with host vulnerabilities, file and data structures integral to any particular OS tend to be unique to an OS or even an application. Some applications that are portable also port their vulnerabilities across platforms, and can have different vulnerabilities (characterized by different targeted files or data structures) on different platforms. And, obviously, operating structures differ drastically between the general UNIX base (and its variants), Windows 95/98, and Windows NT/2000. It is therefore critically important that the database of files and data

## UNCLASSIFIED

Detect and Respond Capabilities Within Host-Based Computing Environments  
IATF Release 3.1—September 2002

structures to monitor that is provided for the host-based integrity checker be comprehensive, adaptable, and well maintained by the vendor. We strongly recommend selecting technologies from vendors that do their own research and have specific expertise in OS vulnerabilities, rather than those that simply incorporate vulnerabilities signatures culled from other Internet-based resources.

### **Response Mechanisms**

Assessment tools will continue to evolve, with some vendors offering click-and-fix solutions. This will be true in the file integrity-checking environment as well, with some tools able to restore, from a secured backup environment, files or environments that have been illegally modified.

### **User Interfaces**

Most file checkers enable the operator to configure which files and data structures are monitored and when, although typically the checkers are preconfigured with lists of files and data structures to watch and can operate without customization. Newer tools have user-friendly front ends and sophisticated reporting capabilities.

### **Reporting Capabilities**

Usually file integrity check results are sorted into a file that can be accessed on demand. Old technologies inundated customers with phonebook-sized reports on all the vulnerabilities the network faced. New technologies have database interfaces that prioritize vulnerabilities, allowing network managers to deal with problems in a logical manner. Many generate reports that are Web-enabled, with hot-links and other labor savers. For sites with only a few platforms, running the checks and reading the reports on each node may be appropriate. For sites with large numbers of hosts, it might be wise to consolidate reports on a central server. If this feature is selected, it is recommended that technologies chosen offer encryption for information transferred from local hosts to the centralized server to protect the file integrity check information.

### **Platform Compatibility**

The computers to run this software must meet the hardware and software requirements specified by the manufacturer. File integrity checking software should perform its duties properly without failing and with minimal effect on the performance of the host.

## **7.2.4.5 Considerations for Deployment**

The decision on whether and how to deploy these programs includes understanding how often to run the integrity recheck step, whether it should be done automatically or by operator command, and where the reports are to be centralized. These all depend on the sensitivity of the information being processed and how critical that system is to the rest of the enterprise.

## 7.2.4.6 Considerations for Operation

The most important question is the timing of deployment. To be most effective, integrity checkers should be initialized before systems are placed in production and made generally accessible to their user communities. If files and data structures are baseline-monitored any time after a system has “gone live,” the system may already be compromised and the integrity checker will miss changes that have already occurred. This is particularly true in structures that are not supposed to remain static (e.g., access control databases, unlike static executables that should not change from their installed release).

## 7.2.5 Typical Bundling of Capabilities Within Products

At one point, host monitors were offered as stand-alone devices. A number of offerings now combine these monitors with firewalls, routers, vulnerability scanners, and the like, as vendors try to leverage existing market positions to gain market share in related areas. Another emerging trend is for larger vendors to offer integrated architecture approaches, bundling a number of related technologies. Vendors tend to prefer custom rather than standard interfaces to preclude the merging of other vendor offerings. These “complete solutions,” however, tend to lock the buyer into a single product suite. While this may sound attractive, it is often more valuable to be able to integrate various technologies to take advantage of the detection capabilities of different implementations.

There is a natural linkage of these monitoring technologies with enterprise security management (ESM) systems. For several years, it has been expected that host-based vulnerability assessment software will be integrated into system management platforms and that aspects of network-based products will find homes in network management platforms, but there is little evidence that this will happen in the immediate future.

## 7.2.6 Beyond Technology Solutions

While the focus of this IATF is on technology solutions, there are important operational aspects of effective network monitoring that are critical to an effective IA solution.

### Operational Planning

We recommend the following:

- Build intrusion detection and antivirus activity into the enterprise security policy.
- Assess the ability of system administration personnel to perform intrusion detection and vulnerability scanning.

## UNCLASSIFIED

Detect and Respond Capabilities Within Host-Based Computing Environments  
IATF Release 3.1—September 2002

- Consult with experienced intrusion detection and vulnerability scanning personnel about the best approach.
- Seek a balanced and symbiotic deployment of sensors.
- Consult with legal counsel about the rights and procedures of affected personnel (see below).
- Provide adequate technical and legal training of all affected personnel.
- Acquire software and expertise from a vendor of known integrity.
- Monitor networks consistent with enterprise security policy.
- Tightly couple vulnerability scanning and intrusion detection.
- In detecting intrusions—
  - Look for intrusion evidence based on found vulnerabilities; use intrusion evidence to find and correct vulnerabilities
  - Provide and monitor bogus sites, services, and information. Monitoring intrusions through known vulnerabilities may satisfy the prosecution requirements of legal authorities
  - Use intrusion responses that are approved by the appropriate authority
- In detecting network malicious code attacks—
  - Select and deploy virus scanning that is consistent with location, functions, and capabilities.
  - Acquire or download antivirus software from a high-integrity source and acquire any necessary hardware (e.g., an ancillary firewall that scans incoming or outgoing traffic for viruses).
- Institute enterprise wide antivirus procedures and training.
- Scan consistently based on time or events.
- Follow up on all indications of potential contamination (as defined in the enterprise security policy and antivirus procedures).
- Update antivirus software and hardware as needed (e.g., consistent with new releases of antiviral software and specific experiences throughout the enterprise).

### General Activities

- Archive (within any legal constraints) audit and intrusion information and correlate with vulnerability scan information.
- Keep authorities apprised of all activities, so that no legal rights are violated.
- Continuously repeat steps, as appropriate.

## Privacy Concerns

Organizations may own the intellectual property created by employees and may also legally restrict computer activities to those approved by management. A common practice is to warn all users of this as part of the normal login message.

This does not mean that all managers own all the transactions of all the employees. Especially unclear is how to handle the conflict between privacy and necessary monitoring. Use of IDSs and system-monitoring tools requires caution. Sniffers that search for key words in messages (such as “attack,” “weakness,” or “confidentiality”) as standard watchwords may find them used in an appropriate manner depending on the type of correspondence. Audit trail reports may contain full command strings (including parameters). Knowing that an employee is sending several messages to a particular department (e.g., Human Resources) may infringe on his or her privacy. It is important to refer privacy concerns to the legal and policy parts of the enterprise before technologies are deployed and used.

### 7.2.7 For More Information

The reference materials used in preparing this section (listed at the end of the section) provide an excellent base of knowledge on relevant technologies; there are also a number of other sources of information. This section deals primarily with on-line sources because they tend to offer up-to-date information.

#### 7.2.7.1 IATF Executive Summaries

An important segment of the IATF is a series of executive summaries that offer implementation guidance for specific situations. These offer important perspectives on the realistic operation of specific technologies. As these are formulated, they will be posted on the IATF Web site <http://www.iatf.net>. [1]

#### 7.2.7.2 Protection Profiles

National Security Telecommunications and Information Systems Security Policy (NSTISSP) No. 11 sets out the national policy that governing the acquisition of IA and IA-enabled IT products for national security telecommunications and information systems. Effective January 2001, preference was to be given to products that comply with one of the following:

- International Common Criteria for Information Security Technology Evaluation Mutual Recognition Arrangement.
- National Security Agency (NSA)/National Institute of Standards and Technology (NIST) National Information Assurance Partnership (NIAP).
- NIST Federal Information Processing Standard (FIPS) validation program.



## UNCLASSIFIED

Detect and Respond Capabilities Within Host-Based Computing Environments  
IATF Release 3.1—September 2002

Since January 2002, this requirement is mandated. Department of Defense (DoD) Chief Information Officer (CIO) Guidance and Policy Memorandum No. 6-8510, Guidance and Policy for Department of Defense Global Information Grid Information Assurance incorporates NSTISSP No. 11 as an acquisition policy for the DoD.

The International Common Criteria and NIAP initiatives base product evaluations on Common Criteria protection profiles. NSA and NIST are working on a comprehensive set of protection profiles. An overview of these initiatives, copies of the protection profiles, and status of various products that have been evaluated are available at the NIST Web site, <http://niap.nist.gov/>. [2]

### 7.2.7.3 Independent Third Party Reviewers of Technologies

ICSA Net Security Page, [www.icsa.net](http://www.icsa.net).

Talisker's Intrusion Detection Systems, [www.networkintrusion.co.uk/](http://www.networkintrusion.co.uk/).

Network Computing—The Technology Solution Center, [www.nwc.com/1023/1023f12.html](http://www.nwc.com/1023/1023f12.html).

Paper on CMDS Enterprise 4.02, <http://www.Intrusion.com/Products/enterprise.shtml> (ODS Networks has changed its name to Intrusion.com).

Paper on CMDS Enterprise 4.02, <http://www.Intrusion.com/Products/enterprise.shtml> (ODS Networks has changed its name to Intrusion.com).

PC Week On-Line, [www.zdnet.com/pcweek/reviews/0810/10sec.html](http://www.zdnet.com/pcweek/reviews/0810/10sec.html).

### 7.2.7.4 Relevant Research Sites

Coast Homepage—Purdue University, [www.cs.purdue.edu/coast](http://www.cs.purdue.edu/coast).

University of California (UC) Davis, <http://seclab.cs.ucdavis.edu/>

### 7.2.7.5 Selected Host Monitor and Scanner Vendors

Axent Technologies, [www.axent.com](http://www.axent.com).

cai.net, <http://www.cai.net/>.

Cisco Connection Online, [www.cisco.com](http://www.cisco.com).

CyberSafe Corporation, [www.cybersafe.com](http://www.cybersafe.com).

**UNCLASSIFIED**

Detect and Respond Capabilities Within Host-Based Computing Environments  
IATF Release 3.1—September 2002

Internet Security Systems, [www.iss.net](http://www.iss.net).

Network ICE, [www.networkice.com](http://www.networkice.com).

## UNCLASSIFIED

Detect and Respond Capabilities Within Host-Based Computing Environments  
IATF Release 3.1—September 2002

### References

1. Information Assurance Technical Framework (IATF), <http://www.iaf.net>.
2. National Institute of Standards and Technology, <http://niap.nist.gov/>.

### Additional References

- a. Amoroso, Edward, Intrusion Detection. Intrusion.Net Books, 1999.
- b. AXENT Technologies, Inc. Intruder Alert 3.5 IDS Review Guide, May 2000.
- c. AXENT Technologies, Inc. *Everything You Need to Know About Intrusion Detection*, 1999.
- d. Balasubramaniyan, J. S., et al. An Architecture for Intrusion Detection Using Autonomous Agents. COAST Technical Report. 11 June 1998.
- e. Concurrent Technologies Corporation. Attack Sensing, Warning, and Response (ASW&R) Baseline Tool Assessment Task Anti-Virus Trade Study Report. Report No. 0017-UU-TE-000623. 13 April 2000.
- f. Concurrent Technologies Corporation. Attack Sensing, Warning, and Response (ASW&R) Trade Study Report Intrusion Detection System. Report No. 0017-UU-TE-000621. 14 April 2000.
- g. Department of Defense (DoD) Chief Information Officer (CIO) Guidance and Policy Memorandum No. 6-8510, Guidance and Policy for Department of Defense Global Information Grid Information Assurance.
- h. Escamilla, Terry. Intrusion Detection, Network Security Beyond the Firewall. Wiley Computer Publishing, 1998.
- i. Graham, Robert. "New Security Trends for Open Networks." SC Magazine, October 1999.
- j. Information Assurance Technology Analysis Center (IATAC). Tools Report on Intrusion Detection. Defense Technical Information Center. December 1999.
- k. Information Assurance Technology Analysis Center (IATAC). Tools Report on Vulnerability Analysis Information. Defense Technical Information Center. 15 March 2000.
- l. Maes, V. "How I Chose an IDS." Information Security Magazine. Volume 2, Number 9. September 1999.
- m. National Security Telecommunications and Information Systems Security Policy (NSTISSP) No. 11. National Policy Governing the Acquisition of Information Assurance (IA) and IA-Enabled Information Technology (IT) Products. January 2000.
- n. Northcutt, Stephen. Network Intrusion Detection, An Analyst's Handbook. New Riders Publishing, 1999.

## UNCLASSIFIED

Detect and Respond Capabilities Within Host-Based Computing Environments  
IATF Release 3.1—September 2002

- o. SC Magazine. “Intrusion Detection.” June 2000.
- p. Schneider, Sondra, et al. “Life After IDS.” Information Security Magazine. Volume 2, Number 9, September 1999.
- q. Snapp, Steven R., et al. A System for Distributed Intrusion Detection. IEEE CH2961-1/91/0000/0170, 1999.
- r. Ulsch, MacDonnell, and Joseph Judge. “Bitter-Suite Security.” Information Security Magazine. 2, # 1. January 1999.

**UNCLASSIFIED**

Detect and Respond Capabilities Within Host-Based Computing Environments  
IATF Release 3.1—September 2002

**This page intentionally left blank**

## Chapter 8

# Supporting Infrastructure

---

A principal tenet of the Defense-in-Depth philosophy is to provide defenses against cyber intrusions and attacks, and deal effectively with and recover from attacks that penetrate those defenses. The supporting infrastructures are a set of interrelated activities and infrastructures providing security services to enable and manage the framework's technology solutions. Currently, the Defense-in-Depth strategy defines two supporting infrastructures:

- **Key Management Infrastructure/Public Key Infrastructure (KMI/PKI).** For the generation, distribution, and management of security credentials, such as keys and certificates.
- **Detect and Respond.** For providing warnings, detecting and characterizing suspected cyber attacks, coordinating effective responses, and performing investigative analyses of attacks.

Today's information infrastructures are not sufficiently secure to provide the full range of services needed to defend against the threats anticipated for the Global Information Grid (GIG). Thus, the Defense-in-Depth strategy provides overlays of information assurance (IA) features to realize an effective defense. Key management (including public key management) is fundamental to many IA protection technologies. Because our ability to provide airtight protection is neither technically nor economically feasible, we must reinforce those protection technologies with capabilities to detect, respond to, and recover from cyber attacks that penetrate those protections.

Cryptography-enabled services rely on KMI or PKI to provide a trustworthy foundation. The KMI/PKI supporting infrastructure focuses on the technologies, services, and processes used to manage public key certificates and symmetric cryptography. As shown in Figure 8-1, the KMI/PKI infrastructure touches most portions of the networked environment.

KMI/PKI hardware and software at the enclave level provide local authorities (e.g., KMI managers) with capabilities to order and manage KMI/PKI products and services, issue certificates, and generate traditional symmetric keys. KMI at the wide area network (WAN) level provides certificate, directory, and key generation and distribution functions.

The PKI strategy is based heavily on multiple levels of assurance because it is not cost effective to provide high-assurance protection for all PKI-enabled services. High assurance is needed when public key capabilities are used as the primary means to protect national security information. For other services, a medium-assurance PKI is appropriate based on commercial technology. The medium-assurance PKI will initially use software-based end-user tokens, but it will evolve to the use of hardware tokens.

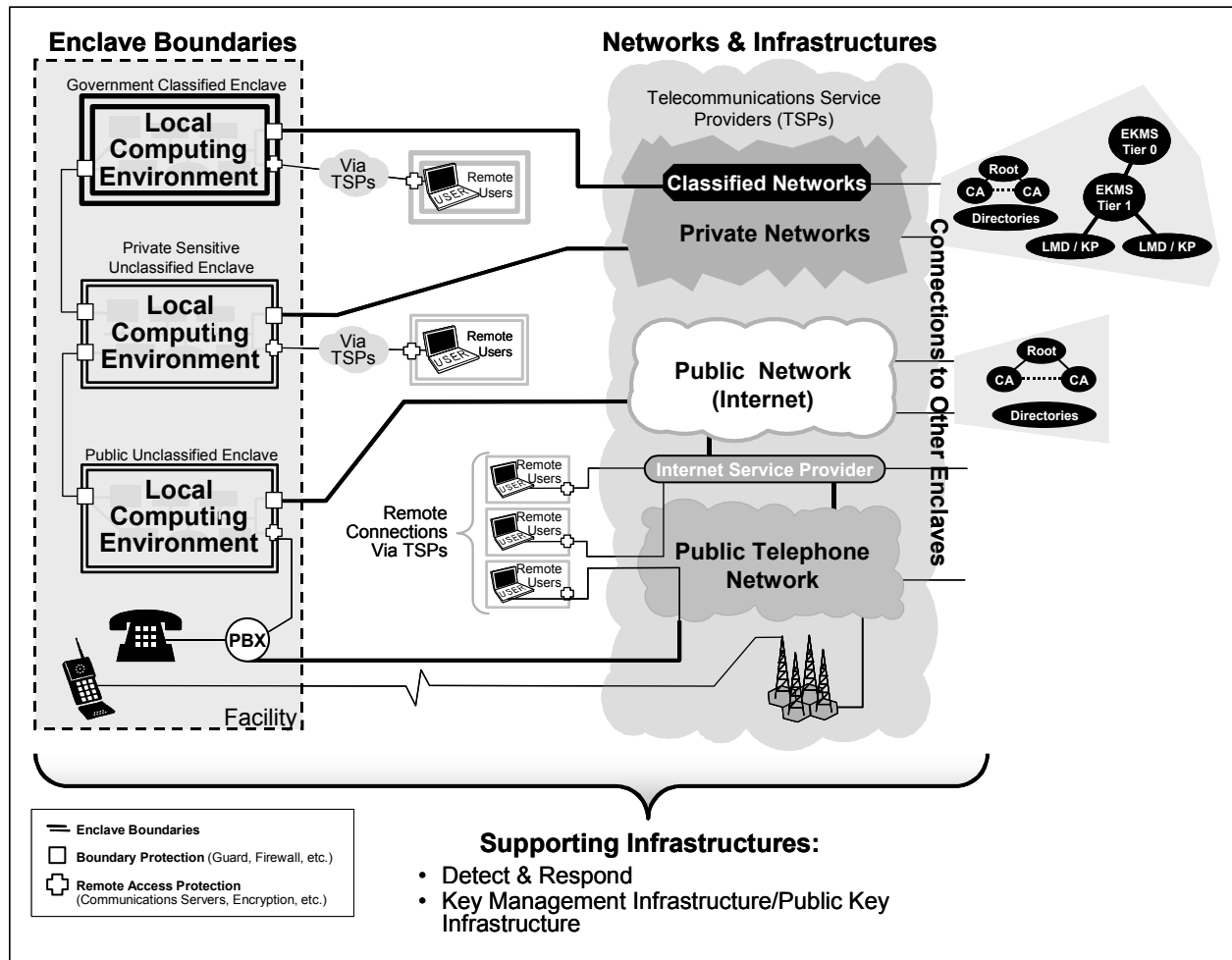

Figure 8-1. Supporting Infrastructures: KMI/PKI

Because a major feature of a PKI is to provide widespread interoperability and a broad base of noninteroperable commercial PKI technology solutions exists on the market today, we recommend a foundational PKI be fielded quickly so that other efforts can build on it. The PKI should support interoperability with external federal, foreign, and public domains. One way to achieve interoperability is through cross-certification. Further study is required to decide where cross-certification is best used. With PKI technology still immature and changing rapidly, the strategy for fielding a large-scale PKI quickly should be to make it a simple infrastructure that provides only basic cryptographic capabilities, including digital identifications (ID), compromise recovery, key recovery, and archive. Departments, agencies, and corporations are then free to build atop this infrastructure for capabilities such as access control.

It is unclear whether the higher assurance PKI is best operated by corporate personnel or outsourced. Numerous government organizations (including a major effort by the Department of Defense [DoD]) deploy and operate PKI pilots to gather operating information to evaluate its impact on mission (and business) performance and assess whether portions should be outsourced.

The local environments will maintain the option of deploying sensors, and possibly analysts to interpret the results of, and, when appropriate, react to the implications of these outputs. Beyond the local environment, each organization, or perhaps community, must determine what information should be reported, in what format, under what situations, and to whom.

While planning for a Detect and Respond infrastructure, it is important to recognize that the enterprise networks and systems that it will support must also be structured to provide information to, and take advantage of, the services and information that the infrastructure provides. This section provides good engineering practices for an enterprise to enhance its Detect and Respond capability.

When considering a general construct for a Detect and Respond infrastructure, a primary consideration is the perspective that the infrastructure will provide for its support. The reality is that most infrastructures are inherently hierarchical, and this one is no exception. Often information about incidents, which is usually sensed at the lowest layer in the hierarchy, is promulgated up to higher layers with some form of reporting. Warning and response coordination that are more typically derived from higher layers are disseminated from those higher layers down.

A wide range of functions is needed to support Detect and Respond, and technology solutions are not available to automatically perform many of these functions. Thus, analysts, network operators, and system administrators who apply basic support technologies to ease their tasks perform many of these functions. To deal with this issue from a technology viewpoint, we identify the functions that these analysts (and their tools) are attempting to perform, and then discuss the technologies that are available to realize these functions.

The Detect and Respond infrastructure element provides the functional and management capabilities to provide warning alerts of possible upcoming cyber attacks, and to assist local environments to detect, characterize, respond to, and recover from attacks. Figure 8-2 highlights the areas of the high-level Defense Information Infrastructure (DII) context that comprise the detect and respond infrastructure.

Because the local environments are the logical location for sensors, the network-based sensor functions are discussed in Chapter 6, Defend the Enclave Boundary/External Connections, and their host-based counterparts are covered in Chapter 7, Defend the Computing Environment. We recognize that local environments have the option to implement as much or as little as they believe is prudent, obtaining services and support from the infrastructure. Detect and Respond processes and functions in the context of the supporting infrastructure are the focus of this section.



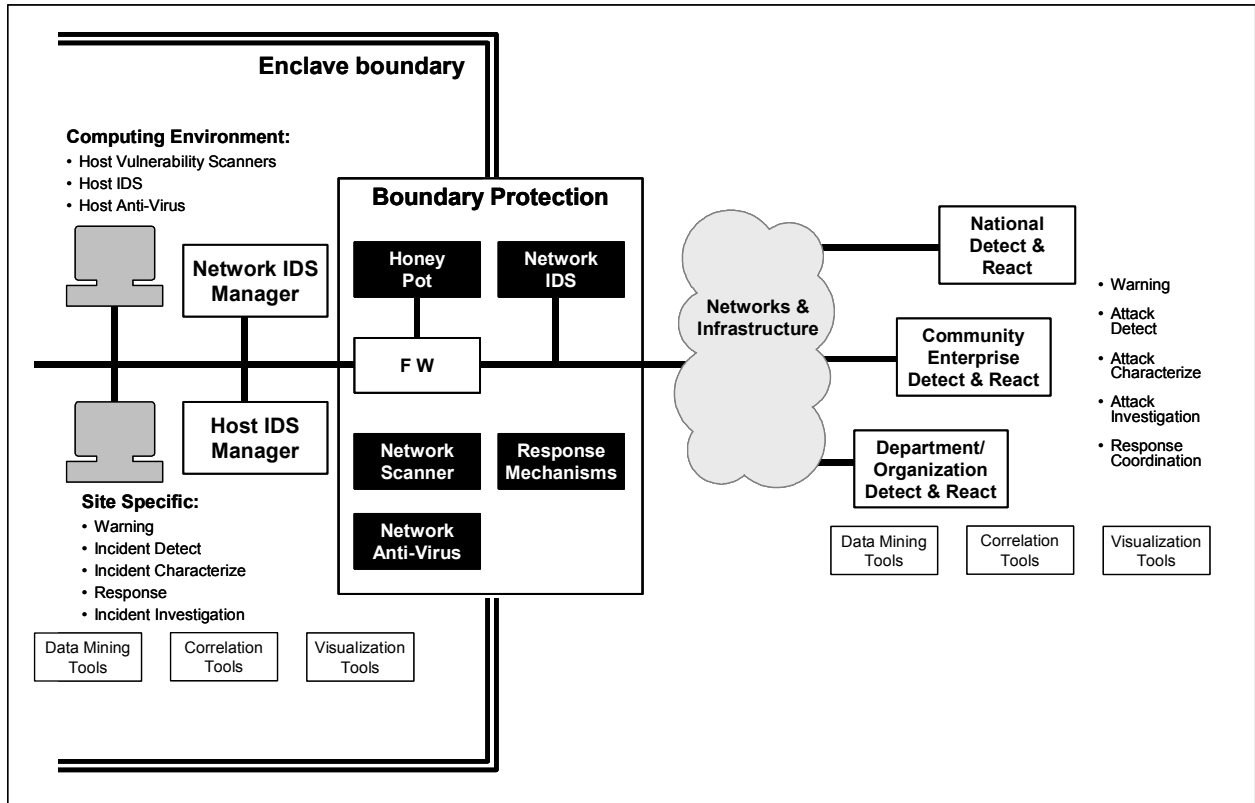

iatf\_8\_2\_0061

Figure 8-2. Supporting Infrastructures: Detect and Respond

## 8.1 Key Management Infrastructure/ Public Key Infrastructure

This section focuses on management of the Supporting infrastructure. Following introductory tutorial information, Public Key Infrastructure (PKI) certificate management, symmetrical key management, directory management, and infrastructure management will be highlighted. Each of the process discussions is self-contained; therefore, the reader can review only those Key Management Infrastructure (KMI)/PKI services and processes that are of interest. They will include specific requirements applicable to that process and KMI/PKI service, important threats and countermeasures, and the range of technologies used to implement the process. Table 8.1-3 defines at a high level, the way each process relates to the various KMI/PKI services. The remainder of the section presents a range of KMI/PKI solutions used by or planned for protected networks.

### 8.1.1 KMI/PKI Introduction

KMI/PKI is unique in its framework because it does not directly satisfy subscriber's security requirements; instead, it forms building blocks used by other security technologies. The KMI/PKI is an enabler; however, the KMI/PKI architecture is heavily dependent on the specific applications it supports. Table 8.1-1 relates the subscriber categories described in Chapters 5, Defend the Network and Infrastructure and 6, Defend the Enclave Boundary/External Connections, of the framework and to the required KMI/PKI services. For example, a virtual private network (VPN) provides an encrypted pipe between two enclaves. The KMI/PKI infrastructure supplies keys and certificates to the cryptographic devices that provide authentication and encryption. Additional services might include key recovery and a directory to provide access to subscriber's public certificates.

**Table 8.1-1. KMI/PKI Services Support to Subscriber Categories**

Subscriber Category	KMI/PKI Service			
VPN	Key generation	Certificate management	Key recovery	Directory
Network Access	Key generation	Certificate management	Value-added services	Directory
Remote Access	Key generation	Certificate management	Key recovery	Directory
Multilevel Security	Key generation	Certificate management	Directory	

Another area in which KMI/PKI differs from the Framework's other solutions is that it distributes its security throughout a number of separate elements. These elements require extensive security (e.g., encryption, certificate management, compromise recovery) among themselves to protect the subscriber's key or certificate. Because of the repercussions of a successful attack against the KMI/PKI, internal infrastructure security requirements are often

more stringent than those required by subscriber applications. There are unique requirements on the infrastructure (e.g., policy management) and the level of security assurance for infrastructure components is usually higher than for subscriber applications.

### 8.1.1.1 KMI/PKI Services

Current KMI/PKI implementations consist of several stovepipe infrastructures from different organizations, supplying different subscriber solutions. The end subscriber may need support from several of the stovepipes for a single application. Today, subscribers have to contact each infrastructure separately to get service. High cost, dwindling manpower, and higher subscriber expectations are pressuring a merger of these stovepipes into larger infrastructure elements supporting multiple subscriber requirements.

This chapter discusses four of the operational services supplied by the KMI/PKI supporting infrastructure. These KMI/PKI services support many subscriber applications and consequently employ different (but related) mechanisms and have unique security requirements. The first two services describe functions that directly support subscriber applications. The last two services are functions required by the subscriber functions to work properly.

The first KMI/PKI service is symmetric key generation and distribution. This is still the primary key management mechanism within the government classified community. The banking community, with its extensive use of the data encryption standard (DES) encryption, is another major user of symmetric key management. Although symmetric key is being replaced by asymmetric key agreement in many applications, it has application outside the government classified community in such areas as multicast and low-bandwidth applications (e.g., wireless). Symmetric key management is a process in which a central element (it could be one of the subscribers or a trusted independent element) generates, distributes, and manages a “secret key” for multiple recipients. Each recipient uses the same secret key for security processing between itself and the other recipients for the life of the key.

The second KMI/PKI service is support for asymmetric cryptography (often called public key cryptography) and its associated certificate management. Asymmetric cryptography usually employs digital certificates to allow subscribers to authenticate the public portion of the asymmetric cryptography public and private key pairs. This authentication is important because the security services that asymmetric cryptography provides depend on the subscriber of a public key (called the relying party) being assured that the public key is associated with a specific identified subscriber. Digital certificates (often called X.509 certificates, after the international standard which defines their format) cryptographically bind identities to public keys. Together, the components, personnel, facilities, services, and policies that are used to generate and manage public key certificates define a PKI. PKIs can generate and manage digital signature certificates (used for authentication, data integrity, and nonrepudiation) and key management certificates (used for confidentiality). The commercial community relies heavily on public key cryptography, and commercial vendors offer a wide variety of PKI products and services.

The third KMI/PKI service is directory service. Directory servers provide access to the public information required with PKI, such as the public certificate, the related infrastructure certificates, and the compromised key information. Directory services can be provided either by a global set of distributed directories (e.g., X.500 Defense Message System [DMS] directories) or by an online repository at a single site. Directories are normally very closely coupled with PKI, but are also used for other services.

The final KMI/PKI service is managing the infrastructure itself. The other infrastructure architectures discussed in this section consist of a number of elements working together to provide the subscriber service. The distributed nature of the infrastructure places additional functional and procedural requirements on the KMI/PKI and the sensitivity of the application places additional security requirements on the KMI/PKI. The internal structure of the infrastructure varies with the application(s) it supports. For example, the level of assurance demanded by the applications dictates many of the internal aspects of the KMI/PKI.

### 8.1.1.2 Security Applications

The security applications supported by the KMI/PKI differ depending on the type of cryptography that is being used by the application. Symmetric cryptography primarily provides confidentiality services for data transmission and storage. It can also support other mechanisms such as transmission security (TRANSEC) (e.g., spread spectrum), or in combination with additional mechanisms, data integrity, and authentication during data transmission. Public key cryptography in conjunction with certificate management provides a full range of security services. Unlike symmetric cryptography, it can provide authentication and integrity for data transmission and data storage. Although it can encrypt information, this process is extremely inefficient and is normally provided by a symmetric algorithm. Table 8.1-2 describes the security applications that each type of cryptographic algorithm supports.

**Table 8.1-2. Security Applications Supported By Cryptographic Type**

Security Application	Symmetric Cryptography	Asymmetric Cryptography
Authentication	*	X
Nonrepudiation	*	X
Transmission Confidentiality	X	
File Encryption	X	
Integrity	*	X
Availability (e.g., Spread Spectrum)	X	
Key Agreement		X

\*These services can be enabled by symmetric cryptography when provided in conjunction with other mechanisms (e.g., a cyclic redundancy check [CRC] encrypted with the message).

### 8.1.1.3 Infrastructure Process

The KMI/PKI consists of numerous processes that all have to work together correctly for the subscriber service to be secure. Each process is necessary at some level in all KMI/PKI architectures. These processes are listed below:

- **Registration**—Enrolling those individuals who are authorized to use the KMI/PKI.
- **Ordering**—Requesting the KMI/PKI to provide a subscriber either a key or a certificate.
- **Key Generation**—Generating the symmetric or asymmetric key by an infrastructure element.
- **Certificate Generation**—Binding the subscriber information and the asymmetric key into a certificate.
- **Distribution**—Providing the keys and certificates to the subscribers in a secure, authenticated manner.
- **Accounting**—Tracking the location and status of keys and certificates.
- **Compromise Recovery**—Removing compromised keys and invalid certificates from the system in an authenticated manner.
- **Rekey**—Replacing periodically the keys and certificates in a secure, authenticated manner.
- **Destruction**—Destroying the secret key when it is no longer valid.
- **Key Recovery**—Recovering subscriber's private encryption key without direct access to the subscriber's copy of the key.
- **Policy Creation**—Defining the requirements for employment of the previous processes.
- **Administration**—Running the infrastructure.
- **Value-added PKI Processes**—Supporting optional value-added processes, including archive, time stamp, and notary services. Because all PKI architectures do not support these features, this section will not discuss them further.

The complete set of KMI/PKI processes is usually allocated to several elements performing independent tasks that require extensive coordination between elements. For most of the processes, numerous ways exist to implement the services based on the application supported; the security required; and the cost (e.g., money, people, and performance) the subscriber would be willing to pay. Each process contributes to the overall security of the KMI/PKI and has different forms of attacks and countermeasures. Table 8.1-3 defines the basic requirements for implementing each process for the four KMI/PKI services. Figure 8.1-1 depicts the interaction of these services.

**Table 8.1-3. KMI/PKI Processes**

<b>Process</b>	<b>Certificate (Public Key) Management, Section 8.1.2</b>	<b>Symmetric Key Management, Section 8.1.3</b>	<b>Infrastructure Directory Services, Section 8.1.4</b>	<b>Infrastructure Management, Section 8.1.5</b>
<b>Policy Creation</b>	N/A	N/A	N/A	Define domain's policy and method for enforcing the policy
<b>Registration</b>	Register people who can authorize subscribers	Register people authorized to order key	Register people authorized to update directory	Define process of authorizing changes to the infrastructure's trust model (e.g., new elements, cross-certification)
<b>Ordering and Validation</b>	<ul style="list-style-type: none"> <li>Validate the information in the certificate</li> <li>Validate the key generation request</li> <li>Receive the public key</li> </ul>	Validate order	Validate the information request	<ul style="list-style-type: none"> <li>Validate process for changes to the trust model</li> <li>Receive the public key of the infrastructure elements</li> </ul>
<b>Generation</b>	<ul style="list-style-type: none"> <li>Generate the public/private key pairs</li> <li>Generate the certificate</li> </ul>	Generate key	Add information to the directory	<ul style="list-style-type: none"> <li>Generate the root public/private keys</li> <li>Generate the root certificate</li> <li>Generate the infrastructure elements public/private keys</li> <li>Generate the infrastructure elements certificates</li> <li>Generate the cross-certificates</li> </ul>
<b>Distribution</b>	<ul style="list-style-type: none"> <li>Provide the certificate to the subscriber</li> <li>Validate that the person getting the certificate has the private key corresponding to the bound public key</li> <li>Provide the Policy Approving Authority (PAA) public certificate to the subscriber in an authenticated manner</li> </ul>	<ul style="list-style-type: none"> <li>Deliver the key to the Custodian</li> <li>Load the key into the cryptographic device</li> </ul>	Provide information to subscriber	<ul style="list-style-type: none"> <li>Provide the root certificate to each infrastructure element in an authenticated manner</li> <li>Provide each element with its certificates</li> <li>Validate that each infrastructure element has the private key corresponding to the public key</li> <li>Provide each element with the domain's cryptographic parameters in an authenticated manner</li> </ul>

**UNCLASSIFIED**

Key Management Infrastructure/Public Key Infrastructure  
 IATF Release 3.1—September 2002

<b>Process</b>	<b>Certificate (Public Key) Management, Section 8.1.2</b>	<b>Symmetric Key Management, Section 8.1.3</b>	<b>Infrastructure Directory Services, Section 8.1.4</b>	<b>Infrastructure Management, Section 8.1.5</b>
<b>Compromise Recovery</b>	<ul style="list-style-type: none"> <li>• Provide Compromise Key List (CKL) of compromised keys</li> <li>• Provide online validation of the liveness of certificates</li> </ul>	Provide supersession of all devices using the compromised key	Fix a hacked directory	Provide procedures for reconstituting the infrastructure in case of disaster or compromise of any infrastructure element
<b>Accounting</b>	Track the location and status of key and certificates throughout life cycle	Track the location and status of key throughout life-cycle	Audit who makes changes to the information in the directory	Ensure that the infrastructure elements operate within the policies and procedures defined by the PAA
<b>Key Recovery</b>	Appropriate key recovery mechanisms	N/A	N/A	Root signature key might need key recovery?
<b>Rekey</b>	<ul style="list-style-type: none"> <li>• New certificate</li> <li>• New key</li> </ul>	Rekey the cryptographic device	N/A	Process for changing the root key(s)
<b>Destruction</b>	Zeroize private key at the conclusion of use	Zeroize key at the conclusion of the cryptoperiod	Remove information from the directory	Zeroize the infrastructure elements private key at the conclusion of use
<b>Administration</b>	N/A	N/A	N/A	Provide procedures for operating the infrastructure securely and enforcing the system policies

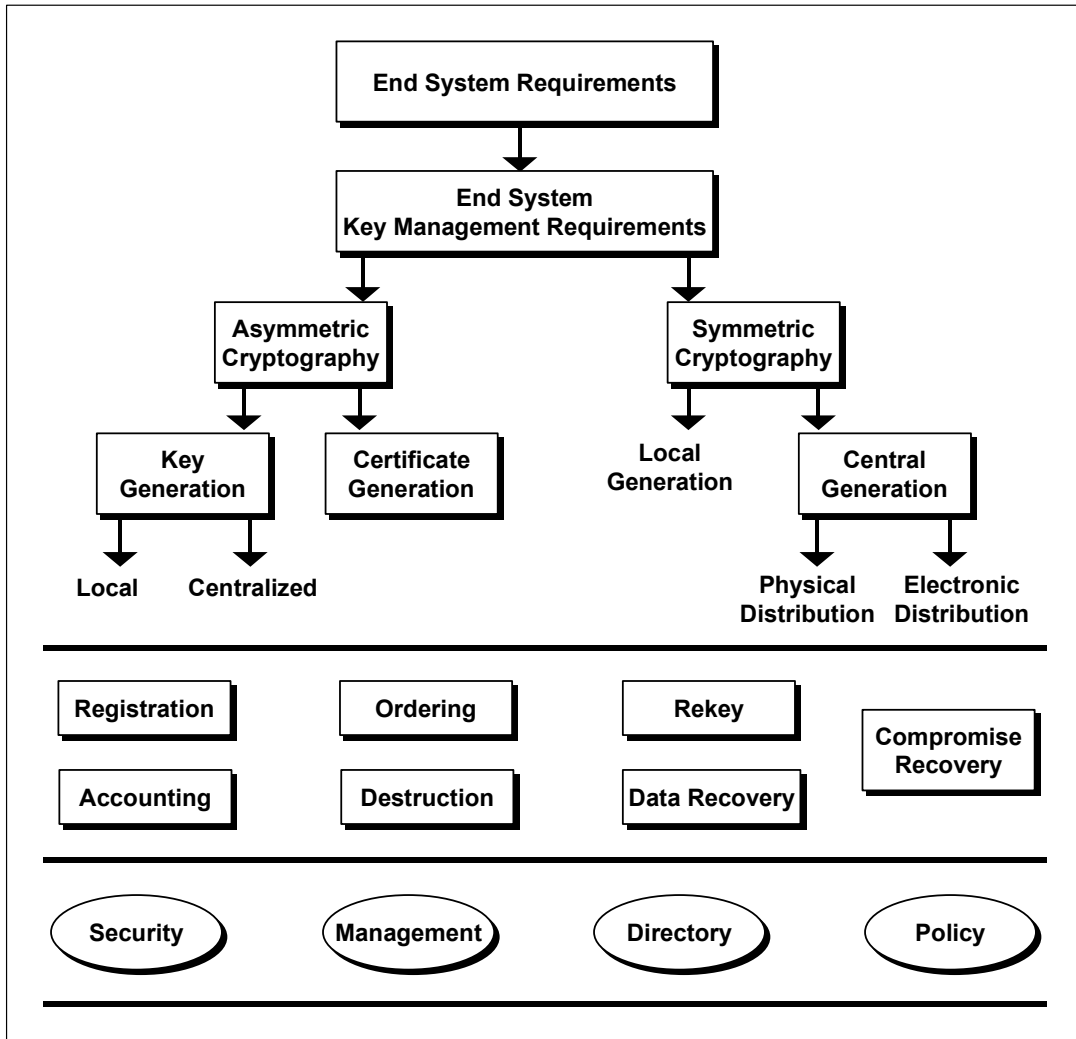

iatf\_8\_1\_1\_0040

Figure 8.1-1. Interactions of the KMI/PKI Applications Operational Services

### 8.1.1.4 Requirements

This section includes subscriber and infrastructure requirements. Because of the variety of issues involved in KMI/PKI, no single set of requirements can be consistent and complete for all applications. This paragraph outlines some of the high-level requirements. It consists of both functional and operational requirements. Unlike most of the subscriber requirements identified in the Framework, the KMI/PKI has a large operational component. Once initialized, most subscriber solutions need little or no subscriber interaction (e.g., once the VPN has deployed the cryptographic device, the only update is the KMI/PKI task of rekeying periodically). The KMI/PKI, on the other hand, requires extensive human interaction throughout its processing. This close coupling of people and service place additional requirements on the KMI/PKI that have implications on the security solution.



### **8.1.1.4.1 Subscriber Requirements**

#### **Symmetric Cryptography**

- The key comes from an approved, authorized, authenticated source.
- The key is protected during distribution.

#### **Asymmetric Cryptography**

- The subscriber or the KMI/PKI shall generate the public and private key pair.
- The certificate information is accurate and current, and it reflects a valid association with a uniquely identified subscriber.
- The certificate binds the public key associated with the subscriber's private key with the subscriber's identification.
- The trusted element's certificate is distributed to the subscriber in an authenticated manner.
- The subscriber can determine the current status of certificates in a timely manner.
- The KMI/PKI only provides a copy of a private key to authorize data recovery entities as defined by policy (e.g., subscriber or subscriber's organization).

### **8.1.1.4.2 Infrastructure Management Requirements**

#### **Symmetric Cryptography**

- Symmetric cryptography ensures that requests for key generation or distribution come from only authorized sources.
- Key generation is secure and robust.
- The delivery mechanism protects the key from compromise.
- Key is distributed to only authorized subscribers.
- The system accounts for key during its entire life cycle (ordering, generation, distribution, use, rekey, and destruction).
- The infrastructure removes compromised keys from the system.

#### **Asymmetric Cryptography**

- Asymmetric cryptography ensures that a request for a certificate comes from an authorized source.
- Before generating the certificate, the system ensures that the information in the certificate corresponds to the requesting subscriber.
- The certification authority (CA) places the correct public key into the certificate.

- If the infrastructure generates the private key agreement key, it is generated and transmitted securely to the subscriber.
- The infrastructure must ensure integrity and provide its certificates in an authenticated nonrepudiated manner to each subscriber.
- The infrastructure must provide compromise information to subscribers in a timely manner.
- The infrastructure must ensure high assurance in the registration of infrastructure elements.
- The system accounts for the life cycle of key (ordering, generation, distribution, application, rekey, destruction, and archive).
- The key recovery mechanism of the KMI/PKI only provides access to the private key to authorized entities (e.g., subscriber's organization).
- The key must be protected by the key recovery mechanism of the KMI/PKI during storage.
- The recovered key must be protected during distribution to the subscriber.

### 8.1.1.4.3 Interoperability Requirements

**NOTE:** Interoperability of the key management cryptographic infrastructure does not guarantee subscriber application interoperability.

#### Symmetric Cryptography

- Keys and compromise information can be distributed to all subscribers.
- Format of the key must be the same for all subscribers.
- Algorithms and initial parameters must be the same for all subscribers.

#### Asymmetric Cryptography

- When cross-certifying, the policies must be approved by each PKI.
- The subscriber may need to accept certificates from multiple domains.
- The infrastructure may need to support multiple algorithms and offer the subscriber the choice of algorithm to sign the certificate.
- The format of the keys and certificates must be the same for all subscribers (e.g., certificate profiles, use of X.509).
- Algorithms and initial parameters must be the same for all subscribers.
- Compromise recovery information must be available to all subscribers.

### 8.1.1.5 Attacks and Countermeasures

The goal of any attack against the infrastructure is to use it as a basis for attacking a subscriber's environment. Attacking the infrastructure does not provide an adversary with the subscriber's information (beyond audit information that may be archived), but it may be used as a basis for a further attack against the subscriber. An attacker may directly target the information provided by the infrastructure (e.g., symmetric key, certificate) or may attack the infrastructure elements in order to later attack a subscriber (e.g., place a Trojan horse in an infrastructure element to substitute a known key for the subscriber's valid key). Table 8.1-4 lists several interesting attacks and potential countermeasures.

**Table 8.1-4. Attacks and Countermeasures**

Attacks Against User Via Infrastructure Support	Attacks Against Infrastructure	Countermeasures
Compromise data [Read traffic resulting from weak cryptography (compromised, weak keys)] Masquerade (get a certificate with false information) Denial of service (prevent signature from verifying [e.g., attack directories]) Man-in-the-middle attack	Violate trust model (e.g., generate an unauthorized cross-certification_ Acquire unauthorized certificate (e.g., insider, incorrect identification) Force subscriber to have weak key (e.g., known key, failed randomizer) Deny by —attacking directories (denial of service) Compromise key during distribution Gain unauthorized access to key recovery key Compromise personal identification number (PIN) to gain access to subscribers private key (generation, distribution, use) Prevent subscriber from determining compromise status during validation Substitute the attacker's public key for the subscriber's public key Place malicious software into infrastructure elements Wage cryptanalytic attack against the PKI's private keys	Use security features of the protocols (e.g., name constraints, policy mapping) Provide proper management of the infrastructure Provide multiperson control on the certificate approval and generation process Provide protected distribution (e.g., benign fill) Provide robust compromise recovery Use tokens to generate and protect private keys Require high-assurance operating systems in infrastructure components Require strong authentication on infrastructure services (e.g., directories and key recovery) Coordinate certificate request content with the security officer, personnel officer, authorization officer, and privilege assignment officer Independently certify the content of certificates against the officially approved certificate requests

## 8.1.2 Certificate Management

A primary function of KMI/PKIs is the generation, management, and distribution of asymmetric key material and certificates used within a variety of public key-based applications. The portion of the KMI/PKI dedicated to the management of keys and certificates is the PKI. This section provides an overview of the architecture and the processes or functions associated with PKIs. The section also discusses the threats and countermeasures specific to PKIs. This section is written from the perspective of PKI subscribers versus that of PKI administrators. The administrative perspective is discussed in Section 8.1.5.12, Administration.

### 8.1.2.1 Public Key Infrastructure Services

To support the wide variety of public key-based applications, a PKI employs a diverse set of software and hardware components, protocols, and message formats. The primary components of the PKI are CAs, registration authorities (RA), and certificate repositories. The primary products of the PKI include asymmetric key material, certificates, and Certificate Revocation Lists (CRL). A brief description of these components is provided below.

- **CA.** An authority trusted by one or more subscribers to create and assign certificates. [ISO9594-8] The individual operating the CA equipment is referred to as a CA operator.
- **RA.** A trusted entity responsible for performing tasks, such as authenticating the identity of subscribers requesting certificates on behalf of a CA. The RA neither signs nor issues certificates. Usually, RAs are located at the same location as the subscribers for which they perform authentication. The individual functioning in this role is referred to as the RA operator. Many PKIs distribute the RA functions to Local Registration Authorities (LRA) to provide subscribers with convenient PKI services.
- **Certificate Repository.** The location where a CA posts the certificates and CRLs that it generates so that they are available to PKI subscribers. Repositories can take many forms, including databases and Web servers, but are commonly directories that are accessible using the Lightweight Directory Access Protocol (LDAP).
- **Asymmetric Key Material.** In asymmetric or public key cryptography, two different cryptographic keys are used. One key is used to encrypt or sign data, whereas the other is used to decrypt or verify data. The “private” key is kept secret to the entity generating the key. The “public” key, which is computed from the private key using a mathematical one-way function, is made public. Because it is mathematically infeasible to compute the private key from the public key, knowledge of the public key does not imply knowledge of the private key.
- **Certificates.** A computer-based record that binds a subscriber’s identity (and some authorizations) with his or her public key in a trust association. The certificate identifies the issuing CA, identifies its subscriber, contains the subscriber’s public key, and is digitally signed by the issuing CA. Often, these certificates comply with the International Telecommunications Union (ITU) X.509 standard. Such certificates are called *X.509 certificates*. [1]
- **CRL.** A list containing certificates still within their validity interval, but which no longer represent a valid binding between a public key and a particular identity. CRLs are

created by a CA, and include the certificates revoked by that CA. CRLs may be posted to a repository or may be distributed through another mechanism (e.g., Web and e-mail). Other means for obtaining certificate status, such as Online Certificate Status Protocol, are also sometimes employed instead of CRLs.

Figure 8.1-2 overlays PKI components within a generic security architecture PKI associated with commercial entities, federal partners, and non-federal partners, which are shown along the right-side of the figure. Even though the figure shows federal subscribers obtaining PKI services from federal agency PKIs, federal agencies will often obtain PKI services from commercial providers. Subscribers operating from secure network enclaves (normally, a local area network [LAN] connected to the Internet via a firewall) work with RAs who confirm subscriber identities to obtain certificates from remote CAs.

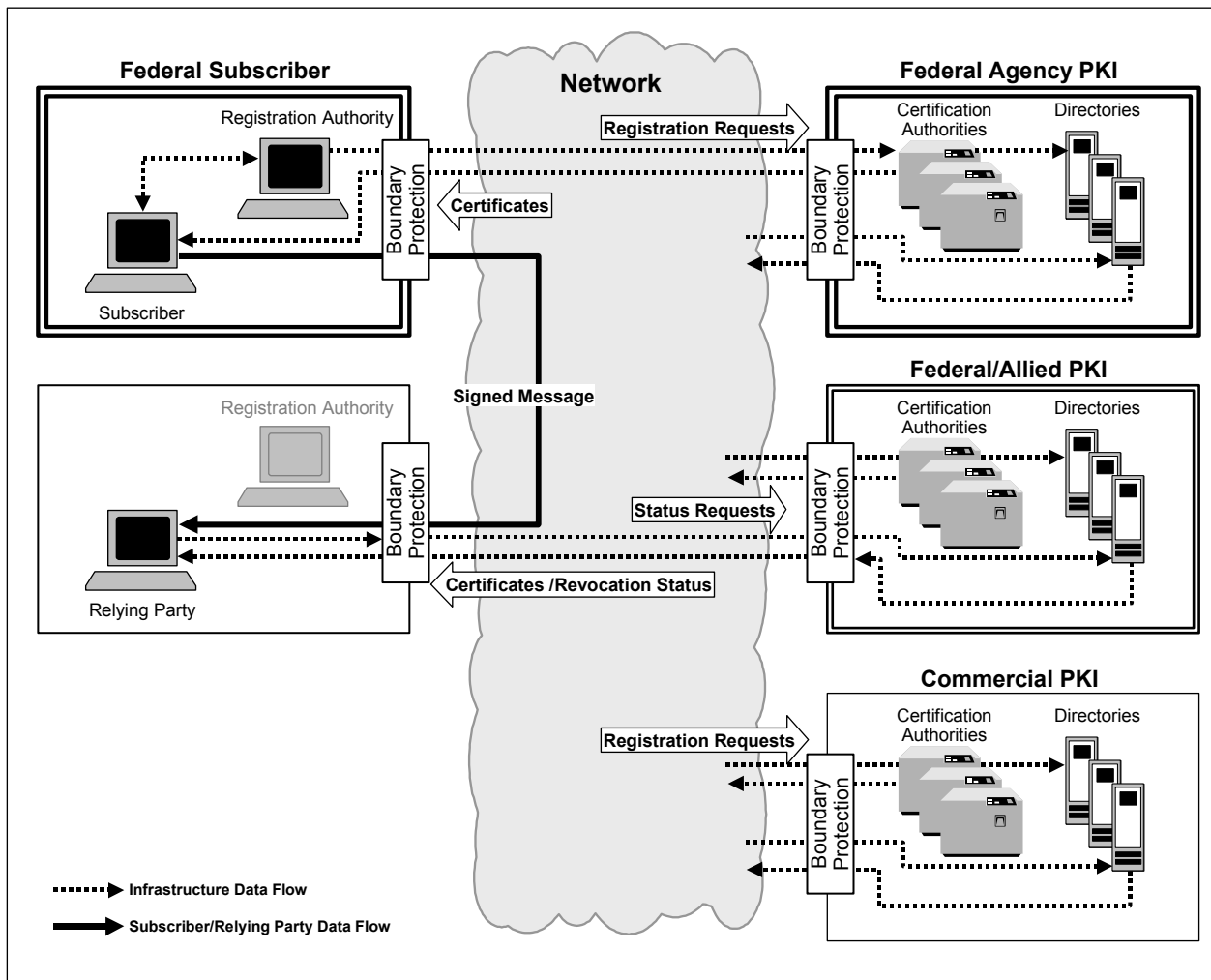

iatf\_8\_1\_2\_0041

Figure 8.1-2. Using PKIs in Secure Enclaves

Relying parties in other enclaves, associated with other PKIs, may authenticate the subscriber's public key if they trust the issuing CA. If a subscriber trusts a particular CA to correctly associate identities and public keys, then the subscriber can load that authority's public key into his or her cryptographic application. Any public key certificate whose signature can be verified

with the public key from the “trusted” CA certificate list (trust list) and is not listed on the CRL is considered valid. This means that the subscriber’s public key can be extracted from that certificate with confidence that it really belongs to the subscriber.

Many CAs are required to support the validation process. Figures 8.1-3 and 8.1-4 illustrate several approaches for relying parties to address the problem of validating their certificates issued by the numerous CAs in use.

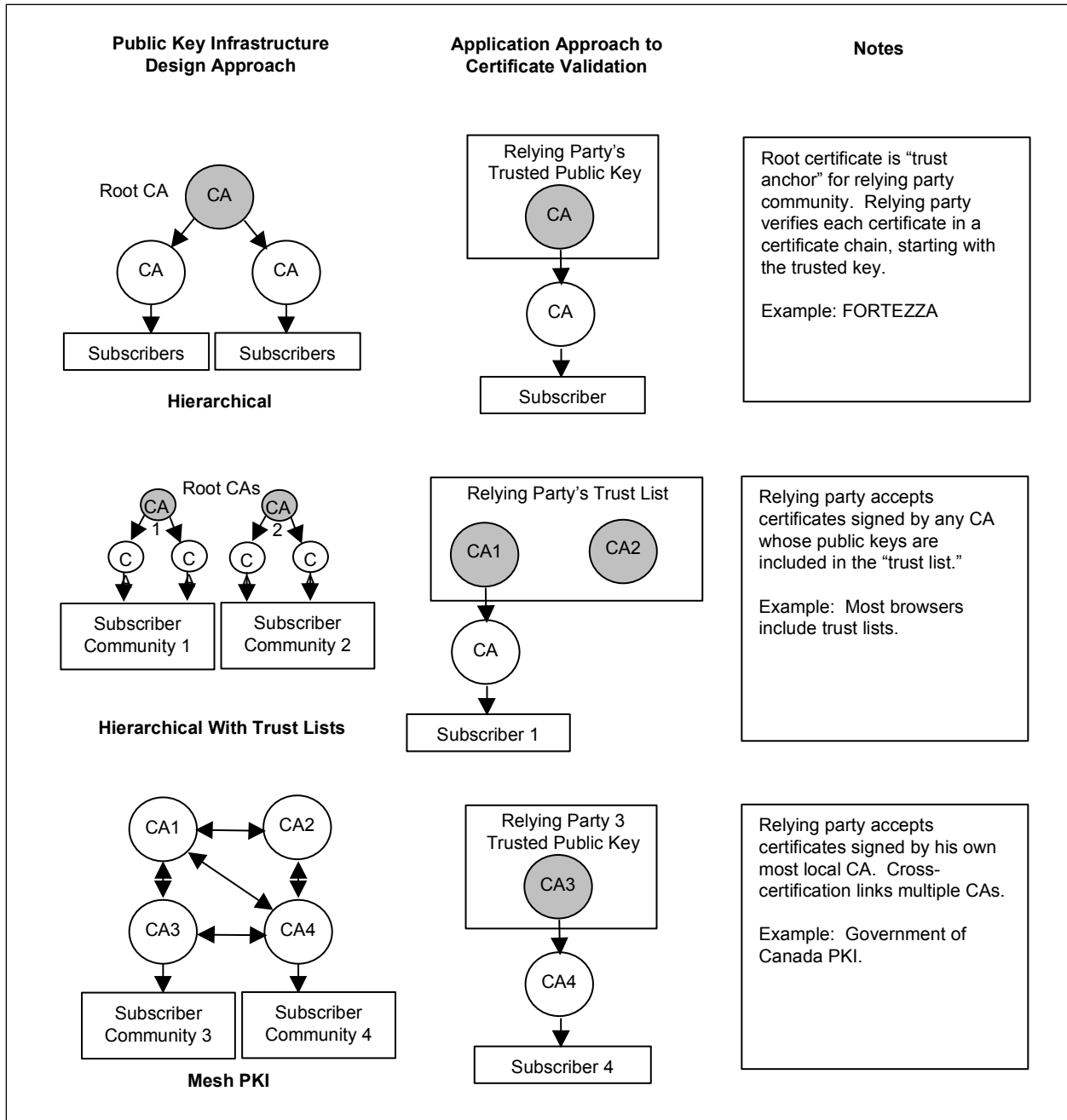

iatf\_8\_1\_3\_0042

**Figure 8.1-3. Hierarchical, Trust List, and Mesh Approaches to PKI Interoperation**

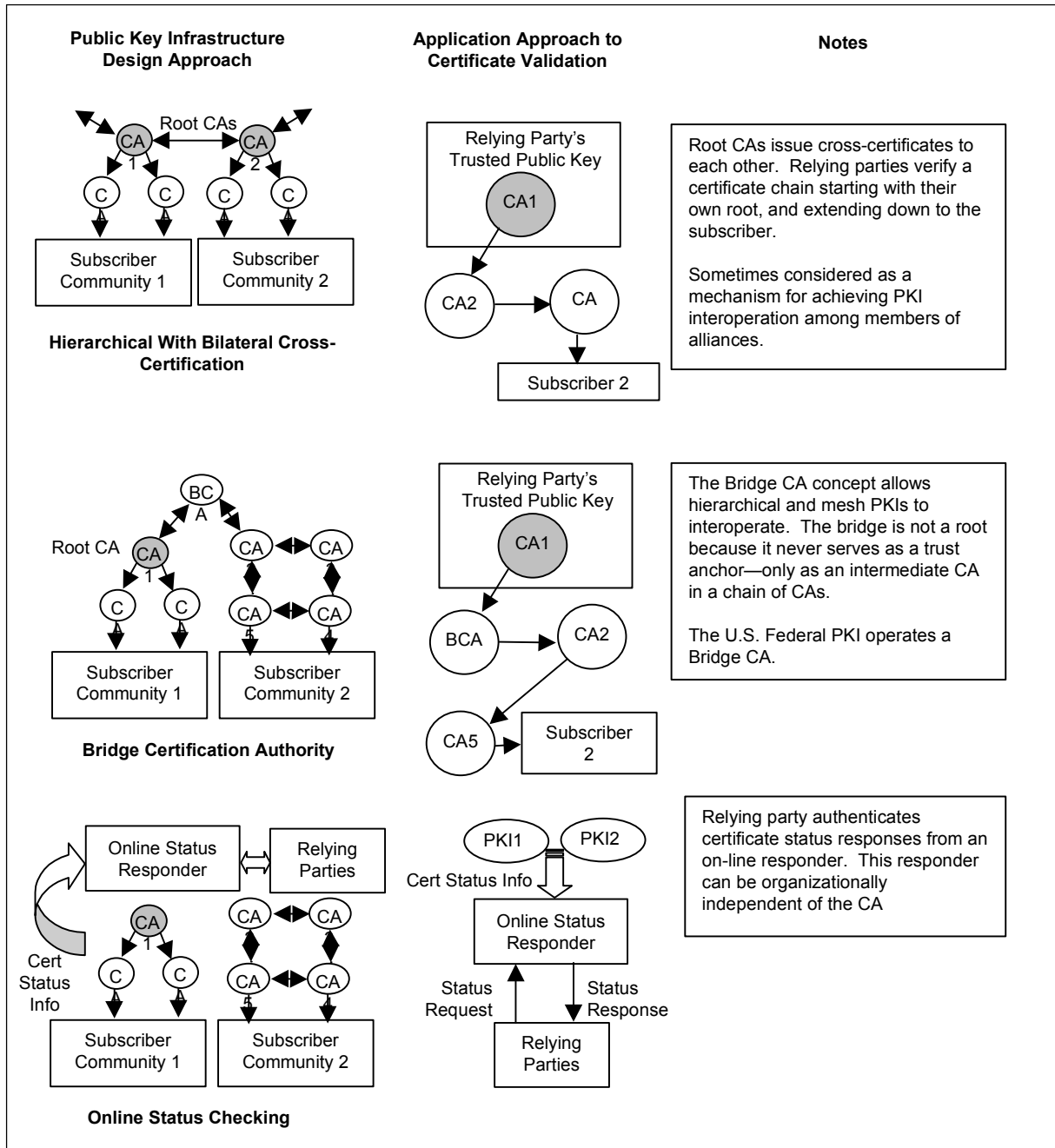

iaff\_8\_1\_4\_0043

**Figure 8.1-4. Bilateral Cross-Certification, Bridge CA, and Online Status Approaches to PKI Interoperation**

Large PKIs will often support many CAs. The CA may “certify” the public key certificates of other CAs. When CAs do this, they are stating that certificates issued by the certified CAs should be trusted. PKIs are often composed of a hierarchical arrangement of CAs, with a Root CA at the top of the hierarchy. In this way, many CAs may be certified on the basis of approval by the Root CA that serves as a “trust anchor” for the PKI relying parties.

Although hierarchical PKIs have proven very popular for hierarchical organizations, many relationships within or among organizations are not hierarchical, and hence hierarchical arrangements of CAs are not always practical. For example, relying parties in the Federal Government will sometimes wish to authenticate public keys that originated from the commercial entities, academia, and foreign partners—none of whom will tolerate a subordinate hierarchical arrangement of CAs with the Federal Government.

A common way to deal with the problem of multiple nonhierarchical PKIs is to load multiple CA certificates into the verifying applications to be used as *trust anchors*. Most commercial Web browsers already have over 50 “trusted certificates” preloaded in their trust lists by the Web browser vendors. Subscribers may add other trusted certificates to this list, or delete the ones that are already there. So long as the certificate being verified was signed by a CA whose certificate is loaded in the trust list, or has a chain of certificates that terminates in a certificate included in the trust list, then the verifier considers the signer’s certificate to be valid.

Another approach to dealing with nonhierarchical PKIs is bilateral cross-certification, which does not require a superior-inferior relationship between the CAs as is the case in hierarchical CA PKIs. Rather, two CAs—wishing to establish mutual trust among their two subscriber communities—issue certificates to each other that certify each other’s public keys. PKIs that implement such bilateral cross-certification schemes are sometimes called mesh PKIs, to distinguish them from hierarchical PKIs. Hierarchical and mesh PKI schemes can be combined. For example, it is possible for the Root CAs for two hierarchical PKIs to cross-certify on a peer basis.

A special case of the mesh PKI is the Bridge CA (BCA). A Bridge CA issues cross-certificates to Principal CAs for multiple PKIs, thus reducing the burden of bilateral cross-certification. The Federal Government is deploying a BCA, which is expected to be the primary mechanism for cross-Federal PKI (FPKI) interoperation. The Federal BCA is discussed further in Section 8.1.7.4, U.S. Federal Public Key Infrastructure.

In either hierarchical or mesh PKIs, the signature verifier must build a chain of certificates that extends from the signer’s public key to the CA that the signature verifier trusts. The verifier then must verify the signatures and check the revocation status for each certificate in the resulting chain. If each certificate in the chain is valid, then the verifier may consider the signer’s public key to be valid.

An approach to certificate validation that breaks with the entire notion of certificate chains is that of online certificate validation. Online certificate validation involves sending a certificate to a networked resource that has been programmed to accept or reject certificates based on the organization’s validation criteria.

Each approach to achieving interoperation among multiple PKIs has advantages and disadvantages, and each has aspects that must be considered carefully if security is not to be degraded as the community of interoperation is expanded. A full discussion of these factors is beyond the scope of this document, but discussed below are a few important points for each of the more common approaches to achieving cross-PKI interoperation.



### 8.1.2.1.1 Hierarchical CAs

#### Advantages:

- Many applications process hierarchical PKI certificates well.
- Relatively straightforward means for a large organization to enforce an organization certificate policy on a large community by revoking certificates from “subordinate” CAs not complying with the Certificate Policy.
- Application certificate processing is relatively straightforward.
- Only one “Root CA” certificate needs to be distributed to the applications via “out-of-band” authenticated channels to provide trust in a large number of certificates issued by subordinate CAs.
- Revocation of the subordinate CAs in the hierarchy is straightforward.
- Strong mitigation of “transitive trust” concerns exist; all trust decisions are made within the hierarchies of trusted PKIs (see disadvantages under “mesh PKIs”).
- Large subscriber community can be managed using a relatively few CA certificates, providing ease of management.
- Hierarchical PKIs are usually interoperable with applications implementing trust lists.

#### Disadvantages:

- If the Root CA certificate is compromised, the hierarchical CA’s entire subscriber population is at risk, and all subscribers must load new root certificates. Consequently, Root CA keys are normally very carefully protected.
- Hierarchical arrangements of PKIs often do not parallel organizational relationships; nonhierarchical organizations (e.g., collections of allies) often reject a hierarchical arrangement of CAs.
- PKI components based on an assumption of applications requiring only hierarchical CA elements may not be able to cross-certify, and such elements may not be able to interoperate with applications implementing mesh PKIs.

### 8.1.2.1.2 Trust Lists

#### Advantages:

- Commonly available in commercial applications.
- Relatively simple application certificate processing software.

## UNCLASSIFIED

Key Management Infrastructure/Public Key Infrastructure  
IATF Release 3.1—September 2002

- Provides a mechanism to provide a “per-CA” trust/do not trust decision for each instance of deployment of a public key using application.
- No centralized management required.
- Very flexible.
- Compatible with other mechanisms of achieving trust; use of trust lists in one PKI domain does not preclude interoperation with other PKIs using other mechanisms.
- Compatible with hierarchical PKIs.
- Strong mitigation of “transitive trust” concerns—all trust decisions are made locally, or within the hierarchies of trusted PKIs (see disadvantages under “mesh PKIs).”

### ***Disadvantages:***

- Management of the trust list often depends on local network administrators—or even individual relying parties—who often either do not understand PKI technology or do not have a basis for making informed decisions regarding which CAs should be trusted and which should not.
- Many applications are preloaded with dozens of CA certificates. Relying parties often accept all certificates issued by these CAs, without knowing anything about the level of assurance provided by the certificates these CAs issue.
- Modification of the trust list must be made relatively simple and hence may be relatively easy to subvert (technically or via faulty procedures).
- There is no straightforward revocation mechanism. If an organization wishes to stop trusting another CA, then the word must be spread to the organization’s relying party population, and each network administrator or individual must remove the revoked CA from all applications manually.
- PKI elements based on assumptions of trust lists may not be able to cross-certify, and applications that rely on cross-certification cannot interoperate with such PKI components.

Note that some applications allow authenticated distribution of centrally managed trust lists, which mitigate (in some cases, eliminate) many of these concerns.

### **8.1.2.1.3 Mesh PKIs**

#### ***Advantages:***

- Allows CA trust relationships to mirror business or other nonhierarchical trust relationships.

## UNCLASSIFIED

Key Management Infrastructure/Public Key Infrastructure  
IATF Release 3.1—September 2002

- Relieves individual subscribers and their network administrator of the burden of maintaining trust lists.
- Not susceptible to the security vulnerabilities associated with distributed management of trust lists.
- Compromise of any CA certificate affects only the subscribers of that CA; there is no “Root CA” certificate whose compromise would be catastrophic.
- Applications designed to validate mesh PKIs also can usually validate hierarchical PKIs if a cross-certification exists between the mesh and the hierarchy.

### **Disadvantages:**

- Developing and verifying chains of certificates from large mesh PKIs requires complex application software, and can have negative performance impacts.
- Because CAs are certifying other CAs, which may certify yet other CAs in other organizations, the arrangement of the mesh structure and the certificate security extensions must be very carefully managed to prevent the certificate chains from reflecting unintended trust relationships. This issue is sometimes called the “transitive trust” problem.
- Applications based on trust lists or hierarchical PKI concepts cannot interoperate with mesh PKIs without modification.

### **8.1.2.1.4 Online Certificate Validation**

#### **Advantages:**

- Is simple application software.
- Relieves relying parties of the need to manage trust lists.
- Avoids the security vulnerabilities of managing trust lists.
- Avoids the management difficulties associated with mitigating transitive trust for mesh PKIs.
- Allows very rapid dissemination of revocation data. Note that most other methods (e.g., trust lists, hierarchical and mesh PKIs) use CRLs, which applications pull from directory systems for revocation notification. These CRL-based revocation notification methods can be as rapid as online checking, depending on the frequency of CRL updates and the details of the directory implementation. Online status checking can be seen simply as use of a special protocol for accessing a centralized trust/revocation list. The speed of revocation for such online methods depends on how often the centralized trust list/revocation list is updated, rather than on the speed of the online validation transaction. Conversely, for large PKIs with distributed directory systems, CRL

distribution and hence revocation notification can be slowed as a result of directory replication schemes.

- Allows applications to be compatible with all other PKI concepts because the online responder can implement virtually any certificate verification technology.

### **Disadvantages:**

- Requires reliable network connections between the online validation responder(s) and all relying parties; relying parties not able to access the responder cannot process certificates.
- Believed by some analysts that the centralized nature of online responders creates scalability problems, though such responders can be “mirrored” or replicated (perhaps at the cost of introducing the performance delays associated with directory replication).

Note that regardless of the approach to how PKIs provide for cross-domain interoperability, relying parties can establish trust only in certificates they can obtain. Many application protocols provide some or all of the signature certificates and CA certificates necessary to verify subscriber signatures, but for public key applications that encrypt data, the relying party must obtain the subscriber’s encryption certificate before encrypting the data. This transfer of the encryption certificate (sometimes called a key management certificate or confidentiality certificate) can be accomplished via an “introductory” message between the subscriber and the relying party, or the relying party can obtain the certificate from a certificate repository—often a directory system. See Section 8.1.4, Infrastructure Directory Services.

## **8.1.2.2 Security Services**

The PKI plays a pivotal role in the generation, distribution, and management of the keys and certificates needed to support the public key-based security services of authentication, integrity, nonrepudiation, and confidentiality. The PKI itself employs some of the security services of confidentiality and integrity. Encryption is applied to private key material that is generated, stored, and distributed by the PKI to keep the private keys confidential. Integrity services are provided to the public key material that is certified by the PKI. The digital signature on a public key certificate binds a subscriber’s identity with the public key, ensuring that the integrity of the public key contained within the certificate is maintained.

## **8.1.2.3 Infrastructure Processes**

A variety of processes or functions are associated with the operation of a PKI that will be described in this section. This section is organized to reflect the KMI/PKI process categories that were described in Section 8.1.1.3, Infrastructure Process, and summarized in Table 8.1-3. Not all of the KMI/PKI process categories apply to certificate management; processes that do not apply will be indicated.

## UNCLASSIFIED

Key Management Infrastructure/Public Key Infrastructure  
IATF Release 3.1—September 2002

The type of applications that PKI is supporting affects certain PKI processes. This section describes the processes in the context of two public-key based applications: secure Web and secure messaging. These applications were selected because of their pervasive nature and because they illustrate the differences between real-time (secure Web) and store-and-forward (secure messaging) applications. Within this section, the differences in PKI processes that result from the influence of these different applications will be indicated. Key and certificate management for Web browsers and servers is described to show the PKI support required to enable secure Web communication via the Secure Sockets Layer (SSL) protocol. Key and certificate management associated with e-mail clients is described to show the PKI support required to enable secure messaging via secure messaging protocols such as Secure/Multipurpose Internet Mail Extension (S/MIME).

After reading this section, one will note that the majority of certificate management processes are transparent to subscribers of the PKI. Subscribers only need to know the name of the CA and either its e-mail address or Universal Resource Locator (URL) to communicate with it. Subscriber action is required in order to generate key material and obtain certificates used within secure applications such as web and messaging. However, this interaction is part of the security configuration for a secure product and is usually accompanied by an instructive subscriber interface.

### 8.1.2.3.1 Certificate Policy Creation

A Certificate Policy states the following:

- The community that is to use a set of certificates.
- The applicability of those certificates (that is, the purposes for which the certificates are appropriate).
- The common security rules that provide relying parties with a level of assurance appropriate to the community and their applications.

Before a PKI issues certificates, it should define its Certificate Policy and provide mechanisms to ensure that policy is being enforced by the PKI elements. In fact, one can consider a PKI to be nothing more than an organization's approach to generating and managing certificates in accordance with its certificate policy. This topic is discussed further in Section 8.1.5.1, Policy Creation and Management.

### 8.1.2.3.2 Registration

The registration function is defined in Section 8.1.1.3, Infrastructure Process, as the "authorization of people to make decisions about the validity of the subscriber actions." In general, the person responsible for decision making in the PKI context is a Certificate Management Authority (CMA). CMAs may be CAs (if they sign certificates or if they are responsible for a facility that automatically signs certificates) or an RA, if they simply provide the CA or CA facility with registration information. In any case, the CMA is responsible for

reviewing certificate requests and verifying the information contained within the requests before generating certificates. The CMA operator is also responsible for authenticating the identity of the certificate requester to ensure that the proper identity is bound to the public key contained in the certificate.

When an organization establishes a PKI, it will identify the personnel who will be the CA and RA operators. The qualifications (e.g., clearances, training) for the personnel who assume these roles are often outlined in the PKI's Certificate Policy (or sometimes in a Certification Practices Statement [CPS]). The CA and RA operators must also be registered with the CA or RA software being used within the system. These operators normally have special accounts that will gain them access to the administrative functions performed by the CA or RA component. To access these accounts, the operators will need to authenticate themselves to the CA or RA components. Forms of authentication include the use of passwords, public key certificates, or hardware tokens and will depend on the capabilities of the CA or RA components used within the PKI.

Although most security products in use today require subscriber intervention in the key generation and certificate request process, other models need to be considered. One model is the case in which an organization requests a set of certificates on behalf of its subscribers. In this case, the organizational representative who submits the list of subscribers requiring certificates to the PKI may need to be registered with the PKI before submitting the list. Registration will assure the PKI operators that the organizational request is submitted from an authorized source. Many CA products available today have or are adding preauthorization features that will allow them to support this organizational registration model. Subscriber intervention is still required in the actual certificate request and response process to ensure that the proper key material and certificates are installed at the subscriber workstation.

### **8.1.2.3.3 Ordering**

The primary function associated with ordering in a PKI is the request for a certificate. Certain PKIs may also generate key material for a subscriber. In these PKIs, the request for a certificate will also result in the generation of a public/private key pair. Discussions of key generation by the PKI will be described in subsequent releases of the Framework in Section 8.1.2.3, Infrastructure Processes. The remainder of this discussion assumes that the subscriber generates the public/private key pair and is indicative of the majority of secure applications in use today.

The certificate request process for Web browsers is described in detail. Differences between this process and the certificate request processes for Web servers and for S/MIME electronic mail clients will then be described briefly.

## **Web Browser**

Figure 8.1-5 shows the first set of steps involved in obtaining a client certificate that is installed in a Web browser. The focus of these steps is on key generation and certificate request generation. The subscriber begins the key generation and certificate request process by directing

the Web browser to connect with the CA Web front-end. The subscriber then fills in the certificate request HyperText Markup Language (HTML) form that is presented by the Web front-end. After completing the form, the subscriber presses the submit button on the form. An HTML tag (KeyGen) that appears on the form triggers the browser to generate a key pair for the subscriber. If this is the first time a subscriber has generated key material using the browser, the subscriber will be prompted to provide a pass-phrase. This passphrase is used to encrypt the subscriber's key material when it is stored in the key database that is located either on a floppy diskette or on the subscriber's workstation. When the subscriber needs to use the key material, the subscriber will be required to supply the pass-phrase, so that the material may be decrypted.

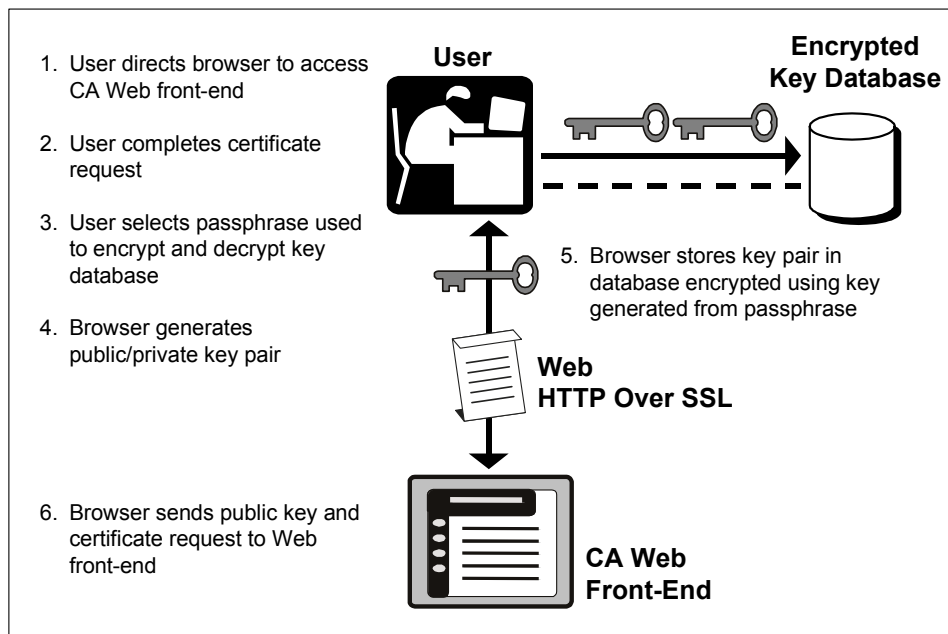

iatf\_8\_1\_5\_0044

**Figure 8.1-5. Browser Certification: Key Generation and Certificate Request**

After the key material is generated, the browser provides the certificate request, which includes the public key and the information from the completed HTML form, to the server via a HyperText Transfer Protocol (HTTP) "PUT." Most Web browsers available today support either the Public Key Cryptography Standard (PKCS) 10 [2] or Netscape proprietary certificate request format. Both formats are self-signed, which means that the private key corresponding to the public key contained within the request is used to digitally sign the request. The CA verifies the digital signature on the request before generating the certificate. This verification ensures that a private key associated with public key being certified exists and that the certificate request had not been modified in transit. Obviously, the self-signed certificate request can be spoofed. If the certificate request is captured in transit, the public key and corresponding certificate can be replaced. To counter such a threat, CAs usually only accept certificate requests across a secure channel such as an SSL-encrypted session between the browser and the CA Web front-end.

The CA stores the certificate request until the RA or CA operator approves it. Some CAs provide a reference number to the subscriber, which the subscriber can use to make inquiries regarding the status of the certificate request or to download the completed certificate.

Figure 8.1-6 shows the steps conducted by the CA to process the certificate request received from the subscriber. The certificate request approval and certificate generation process—depicted in Figure 8.1-6 and described below—assumes that the CA provides a RA function. Noted that the architectures of CA products vary. Not all CAs have a RA component, nor can they be configured to provide such a function. If there were no RA function available, then the CA operator would conduct all steps within the certification process.

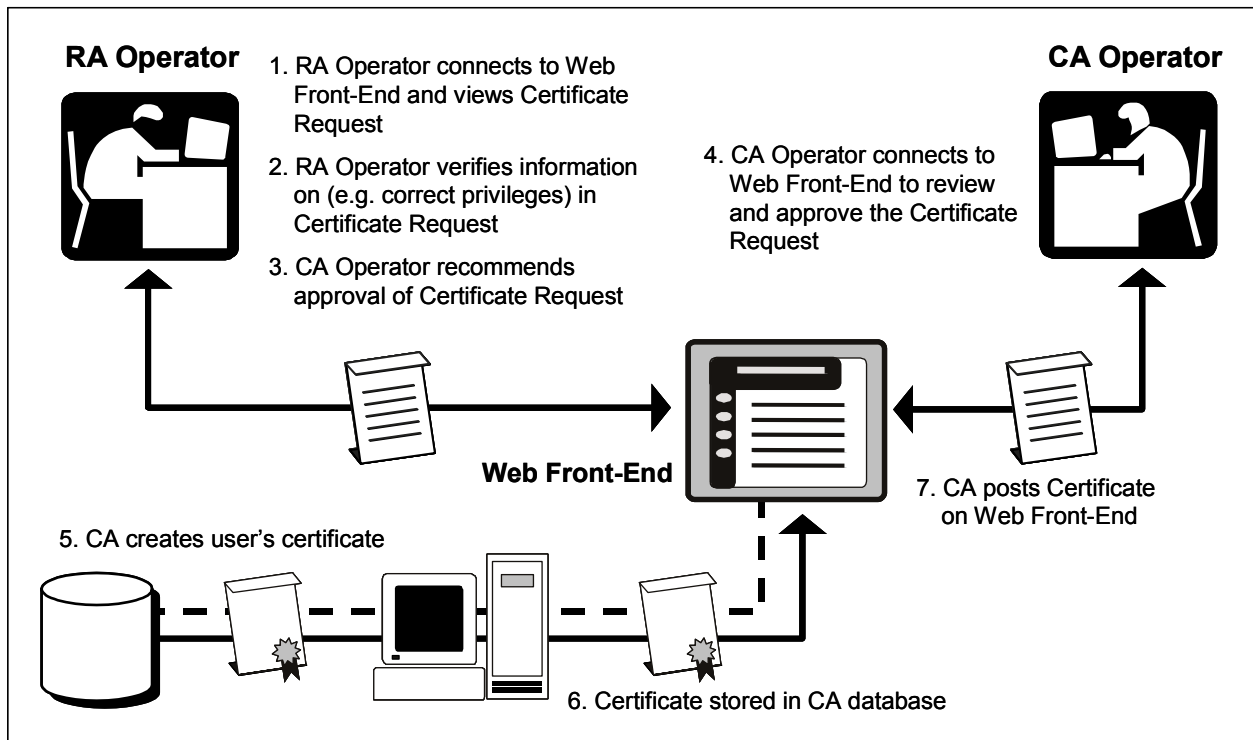

iatf\_8.1\_6\_0045

**Figure 8.1-6. Browser Certification: CA Processing Request**

The RA accesses the Web front-end to review any pending certificate requests. The RA displays the information contained in the request and verifies that it meets the policies set by the CA (e.g., if the subscriber's Distinguished Name [DN] follows the proper format or if the subscriber's key is of a certain length). If further information is required before the request can be processed, the RA can contact the subscriber who submitted the request. Other procedural activities, such as requiring the subscriber to be authenticated in person by the RA, may also be implemented at this point.



## Web Server

The procedure for generating a certificate for a secure Web server is similar to generating a subscriber certificate for installation into a Web browser. Most secure servers provide a forms-based interface for the Web server administrator. One of the options available through the form is to generate and install server certificates. The administrator performs the following steps for generating and installing the Web server's certificate.

The first step is to run the key generation program at either the command line or via a graphical user interface (GUI). The steps for generating the public and private key pair are similar to generating a subscriber's public and private key file. The administrator must specify a file name to which the new key pair file will be stored. The administrator may need to generate random information to initialize the random number generator. Finally, the administrator must supply a passphrase that will be used to protect the key pair. After the administrator has created the server's key pair file, the administrator fills out the server's certificate request. The certificate request contains information including the server's DN and the administrator's e-mail address and telephone number. Web servers use the PKCS 10 certificate format. After the form is completed, the administrator can send the form to the CA. E-mail is the transport mechanism presently used by Web servers to submit certificate requests and receive certificates.

The CA process for a server certificate request is essentially the same as that of the Web browser. The only difference is the request is received at the CA via e-mail and the certificate is returned to the server via e-mail. In-person authentication of the Web server is also not feasible. The CA operator can confirm information about the server request with the system administrator by requiring that the administrator appear in-person at the CA or requiring that documentation be provided by the server's owning organization, which states that the server is located at that organization and requires a certificate.

## S/MIME Client Certification Process

Figure 8.1-7 shows the certification process for a generic S/MIME client. Using the security configuration options of the S/MIME client, a key pair for the subscriber is generated locally. The private key is stored in the key's database of the product. This database is protected by a key computed from hash of a pass-phrase provided by the subscriber at key generation. The public key is placed either in a self-signed certificate or in a certificate request. This description focuses on the latter option, which requires interaction with PKI components. S/MIME clients support the PKCS 10 certificate requests, which are transported to the CA via e-mail (Simple Mail Transfer Protocol [SMTP]) using a *smime.p10* message format.

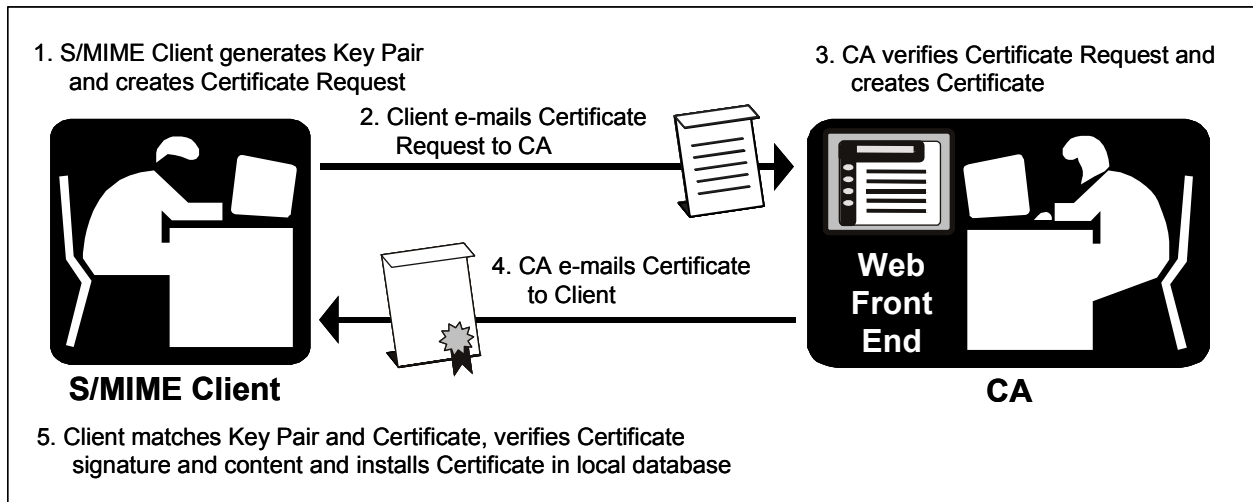

iatf\_8\_1\_7\_0046

**Figure 8.1-7. S/MIME Client Certification Process**

The certificate request is received at the CA via e-mail. Once the request is received, the actual generation process for the S/MIME client certificate is essentially the same as that which was followed for the Web browsers and servers previously described. In-person authentication of the subscriber may be implemented by the CA if so desired.

### 8.1.2.3.4 Generation

In the context of PKIs, there are two aspects of generation: key generation and certificate generation. Both generation aspects are described in this section.

#### Key Generation

In public key management, the generation of key material is closely tied with the request for a certificate. Therefore, Section 8.1.2.3.4 is written following a distributed model where the key material is generated locally in the context of the secure application. It is also possible to generate public key material following a centralized model where the CA or some other trusted entity would generate the key material on behalf of the subscriber or application. Because keys are generated in a single place and using only one system, centralized key generation offers the opportunity to use better equipment (e.g., cryptographic hardware, random number generators, and techniques within the key generation process). Centralized key generation is often used in environments with very strong security requirements. In addition to the location of the key generation, the models also differ in the type of additional key management functions that are required to support each model. When the key material is generated locally, the private key stays within the control of the subscriber or application from its generation to its destruction. Only the public key needs to be conveyed to the CA for inclusion in the certificate that the CA will subsequently distribute to the subscriber or application. When the key material is generated centrally, not only does the CA have to generate and distribute the certificate, but also there is the added function of securely distributing the private key to the subscriber or application.

## UNCLASSIFIED

Key Management Infrastructure/Public Key Infrastructure  
IATF Release 3.1—September 2002

Today, secure private key distribution is achieved through manual distribution or distribution via a secure protocol, which may be proprietary, specific to a product line, or a more widely accepted security protocol such as SSL.

Another consideration when generating key material centrally is how the key material is to be used. Usually only asymmetric key material that will be used for key or data encryption is generated centrally. Key material, which will be used for digital signature purposes, is normally generated locally. This is the preferred approach because one would like to use digital signatures to provide the security services of nonrepudiation. True nonrepudiation services can be provided only if the entity generating the signature key material is the only one who knows the private key. If the digital signature key material were generated centrally, then this would not be the case. In light of these considerations, asymmetric cryptographic products are now migrating to two key systems in which separate key material is used for data/key encryption and digital signature purposes. Commercial products are available that combine both the distributed and centralized key generation methods. These products generate key material associated with key or data encryption centrally and key material associated with digital signature locally.

Another topic associated with key generation is whether the key material is generated in software or in hardware. Many of the commercial security products available today perform all cryptographic functions, including key generation in software. However, concerns exist that software cryptography may not be adequate for all situations. Therefore, there has been a move to provide flexibility within security products to allow key material to be generated and cryptographic functions to be performed on hardware tokens, including both personal computer (PC) cards (a.k.a., Personal Computer Memory Card International Association [PCMCIA] Cards) and International Standards Organization (ISO) 7816 compliant smart cards. Note that many of the commercial CA products available today use hardware tokens or other types of cryptographic hardware to generate the CA key material and perform the cryptographic functions associated with the CA functions. When hardware tokens are used, there are added management functions associated with the tokens themselves, including their initialization, personalization for a particular subscriber, and distribution of the token and any personal identification number (PIN) associated with the token. Today, many of the token management functions are handled outside the context of the PKI. The FORTEZZA Certificate Management Infrastructure (CMI) is one notable exception. However, there appears to be a trend within the PKI arena to add token management functions to the growing list of functions provided by the PKI.

Another consideration associated with key generation is the length of the key material. In general, the longer the key length the stronger the key because it is more difficult to break longer keys. In the commercial cryptographic implementations in use today, asymmetric key materials are usually 1,024 bits long, with 2,048 bit or longer keys being used for more sensitive applications such as CA signing keys. Today, strong symmetric key implementations use 128 bit keys. Type 1 cryptographic implementations used to protect classified information use even longer keys. Note that export and import controls imposed by governments may restrict the key lengths within exportable or importable versions of cryptographic-based products.

## Certificate Generation

As was done in the Ordering section, a full description of the Web browser certificate generation process is provided. Differences between this process and that of the Web browser and the S/MIME e-mail client are summarized.

### Web Browser

Figure 8.1-8 shows the steps conducted by the CA to process the certificate request received from the subscriber. If all the information within the request is satisfactory and the subscriber is authenticated to the RA's satisfaction, the RA marks the certificate for approval. Depending on the configuration of the CA product, the certificate may be automatically generated once the RA has approved the request or CA operator intervention may be required to generate the certificate.

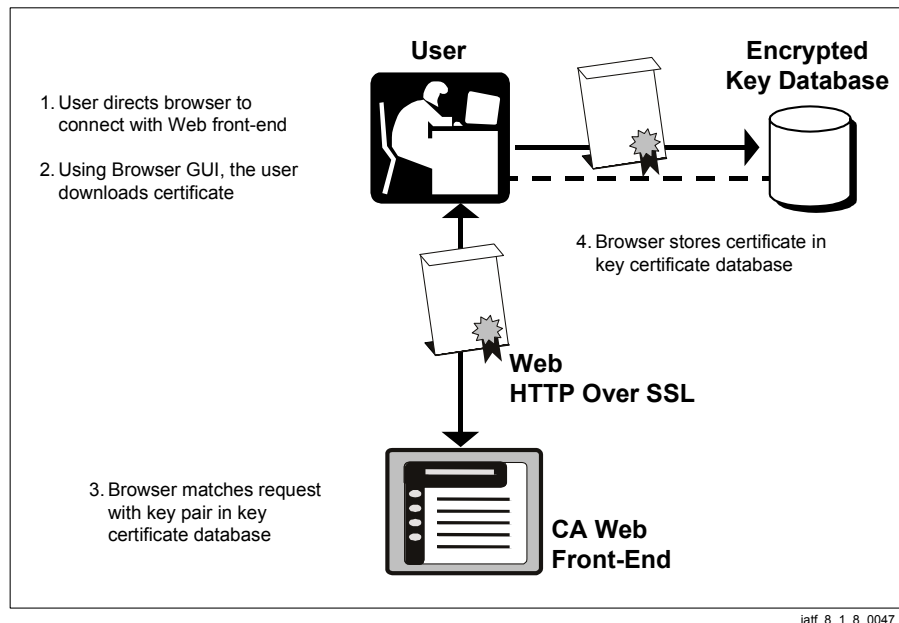

**Figure 8.1-8. Browser Certification: Installing Certificate in Browser**

Once the certificate has been created, a copy of the signed subscriber certificate is stored in the CA database and posted to the Web front-end. The subscriber can then download and subsequently use the certificate. Many CA products send e-mail to the subscriber to notify them that the certificate has been created and to provide them the URL where they may download the certificate. If the CA does not provide notification services, then the subscriber would need to periodically check the Web front-end to determine if the certificate is ready.

### Web Server

The CA process for generating a server certificate is about the same as that of the Web browser. The only difference is that the certificate is returned to the server via e-mail.

## S/MIME Client

The certification process for a S/MIME client was shown in Figure 8.1-7. The certificate generation process for the S/MIME client certificate is about the same as that which was followed for the Web browsers previously described. Once the certificate request is validated, the CA generates a certificate for the S/MIME subscriber. S/MIME clients expect to receive certificates back, in PKCS 7 [3] format via e-mail.

### 8.1.2.3.5 Distribution

Certificates can be distributed in several ways. The certificates can be e-mailed to the requesters, or the requester can download a copy of the certificate from the Web front-end of the CA or from a certificate repository such as a directory. This section describes the distribution options for certificates in the context of secure Web and messaging applications. As was done in the Ordering and Generation sections, a full description of the Web browser certificate generation process is provided. The difference between this process and that of the Web browser and the S/MIME e-mail client are summarized.

#### Web Browser

Once the certificate has been posted to the Web front-end, the subscriber can then download and subsequently use the certificate. Many CA products send e-mail to the subscribers to notify them that the certificate has been created and to provide them the URL where they may download the certificate. If the CA does not provide notification services, then the subscriber would need to periodically check the Web front-end to determine if the certificate is ready. Figure 8.1-8 shows the final set of steps that complete the certification process.

To download the certificate, the subscriber needs to direct the browser to connect to the Web front-end. The subscriber may supply a reference number supplied during the certificate request process to find their certificate that appears as a hotlink. The subscriber clicks on this link to start the download process. Following the set of subscriber screens that the browser displays, the subscriber accepts the certificate for download. The certificate is downloaded and stored in the keys database where it may subsequently be referenced. As part of the download process, the browser software checks that the private key associated with the public key contained in the certificate is located in the key database. If the associated key is not found in the database, the software will not download the certificate and will provide an error message to the subscriber.

At certificate retrieval time, the subscriber may also need to download certificates associated with the CAs within its certification path. Usually the CA certificates are also available for download via a Web interface. The download of the CA certificate is about the same as that of a subscriber certificate. The browser stores the CA certificate within its certificate database. However, the browser does differentiate between subscriber and CA certificates and considers the CA certificates to be trusted, meaning that certificate path validation will terminate once a CA certificate in the path is not found in the certificate database. The browser is able to identify CA certificates from subscriber certificates, because different HTML tags are applied to each

type of certificates. Note that Web browsers are distributed with a number of well known root CA certificates (a trust list) already installed in the certificate database. These certificates are usually associated with vendors that provide certification services. It is possible to modify the certificate database and delete any CA certificates that one does not want to be trusted within a specific environment.

## Web Server

Web server certificates are distributed to the server via an e-mail message from the CA. Certificates are often sent in a PKCS 7 [3] SignedData formatted message. This message format allows the full certification path (server and CA certificates) associated with the subscriber to be conveyed in the same message. Once the administrator receives the certificate from the CA, the administrator can install the certificate into the server. Most servers provide a GUI for this step. The GUI typically asks for the pathname to the file containing the certificate, or the certificate can be pasted into a text block on an HTML form. The Web server will then automatically install the certificate in the Web server's encrypted key database. As part of the download process, the server software checks that the private key associated with the public key contained in the certificate is located in the key database. If the associated key is not found in the database, the software will not download the certificate and will provide an error message to the administrator. Any CA certificates found in the PKCS 7 message will be installed within the certificate database of the Web server. Like Web browsers, the CA certificates are considered trusted and are indicated as such in the certificate database of the Web server.

## S/MIME Client

An S/MIME client receives the certificate back from the CA in an e-mail message. Like Web servers, S/MIME certificates are sent in a PKCS 7 [3] SignedData formatted message. Once received at the client, the message is opened by the subscriber. The S/MIME client provides functionality that verifies the PKCS 7 formatted message and automatically installs the client certificate and any CA certificates in the local certificate database. As with both the Web browser and server, the S/MIME client also differentiates CA certificates from subscriber certificates within its database and is normally distributed with popular root CA certificates installed. However, unlike the Web products, most S/MIME products do not automatically trust CA certificates installed in the client. Normally, the subscriber will need to explicitly mark the certificate as trusted before the client will recognize the certificate as trusted.

### 8.1.2.3.6 Compromise Recovery

This section describes how the PKI notifies its subscribers when certificates are revoked and assists its subscribers in recovering from a compromise of key material. Recovery of the PKI itself from a compromise will be described in Section 8.1.5.8, Compromise Recovery.

There will be instances when the certificates issued by a CA need to be revoked. Revocations fall into two major categories: security compromise revocation and routine revocation. Security compromise revocation covers instances when the associated private key material has been

## UNCLASSIFIED

Key Management Infrastructure/Public Key Infrastructure  
IATF Release 3.1—September 2002

compromised, when a subscriber no longer can gain access to the private key (e.g., forgotten PIN or password or lost token), or if the subscriber has been fired or stripped of privileges granted by an organization. Report of such compromise should be immediate, and the actual revocation of the certificate by the CA should occur immediately. Routine revocation covers cases in which certificates need to be revoked because information contained within the certificate is no longer valid for a variety of reasons (e.g., name changes [marriage/divorce]) or a change of organizational affiliation. These types of revocations also need to be reported to the CA.

Regardless of the reason, for compromise it is important that the CA be notified about the need for revocation. Thus, a certificate revocation notice is sent to the CA that issued the certificate. This certificate revocation notice may take many forms, including an e-mail message, a phone call to the CA operator, the submission of some other type of form, or some combination of the above. It is important that the CA operator ensure that the revocation notice is authentic before revoking a certificate to prevent denial of service attacks. The request may be authenticated in various ways, including the use of a digitally signed revocation notice, the provision of a password, or in-person authentication. Commercially available CA products are only beginning to add automated certificate revocation notification to their products; therefore, the variety of authentication options is likely to grow.

A CA notifies other subscribers when a certificate has been revoked through the issuance of CRLs. A CRL contains certificates still within their validity interval, but that no longer represent a valid binding between a public key and a DN or privilege. Certificates must remain on the CRL until their expiration date. The CA will periodically generate and distribute CRLs. CRL distribution mechanisms are usually the same as those employed for certificates; CRLs are posted to directories, made available via a Web interface or distributed via e-mail.

The distribution and process associated with a CRL is one of the major issues faced within the PKI community today. There is a concern about the timeliness of revocation notification because CRLs may only be generated periodically. To counter this issue, emergency CRLs or CRLs containing only certificates revoked because of compromise may be distributed on a more frequent basis and may be pushed to the subscribers versus just posted to a repository where the subscriber may need to go to retrieve the CRL. Another major concern is that the CRLs may grow rather large, especially as the number of certificates issued by a specific CA increases. The size of a CRL will affect the time it takes to validate a certificate path. Finally, there is often no consolidated directory from which applications can obtain CRLs. Because of these problems, many of the security products available today do not provide an ability to process CRLs, or the subscribers must resort to manual methods to remove a revoked certificate from the databases of these products. At the same time, there is ongoing research exploring alternative certificate revocation models.

One such alternative is the online validation of a certificate. In this case, a certificate or certificate path may be sent to a trusted entity—which may be a CA or a certificate repository—which will determine if the certificate(s) is valid and notify the requester of the results. Online validation also brings its own set of concerns. Online validation requires that there be network connectivity between the requestor and the trusted entity performing the validation. The availability of the network and the added network traffic resulting from the

validation requests and responses are considerations associated with implementing online validation. The level of trust needed in the entity performing the validation is also an issue and will depend on the requirements of the environment in which one is operating.

A CA also assists subscribers in their recovery from a key compromise. In the case where the CA has been involved with the generation of the key material or the initialization of a token, the CA may offer backup functionality. In this case, if the subscriber has lost access to the key material and needs to recover information that may have been encrypted in that key material, the CA may be able to provide a copy of the key to the subscriber or issue a new token with the old key material provided. In the case of a security compromise, the subscriber will need to have a new key pair and certificate generated. The CA will be involved in this process to the extent it was involved in the initial key and certificate generation process that was described earlier in this section.

### **8.1.2.3.7 Accounting**

A number of auditing functions associated with the PKI are described in Section 8.1.5.7, Accounting.

### **8.1.2.3.8 Key Recovery**

A PKI may provide key recovery functionality by providing key backup or escrow of key material. Key backup or escrow capabilities are normally provided only to asymmetric key material that is used to encrypt either data or keys and not to key material used for digital signature purposes. Key backup or escrow capabilities can be provided when the CA generates the keys on behalf of the subscriber. In this instance, the CA will store a copy of the private key in a secure database. This key material may be retrieved from the database and used to recover information encrypted with the material if the need arises. It is possible for a CA to provide backup capabilities even when the subscriber generates the key, but this raises the issue of how the private key is securely sent to the CA for backup. It is also possible that a completely separate infrastructure other than the PKI can be used to support key recovery.

### **8.1.2.3.9 Rekey**

During the course of PKI operations, it will become necessary to renew certificates. There are two cases for renewal: one is when the certificate reaches its natural expiration date, whereas another is when the previous certificate has been revoked and a new certificate needs to be issued. For the first type of renewal, there are two subcategories: a renewal where both a new key pair and certificate are generated, or a renewal where the key material is not changed but a new certificate is created. Whether a new key pair is generated is dependent upon the recommended key life span. If the key life span and certificate validity period coincide, then new key material should be generated at renewal. However, if the key life span is longer than the certificate validity period, then it may be possible to recertify the key material, until its recommended life span is reached.



Certificate renewal with rekey is about the same as the generation of an initial certificate, whereas the renewal without rekey may be a somewhat simpler process. CA products today vary in their renew capabilities and may limit the amount of information within the certificate that can be changed at renewal time.

### **8.1.2.3.10 Destruction**

Unlike symmetric key management, the PKI is not normally involved in tracking the destruction of key material. When asymmetric key material reaches its expiration date or when it has been compromised, it may be destroyed. The subscriber would normally do the actual destruction of the material. At this time, most security products require that a subscriber manually remove old keys and certificates from the database. Note that there are instances when a subscriber would need to retain key material even after its expiration or compromise in order to be able to recover data encrypted in this key material. In this instance, the subscriber (or an agent acting on behalf of the subscriber) will need to retain the material until access to the encrypted data is no longer needed or when the encrypted data has been re-encrypted in new key material.

### **8.1.2.3.11 Administration**

Administration functions for the PKI are described in Section 8.1.5.12, Administration.

## **8.1.2.4 Requirements**

Overall security requirements for PKIs are specified in a Certificate Policy, which describes requirements imposed both on the operation of the PKI and on PKI subscribers. General requirements for a KMI/PKI that are common to many Certificate Policies are found in Section 8.1.1.4, Requirements. PKI subscriber requirements commonly found in Certificate Policies are described in this section. Requirements specific to the operation and maintenance of the PKI itself are described in Section 8.1.5, Infrastructure Management. Requirements related to the use of PKI services include the following:

- Subscriber generated asymmetric key material shall be generated securely.
- The subscriber shall protect the private key material from disclosure and shall also protect any password or PIN used to access the private key material.
- A subscriber shall provide accurate information to the CA when requesting a certificate. In other words, the subscriber shall provide the appropriate identifying information and the appropriate public key for certification.
- The subscriber shall only use the private key and associated public key certificate for applications or purposes approved by the PKI. Approved applications are normally documented in the CPS for the PKI.
- The subscriber shall notify the CA when the private key has been compromised, or if other information within the certificate becomes invalid.

- The subscriber shall obtain the public key of the Root CA and any CA public key certificates from an authorized source in a secure manner.
- If an organization requests certificates on behalf of a group of subscribers, the organization's representative shall provide the CA with an accurate list of subscribers to whom certificates shall be issued.

## 8.1.2.5 Attacks and Countermeasures

The strength of the security services provided by a cryptographic capability such as digital signature depends on a variety of factors, including the security of the underlying cryptographic keys, the strength of the binding between the subscriber identity and public key, and the specific application implementation. As a result of the PKI's role in the generation, distribution, and maintenance of private and public keys and certificates, threats to the PKI are of concern. If the PKI operates as expected, the confidentiality of private keys and the integrity of public keys should be maintained. However, it is possible that threats to the PKI—be they intentional or unintentional—may result in the disclosure of the private keys or in the modification of the public keys. Other threats to the PKI can lead to the denial of services provided by the system. This section focuses on the attacks and countermeasures specific to the PKI. These attacks and countermeasures are discussed from the perspective of the subscribers of a PKI. Infrastructure specific attacks and countermeasures are described in Section 8.1.5, Infrastructure Management. More general attacks and countermeasures for KMI/PKI can be found in Section 8.1.1.5, Attacks and Countermeasures.

### 8.1.2.5.1 Attacks

Attacks aimed at the PKI subscriber are designed to gain access to the subscriber key material, to modify or substitute the subscriber key material, or to deny the services of the PKI to the subscriber. Attacks include the following:

- **Sabotage.** The subscriber's workstation or hardware token on which key materials and certificates are stored may be subjected to a number of sabotage attacks, including vandalism, theft, hardware modification, and insertion of malicious code. Most of these attacks are designed to cause denial of service. However, attacks such as hardware modification and insertion of malicious code may be used to obtain copies of subscriber key material as they are generated or to obtain information entered by the subscriber such as a password.
- **Communications Disruption/Modification.** Communications between the subscribers and the PKI components could be disrupted by an attacker. This disruption could cause denial of service, but also could be used by the attacker to mount additional attacks such as the impersonation of a subscriber or the insertion of bogus information into the system.
- **Design and Implementation Flaws.** Flaws in the software or hardware on which the subscriber depends to generate and/or store key material and certificates can result in the malfunction of the software or hardware. These malfunctions may deny services to the

## UNCLASSIFIED

Key Management Infrastructure/Public Key Infrastructure  
IATF Release 3.1—September 2002

subscriber. The flaws may be accidentally or intentionally exploited to disclose or modify the subscriber's key material or certificates. Improper installation of the software or hardware may also result in similar consequences.

- **Subscriber Error.** Improper use of the software or hardware associated with the subscriber's interaction with the PKI or with the storage of keys and certificate generated by the PKI may also result in denial of service, or the disclosure or modification of subscriber key material and certificates.
- **Subscriber Impersonation.** It is possible that an attacker may impersonate a legitimate subscriber of the PKI. Depending on whether the PKI generates key material on behalf of a subscriber, the attacker may obtain both key materials and certificates in the name of the legitimate subscriber, or the attacker may substitute his or her own key material for that of the legitimate subscriber and obtain a certificate from the PKI.

### 8.1.2.5.2 Countermeasures

Countermeasures that can prevent or limit the attacks to subscribers of a PKI include the following:

- **Physical Protection.** Physical protection of the subscriber's workstation, communications link with the CA, and/or hardware tokens will counter many of the sabotage and communications disruption related attacks.
- **Good Design Practices.** Concerns over flaws in the software and/or hardware design may be alleviated if good design practices are followed during the development of the software and/or hardware used in conjunction with the PKI.
- **Testing.** Testing of the software and/or hardware may also be used to counter attacks to the system that result from the exploitation of flaws in the system.
- **Training.** Training of subscribers is vital to eliminating or at least reducing the possibility of inadvertent attacks due to subscriber error.
- **Strong Authentication.** Strong authentication of the subscriber by the PKI components greatly reduces the possibility of impersonation attacks.
- **Encryption.** Encryption of the link between the subscriber and the PKI components reduces the possibility that an attacker may eavesdrop on the communications and try to disrupt or modify the communications.
- **Contingency Planning/System Backup.** Backup of a subscriber's key materials, certificates, and relevant software and hardware is the best mechanism for protecting against design flaws that result in system failure.

A Certificate Policy describes all countermeasures a PKI requires to provide a level of assurance consistent with anticipated certificate usage.

## 8.1.3 Symmetric Key Management

### 8.1.3.1 Overview

Although overshadowed by PKI in the literature, Symmetric Key Management (SKM) remains an important technique in the real world.

Most legacy systems use symmetric cryptography exclusively. Even with the expanding use of asymmetric techniques, many new and emerging applications, such as multicast, will still require secure symmetric key and asymmetric cryptography.

With a symmetric key algorithm, the encryption key can be calculated from the decryption key and vice versa. This is very different from the public key algorithm where it is presumed unfeasible to calculate the decryption key from the encryption key. In most of the symmetric systems, the encryption and decryption keys are the same, requiring the sender and the receiver to agree on a key before they can pass encrypted messages back and forth. Information on certificate based public-key algorithms can be found in Section 8.1.2, Certificate Management.

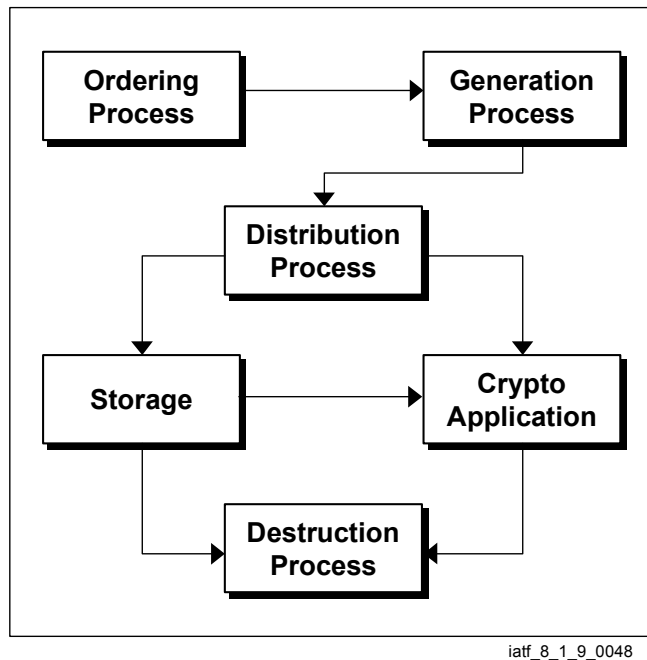

**Figure 8.1-9. Critical Elements of Symmetric Key Management Activities**

The old adage “good management is the key to success” could never be more true than in the application of symmetric key in the world of cryptography. The strongest of cryptographic algorithms are reduced to nil if the management of the keys used with the cryptography is poor. For symmetric key applications where a common secret key is required by all users, delivering the correct key to all the users and keeping them secret can be extremely complicated and expensive. Figure 8.1-9 depicts the critical elements of symmetric key management.

System requirements play heavily in the decision to use symmetrical key because there are significant advantages and disadvantages in its use. Many of the problems with SKM have become more complex as the community of cryptographic users has increased and become more geographically separated. Ordering, generation, distribution, loading key into cryptographic applications, storage, and key destruction are becoming more critical.

### 8.1.3.2 Advantages of Symmetric Key Technology

- Everyone in a communications network can use a single key for as long as necessary. The keys can be changed as often or as infrequently as the security policy allows.
- Local generation of keys can minimize many of the problems with ordering and distribution. There is no need to connect with a central authority.
- Key structures for symmetric key are extremely simple—predominately, a sequence of random numbers.
- Algorithms using symmetric key processing are usually much faster than their asymmetric counterparts. In many instances, asymmetric keys are used to securely distribute the symmetric keys to other users in the network.
- Symmetric keying supports netted and point-to-point operations.
- Symmetric keying limits who holds a specific key; therefore, no outside access control mechanisms are needed to control who talks to whom.
- Symmetric keys do not require extensive validation before use.
- Symmetric keys are not reliant on an extended trust path.
- Potentially fewer people need to be trusted in the ordering and distribution path.
- The creation of an unauthorized key is only dangerous when an attacker can get someone to use it in place of the correct key; consequently, alone it does no harm.

### 8.1.3.3 Problems with Symmetric Key

- One lost key will compromise the whole network, requiring the replacement of every user key.
- Limited cryptographic services (e.g., no nonrepudiation, implied authentication).
- There is difficulty scaling to large communities. There is an upper limit for the size of cryptographic networks using a common key.
- The larger the number of operators using a common symmetric key, the more likely the key will be compromised.
- Large amounts of symmetric key may need to be produced to meet potential compromise and contingency uses. This key must be securely delivered and locally stored.
- Distribution delay causes key to be generated and distributed well in advance of its use; allowing potential harmful access to the key for longer periods of time.
- Nets must be predetermined. It is difficult to create dynamic communication networks.

- Key must be kept secret at all times.
- Long cryptoperiods cannot be used for per-session communications.
- There is no intrinsic way to know who created the key.
- There is no back traffic protection. A compromise of a key at any time exposes all traffic encrypted using the key since the beginning of the cryptoperiod.

### 8.1.3.4 Critical Elements of Symmetric Key Management

Good key management with its many facets is vital for maintaining security. SKM involves the total life expectancy of a key; controlled processes should be established and maintained for ordering, generation, distribution, storage, accounting, and destruction of the key. There must be ways to detect compromised keys and provisions to resecure the system and efficiently determine the extent of any compromise.

- **Ordering.** Only authorized individuals should be allowed to order key and only keys for which they have been given explicit authorization to order. Because the symmetric networks must be predefined, the orderer must have access to the communication network management. They need to know what users will need the key and when they will need it. The key must be ordered so that it can be delivered to all users prior to them needing it. When the key is generated centrally, it may require ordering several months in advance of actual use, given the worldwide nature of many nets. The key management system must ensure that the orderer has the authorization to order the key as well as whether the recipient(s) are authorized to receive the key.
- **Generation.** Generation must be performed in a secure environment to prevent unauthorized access to the key. The best cryptographic algorithms can be nullified if the key falls into the wrong hands. The generation process must be able to produce the total set of acceptable keys for the specified encryption algorithm. Weak or sensitive keys associated with the specified algorithm must be deleted (e.g., DES has 16 weak keys). [4] Symmetric keys are usually random bit streams requiring a quality control process to ensure the randomness of the bit streams.
- **Distribution.** Symmetric key can be delivered in physical form depending on trusted people and technical protection techniques like tamper-resistant canisters. For very sensitive key, two-person control can be used to gain more assurance. These techniques, however, provide only minimal protection to the key over its life cycle. The more people having access to a key, the more likely it is to be compromised; therefore, a goal of secure distribution is to provide the key electronically directly from the generator to the user equipment through benign delivery techniques. Public key techniques can support benign delivery techniques. They allow the user equipment to create an authenticated session key with the generator to pass symmetric key. When true benign techniques are not possible (i.e., the user equipment does not have asymmetric cryptography), the key

## UNCLASSIFIED

should be protected in encrypted channels as long as possible. Electronic deliveries to an intermediate node close to the user may be a reasonable compromise.

- **Storage.** Keys must be stored when waiting for distribution to the user or when used as contingency key. Storage of unencrypted symmetric keys may be required to recover when a link goes down. The protection of these keys is critical. They must be stored securely. Physically distributed key can be protected only through strict physical and personnel security. Electronic keys should be stored in encrypted form where physical, personnel, and computer security mechanisms are in place to limit who can decrypt and access the keys.
- **Loading Key Into the Cryptographic Application.** Loading key requires a protected interface. Physical protection of the key at the interface is critical to prevent the key from being exposed where it could be copied or replaced. Although minimal protection is required for loading encrypted keys, a high level of protection is required for the less frequent loading of the corresponding protection decrypt key.
- **Destruction.** Many potential media exist with which symmetric key can be deployed. These media include paper (e.g., manual codebooks, key tape), mechanical components (e.g., plugs, boards), and electronic components (e.g., random access memory [RAM], electrically erasable programmable read only memory [EEPROM], programmable read only memory [PROM]). Because the compromise characteristics of symmetric key allow recovery of previously encrypted traffic, it is imperative that the keys not be stored any longer than necessary to perform their mission. At the end of a cryptoperiod, the secret key must be destroyed in all locations (including secondary sources like contingency storage and incidental electronic storage).
- **Compromise.** Symmetric keys are vulnerable to compromise (e.g., physical delivery, large cryptonets, long cryptoperiods), so compromise detection and recovery are critical. There are no technical mechanisms where the network can control the damage done through a compromise. The compromise of a secret key potentially exposes all the traffic it ever encrypted and invalidates the assumed authentication for future traffic. To recover from a compromise, each user must be notified and provided a new key. The major problems of this approach stem from the long time it might take to notify the users and then the length of time necessary to replace the keys. While users are being notified and taken off the net, other users may still be using the key thinking that it still protects the data. There are no technical mechanisms that can be used to ensure that all users have been notified. There is a significant denial of service issue bringing up a widely dispersed network. Even after a user has stopped encrypting on the compromised key, the user cannot communicate until the new key arrives, either from contingency stock or the generation of new key.
- **Accounting.** As a result of the distribution of keys to a large number of users potentially scattered around the world and the corresponding danger of a compromised key, additional mechanisms must be in place to track keys throughout their life cycle. Effective accounting improves the tracking of who had authorized access to a key, when and where key was delivered, and when a key was destroyed.

### 8.1.3.5 Some Good Practices With Symmetrical Key

- A key order must always validate the initial requirement for the key, the number of copies, the time when the key is needed, and the intended recipients.
- Revalidate requirements each time new keys are generated.
- Ensure that the person ordering and the person receiving the key are authorized for the key.
- Do not create and distribute the key too early (i.e., keep the storage time short). There must be enough lead time to ensure that all recipients have gotten their key.
- All key must be securely generated. This includes checks on the created key to ensure randomness.
- Secure local generation may be the best method.
- Key should be securely distributed using benign techniques where available. Where benign techniques cannot be used, limit the number of people having authorized access to the key. Use physical distribution only where absolutely necessary.
- Limit the size of the cryptonet to reduce the number of people who have access to the key.
- Limit the cryptoperiod of the key to limit the damage of an unidentified compromise.
- Limit the amount and duration of contingency key created to reduce the potential for compromise during the storage period.
- Develop procedures to quickly notify all users of a compromised key and how to replace the key with a new one.
- Train users not to use compromised key while waiting for their replacement key.
- Develop effective accounting to track the status of all keys throughout their life cycle.
- Periodically validate all key-handling procedures.
- All procedures and policies must be rigorously enforced.

## 8.1.4 Infrastructure Directory Services

### 8.1.4.1 Overview

Infrastructure directory services—through a structured naming service—provide the ability to locate and manage resources within a distributed environment. The directory also provides



access control over all the objects represented within this distributed information service. Directory design can be categorized by objects within (scope of content) and functionality (range of services) supported. Within the context of this document, Directory services (see Figure 8.1-10) support provisioning of symmetric and asymmetric key material, as well as the management data for confidentiality, integrity, and identification and authentication across the enterprise.

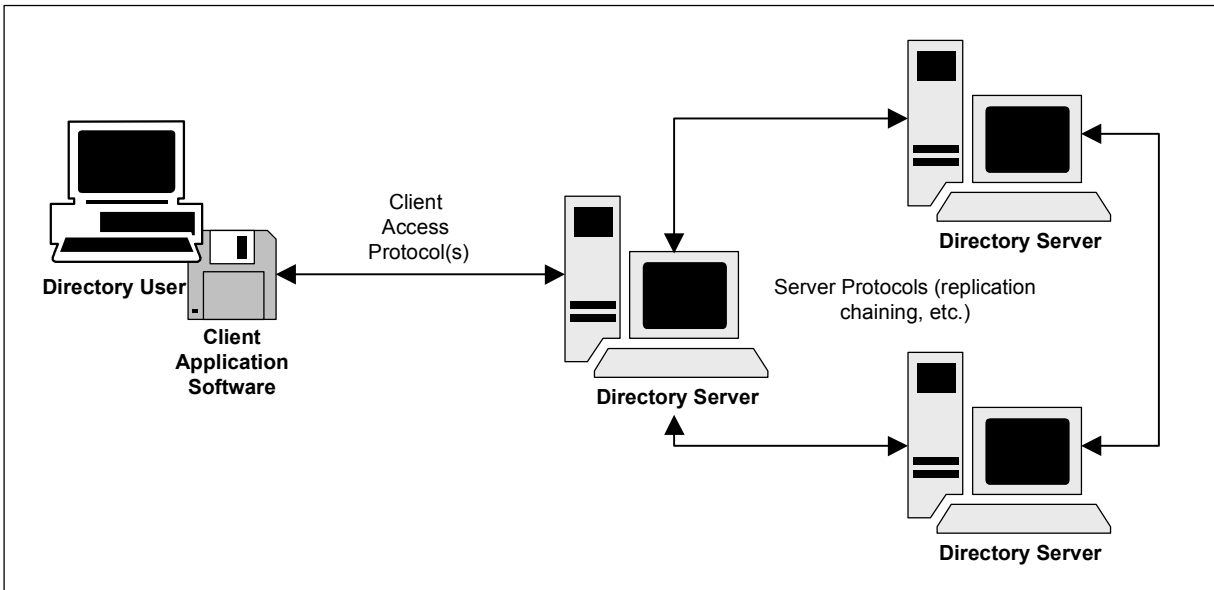

iatf\_8\_1\_10\_0049

**Figure 8.1-10. Directory Model**

Infrastructure directory services provide a means to associate multiple elements of information with respect to a specific person or component. This association is managed in a hierarchical organization and indexed by name association. The most common example is a telephone system “white pages” that supports the association of name resolution with address and phone number elements. In the evolving distributed network environment, much more information needs to be managed, requiring more than general-purpose directory functionality. Today, a majority of deployed directory systems are considered “application-specific,” such as PKI, white pages, e-mail, or Network Operating Systems (NOS) directories.

### 8.1.4.2 Characteristics of Infrastructure Directory Services

Infrastructure directory services have several key characteristics. These characteristics are defined as follows:

- **Defined Name Space.** Directory services typically invoke a hierarchical namespace logically structured in an inverse tree. This naming format can be used to consolidate the accesses, easing user location of information. X.500 distinguished names, Request for Comment (RFC) 822 e-mail naming, and DNS domain names may be used.

- **Highly Distributed.** Directory services reliably distribute the data to multiple servers, whether they are located across an enterprise or within a LAN environment. The mechanisms to allow partitioning of information, its access constraints, and timely access are provided. Additionally, the ability to replicate data across the Directory services makes the system more resistant to failure and maintains accessibility.
- **Optimized Data Retrieval.** Directory services enable the user to search on individual attributes of an object. The design supports a significantly higher ratio of “reads” to “write” operations. Most directory products assume 99 percent of the operations accessing the Directory Information Base (DIB) will be lookups and searches, as opposed to relatively few changes or additions and deletions.

Infrastructure directory services are expected to provide access to any application. Those core applications that will access directories are X.500 Directory Access Protocol (DAP); LDAP; e-mail (S/MIME V3), and a Web-based access (https). Future enhancements will include support for dialup accesses, in support of wireless key management.

The types of clients that access directory services are as follows:

- **Interrogation Clients**—performing general queries for user information.
- **Modification Clients**—performing queries and being cryptographically enabled to perform strongly authenticated binds and modification operations on selected user attributes.
- **Administrative Clients**—who have all the features of the modification client and are permitted to manage user entries and operational information.

### 8.1.4.3 Information Model

The information model describes the logical structure of the DIB from the perspective of both the directory users and the administrators (see Figure 8.1-11). The information model defines the relationships between the objects, attributes, and associated syntax in a “schema.” The user information portion contains the information about a directory object that is viewable by the majority of the accesses to the DIB. The

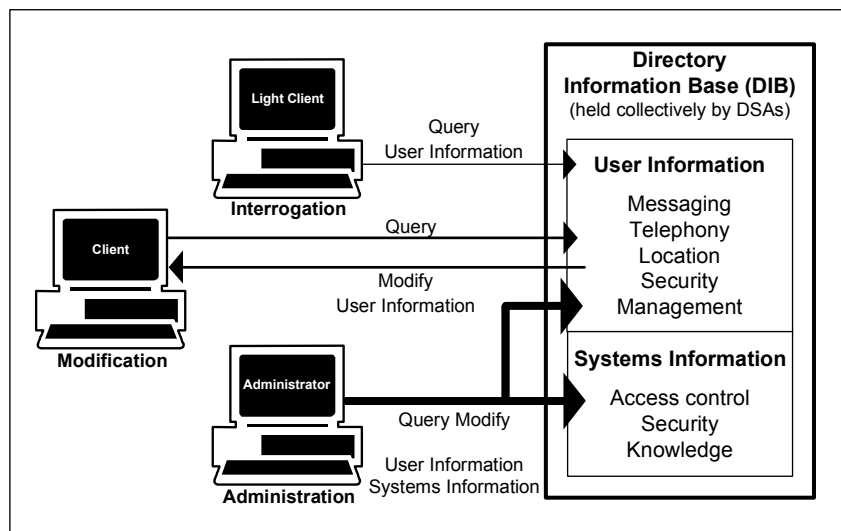

Figure 8.1-11. Directory Use Access

operational and administrative information portion of the DIB contains those elements of information used to track directory operations. These attributes are typically schema information, access control information, and information related to replicating data. Operational and administrative information is not returned in response to normal directory queries.

Further discussions related to directory distribution and Directory System Agents (DSA) information models will be included in future releases of this document.

## 8.1.4.4 Directory Information Tree

The directory system schema is the set of rules that define how the Directory Information Tree (DIT) is constructed, defines the specific types of information held in the DIB, and defines the syntax used to access the information. A schema has three components:

- **Classes**—the set of objects within.
- **Attributes of each object class**—the set of properties allowed by that class of object.
- **Attribute syntax**—which delineates the syntactic form and any matching rules used with that attribute.

In X.500-based directory systems, an object identifier (referred to as an “oid”) references object classes and attributes. In many LDAP systems, the data is essentially a string of characters, with no equivalent object identifier. This is problematic in those environments where compilers are used to interpret the data and apply cryptographic services to that data. The use of Abstract Syntax Notation number One (ASN.1) and associated Distinguished Encoding Rules (DER) is critical to ensuring security mechanisms applied to data in one component or domain will remain intact when used in another component or domain.

These three elements follow a set of rules to ensure appropriate placement of the objects into the DIT. Content rules identify mandatory and optional attributes within a given object class. One problem associated with the use of the X.509 CA object class is that it requires a *userCertificate* attribute. Thus, when the entry for the CA is created, either the CA must have the privilege to create the entry and post a certificate at the same time, or the operation will fail, violating the content rule. Many environments use directory administrators to create entries (add an object class) and allow other entities (like the CA) to populate (add) attributes at some future time. The newer LDAP V2 schema defines a *pkiCA* object class, where the certificate information is optional. Thus, a directory administrator can add the object class, and the CAs can subsequently add the attributes with valid data.

Schema extensibility is a very useful feature to incorporate into a directory system. As new elements of data are defined, they should be added to a directory without requiring the directory to be restarted or the compiler reconfigured. More products are providing this feature; however, if a new object is added to the directory, consideration should be given to the upgrade of the clients that may need to retrieve and use this new element.

A DN is a sequence of naming attributes that uniquely identify an object that may be represented by an entry in the directory. Objects that may be identified using a distinguished name include organizational units, people, roles, address lists, devices, and application entities. A DN is used as the primary “key” to locate an entry in the directory system. The DN is also typically used to identify the subject or issuer of an X.509 public key certificate.

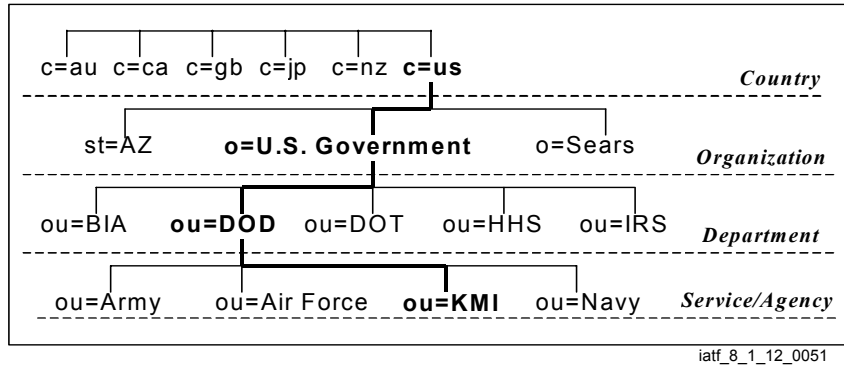

**Figure 8.1-12. Key Management Infrastructure Directory Information Tree**

The naming attributes that form a DN are organized in a hierarchy reflecting the DIT with a name lower in the tree identified relative to its parent entry by adding Relative Distinguished Name (RDN) attributes to the parent’s DN (see Figure 8.1-12). Note that naming conventions and registration processes must be clearly articulated for a domain.

Before an entry is created

for an object in the directory (or a certificate created for that object), it must be allocated a DN that is unique across the enterprise. An RA normally performs the creation of a distinguished name in the directory system. Disambiguation of names is critical for key management functions; however, it is usually approached with an emotional perspective rather than a logical view. Recommendations for namespace management will appear in later versions of this Framework.

## 8.1.4.5 Security Model

The security model defines the access control framework and identifies mechanisms for the access control scheme applied to a DIT segment. A comprehensive security model not only addresses user access to the information within the DIB, but also includes access controls on the application itself. In addition, the security model should include the management of the cryptographic keys for identification and authentication (I&A) and, if appropriate, confidentiality for the directory servers. The confidentiality services in an infrastructure directory system are typically applied at the network or transport layer.

The security services defined below are considered against the three general threats of unauthorized disclosure, unauthorized modification, and unavailability of information contained in a directory system. The information is vulnerable when held within a DSA or when transiting elements of the directory. The security services are as follows:

- Authentication.
- Access Control.
- Confidentiality.
- Integrity.

## Authentication

Peer entity authentication is performed between the clients and DSAs and among DSAs to provide corroboration that a user or entity in a certain instance of communication is the one claimed. The authentication mechanism can be a name and password, or an exchange of cryptographically bound credentials, referred to as strong authentication. Strong authentication relies on the use of asymmetric encryption. Asymmetric encryption uses the combination of a public component and a private component to sign digitally the credentials of the user or entity authenticating itself to the system. A digital signature guarantees the origin and integrity of the information that is digitally signed. This binding of the public key and its holder's identification information is conveyed through an X.509 public key certificate that is generated by a CA. The generation of these identity certificates is usually within the bounds of an organization's certificate policy. Within a CPS, procedures should be used to create, maintain, and revoke credentials for the clients, managers, and directory servers themselves.

It is sound practice for all DSAs to be able to process bind requests that are name and password based, as well as strongly authenticated, using an agreed on digital signature algorithm. DSAs should support an access control policy that prevents the unauthorized disclosure or modification of information based on the authentication level used. The DSA should strongly authenticate itself to its communication peer (i.e., DSAs, clients, and management entities) as required by policy. The success or failure of the steps in the authentication process should be audited and stored in the DSA audit database to facilitate compromise recovery and to enhance security of the directory.

Additionally, the DSAs should not permit access to any information until all access control checks have been performed and granted. DSAs should support a standards-based (Internet Engineering Task Force [IETF], RFC 2459) signature validation process. This process should include validating the CA that produced the certificate used to sign the I&A information (i.e., validate the certification path). If the path validation process cannot be completed, DSAs should reject the request and generate an audit notice. Additionally, the DSA may lock out the user from any subsequent accesses.

Once the communications partners have successfully authenticated themselves to each other, the DSA should be capable of limiting access to information stored within its DSA according to the parent (host) system security policy. The DSA should constrain setting access and privileges to authorized management entities only.

## Access Control

Access control is based on a relatively simple concept: either a list of users and the permissions to which they are entitled, or a list of protected items and the permissions necessary to access them, is held within the directory. This information is contained within access control information (ACI) items. ACI items can be held within a number of parts of the directory depending on their intended usage and sphere of influence.

The Access Control Decision Function (ACDF) specifies how ACI items should be processed to determine whether access should be granted for a particular operation. Figure 8.1-13 is based on the ISO/IEC 10181-3 Security Framework in Open Systems standard (Part 3—access controls). The ACDF decides whether to grant or deny access to the requested object(s) by applying predefined access control policy rules to an access request.

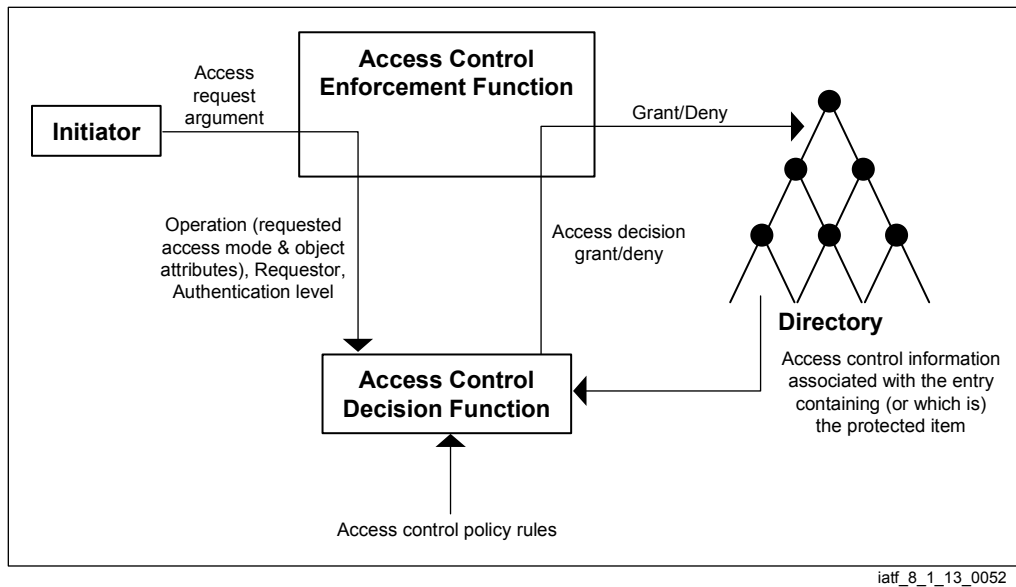

**Figure 8.1-13. Access Control Decision Function Required for Access Control**

In some situations, the directory may not give sufficient assurance that data is kept confidential in storage, regardless of access controls. Confidentiality of attributes in storage may be provided through use of an encrypted attribute. Variations are defined in ITU-T X.501 (1997) and in emerging IETF standards. In all instances, the directory servers do not support the encryption and decryption of this information.

## Confidentiality

Confidentiality at the application layer is an extremely difficult service to provide. It is defined in the 1997 X.500 Series of Recommendations, but relies heavily on the General Upper Layer Security (GULS) and the use of the Open Systems Interconnection (OSI) Presentation Layer. At this point, there are no directory server products that support this service. Emerging standards permit the use of the Transport Layer Security (TLS) with LDAP, yet again, there are few, if any, products that support this service. Network and transport layer security is an extremely useful part of the layered security approach for a directory service.

## Integrity

If integrity is required on information stored in the directory, the information should be signed. The user who requires validation of the integrity of that information should validate the signature to ensure no unauthorized modifications have occurred. If an attribute requires integrity, the syntactical definition should expressly define it as a signed object. In the public key schema context, certificates and CRLs are signed objects.

The ability to support signed operations on all operation requests received and to generate signed responses to those arguments, needs to be evaluated against a performance, risk analysis and policy basis. In many cases, it is less complex and equally secure to invoke a secure channel at the network or transport layer in conjunction with the initial binding operation. Part of the security management requires the integrity protection to be negotiated and agreed-on when establishing connectivity.

Any of the information stored within a Security Management Information Base (SMIB) should be protected against manipulation or destruction by unauthorized users or end entities. Changing any of the thresholds associated with collection of audit information should be made available to only authorized audit management entities. When information from one domain is replicated into another domain, the agreement to shadow should contain details on how archive of and access to audit data will be supported. Further details with respect to this critical security feature will be provided in later versions of this document.

### 8.1.4.6 Credential Management

Directory servers will require their own identity credentials when they digitally sign bind operations or other operations that may require integrity. Strong authentication is not widely deployed, but when it is, the volume of signature verifications requires either a “bank” of card readers, with duplicate hardware tokens in each reader, or some form of hardware accelerator deployed on the server hosting the directory service.

Directory Administrators (DA) will use their own sets of credentials when logging into the directory server. This permits auditing and tracking of those actions taken by the DA when modifying any of the operational information. DSAs will use their own credentials when responding to strongly authenticated bind requests, and when initiating strong binds between DSAs. In the few cases in which cryptographic services are enabled in directory systems, the credentials are usually uploaded to the DSAs through a floppy interface or via a PCMCIA bus interface. The initial keying and subsequent rekeying of hardware accelerators will be discussed in future versions of this document.

### 8.1.4.7 Implementation Considerations

The directory service must have realistic performance characteristics. Performance can be measured in a number of ways: ease of use, robustness, timeliness of service restoration, and speed of access response. These aspects of the system and the generation of domain specific

concepts of operations (CONOPS), policies, and procurement procedures will be discussed in later versions of this document.

- Ease of use is a factor of the system design and the tools presented to the directory user such as click and point, icons, windows, scripts, and status messages.
- Robustness deals with product and system reliability and integrity. Again, these will have to be specified in terms of integrated logistics support (ILS) and life-cycle costing (LCC) needs and in terms of mean time between failure (MTBF) or mean time to repair (MTTR) type specifications.
- The availability goal is to provide availability of any directory service 24 hours a day, 7 days a week. In the certificate management context, revocation information must be available on demand.
- Service restoration deals with the recovery time for a single DSA to attain an operational state after switching on or switching the clients (and other attached DSAs) to an alternate DSA. This should not exceed 5 minutes if the DSA is in a strategic environment. In a tactical environment, it should be less than 1 minute.
- For defining the speed of response requirements, the directory system can be seen to provide two types of access characteristics: the human access requirements, which deal with information retrieval (such as white pages information) via a man-machine interface, or specific system functions, which need to resolve, for example, names to addresses for message routing. This interface is considered to be a machine-to-machine interface. Both of the above have performance requirements. However, how these are characterized and presented can be quite different. Underlying the performance of such a large-scale system is naturally the individual DSA performance and the links used between them to other DSAs and the accessing clients.

### 8.1.4.8 Client Caching Guidelines

Employing client caching is a matter of domain policy. However, the guidelines below may be followed, especially for clients caching certificate-related information.

- Store cached information in nonvolatile memory.
- Treat cached entries and cached certificates separately for the purpose of determining the useful life of the cached information. Extend the useful cache period for the certificate, because it is a relatively static entity with its own expiration time and revocation procedures.
- Capture and record, with the cached entry, the date and time that an entry was last obtained in order to determine the expiration time of that entry.



- Upon receipt of a CRL, all components containing cached certificates compare the cached certificates against the list of revoked certificates and purge those cached certificates matching the certificates listed in the CRL.
- Purge a cached certificate upon the expiration date.

## 8.1.5 Infrastructure Management

The KMI/PKI infrastructure has many of the same characteristics and issues as the certificate management and symmetric key generation subscriber services described in Sections 8.1.2, Certificate Management, and 8.1.3, Symmetric Key Management. However, it is also a much more attractive target because a successful attack potentially subverts the security of a large number of subscribers instead of only one. In addition, it has a number of additional requirements and responsibilities not associated with subscriber services, which introduce potential new vulnerabilities. Because of these increased security concerns, the design of a KMI/PKI needs to address a wider range of issues than just supplying keys or certificates to subscribers. Although the technological solutions for these problems are substantially the same as those described in Sections 8.1.2, Certificate Management, and 8.1.3, Symmetric Key Management, their implementation, layering, and procedural security solutions will be more robust. The basis of managing a secure infrastructure is trusted personnel performing their duties correctly. This section focuses on the procedural issues involved in managing the infrastructure. It discusses unique technical requirements and issues involved with designing, developing, and operating a secure infrastructure as appropriate.

This section assumes a PKI-based infrastructure with a “trusted” root element (ROOT CA) acting as a domain’s signing authority. The root element will be the basis of the domain’s trust relationship among subscribers. The root will enroll authorized infrastructure elements (e.g., subordinate CAs). These authorized elements must ensure that they enroll only other infrastructure elements that they trust. Finally, the CAs will properly identify each subscriber they enroll and ensure that their certificates are correct. The domain’s trust relationship allows subscribers to believe that the information contained in validated certificates is correct.

Building and operating an infrastructure’s trust relationship involves much more than just issuing certificates to the CAs. The KMI/PKI also has to manage itself. This requires the KMI/PKI to develop and enforce acceptable security policies and procedures, manage the key and certificate process to ensure that each element is operating correctly, manage the domain’s external relationships (e.g., determine acceptable cross-certification requirements), and ensure availability. Unique KMI/PKI management requirements include the following:

- Policy creation.
- Policy enforcement.
- Key and certificate accounting.
- Compliance audit.
- Cross-certification.
- Operational requirements (e.g., training, physical, personnel, operating procedures).
- Disaster recovery mechanisms.

All PKI security attacks defined in Section 8.1.2, Certificate Management, apply in equal measure to the infrastructure itself. However, the consequences of the attacks are now greater, and the infrastructure also has to protect itself against a number of new attacks that target its management of the subscribers' keys and certificates. Examples of attacks are as follows:

- Deny global service by taking down portions of the KMI/PKI.
- Substitute attacker's public and private material for KMI/PKI element's material to control the issuing process of subscriber's certificates.
- Destroy the domain's trust relationship via the incorporation of inappropriate elements within the KMI/PKI (e.g., inappropriate cross-certification link).
- Compromise the data recover infrastructure.

Although an attacker could theoretically attack the infrastructure to obtain access to an individual subscriber's information, a more likely scenario is an attacker trying to subvert the infrastructure to gain access to information on a large number of subscribers. This makes the security requirements on the internal KMI/PKI certificates stronger than on the equivalent subscriber's certificates. These increased requirements might be the following:

- Higher assurance in the identification process for KMI/PKI elements.
- Higher assurance in generating keys and certificates for KMI/PKI elements.
- Better protection against compromise.
- Increased mechanisms for the detection of potential compromises.
- Rigorous personnel/physical/procedural security measures.
- Stronger security architecture for limiting and monitoring operator actions.
- Stronger data recover security.

### 8.1.5.1 Policy Creation and Management

One of the most important aspects of establishing and maintaining a trust relation for a KMI/PKI is its security policies. To establish the trust relationship within the domain (and other cross-certified domains), the policy must provide a basis for the subscribers to know and understand the degree of security that the KMI/PKI actually gives them. No KMI/PKI can guarantee that it is totally secure and that there is no possibility that there are unauthorized subscribers. Subscribers must know to what degree they want to accept the KMI/PKI's assurance that the other subscriber with whom they are communicating is the person identified in the certificate. The only way that a subscriber can determine what trust to place in the domain is by examining the KMI/PKI's security-related policy. KMI/PKIs must document their policies for both subscribers' keys and certificates and their own internal keys and certificates. Depending on the trust requirements for the specific application, these policies may range from very tight to fairly loose. Section 8.1.6, KMI/PKI Assurance, discusses how to define policies for applications with different levels of security requirements.

## UNCLASSIFIED

Key Management Infrastructure/Public Key Infrastructure  
IATF Release 3.1—September 2002

The approach to defining security policies for KMIs and PKIs tends to differ in that PKIs are implemented in a global federal, intragovernment, and commercial community, whereas KMIs tend to be operated in smaller national security communities. Consequently, considerable effort has been devoted to developing international standards for PKI certificate policies, whereas KMI security policies tend to follow more local and national intergovernmental standards.

The ITU X.509 standard describes a Certificate Policy as follows:

“...a named set of rules that indicates the applicability of a certificate to a particular community and/or class of application with common security requirements.” [1]

An IETF informational RFC (PKIX 2527 Certification Policy/Practice Statements [5]) that defines a framework for developing policies can be found at <http://www.ietf.org/html.charters/pkix-charter.html>. The policies cover a wide range of issues, from defining the rules for initializing a new infrastructure element or subscriber, to the physical and personnel requirements for the domain, to what happens in an emergency. The Certificate Policy addresses issues such as the following:

- Certification identification requirements.
- Key generation (subscriber/infrastructure, hardware/software, etc.).
- Procedural security requirements.
- Computer security requirements.
- Physical and personnel security requirements.
- Operational policy requirements.
- Requirements on subscribers (e.g., protect key).
- Interoperability requirements (e.g., cross-certification).
- Rekey mechanisms.
- Key and certificate distribution.
- Certificate profile.
- Network security requirements.
- Compromise recovery requirements.
- Liability discussion.
- Types of applications in which the certificate may be used.

Developing Certificate Policies to the IETF Framework has proven extremely valuable in allowing an “apples to apples” comparison of PKI security practices. The IETF 2527 document has become the basis for numerous other Certificate Policy management and evaluation standards worldwide.

Certificate Policies affect the relying parties, subscribers, and those developing and deploying PKIs. They are also the basis for achieving “policy interoperability” among interoperating PKIs. Therefore, the Certificate Policy Management Authority (PMA), or Policy Authority, should consider the interests of all these parties when composing and reviewing the Certificate Policy. Furthermore, because public key certificates are often planned for use in applications having

legal requirements (e.g., financial transactions), legal counsel must be an important part of most Certificate Policy development efforts.

Once created, there are numerous further actions that are necessary to make a Certificate Policy useful. The infrastructure's approach to meeting the Certificate Policy requirements must be documented in one or more CPSs.

Certificate Policies should state high-level security requirements and leave implementation descriptions to lower level documents, such as CPSs. In many ways, the relationship between a Certificate Policy and a CPS is analogous to that between a Request for Proposal (RFP) and a proposal. Authors of a Certificate Policy and an RFP strive to limit their statements to functional or security requirements and not to define specific implementations. Authors of proposals and CPS documents strive to describe specific implementations and need to avoid simply repeating requirements. The PMA is responsible for reviewing CPS documents to ensure they meet the PKI's Certificate Policy requirements.

The CPS documents should be distributed to the PKI elements responsible for fielding and operating the PKI. The KMI/PKI components are procured or designed to the specifications of the approved CPS implementation document, and personnel are trained in the procedures defined in the CPS. During operation, the KMI/PKI must employ mechanisms to enforce—and document—that the CPS provisions are followed correctly by the PKI. Usually, such enforcement consists of a regime of compliance audits conducted by third-party auditors (or other professionals).

Finally, the policies should be periodically reviewed, updated, and distributed to ensure that they still provide the necessary security. Without these actions, the subscribers have no idea how much trust to place in a key or certificate.

Attacks against the policy creation process can disrupt the domain's trust model by misrepresenting the level of security provided by the KMI/PKI. Although this misrepresentation does not lead to any direct attacks against either the KMI/PKI or the subscriber data, it may permit the key or certificate to be used in inappropriate applications where other attacks may be successful.

## 8.1.5.2 Registration

Subscribers typically “trust” the local element that provides their key or certificate because in a normal office environment, the local operator is often someone known to the individual. The subscriber also generically “trusts” the KMI/PKI root, which might be the company personnel office. The KMI/PKI trust relationship relies on the fact that every other infrastructure element—and by inference every other subscriber—is just as reliable as those elements which the subscriber personally trusts. Cross-certification extends the trust relationship to all infrastructure elements in all the other cross-certified domains.

The abilities to approve new CAs and to cross-certify other domains are critical functions that must be strictly limited. Registration is the procedural process for identifying to the

## UNCLASSIFIED

Key Management Infrastructure/Public Key Infrastructure  
IATF Release 3.1—September 2002

infrastructure the people and elements authorized to change the domain's trust relationship. For infrastructure elements, there are normally two separate processes involved. The first reviews the policy implications of adding a new infrastructure element or allowing cross-certification. This is a procedural process done out-of-band by the Certificate PMA. The second process is to implement the policy decision by creating the appropriate certificates. The persons responsible for implementing the decision are the root and CA operators.

When a domain establishes an infrastructure, it will identify the root and CA operators. The CPS (Section 8.1.5.1, Policy Creation and Management), should outline the qualifications, such as clearances and training, for the personnel who assume these roles. The operators must also be registered with the software being used within the system. These operators normally have special accounts for access to the administrative functions at each component. To access these accounts, the operators will need to authenticate themselves to the components through the use of passwords, public key certificates, or hardware tokens. The components need to ensure that these authentication processes are strong enough that an attacker cannot gain access to these special functions. The effect would be that the attacker could enroll an infrastructure and hence unauthorized subscribers.

### 8.1.5.3 Ordering and Validation

The ordering process within the infrastructure consists of two phases: making a request to the registered authority to add a new infrastructure element or cross-certification, and providing the necessary information to generate the certificate (e.g., CA's identity, CA's public key) in a secure, authenticated manner. The ordering process validates the request and provides a mechanism for protecting the integrity of the public key and authentication information. The generation process will bind the authentication information into the certificate.

Although the electronic ordering mechanisms discussed in Section 8.1.2.3, Infrastructure Processes, can establish new KMI/PKI elements, because of the sensitivity, an off-line manual process is more likely. Complicating the issue is the possibility that in many domains, the new element will not be in physical proximity with its superior element. In this situation, the enrolling CA will not be able to personally identify the ordering CA.

Although subscriber's orders require only validation of their identity and the correctness of their certificate information, an infrastructure element must show that they properly implement the domain's policy. This requires that before the KMI/PKI generates a certificate for an infrastructure element, (1) it establishes the need for the new element with its specific set of privileges, (2) the element understands the policy and complies with its requirements, and (3) the people who are operating the element are trustworthy.

Cross-certification is also likely to be an offline manual process. However, it is likely that the two domains will not be in close physical proximity and will not be able to rely on personal identification. Before generating a cross-certification certificate, the KMI/PKI must validate the request. Beyond establishing the identity of the domain and its certificate information, this requires that the KMI/PKI establish the need for a cross-certification with this particular domain,

determine that the policies of the two domains are consistent, and ensure that the other domain complies with its stated policy.

## 8.1.5.4 Key Generation

Please refer to Sections 8.1.2.3, Infrastructure Processes, and 8.1.3, Symmetric Key Management. No unique infrastructure requirements exist. Given the additional threat against the infrastructure, it needs a higher degree of assurance in the keys, which can take the form of longer keys, hardware key generation and storage, or input from multiple elements.

## 8.1.5.5 Certificate Generation

Once a new CA is authorized, the technical process of creating and signing a certificate for the infrastructure and the subscribers is similar to the process for subscriber certificates (Section 8.1.2.3, Infrastructure Processes). The primary difference is that the infrastructure must generate the initial root key and certificate in a unique way. Certificates for the other KMI/PKI elements and subscriber are identical. Some differences may also exist in the certificate's profile, however, because some of the X.509 v3 certificate fields apply only to the infrastructure and some apply only to the subscribers.

The root certificate is unique because it is self-signed; therefore, no higher level device exists that can generate the certificate. This creates a unique process in a security-critical function. The root performs the following activities to initialize the domain.

- Create the domain's cryptographic parameters (when required).
- Output the domain's cryptographic parameters in order to distribute them to the subscribers.
- Generate a public and private signature key.
- Generate a root certificate signed with the private signature key.

The biggest difference in the certificates is that infrastructure certificates populate the constraint and policy fields to limit the ability of a compromised KMI/PKI element to affect other elements. The generation process must ensure that the certificates are appropriate for the certificate's application. The specific fields populated depend on the domain's policy. The federal PKI certificate profile, which can be found at <http://csrc.nist.gov/pki>, identifies the following profile: [6]

The certificate profile identifies four types of certificates with different requirements: root, general CA, cross-certificate, and end subscriber. All types of certificates use the complete set of X.509 base certificate fields except issuerUniqueIdentifier and subjectUniqueIdentifier. The various certificates differ in the extension fields. The root certificate populates only two extensions: subjectKeyIdentifier, which identifies the specific root key being used, and basicConstraints, which identify it as a CA. The CA and cross-certification certificates are

similar. They must process (although not necessarily use) all extensions except `privateKeyUsagePeriod` and `subjectDirectoryAttributes`. Three fields—`policyMapping`, `nameConstraints`, and `policyConstraints`—used in infrastructure certificates are not used in subscriber certificates. The profile identifies other differences in the specific fields for each extension.

The root private key is the most valuable key in the domain. If compromised, the attacker can create unauthorized certificates that allow him to masquerade as anyone in the domain. Because the root certificate is self-signed, it is uniquely vulnerable to substitution attacks. If an attacker can get a subscriber to believe that the subscriber's self-signed certificate is from the root, then the attacker can issue certificates that the subscriber will believe are valid. Also, if an attacker can force the root to use a known key or generate a key susceptible to cryptographic attack, then they can generate their own root certificate. Also, it is likely that there will be a stored copy of the signature key in case of a root failure. If the root fails and there is no signature backup, the entire domain must be reinitialized with the new root certificate. These security issues highlight the extreme care that the infrastructure must take to protect the root key and any copies that might exist.

### 8.1.5.6 Distribution

The KMI/PKI must ensure that all subscribers in the domain have authenticated access to the necessary system information and certificates. The directory discussed in Section 8.1.4, Infrastructure Directory Services, will be one method of distribution of certificates and other parameters. The infrastructure has to distribute four items: the system parameters, its own certificates, compromise recovery data, and subscriber certificates.

The authenticated delivery of the system parameters, including the domain's cryptographic parameters (when available) and the root certificate, are security critical because they are the foundation of the domain's trust relationship. Although they are public values, their authenticity is critical to the correctness of the subscriber's certificate validation process. The parameters, created by the root during system initialization, are used by the CAs during the generation of other certificates. Distribution mechanisms may include a directory, off-line distribution, or local distribution through the CA. The KMI/PKI must also ensure that all subscribers have authenticated access to its certificates and compromise recovery information.

After certificate generation, the KMI/PKI provides the subscriber with certificates. Before activating a new certificate, the infrastructure and subscriber should check that the certificate was generated properly. The infrastructure must check that the certificate owner has access to the private key that corresponds to the certificate's public key. Proof of Possession (POP) is one protocol solution for performing this check. The subscriber must check that the certificate contains the correct public key and subscriber information. After completing the checks, the subscriber indicates that the infrastructure should post the certificate.

## 8.1.5.7 Accounting

The KMI/PKI has to be able to track the location and status of keys and certificates throughout their life cycle. There will likely be a requirement to archive the accounting information because of the legal need to be able to document the life history of a key or certificate for as long as the signature might need to be verified. The accounting information for each certificate should provide, at a minimum, the certificate contents plus the applicable information for each task, including the following:

- Task.
- Time.
- Status (completed/error).
- Operator involved.
- Element that originated the task (e.g., where did the order originate).
- Other element(s) involved in the task.
- Acknowledgment from other element(s) involved.

Accounting has real-time security and administrative requirements. It provides a security service by allowing the check that each step of the process was proper (e.g., the certificate generation process checks the status of the order validation) before the beginning of the next task.

Accounting also tracks the interaction between various components by requiring each element to acknowledge to other involved elements that it has completed its portion of the processing.

The primary use of an account is administrative. The system needs to be able to track the history of keys and certificates in case of future challenges to its authenticity. Accounting is useful for the following tasks:

- Showing an outside observer the infrastructure life cycle for any key.
- Proving to an outside auditor that the policies and procedures were followed correctly.
- Providing damage assessment of operator actions if an operator is subsequently shown to be untrustworthy.
- Recording certificate information from the ordering process.
- Archiving a key's history.
- Archiving a token's history.

Depending on the KMI/PKI architecture, a single element or many elements can perform the accounting. All accounting records must be protected against accidental deletion or modification, or malicious attacks. If several elements perform accounting, either for one key or certificate or because multiple certificates from different elements reside on one token, there is an additional issue of coordinating the partial accounting records into a complete, authenticated set of records.



## 8.1.5.8 Compromise Recovery

An infrastructure element can compromise either its signature key or key agreement key. The compromise of a KMI/PKI element's key agreement key is the same as for a subscriber's key (Section 8.1.2.3, Infrastructure Processes).

Because the compromise of an infrastructure element's signature key invalidates all lower level certificates that include the element in their validation path, it is the more serious problem. This includes not only the direct certificates it created for lower level CAs and subscribers but also any certificates created by the CAs. It is critical that the infrastructure be able to reenroll the affected elements and subscribers quickly and painlessly, while removing any unauthorized subscribers enrolled by the compromised element. The infrastructure must be able to inform the subscribers and cross-certified domains about an infrastructure compromise quickly and accurately, while rapidly rekeying the affected elements and subscribers. The responsibility for informing the subscribers resides in the element that enrolled the compromised element. The mechanisms for notifying subscribers about the compromise of an infrastructure certificate are the same as those defined in Section 8.1.2.3, Infrastructure Processes, a CRL or online verification.

For a compromised root, the same mechanisms theoretically work, but it is unclear whether the applications support will be there. Possible solutions include placing the root certificate on a root generated CRL, placing the root certificate on the PCA CRL, or performing online verification. When checking a CRL, normal processing is to look for the certification on the CRL from the enrolling CA. Both possible CRLs for the root (its own or from a subordinate CA) are exceptions to this processing, and it is unclear if the applications will support them. Online verification protocols are still in the design stage, and it is unclear if they will report the root as compromised. Alternative workarounds, such as placing every CA on the appropriate CRL, may meet the requirement.

The recovery process for reenrolling subscribers is straightforward, but the process must be performed quickly to minimize the impact on the subscribers. Starting at the compromised element, it generates a new public and private key pair and a higher level element generates and signs and distributes the new certificate. Once the element is operational again, it can begin to reenroll its subscribers. The reenrollment process requires a revalidation of every subscriber, using any of the mechanisms outlined in Section 8.1.2.3, Infrastructure Processes. An issue is how to deal with the occasional PKI subscriber who has not tried to validate a certificate since the compromise. Subscribers will not realize they need to be reenrolled. The infrastructure can allow them to continue to have an unusable certificate, or it can contact them about being reenrolled. Lists of subscribers should be available from either the local accounting records or the directory.

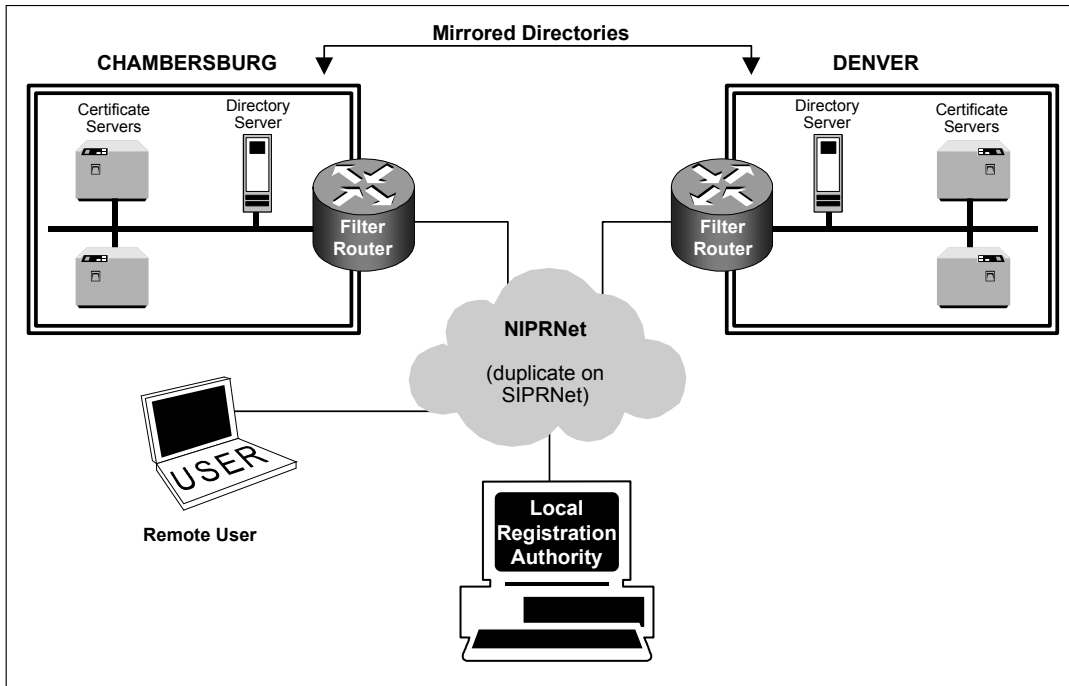

iatf\_8\_1\_14\_0053

Figure 8.1-14. DoD Class 3 PKI Architecture

### 8.1.5.9 Rekey

An infrastructure element's rekey process differs for key exchange key and signature key. An infrastructure element's key exchange key is similar to a subscriber's rekey addressed in Section 8.1.2.3, Infrastructure Processes. Signature rekey has major effects on the CAs or subscribers created by the element; therefore, the KMI/PKI must give strong consideration to how often it will rekey the infrastructure elements. The consequence of rekeying an infrastructure element's signature key is that every certificate in its verification chain must also be rekeyed. This action creates a tradeoff between security and subscriber friendliness over the frequency of rekey. Security considerations push for frequent rekeys because of the consequence of an undetected compromise or a crypt-analytic attack of an infrastructure element. Subscriber friendliness demands infrequent rekeys because of the impact on the subscribers of rekeying the infrastructure.

The security tradeoffs are straightforward. The private signature key of an infrastructure element is a high value target because a compromise allows an adversary to masquerade as anyone in that element's domain. The longer the key remains in use, the greater the incentive for attacking it, and the better chance the adversary has of being successful. Once the element is rekeyed, the old signature key has no value.

Infrastructure rekey operational issues that should be included in the process are listed below.

## UNCLASSIFIED

Key Management Infrastructure/Public Key Infrastructure  
IATF Release 3.1—September 2002

- There should be a graceful rollover to the use of new keys without a period of community isolation or noninteroperability.
- Revocation notification must be maintained during the rollover. This means that KMI/PKIs will probably maintain multiple, simultaneously current CRLs.
- Note that a CMA may continue to sign CRLs with the old key, long after it has ceased signing certificates with that key and until the last certificate signed with that key expires and its CRL-inclusion period passes.
- It should be possible to issue certificates that will not fail validation because of expired signing authority certificate (i.e., the requested certificate should verify for a reasonable time period even when issued just before rekey of the signing authority). (This action is often accomplished by making the signing authority certificate validity period longer than the signing authority private key usage period.)
- The issuance of certificates should not be unreasonably delayed when authority rekey is pending—that is, an end subscriber certificate request should not kick off an authority rekey, possibly extending to multiple levels of the hierarchy, for which the subscriber must wait.
- The mechanism will have to live within the constraints of the cryptographic token(s) employed at the time of its introduction.

One method of minimizing the subscriber impact is to use the current key to authenticate the new key. The steps to initiate this action are listed below.

- The Root CA generates a new key and creates a new certificate with its public key signed with the current signature key.
- The Root CA also creates a new certificate for the current key and signs it with the new signature key.
- Subscribers needing the old CA certificate containing the old key must cache it locally because it will not be available from the directory.
- All subordinate subscribers and authorities should be notified of the impending rekey so that they can cache the certificate containing the old key and, probably, the last CRL signed by the old key.
- Applications must recognize when data is signed using a private key associated with an old certificate and obtain the old certificate from its cache.
- Applications may have to forego checking of current CRLs issued by the rekeyed authority and incur the associated risk.
- All subscribers and authorities whose certificates were signed by a rekeyed authority should obtain as quickly as possible new certificates, signed by the new key.

CAs will continue to issue CRLs signed by the old key until one CRL-inclusion period after the expiration of all certificates they have issued. Therefore, subscribers can continue to be notified of revocations of certificates signed by the old key.

When it is time for the Root CA to rekey, the subscriber can validate the signature regardless of which key the sender and recipient have. For example, if the Root CA and the sender have both been re-keyed but the recipient hasn't, the recipient's validation chain would be as follows: the sender, its CA(s), the new Root CA certificate, and finally the new Root CA certificate signed with the old signature key. Once the Root CA begins its rekey process, each CA can use a similar process to generate its new keys.

### **8.1.5.10 Destruction**

Please refer to Section 8.1.2.3, Infrastructure Processes.

### **8.1.5.11 Key Recovery**

There are two separate issues about key recovery in the infrastructure. The first deals with how KMI/PKI elements perform key recovery. The second deals with the issues involved in developing a key recovery infrastructure.

#### **Key Recovery for KMI/PKI Elements**

There are no easy answers about the requirement for key recovery in infrastructure elements. The requirement depends on the policy of the domain. This section defines some of the tradeoffs in the key recovery policy.

In general, signature keys do not need key recovery. The signature key serves no law enforcement purpose and the subscriber suffers no great inconvenience in getting a replacement signature key. Within the infrastructure, however, the enormous impact of rekeying the element and its subscribers for lost or destroyed keys (Section 8.1.5.9, Rekey) drives the requirement for key recovery of certain signature keys. The policy can limit key recovery to only certain elements. Even if some elements, such as the root, require key recovery, other elements within the infrastructure do not. Given the obvious security ramifications of storing signature keys, a robust recovery system must be in place to protect keys against all unauthorized access. The key recovery policy for KMI/PKI element's key agreement keys is the same as for any other domain subscribers.

#### **Key Recovery Infrastructure**

There is no one key recovery infrastructure. Either the certificate management infrastructure or a completely separate infrastructure can perform key recovery. The regular certificate management infrastructure would store encrypted keys at the CAs. Advantages include no additional people with access to the key and lower cost, and infrastructure employees could already exploit the keys through other attacks. A separate infrastructure could use any approved

method. Advantages include potentially tighter security for the keys and no political fallout for the certification management infrastructure. The next section describes a generalized recovery architecture based on the draft Key Recovery Federal Information Processing Standard (FIPS).

## Generalized Key Recovery Model

The key recovery system model defines the minimal set of system components needed to perform key recovery. The key recovery system model is a generalized model that supports a wide variety of different key recovery techniques and data applications. The key recovery system model contains the following components, as a minimum:

- System A (Encryption-enabled).
- System B (Encryption-enabled).
- Recovery Information Medium (RIM).
- Key Recovery Requester System (Requester System).
- Key Recovery Agent(s) (KRA).

The model depicts a key recovery system capable of creating key recovery information (KRI) and recovering the key from the KRI.

The three components—System A, System B, and the KRI medium—collectively define the “Key Recovery Enablement Process.” The process also includes an encrypted data medium and a key distribution medium. The encrypted data medium and key distribution medium are the “locations” where the encrypted data and data encryption key are stored or communicated, respectively.

The process of encrypting data and creating KRI is divided between one or more encryption-enabled systems, denoted in the key recovery system model as System A and System B. An encryption-enabled system can encrypt and decrypt data. System A, System B, or both need the ability to create KRI. However, the key recovery system model does not prescribe which system or systems must have a key recovery capability. The RIM maintains the KRI produced by these systems. The RIM may exist over multiple “locations”, and may be in the same or different location from the encrypted data and key distribution mediums.

The RIM represents the “locations” where the KRI is stored or communicated, such as a storage device or a communications channel. The key recovery system model does not prescribe how or where the KRI must be stored or communicated, so long as the RIM is available. To allow interoperability between various key recovery schemes, a standard format for KRI on the RIM is essential. Each scheme has a distinct set of information that must be present in order to allow key recovery. A key recovery field (KRF) contains this information. To ensure the integrity of the KRF, the association of the KRF with the encrypted data, and to provide the identities of the key recovery scheme in use and the appropriate KRAs, a key recovery block (KRB) contains the KRF.

The KRI itself is managed or handled in a variety of ways. It may exist for only a brief time during electronic transmission, or it may exist for a relatively long time on a storage device.

The Requester System and the KRA form another subportion of the key recovery system model called the Key Recovery Process. The Requester System and KRAs handle the process of recovering a key from the KRI. They access the encrypted data medium and the RIM and interact with one or more KRAs using a Requester System to recover a cryptographic key from the KRI.

A recovered key can then be used to recover the data, either directly or indirectly, using a Data Recovery System. The data encrypting key is recovered directly when the recovered key is the same key used to encrypt the data. Indirect key recovery occurs when the recovered key is a key encrypting key used to decrypt or recover the data encrypting key.

## Requirements

This section defines some of the security requirements on a key recovery infrastructure and its elements. It discusses a high assurance commercial-level recovery infrastructure. Depending on the application, higher or lower assurance infrastructure may be appropriate.

### *Key Recovery Agent Requirements*

- **Cryptographic Functions**—All cryptographic modules shall be FIPS 140-1, Level 3 compliant.
- **Cryptographic Algorithms**—The key recovery scheme shall be at least based on using only FIPS algorithms. The implementation of these algorithms shall conform to the applicable FIPS standard(s) (Same as Level 1).
- **Confidentiality**
  - The KRA shall protect KRI stored against disclosure to unauthorized individuals.
  - The KRA shall protect KRI transmitted against disclosure to parties other than the requester(s).
  - The KRA shall prevent any single subscriber or mechanism from compromising the confidentiality of the KRI.
- **Audit**
  - The product/system shall be able to generate an audit record of the following auditable events.
    - Start-up and shutdown of the audit functions.
    - All auditable events as defined in the system security policy.
  - Examples of auditable events include the following.
    - All requests to access subscriber authentication data.
    - Any use of the authentication mechanism. The authentication information shall not be stored in the audit trail.
    - All attempts to use the subscriber identification mechanism, including the subscriber identity provided.
    - The addition or deletion of a subscriber to or from a security administrative role.
    - Requests, responses, and other transactions generated by the product/system.

## UNCLASSIFIED

Key Management Infrastructure/Public Key Infrastructure  
IATF Release 3.1—September 2002

- Requests, responses, and other transactions received by the product/system.
  - The invocation of the nonrepudiation service.
  - The audit event shall include identification of the information, the destination, and a copy of the evidence provided. The event shall exclude all private and secret keys in encrypted or unencrypted form.
  - The product/system shall be able to associate any auditable event with the identity of the subscriber that caused the event.
  - The product/system shall be able to generate a human understandable presentation of any audit data stored in the permanent audit trail.
  - The product/system shall restrict access to the audit trail to the authorized administrator.
- **Identification and Authentication**
    - The product/system shall provide functions for initializing and modifying subscriber authentication data.
    - The product/system shall restrict the use of these functions on the subscriber authentication data for any subscriber to the authorized administrator.
    - The product/system shall protect authentication data that is stored in the product/system from unauthorized observation, modification, and destruction.
    - The product/system shall be able to terminate the subscriber session establishment process and disable the subscriber account after five unsuccessful authentication attempts until an authorized administrator enables the account.
    - The product/system shall authenticate any subscriber's claimed identity before performing any functions for the subscriber.
- **Access Control**
    - The product/system shall verify applicable authentication and integrity services for the received transactions as determined by the standard compliant protocol.
    - The product/system shall apply applicable authentication, integrity, and confidentiality services to all transactions, i.e., requests and responses, as determined by the standard compliant protocol.
    - The product/system shall release the keys only to authorized subscribers.
    - The KRA shall release the key only if the requester is authorized to receive the key associated with the subscriber specified in the request and for the validity period (time) if specified in the request.
    - The product/system shall ensure that security policy enforcement functions are invoked and succeed before any security-related operation is allowed to proceed.
    - The product/system shall restrict the ability to perform security-relevant administrative functions to a security administrative role that has a specific set of authorized functions and responsibilities.
    - The set of security-relevant administrative functions shall include all functions necessary to install, configure, and manage the product/system. Minimally, this set shall include assignment/deletion of authorized subscribers from security administrative roles; association of security-relevant administrative commands with security administrative roles; assignment/deletion of subjects whose keys are held;

- assignment/deletion of parties who may be provided the keys, product/system cryptographic key management, actions on the audit log, audit profile management, and changes to the system configuration.
- The product/system shall allow only specifically authorized subscribers to assume only those security administrative roles for which they have been authorized.
  - The product/system shall define a set of security administrative roles that minimally includes security administrator, system operator, cryptographic officer, and audit administrator.
- **Nonrepudiation**
    - The KRA shall be able to generate evidence of receipt for received transactions.
    - The KRA shall be able to generate evidence of receipt of registration or deposit of KRI from subscribers.
    - The KRA shall be able to generate evidence of receipt of requests from requester.
    - The product/system shall generate evidence of origin for transmitted key recovery requests or responses.
    - The product/system shall provide a capability to verify the evidence of origin of information to the recipient.
    - The product/system shall provide a capability to verify the evidence of receipt of proof of receipt to the originator of message, i.e., recipient of proof of receipt.
    - The product/system shall provide the originator the ability to request evidence of receipt on information.

### *Availability*

The KRA shall provide a secure replication of any KRI stored.

### *Protection of Trusted Security Functions*

- The product/system shall provide a communication path between itself and local human subscribers that is logically distinct from other communication paths and provides assured identification of its endpoints.
- The local human subscribers shall have the ability to initiate communication via the trusted path.
- The product/system shall require the use of the trusted path for initial subscriber authentication.
- The product/system shall provide the authorized administrator with the capability to demonstrate the correct operation of the security-relevant functions provided by the underlying abstract machine.
- The product/system shall preserve a secure state when abstract machine tests fail.



### ***Policy***

The KRA shall have a written policy based on the KRA Policy Framework. It shall operate in accordance with this policy.

### ***Registration Agent***

Agents should protect all sensitive information from modification.

- **Nonrepudiation**—The RA shall be able to generate evidence of receipt for received transactions.
- **Integrity**—The RA shall be able to provide proof that information maintained has not been altered.

### ***Licensing Agent***

Licensing Agents shall perform compliance audit of the KRA to ensure that the KRA operates in accordance with the KRA's stated policy.

## **8.1.5.12 Administration**

Having good policies and technical solutions will not ensure the secure operation of a KMI/PKI or the validity of the subscriber certificates. An extensive set of operational policies and practices supporting the technical solutions also has to be in place. Historically, many problems found with infrastructure have not been with the technology but with poor procedures; the operator did not know what to do in a given situation or the operator did not follow the proper procedures.

Administration of the infrastructure involves much more than the procedures to identify subscribers and create their certificates. It also requires managing the people, the components, and the networks making up the KMI/PKI. Because of the wide range of activities that impact the KMI/PKI's security, the administration function is spread across a large number of people. Each of them must do their jobs correctly to have the level of trust defined in the policy. Specific tasks include—

- Enforcing policy (e.g., compliance audits).
- Administrating the network and system elements.
- Managing the technical security mechanisms for the infrastructure elements (e.g., administrating the computer's access control list, reviewing the audit files).
- Performing key and certificate accounting.
- Managing the cross-certification process.

## UNCLASSIFIED

- Managing the compromise recovery process.
- Defining and documenting operational and security procedures.
- Training operators.
- Managing physical and personnel security.
- Providing disaster recovery mechanisms.
- Maintaining availability.
- Managing the key recovery process.

Establishing the KMI/PKI's trust relationship via a set of policies (Section 8.1.5.1, Policy Creation and Management) is the first step, but the trust model has to be continuously managed or it will become meaningless. The policies have to be translated into operational and security procedures for the specific technical solution employed within the KMI/PKI. These procedures provide a framework for the operators to administer the system. The procedures should cover all the normal processes in running the KMI/PKI and known exception and emergency activities. These procedures have to be documented and distributed to all appropriate KMI/PKI elements. The infrastructure should periodically reexamine and update the procedures as the policy changes, new processes are added, new exception cases are identified, new technical solutions are employed, or better ways of administering the policy are found.

Once the infrastructure identifies and documents the procedures, the operators must be trained in the system policy and related procedures. Beyond the technical procedures necessary for their jobs, the operators must have an understanding of their responsibilities and limitations, and the security implications of not following the procedures. This process is open-ended because as the policy and procedures change, the operators need to be retrained.

The infrastructure has a responsibility to its subscribers and other domains to uphold its end of the trust relationship. This requires a mechanism to monitor the actions of every element in the KMI/PKI to ensure that they correctly implement the policy and procedures. Compliance audits, based on traditional concept of key management audits, are one way of tracking the subordinate elements. The root (or designated agent) periodically reviews each element to check the degree of compliance with the policy and procedures. The audit should also test little used and contingency procedures to determine if the operators would respond correctly. The results should identify and help correct problems with elements not properly implementing the procedures. Results should be available to other people in the trust relationship (e.g., domains that are cross-certified).

One of the most important extensions of the trust relationship is the addition of outside domains through a cross-certification. In effect, this gives every subscriber in the outside domain the same trust characteristics as an original member of the domain. This requires that the new domain have an equivalent level of assurance as the original domain (and vice versa). The only way to determine if this equivalency exists is to examine the two policies and determine whether they provide equivalent degrees of assurance. Standardizing on the format for documenting

## UNCLASSIFIED

Key Management Infrastructure/Public Key Infrastructure  
IATF Release 3.1—September 2002

policies helps in comparing the policies by allowing a straightforward comparison of parallel certificate policy elements. One caution is that it is almost impossible to determine if the other domain actually implements their policy correctly (no independent compliance audit). The domains are trusting the correct enforcement of the other's domain security policy. Each domain has to monitor the other domain's performance and revoke the cross-certification link at any sign that it does not implement its policy correctly.

Because trust is the fundamental characteristic of the KMI/PKI, the physical and personnel security is important. A system operator can do extensive damage to the system and subscribers throughout the domain who rely on the certificates they authorize. Consequently, the people who have authorized access to the system must be trusted to do their jobs honestly, while all unauthorized subscribers are prevented from accessing the KMI/PKI.

Personnel security consists of both the hiring of the operators and their continued supervision. The owners of the infrastructure should perform some level of investigation (as defined in the policy) on their prospective employees to gain confidence in their trustworthiness. Periodic reinvestigations are necessary to maintain that degree of trust. If these reinvestigations or other actions bring their trustworthiness into question, those operators should be temporarily removed from access to the system. If further investigation confirms the suspicion, the keys and certificates they created may need to be revoked

Physical security provides for the isolation of the KMI/PKI elements from access by unauthorized people. Protection is required for both the physical elements and their relevant KMI/PKI information. The policy should define the level of protection required. Because of the different sensitivities of elements within the infrastructure, the protection may vary. For example, the root might be located in a no-lone, i.e., an area where two-person integrity is required, zone protected with a 24-hour guard while a low level CA might only need a lockable protective container.

The technical security requirements must also be managed. These include the computers and networks that are used to implement and transport the infrastructure and its products. While these do not provide subscriber services, they are susceptible to attacks. If corrupted, they can negate other security mechanisms in the system. The infrastructure needs the same set of services (e.g., computer security, network confidentiality, intrusion detection, as other applications), so many of the solutions defined in Chapter 5 are applicable to the KMI/PKI.

The system administrators for the network, firewalls, and computer systems have to ensure that the underlying equipment works and provides the necessary security. The system administration should be a unique role and not done by an operator. The network administrator is responsible for providing network security services, e.g., authentication, access control, availability, and protection from network attack, and setting up the firewall. The computer system administrator is responsible for providing computer security services (e.g., least privilege, review audit files, access control, and virus protection). They have to install the computer equipment, set up operator accounts, define operator access privileges, monitor operator activities, install new software, and install security software and patches. Administrator actions should be part of the compliance audit.

The KMI/PKI has to maintain its continuity in the face of an emergency that destroys infrastructure elements or during the routine elimination of existing infrastructure elements. That requires advance planning for each of the elements and the definition of appropriate disaster recovery mechanisms. Operators need to be trained in the recovery procedures, and they should be tested as part of the compliance audit. The disaster recovery plans should guarantee the availability of the following services and information:

- Ability for subscribers to access certificates and compromised information.
- Ability to generate and distribute compromise information.
- Ability for subscribers to verify existing certificates.
- Archived records.
- Key recovery information.
- Authenticated copies of the old system parameters, e.g., root public key.
- Ability to reconstitute KMI/PKI with existing elements by creating new root and adding new elements as appropriate.

## 8.1.5.13 Requirements

Requirements related to the operation of the KMI/PKI include the following:

- The KMI/PKI shall ensure that a key or certificate request comes from an authorized source.
- Before issuing a key or certificate, the infrastructure shall verify that all the information within the request is valid.
- The CA shall authenticate a subscriber requesting a certificate to ensure that the correct public key is bound to the proper identity.
- The CA shall notify a subscriber when it has generated a certificate for that subscriber.
- With the exception of special circumstances (e.g., revocation attributed to firing an employee), the CA shall notify a subscriber when it has revoked the subscriber's certificate.
- The KMI/PKI will notify all subscribers of a revocation of a symmetric key.
- The KMI/PKI shall provide timely key and certificate revocation information to its subscribers.
- CAs shall provide their public key and/or public key certificates to subscribers in a secure and authenticated manner.
- A CA shall protect the private key material that it uses to sign certificates.

## UNCLASSIFIED

Key Management Infrastructure/Public Key Infrastructure  
IATF Release 3.1—September 2002

- The CA shall only use its signing private key material to sign certificates.
- If the KMI/PKI generates either symmetric keys or asymmetric key material on behalf of a subscriber (e.g., traffic encryption key or key agreement key material), the infrastructure shall ensure that the material is generated securely and securely distributed to the subscriber.
- If the KMI/PKI stores subscriber private key material for recovery purposes, the infrastructure shall ensure that this information is protected in storage and is revealed only to the subscriber or to an authorized authority. It shall also ensure that the recovery key material is securely distributed to the subscriber or authorized authority.
- The KMI/PKI shall define a policy for the domain and ensure that all elements operate within the scope of that policy.
- The KMI/PKI shall account for the life cycle (ordering, generation, distribution, rekey, destruction and archive) of symmetric key and asymmetric key materials and certificates.
- Proper technical and procedural controls shall be implemented to protect the components of the KMI/PKI.

### 8.1.5.14 Attacks and Countermeasures

#### Attacks

Attacks that can be mounted against the KMI/PKI as a whole or to individual KMI/PKI components include the following:

- **Sabotage.** The KMI/PKI components or hardware token on which the subscribers or infrastructure elements keys and certificates are stored may be subjected to a number of sabotage attacks, including vandalism, theft, hardware modification, and insertion of malicious code. Most attacks are designed to cause denial of service. However, attacks such as hardware modification and insertion of malicious code may be used to obtain copies of subscriber or CA key material as they are generated, obtain information entered by the subscribers or operator such as a PIN, or cause known keys to be generated.
- **Communications Disruption/Modification.** Communications between the subscribers and the KMI/PKI components could be disrupted by an attacker. The disruption could cause denial of service, but may also be used by the attacker to mount additional attacks such as the impersonation of a subscriber or the insertion of bogus information, such as a key order, into the system.
- **Design and Implementation Flaws.** Flaws in the software or hardware on which the subscriber depends to generate and/or store key material and certificates can result in the malfunction of the software or hardware. These malfunctions may deny services. The flaws may accidentally or be intentionally exploited to disclose or modify keys or

certificates. Improper installation of the software or hardware may also result in similar consequences.

- **Operator Error.** Improper use of the KMI/PKI software or hardware by the operators may result in denial of service or the disclosure or modification of subscriber's keys and certificates.
- **Operator Impersonation.** It is possible that an attacker may impersonate a legitimate KMI/PKI operator. As an operator, the attacker would be able to do anything a legitimate operator could do such as generate key, issue certificates, revoke certificates, and modify other infrastructure data.
- **Corruption or Coercion of the KMI/PKI Operator.** It is also possible that a KMI/PKI operator might be corrupted or coerced by an attacker to generate unauthorized key, issue certificates to an unauthorized subscriber, revoke certificates of legitimate subscribers, and modify other infrastructure data.

## Countermeasures

Countermeasures that may be implemented to protect the KMI/PKI and its components from the attacks outlined above include the following:

- **Physical Protection.** Physical protection of KMI/PKI component hardware, communications link with other infrastructure elements, and/or hardware tokens will counter many of the sabotage and communications disruption related attacks.
- **Good Design Practices.** Concerns over flaws in the software and/or hardware design may be alleviated if good design practices are followed during the development of the software and/or hardware used in conjunction with the KMI/PKI.
- **Testing.** Testing of the software and/or hardware may also be used to counter attacks to the system that result from the exploitation of flaws in the system.
- **Training.** Training of the KMI/PKI operators and administrators is vital to eliminating or at least reducing the possibility of inadvertent attacks as a result of subscriber error.
- **Strong Authentication.** Strong authentication of the subscriber by the KMI/PKI components greatly reduces the possibility of impersonation attacks.
- **Access Controls.** Software or hardware based access controls may be implemented at the KMI/PKI components to limit the possibility that an unauthorized attacker will gain access to the infrastructure software or hardware.
- **Encryption.** Encryption of the link between the subscriber and the KMI/PKI components reduces the possibility that an attacker may eavesdrop on the communications and try to disrupt or modify the communications.

- **Contingency Planning/System Backup.** —Backup of a subscriber's keys, certificates, and relevant software and hardware is the best mechanism for protecting against design flaws that result in system failure.
- **N-Person Controls.** Requiring multiperson control on sensitive PKI functions, such as the process of bringing a CA to an operational mode and the generation of CA key material, can limit coercion related attacks.
- **Auditing.** Auditing may not prevent attack, but it may be used to detect an attack and to identify the culprit. The presence of good auditing capabilities may also act as a deterrent to some attackers.
- **Personnel Selection and Screening.** Personnel chosen to perform KMI/PKI functions should be selected on the basis of loyalty and trustworthiness. People performing such functions should be adequately paid, and screened for a prior history, which would indicate a pattern of untrustworthiness.

## 8.1.6 KMI/PKI Assurance

Section 8.1.1, KMI/PKI Introduction, addressed the KMI/PKI as a menu with a set of independent processes with independent solutions. However, a KMI/PKI's security is actually based on the interaction among all the processes. Because the intelligent attacker will always attempt the easiest attack that meets their goals, it makes little sense to have processes at vastly different levels of security. The effect is only to drive up the development and operational costs without increasing the security posture. A better approach would be to determine the security level needed for each application supported by the infrastructure and to choose a set of solutions that correspond to that security level.

Providing a high-assurance KMI/PKI can be very expensive in terms of people and money. Cost effectiveness of many applications, like informal messaging, Web browsing, or those handling low amounts of money, are very sensitive to PKI costs. For these applications, the KMI/PKI cannot cost more than a fraction of the potential loss from a successful attack. These applications may be willing to settle for a KMI/PKI that provides low cost certificates, but does not have all of the procedural and technical protections in place against certain attacks. In effect, KMI/PKI security is a form of insurance and employs the same cost considerations. A \$1 certificate is acceptable for protecting a \$100 transaction, but a \$50 certificate is not appropriate to protect the same \$100 transaction. Other applications may be willing to pay the added cost for better procedural and technical protections because the certificate is protecting more valuable information. A \$50 certificate might be acceptable if it is protecting a \$100,000 transaction.

There is much ongoing work in the standards community and the Government in grouping the individual process solutions into fully developed architectures with common security standards. Among the groups working to define these standards are the IETF, FPKI, DoD, Canadian government, and commercial certificate providers.

## 8.1.7 KMI/PKI Solutions

Examples of KMI/PKI usage will illustrate the practical aspects of system design. Three categories of systems—DoD, Government, and corporate, each with important design and functional characteristics—are presented. Each example of the KMIs is actively involved in upgrading its information assurance (IA) assets and applications. The first category presented begins with summaries of the DoD Class 3 PKI and the FORTEZZA PKI followed by a detailed description of the target DoD KMI/PKI system showing its architectural development concerns, considerations, and issues. The lengthy description typifies the broad aspects of planning and considerations associated with a secure infrastructure implementation plus the added protections needed for processing classified information. This example demonstrates the challenge of designing a large system in today's environment. The DoD anticipates continued growth in the demand for security support for classified applications and Class 3 and Class 4 PKI capabilities. The Government KMI/PKI Solutions category will be presented next to show the many similarities with the DoD KMI/PKI despite its emphasis on UNCLASSIFIED//FOR OFFICIAL USE ONLY (U//FOUO) information. An example from the U.S. Government will be presented. The Federal KMI/PKI description includes the concept of bridging trust paths among PKI communities. The Corporate Solutions category is filled with a myriad of commercial-off-the-shelf (COTS) products and services. Several are presented followed by a summary sketch of a corporate system. A short description using Kerberos for KMI security is provided to show some of the work being performed in academia.

### 8.1.7.1 DoD Class 3 PKI

The following summary highlights the DoD Class 3 PKI.

#### **PKI Name**

The PKI name is the Department of Defense Class 3 Public Key Infrastructure (DoD Class 3 PKI). The original term, “medium assurance,” may be used interchangeably with the term, “Class 3.”

The following summary highlights the Department of Defense Class 3 Public Key Infrastructure (DoD Class 3 PKI) Solution, a forerunner of the DoD Target KMI/PKI described later.

#### **PKI Design and Operational Responsibility**

The overall program management of all DoD efforts required to meet the goals and milestones in the DoD PKI Roadmap is the responsibility of the DoD PKI Program Management Office (PMO). The National Security Agency (NSA) is the PMO Program Manager with the Defense Information Systems Agency (DISA) providing the Deputy Program Manager leadership.

NSA is responsible for defining the security architecture and security criteria for the DoD PKI. This includes criteria for the components and their operation. NSA (or an approved National



## UNCLASSIFIED

Key Management Infrastructure/Public Key Infrastructure  
IATF Release 3.1—September 2002

Information Assurance Partnership [NIAP] vendor) will evaluate the security of products and services employed in the DoD PKI. Figure 8.1-14 illustrates the architecture of the current DoD Class 3 PKI, minus the Root CA. The Class 3 PKI Root CA is located at the NSA Central Facility.

### **PKI Subscriber Community and Applicability**

One element of the Defense-in-Depth strategy is the use of a common, integrated DoD PKI to enable security services at multiple levels of assurance. The DoD PKI provides a solid foundation for IA capabilities and general-purpose PKI services (e.g., issuance and management of CRLs in support of digital signature and encryption services) to a broad range of applications, at levels of assurance consistent with operational imperatives.

Classes 3 and 4 have been defined to support the protection of nonclassified mission critical, mission support, administrative, or format sensitive information on open networks (i.e., unencrypted networks). These PKI classes also can be used on closed networks (i.e., encrypted system-high networks such as Secret Internet Protocol Router Network [(SIPRNet)]) to provide additional protection such as subscriber authentication and data separation/communities of interest (COI). Specifically, Class 3 certificates and applications are appropriate for many business transactions, in which the monetary value of the transaction or the sensitive or unclassified information protection is moderately high. By contrast, the Class 4 PKI products and services will be used to protect sensitive or unclassified mission critical information in a high-risk environment such as the Nonclassified Internet Protocol Router Network (NIPRNet). In addition, the Class 5 PKI products and services (still in the planning stages) will be used for the protection of classified information on open networks or in other environments in which the risk is considered high.

### **PKI Products**

The DoD PKI uses COTS products to keep up with technology evolution and develops government off-the-shelf (GOTS) solutions when necessary. The newness of standards and products, however, may cause some interoperability problems among vendors' products. The DISA and NSA actively work with vendors and standards communities to develop standard specifications and implementations that improve interoperability. The DoD is committed to ensuring that DoD specifications are consistent with the emerging commercial and National Institute of Science and Technology (NIST) federal standards to support DoD interoperability requirements.

### **PKI Future Plans and Schedule**

The majority of activity to date in the DoD PKI arena has focused on understanding the technology, the standards, operational policy and procedural issues and on establishing the role of PKI relative to the remainder of the IA Defense-in-Depth model. The experiences gained from the two major DoD PKI initiatives the development and deployment of an operational FORTEZZA PKI, in support of the DMS and other FORTEZZA-enabled applications, and the

## UNCLASSIFIED

Key Management Infrastructure/Public Key Infrastructure  
IATF Release 3.1—September 2002

pilot medium assurance PKI—have been instrumental in the development of the target DoD PKI architecture.

The DoD PKI will initially support three levels of assurance, defined as Classes 3 and 4 (formerly, Medium and High) for the protection of unclassified/sensitive information, and Class 5 (for the protection of classified information on unencrypted networks). The long-term goal is to provide a Class 4 certificate to all DoD personnel and—where appropriate—Class 5 certificates via the target DoD PKI. Each assurance level has its own set of requirements for technical implementation and process controls, which becomes more rigorous as the level increases.

The target DoD PKI shall employ centralized certificate management and decentralized registration and shall use common processes and components to minimize the investment and manpower to manage and operate the PKI. The target DoD PKI also shall support a broad range of commercially based, security-enabled applications and shall provide secure interoperability with the DoD and its federal, allied, and commercial partners while minimizing overhead to and impact on operations.

The DoD PKI program continuously tracks new and evolving IETF standards to ensure that the most viable commercial standards are fully leveraged to support maximum interoperability in the future.

In addition, to ensure secure interoperability between DoD and its vendors and contractors, External Certificate Authorities (ECA) will be established using a process that ensures the required level of assurance to meet business and legal requirements. ECAs will be approved by the DoD Chief Information Officer (CIO), in coordination with the DoD Comptroller and the Office of the Secretary of Defense (OSD) General Counsel.

The DoD PKI will be implemented in a series of actions to reach the final goals. These actions are as follows:

- All DoD organizations must deploy registration applications for supporting the Class 3 (formerly Medium Assurance) PKI and the Class 4 (FORTEZZA-based) PKI.
- Protection of Category 1 mission-critical systems on unencrypted networks using Class 4 certificates and tokens.
- Protection of Category 2/3 mission-critical systems operating on unencrypted networks must use Class 3 certificates.
- Protection of Category 2/3 mission-critical systems operating on unencrypted networks must use Class 4 certificates and tokens.
- Server Authentication.
- Client identification (ID) and authentication.
- Private DoD Web servers access control software for Class 3 certificates.

## UNCLASSIFIED

Key Management Infrastructure/Public Key Infrastructure  
IATF Release 3.1—September 2002

- E-mail applications to facilitate digital signature processing of all individual messaging within DoD using Class 3 certificates.
- ID card processing software, building and facility access software, and workstation access software applications shall begin implementation for Class 4 certificates.

### Additional Information

The following sources have additional information on DoD Class 3 PKI products and services and the DoD PKI:

- Requesting Use of the DoD Pilot Medium Assurance Component of the DoD PKI (explains information and feedback to be provided to use the DoD Medium Assurance Pilot)
- DoD Medium Assurance Public Key Infrastructure (PKI) Home Page: <http://ds-2-ent.den.disa.mil/>
- U.S. DoD X.509 Certificate Policy, version 5.0, 13 December 1999; and DoD PKI Roadmap, Version 3.0, 29 October 1999.

### 8.1.7.2 FORTEZZA<sup>®</sup> PKI

The following summary highlights the FORTEZZA<sup>®</sup> PKI Solution, a solution being used by the DMS.

#### PKI Name

The PKI name is in the FORTEZZA<sup>®</sup> CMI. A CMI differs from a PKI because it includes only the CMI and the policy associated with the CMI, not the directories where the public data items are posted.

#### PKI Design and Operational Responsibility

The KMI Services and Workstation Technology division (NSA) is the Certification Authority Workstation (CAW) PMO responsible for its design, development, and testing. The Requirements and System Engineering division (NSA) and the Life-Cycle Engineering and Standards division (NSA) are responsible for CAW life-cycle support issues, such as training, installation, upgrades, and maintenance. The Electronic Key Management System Operations division (NSA) is responsible for the FORTEZZA CMI operations. Actual CAW training is accomplished via a combination of classroom, computer-based, hands-on, and on-the-job training, per policy, with the classroom training conducted by General Dynamics (CAW 3.1), Motorola (CAW 4.2.1), and Service Schools (both CAW 3.1 and 4.2.1).

Figure 8.1-15 illustrates the Policy Approving Authority (PAA), Policy Creation Authority (PCA), Indirect Certificate Revocation List Authority (ICRLA), CA, RA, and Certificate Management User Agent (CMUA). Other CMI roles not requiring dedicated workstations are the System Administrator (SA) and the Information System Security Officer (ISSO).

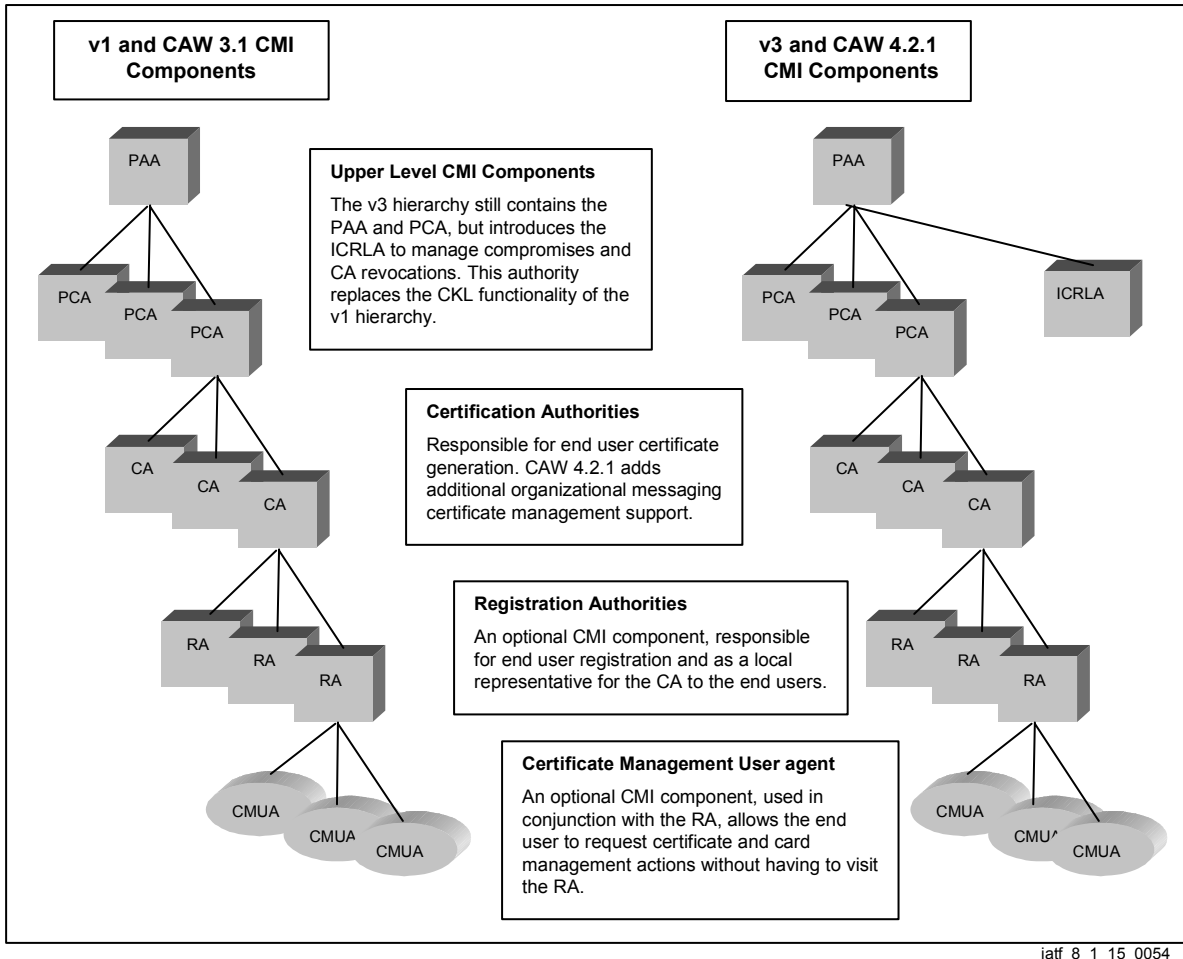

Figure 8.1-15. FORTEZZA CMI Components

## PKI Subscriber Community and Applicability

The FORTEZZA PKI was targeted and is established to address certificate and security requirements of the DoD community, but its design and capabilities are also flexible to support civilian and commercial subscribers.

For DoD subscribers, the FORTEZZA PKI operates in compliance with Class 4 assurance policy resulting from its software design/development compliance with Trusted Software Design Methodology (TSDM) guidelines, its operation on a trusted operating system designed for the B1 level, implementation of high-grade cryptographic algorithms and keys, and its strict use of hardware tokens for system infrastructure components. The certificates created and managed by

## UNCLASSIFIED

Key Management Infrastructure/Public Key Infrastructure  
IATF Release 3.1—September 2002

the FORTEZZA PKI, when teamed with compatible applications, enable subscribers to apply all of the security services—authentication and identification, confidentiality, privacy or data integrity, nonrepudiation, and access control—to unclassified and classified data. In addition, because of the high-grade cryptographic algorithms, keys, and tokens that the FORTEZZA PKI implements, it is possible for applications to provide protection (authentication and confidentiality) for information to cross-classification boundaries when such a crossing is already permitted under a system security policy (e.g., sending unclassified information through a High-Assurance Guard (HAG) from SIPRNet to NIPRNet).

DoD organizations and customers of the FORTEZZA PKI can operate CAs in their local, decentralized environment and are responsible for complying with either NAG-69C, Information Systems Security Policy and Certification Practice Statement for Certification Authorities (for X.509 v1 use with CAW 3.1 and CAW 4.2.1) or DoD Certificate Policy, Version 5.0 (for X.509 v3 use with CAW 4.2.1).

### PKI Products

The FORTEZZA PKI supports secure DoD transactions across existing national and global information networks (e.g., Internet) and allows them to be protected from threats from other subscribers of the global information network. The functionality of the current FORTEZZA PKI, based on CAW 3.1, supports the following:

- Supports U//FOUO and classified environments on the same CA platform.
- Performs trusted downgrade of information between different classification levels of network(s)/account(s).
- Creates and manages X.509 v1 certificates.
- Creates and manages v1 CRL.
- Creates and manages card, certificate, and DN in a flat file database.
- Manually posts certificates, CRLs, CKLs to X.500 DSA.
- Processes MISSI Management Protocol (MMP) messages from other networked devices.
- Implements Message Security Protocol (MSP) 3.0.
- Manages backup data for certificates, CRLS, and CKLs.

The CAW 3.1 can be configured to serve as a PAA, PCA, or CA.

The optional RA using the Motorola Registrar product, provides a cost-effective alternative to dedicated CAWs for multiple subscriber registration and routine subscriber certificate update tasks. Registrar 4.2 is available now to support not only CAW 3.1 but also CAW 4.2.1 when it is fielded.

The optional Motorola CMUA resides on subscriber Windows NT platforms and further off loads subscriber registration and maintenance functions from the Registrar. This product is available now to support CAW 3.1 and CAW 4.2.1 when it is fielded.

## PKI Future Plans and Schedule

The FORTEZZA PKI (X.509 v1 certificates only) has been operational since March 1995. The current PKI (operational since January 1998) is based on CAW 3.1. An upgrade to CAW 4.2.1 began in March 2000 for the PAA and PCAs and staggered upgrades of the CAs in the field. The March 2000 upgrade is backward compatible to CAW 3.1 functionality and its X.509 v1 certificates. The March 2000 upgrade also provides a totally new software design and code based on TSDM Level 3 guidelines, a new and improved GUI, a relational database, automatic posting of information to a public directory, management of multiple hardware and software tokens, programmable X.509 certificate extensions for flexible security policies, X.509 v3 certificates, v2 CRLS, and Indirect Certificate Revocation Lists (ICRL).

Plans are under way to develop and field a future CAW version to provide support for software FORTEZZA technology and capabilities.

## Additional Information

Additional information can be found in the following documents:

- Interim Operational Security Doctrine for the Unclassified but Controlled FORTEZZA Card, 18 February 1998.
- Interim Operational Security Doctrine for the FORTEZZA for Classified (FFC) FORTEZZA Card, June 1998.
- NAG69B, Information Systems Security Policy and Certification Practice Statement for Certification Authorities, 24 October 1997 (for X.509 v1 with CAW 3.1 and 4.2.1).
- NAG69C (replacement for NAG69B, pending final approval at NSA)(for X.509 v1 with CAW 3.1 and 4.2.1).
- DoD Certificate Policy, Version 5.0 (for X.509 v3 with CAW 4.2.1).
- FORTEZZA Public Key Infrastructure (PKI) Concept of Operations (CONOPS), Version 1.8, 7 January 2000.
- Certificate Management Infrastructure (CMI) Transition Plan, Version 2.0, 23 November 1999.

### 8.1.7.3 DoD Target Key Management Infrastructure

Throughout the following text, KMI is used interchangeably with KMI/PKI.

### 8.1.7.3.1 Background

The people, programs, and systems that carry out or support the broad range of DoD missions perform a variety of activities. These diverse activities, depicted in Figure 8.1-16, represent an ever-expanding need and role for IA capabilities in DoD operations. Traditionally, DoD has addressed these needs with stand-alone cryptographic components. In today's IT-rich environment, DoD's IA needs are being addressed with security features integrated into the many communications and information processing system components used by the DoD. These include workstations, guards, firewalls, routers, in-line network encryptors, software applications, and trusted database servers. The deployment of the large numbers of these security-enabled components (both traditional cryptographic devices and integrated IA features) is placing an increasing burden on the network infrastructure that provides KMI products and services.

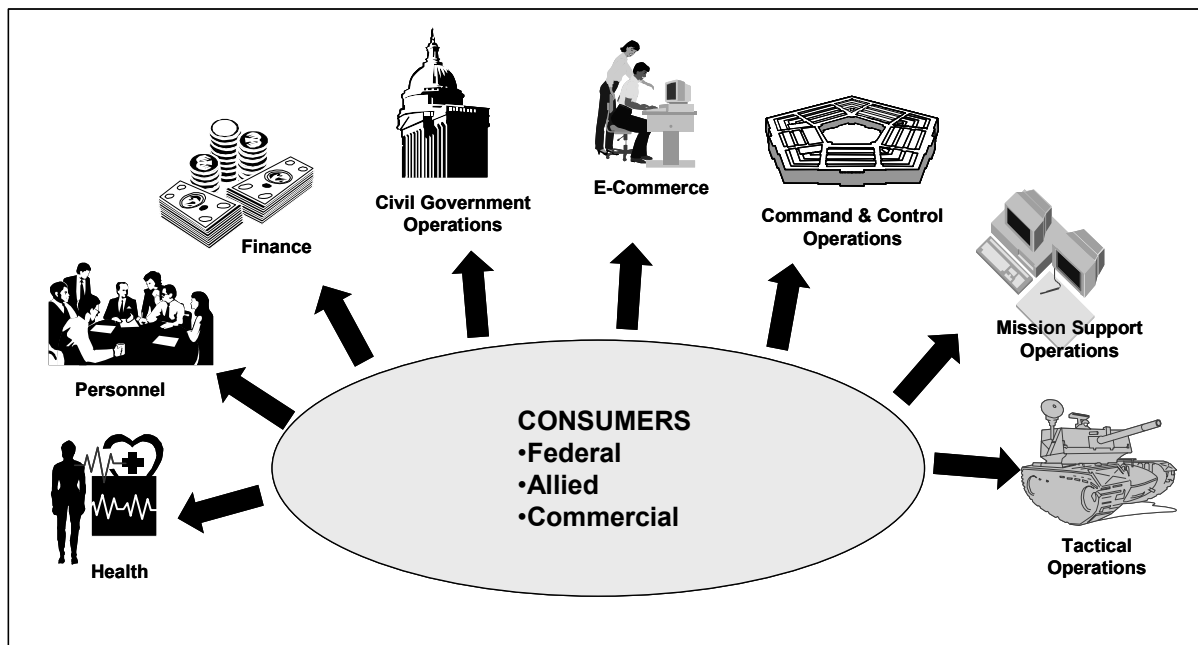

iatf\_8\_1\_16\_0055

Figure 8.1-16. Operational Activities Supported by the KMI

The DoD KMI is a foundational element for a secure IA posture in the Defense Information Infrastructure (DII) and the broader national security community. The DoD is taking an aggressive approach in acquiring a KMI that meets the requirements for all IA key management needs. The DoD KMI program, supported by the services and agencies, Joint Staff, and DoD contractor community, is addressing this critical need.

The state of the current key management systems creates compelling reasons for modernizing the DoD KMI.

- **Infrastructure of Independent Stovepipes.** The current key management environment is composed of separate and independent infrastructures that provide and manage their

## UNCLASSIFIED

Key Management Infrastructure/Public Key Infrastructure  
IATF Release 3.1—September 2002

own set of security products. These systems will become increasingly cumbersome and costly as new technology and their attendant security solutions continue to advance and the resources needed to operate them decline. This key management environment is composed of several unique solutions built for specific product lines. Although the solutions satisfy unique security needs, they each require different tools and training to obtain their respective products and services, imposing an unwarranted strain on resources.

- **Inefficient Expansion of New Capabilities.** Adding new key management capabilities has frequently required integrating new capabilities into existing systems that were not designed to perform the new functions, or creating new, independent systems to provide the needed support. One recent example is the deployment of a totally separate (stovepipe) network infrastructure to support DoD's use of PKI-based security products. Although this is an example of the limitations of the existing KMI structure, other programs are running into the same issues. This is impeding DoD's ability to respond to new requirements and demanding more resources for supplying cryptographic key products to support its missions.
- **Common Functions and Operations.** Although created independently, the existing systems contain many common threads (e.g., registration, ordering, and distribution) that could logically be combined and offered as a unified set of processes. The key management community and DoD Joint Staff have recognized this fact. They have identified a unified KMI as a critical system infrastructure that is needed to support key and certificate management approaches for mission-critical, logistic, and administrative systems.
- **Opportunities for Applying New Technologies.** Several KMI systems that have existed for a number of years are in need of an upgrade to take advantage of modern communication technology. This technology area has advanced significantly in recent years, providing the marketplace with many new and worthwhile, applicable techniques that would greatly improve efficiency and performance.

Given the critical importance of key management, applying modern technology within a sound IA systems approach is imperative. The KMI initiative focuses on unifying the disparate key management systems within a single, modern architecture—one that is modular, flexible, and extensible and will eliminate redundant resources associated with operation, maintenance, and training, resulting in substantial cost savings.

Commercial security technology using public key cryptography for U//FOUO requirements is rapidly becoming the largest “application class” that must be supported by the DoD KMI. However, requirements for support of classified applications are also projected to continue to grow significantly as new classified solutions such as secure wireless and Global Positioning System modernization are implemented. This creates the need for a more encompassing key management paradigm. The KMI will enhance the DoD's capability to support these mission-critical requirements. The DoD KMI program will unify these many disparate key management systems within a single, modern framework, introduce additional key management capabilities to



## UNCLASSIFIED

Key Management Infrastructure/Public Key Infrastructure  
IATF Release 3.1—September 2002

support the continued expansion of KMI services that are projected, and address the Congressional mandate to reduce operational costs associated with the KMI.

### KMI Products and Services

KMI, as described herein, refers to the framework and services that provide registration, enrollment, generation, production, distribution, control, and tracking of the broad range of KMI products needed by the DoD. A critical challenge for the KMI will be to provide continuing support for existing products and services and for emerging security solutions. At a minimum, the following product categories will be supported:

- Human-readable cryptographic products (e.g., code books, one-time pads, authenticators, and key lists).
- Symmetric cryptographic key for point-to-point and net use and for use in wireless products.
- DoD Class 3 PKI Root CA.
- Asymmetric cryptographic products.
- Electronic certificates (e.g., signature, attribute, and key exchange) used in a multitude of applications to implement security functions such as I&A, access control, integrity, confidentiality, and nonrepudiation.
- Key management documentation (e.g., policy documents, equipment operator manuals, and specifications) needed in support of the cryptographic user community.

The Target KMI provides the framework and services that unify the secure creation, distribution, and management of these products. The DoD KMI will enable the provisioning of these services for military, intelligence, allied government, contractor, and business customers. A baseline set of key management services offered by the KMI to support the user community includes the following:

- **Registration**—Identifying, in an authenticated manner, individuals, or system entities (either internal or external to the KMI) and their related attributes.
- **Enrollment**—Authenticating the establishment, modification, and deletion of privileges for individuals, system entities, or organizations.
- **Ordering**—Requesting cryptographic product (e.g., keying material, certificates, and manuals) to support a security application.
- **Generation**—Generating cryptographic products (e.g., symmetric key, asymmetric key and/or a public key certificate) by a security infrastructure element.
- **Distribution**—Providing physical and electronic products, including rekey, to the user in a secure, authenticated manner.

## UNCLASSIFIED

Key Management Infrastructure/Public Key Infrastructure  
IATF Release 3.1—September 2002

- **Policy Management**—Managing and enforcing policy and procedures for operating the KMI in a trusted and secure manner.
- **Trust Extension**—Reviewing and ruling on issues of cross-certification or bridging with other key management infrastructures.
- **Archiving**—Providing for long-time storage and retrieval of important data that may not be immediately accessible to online users of the system.
- **Accounting**—Tracking the location and status of cryptographic products.
- **Key Recovery**—Recovering encrypted information when the intended decryption key is unavailable.
- **Compromise Management**—Providing notification of compromised keys and invalid certificates in a timely and authenticated manner.
- **Audit**—Supporting periodic security evaluation of KMI operations.
- **Library**—Providing access to key management reference documents and information.
- **Destruction**—Destroying certificates and keying material.

### Planned Evolution

The DoD KMI will be implemented as a series of evolutionary phases culminating in a re-designed, unified architecture. Strategic and architecture planning will require indepth coordination with KMI government and commercial partners. Every 18 to 24 months, a new Capability Increment (CI) will be delivered to operational users taking into account new and updated user operational, security, policy, and technology requirements, and programmatic opportunities. Timing of the capability increments is critical to ensure optimum synergy and cohesion with the individual systems in the DoD KMI architecture. For each CI, the Target KMI will be redefined to be consistent with current and projected operational/security needs and technology advances. The updated Target KMI definition will be used for programming and budget planning for the products and services needed to realize the Target KMI. This approach requires sustaining system engineering and development resources, and wide service/agency/organization support for the acquisition, deployment, and operations of each CI.

The KMI uses a wide variety of existing networks and workstations to fulfill its mission and is being designed to implement as many KMI-wide functions as possible on COTS platforms. Initial deployments of the KMI will be structured as separate KMI functions for each security classification domain. However, as the system evolves, it will transition to a structure that allows the transfer of appropriate data between domains. Using this approach, most KMI functions will operate on a single-level (commercial) system-high platform at client manager nodes and in the centralized portions of the system infrastructure.

## Goals and Objectives

A number of goals have been identified for the KMI based on user community input security, advancing technology and the reality of a shrinking budget. These goals are as follows:

- **Transparency.** Although some functions within the KMI inherently require direct operator or user interaction, the KMI will automate as many operations as possible. KMI-aware devices will interact with the KMI, transparent to the user.<sup>1</sup> Current, manpower-intensive operations (including accounting and archiving) will be automated and transparent to KMI users.
- **Ease of Operation.** The Target KMI will provide simplified, intuitive, and consistent interfaces for users to obtain KMI support for the ever-increasing range of PK functions. Users will have standard Web browser access to the KMI—with screens tailored based on their identity, role (and authorized capabilities), and KMI products and services tightly integrated into their mission planning and system management capabilities.<sup>2</sup>
- **Access to Needed Information.** The KMI will offer direct, online access on all relevant policy information and to operational information (e.g., inventories of keying materials and cryptographic devices) to ensure that policies are carried out appropriately. Customer support will be provided 24 hours a day, 7 days a week to assist users with KMI-related issues.
- **Reduction in User Manpower Support Needs.** Continued proliferation of cryptographic devices (user terminals, network servers, security-enabled network devices) and projected wide-scale deployments of PKI-enabled software applications will continue to increase user manpower burdens to obtain KMI products. The Target KMI will reduce this burden with its greater use of commercial standards and products.
- **Responsive Policies and Doctrine.** Uniform, national level, and DoD-wide policies, doctrine, practices, and procedures will be established in joint-community forums to ensure interoperability and consistency of joint operations at the organizational level. They will be coordinated and issued before deployment of cryptographic equipment.
- **More Efficient Use of KMI Operator (Internal) Support Needs.** Continued proliferation of cryptographic devices (user terminals, network servers, security-enabled network devices) and projected wide-scale deployments of PKI-enabled software applications will continue to increase demands on KMI operator manpower needed to generate and produce KMI products. The Target KMI will be more efficient than the existing KMI, allowing them to deliver products faster and respond more quickly to new requirements.
- **Enhanced Security.** Delivery of all orders will be available securely and directly to the end-user or end-user devices that require them. The KMI will be built on authentic,

---

<sup>1</sup> Although the KMI can provide secure infrastructure capabilities to enable this transparency, modifications to KMI-aware devices are also required to add functionality that can realize this transparency.

<sup>2</sup> Similarly, this goal can be realized only with enhancements to mission planning and system management components.

universally accepted identities for all users, operators, and devices. Standard tools and tool kits will be provided by the KMI to ensure that all KMI-relevant operations (e.g., key exchange, rekeying, and certificate path validation) are performed correctly.

## General Features of the Target KMI

Several pervasive characteristics of the Target KMI exist:

- **Modularity.** The Target KMI, although still being refined, is based on a modular structure that will enable adequate flexibility to ensure that it can evolve over time. It will immediately leverage existing key management system capabilities and commercial components (e.g., commercial certificate authority workstations, directory systems) in the baseline implementation and incrementally evolve the capability as commercial technology matures. The KMI capabilities will evolve, taking advantage of commercial technologies; a strategy that requires a DoD enterprisewide standards approach, and a coordinated process within DoD to influence the direction of commercial standards bodies to incorporate features important to the DoD.
- **Automated Service.** The KMI will offer a well-defined set of KMI products and services, with an established set of delivery mechanisms and interface standards for “last-mile delivery devices,” clearly defining how KMI products will be delivered.
- **Key Delivered Directly to End-Devices.** The KMI will evolve toward the electronic delivery of key, with delivery directly to end-devices. The KMI will provide tool kits that can be used to KMI-enable devices and operational support systems to take full advantage of the advanced features and capabilities that the KMI will offer.
- **Common Management Functions.** The KMI will introduce a set of common management functions that will enable consistent KMI operations provided by the various existing stovepipe KMI systems. It will augment these with a set of primary services (e.g., registration, common ordering, and key recovery) that will enable common KMI interactions for users and KMI-aware devices to obtain the specific KMI products or services they require. It will also incorporate functional and physical modularity to facilitate an orderly introduction and enhancement of operational capabilities throughout the KMI’s life cycle.
- **Online Customer Support and Library Access.** The KMI will include an online repository to provide authorized KMI users and managers with a complete catalog of KMI products and services, test results of commercial IA products, electronic versions of current policies, manuals, advisories, and inventory status for deployed KMI-relevant devices and KMI products (including those of allies and coalition partners).
- **Leveraging Existing KMI System Investments.** The KMI encompasses products and services provided by the Electronic Key Management System (EKMS) physical key management capabilities and operational PKI capabilities. These provide a wide range of cryptographic keys for traditional symmetric key systems and key pairs and certificates for public key systems. The Target KMI provides the framework and services that will

allow DoD to incorporate the existing KMI systems into the Target, thus improving the existing underlying system infrastructure that provides security services to military, intelligence, allied government, contractor, and business customers.

- **National Level Policies.** DoD faces many KMI challenges. It is anticipated that the implementation of DoD KMI will result in changes to areas such as national cryptographic policy to better coordinate the handling of classified and nonclassified key management data.

## System Context

The KMI interacts with numerous external components and systems to perform its intended functions. Figure 8.1-17 illustrates the KMI system capability. A primary capability is to interact with the users it is intended to serve. The KMI must also interact with external federal and commercial KMIs and PKIs. It interfaces to external data sources, including local user community repositories and external data sources such as the Defense Eligibility and Enrollment Reporting System (DEERS) database. The DEERS database contains personnel information that may be accessed during registration of some end users.

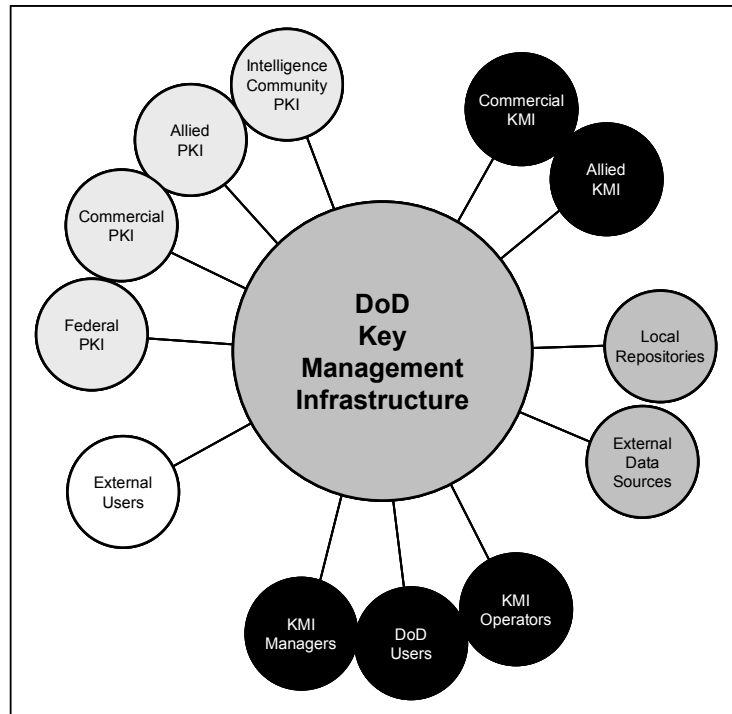

iatf\_8\_1\_17\_0056

Figure 8.1-17. DoD KMI System Context

### 8.1.7.3.2 DoD KMI System Context KMI Nodal Architecture

The Target KMI architecture consists of four types of functional nodes, as shown in Figure 8.1-18. Their interconnectivity and summary of the major functions of each node is included in the figure, and discussed in detail below. Section 8.1.7.7 identifies the major documents that describe the Target KMI in detail.

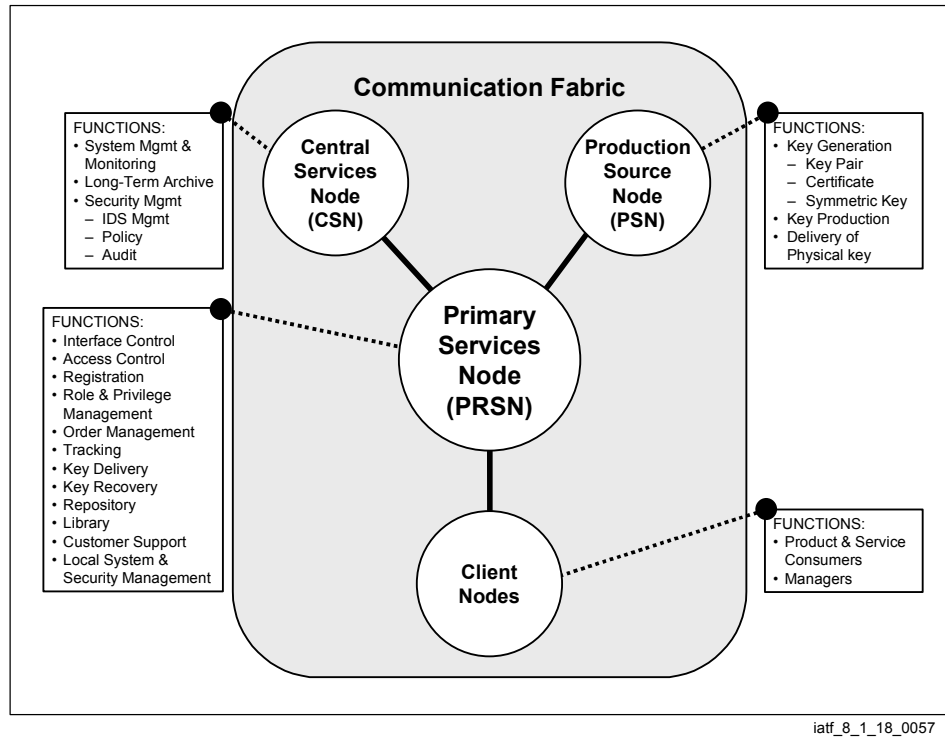

Figure 8.1-18. Nodal View of the Target KMI

## Client Nodes

The client nodes represent the consumers of KMI/PKI products and services and the workstations that support the various KMI/PKI managers. Figure 8.1-19 provides a breakdown of several generic types of clients. Client nodes, also referred to as end entities, include stand-alone cryptographic devices, devices that incorporate security features that rely on key management services (e.g., security features within a router), and workstations that use software applications that require KMI support.

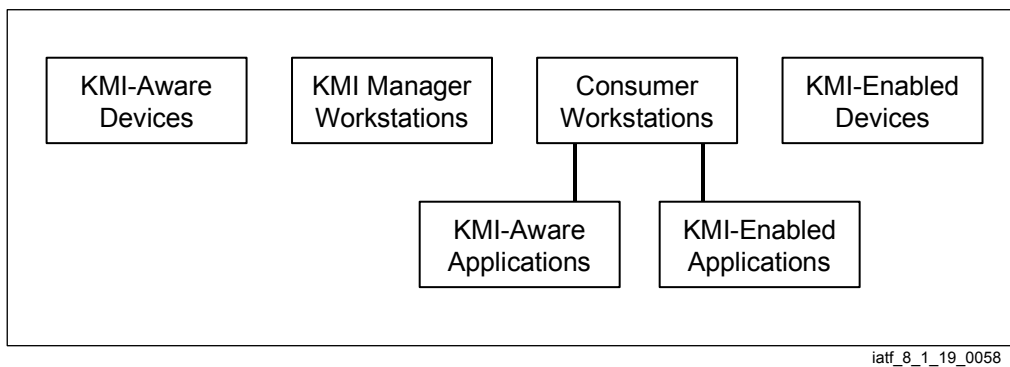

Figure 8.1-19. Breakdown of Client Nodes

## Primary Services Node

KMI users—whether they are humans, devices, or applications—obtain their products and services from a Primary Services Node (PRSN). The PRSN provides common management functions in a server-based architecture and provides its required services in multiple classification domains. The PRSN provides to the client node components, unified and transparent access to all of the different production sources and delivery of KMI products and services to consuming applications, directly or through an intermediary. As implied in Figure 8.1-19, the PRSN is also the node that handles user access. When KMI products are requested, the PRSN will forward the request to the appropriate Production Source Node (PSN) for generation and production. If the product can be delivered electronically, the PRSN will forward it on to the client node.

## Production Source Node

The PSN are responsible for the generation and production of KMI products. These products will be created at the request of PRSNs. If a physical product is needed, the PSN is responsible for delivering the product directly to the client node. PSNs are separated from the common management functions of the PRSN, but interface via available communications networks to the management infrastructure provided by the PRSN. The EKMS Central Facility and Key Processor (KP), the existing physical systems, and the PKI CA are examples of current KMI systems that provide functionality associated with a PSN. The Target KMI architecture has adopted a modular structure specifically to accommodate the modification of existing, or addition of new production sources.

## Central Services Node

The Central Services Node (CSN) provides overall system management and monitoring functions for the system infrastructure. In the Target KMI, the CSN will provide the long-term system archive and the master KMI database, and will replicate data to the individual security enclaves of the PRSNs. The CSN will also handle overall system infrastructure security management, including IDS oversight, audit data collection and analysis, long-term archiving, policy management, and system health monitoring.

## General Deployment Considerations

The Target KMI will be deployed as modular sites consistent with the nodal architecture discussed above. There will be one CSN and a physically isolated hot backup to mitigate risks of natural disasters interrupting operation. Several PRSN will be sites in strategic locations across the Continental United States (CONUS).

Each will be capable of serving as a backup capability to other PRSNs, with automated cutover capabilities available to ensure uninterrupted service to KMI clients. Deployable versions of PRSNs will be established in sites outside CONUS to minimize network connectivity issues for operations in various theaters. Typically, these sites will reach back to the CSN and PSN located

in CONUS. To the extent that PSN capabilities are needed to support these deployed sites, a black PSN will be available to provide the capability (using stored materials that can be transferred via physically and/or electronically protected means), minimizing the risks of operating in potentially hostile environments. The deployed PRSNs will also include basic CSN provisions to facilitate operations when connectivity back to CONUS is impaired or unavailable.

The KMI will use the communication channels already serving its customers in other capacities. The KMI will rely on existing communications paths for connectivity within the system. The KMI will also support dialing capability through secure terminal equipment. Once connections are established, the interfaces and functionality will be the same as that available when connecting to the KMI through a data network.

### **8.1.7.3.3 Perspectives on KMI Operations— An External KMI Perspective**

This section provides an operational overview of major Target KMI functions from the perspective of users and managers of KMI products and services. Further detailed descriptions of these operations can be found in the Target KMI Concept of Operations Document.

The Target KMI is designed to automate operations to the extent that it is feasible and prudent. For those operations requiring human intervention, the KMI provides standard operating procedures for a range of user and manager functions (referred to as common management functions). KMI user and manager operations will be performed as local client workstations interacting with server capabilities in the PRSN. In general, a KMI user or manager will insert their KMI token into their workstation, log into the PRSN, request a particular KMI function, and be connected to the appropriate server.<sup>3</sup> Where feasible, the PRSN will provide intuitive screens with pull down menus tailored to the specific role(s) and privileges of the requester.

## **Registration**

Registration is the process that allows an end entity to become *known* to the KMI. It establishes the identity of the end entity that the KMI asserts for all of its operations. Registration also results in the generation of an identity certificate and the creation of a token that is delivered to, and remains in the possession of, the registrant. KMI registration is a decentralized process that is performed by a number of Registration Managers (RM), including RAs and LRAs. Within the context of the Target KMI architecture, the RM is a client node manager and is typically someone who is located close to the user.

The DoD PKI Certificate Policy (CP) establishes the requirements and policies that are used during registration. In a typical scenario, a registrant appears in person before an RM and presents credentials of his or her identity as required by the appropriate CP and CPS. To register devices, the device sponsor or component administrator submits appropriate documentation about the device to their LRA. The RM logs into the PRSN using a KMI token to establish

---

<sup>3</sup> Although reference is made to specific “server,” in actuality it represents functional capabilities of the KMI node referenced.



## UNCLASSIFIED

Key Management Infrastructure/Public Key Infrastructure  
IATF Release 3.1—September 2002

privileges and accesses the registration server. The RM validates that the information provided by the individual agrees with independent identity data obtained from an independent external data repository (e.g., DEERS database or a repository provided by the department, agency, or organization).

### **Enrollment**

Enrollment is the association of privileges with an individual's KMI identity by a KMI Privilege Manager (PM). Enrollment enables KMI users and managers to conduct transactions for which they have been granted privileges. Each KMI operator and each client node manager has a defined role (or set of roles) in the KMI, and roles determine the scope of privileges within the security infrastructure. For example, the role of an RM, like an LRA, is to register users in the system. Other managers, such as user representatives or product requesters, may order keys, certificates, or other services from the KMI on behalf of registered users. A PM performs the function of defining roles, allocating privileges to those roles, and assigning roles to individual managers.

### **Request and Tracking**

The process of requesting KMI products and services and then tracking the status of those requests is structured in a manner similar to registration and enrollment. Provisions are also included for direct requests to be made from KMI-aware devices that have been configured to perform KMI transactions transparent to users and operators. An authorized KMI end entity inserts a KMI token into the workstation and accesses the PRSN Common Ordering Manager. KMI and entities may choose to access a catalog of all online KMI product and services offerings in the KMI library. They also are offered a menu of templates for each KMI service and product for which they have been assigned a privilege. The templates are tailored to limit selection to only those options to which they have been granted privileges. They can either retrieve an existing request through the template and modify the data for resubmission or access a blank template. Once the request is completed, they submit it to the PRSN.

Tracking orders is performed in a similar manner. Each order is given a tracking number that can be referenced. An authorized operator can access a list of all pending orders. They can choose to query for status, update, or cancel a request. They also can choose to remain online while the status is requested, or select to have the PRSN send a notification of the action when it is available.

### **Distribution**

This process arranges for the transfer of KMI products from the KMI to end users or intermediaries in a secure and authenticated manner. Two basic types of KMI products are distributed. The first type includes physical products (e.g., hard copy codebooks, canisters of hard copy key materials, and tokens). These are distributed through protected shipping channels (e.g., the Defense Courier System). A goal of the Target KMI is to reduce the amount of these materials to the extent operationally acceptable. The preferred means of distribution is protected

electronic delivery. When a KMI product is available for distribution, it can be “pushed” automatically to the intended recipient. The PRSN includes an electronic vault for intermediate storage of black KMI products that have been generated previously. The KMI provides a capability for authorized users to “pull” materials from the vault. The vault also serves as a rapid access source for products that the KMI will deliver (or “push”) to end entities.

## Key Recovery

Key recovery capabilities allow a means for authorized KMI users to access KMI products associated with an encryption process (e.g., KRI) in the event that key is lost or otherwise unavailable. Two general applications exist for key recovery. One application is to enable local information owners to access information that is protected when a key is lost. The other is a central capability to provide KRI to other authorized individuals based on national policies for key recovery.

## Revocation

Revocation is used in normal operations as individual responsibilities and privileges change, resulting in the need to invalidate individuals’ KMI roles and privileges. It is also a critical component of recovery in the event that sensitive KMI materials of an individual, a KMI manager, or an internal KMI operation have been or are suspected of being compromised. The process for requesting a revocation is performed in the same manner as KMI product and service ordering. An authorized KMI manager inserts a KMI token into the workstation and logs into the PRSN. The KMI manager’s workstation will access the Compromise Recovery Agent within the PRSN, which will validate the manager’s identity and the role and privileges associated with that identity. The KMI manager is also offered a menu of intuitive templates to allow a revocation request to be accomplished. The templates are tailored to limit selection to only those options that they have been granted privileges. The KMI processes that request, and activates mechanisms automatically to prevent any operations using the revoked KMI materials.

### 8.1.7.3.4 System Operations— An Internal KMI Perspective

Although the previous section highlighted critical KMI system operations from the perspective of KMI users and managers, this section provides an overview of the internal operations of the Target KMI to support system functions. The KMI is designed to provide a set of common management functions to provide a uniform, consistent, and intuitive interface to KMI users and managers.

KMI manager and end-user workstations are structured as “light clients,” using commercial Web technologies to support transactions with servers provided in the PRSN. This allows system enhancements to focus on updates to these servers, minimizing reconfiguration of RM software. From the perspective of the KMI internal operations, the KMI end entity uses a workstation and KMI token to access the PRSN. The connection is secured using the token as a basis for establishing identity and securing the transactions. The PRSN Access Manager validates the end

## UNCLASSIFIED

Key Management Infrastructure/Public Key Infrastructure  
IATF Release 3.1—September 2002

entity's identity, role(s), and privileges before access is granted to any other KMI resources. For all operations, each server within the KMI will verify the privileges for the identity represented in the token and whenever feasible will provide tailored screens with pull-down menus for the entity to select any authorized operation desired. Archiving of audit information for all interactions will be maintained automatically by the PRSN. Tools will be available to allow authorized users and managers to query the audit information.

### Registration

Registration by its nature requires involvement of users and operators. Registration allows an individual or device to receive a PKI identity. The RM accesses the PRSN and logs into the Registration Server. Using screen menus tailored for registration of the type of entity being registered, the RM enters the required identity information. The workstation, via the PRSN, accesses the external repository for information to be validated. It presents this information to the RM, annotating possible discrepancies. Once the RM accepts the identity as valid, the workstation develops an identity certificate.

Several concepts are still being considered for processes at this point. The scheme currently used is for the token to generate a public and private key pair. Other options are for the end user workstation or the CA to generate the pair. When the token generates the pair, the token transfers the public component to the RM workstation that, in turn, forwards it along with a certificate request through a PRSN for registration to a PKI CA PSN.<sup>4</sup> The PRSN assigns a KMI unique identifier to the identity. The CA creates and signs an identity certificate, updates the appropriate directory, and returns the certificate to the RM workstation. The RM workstation loads the certificate onto a token and the RM issues the token to the user. All tracking and audit information is performed automatically by the PRSN and CA PSN, as appropriate.

### Enrollment

Using a KMI token to establish identity, the PM accesses the PRSN and logs into the PRSN Enrollment Server. Enrollment allows an individual or device to receive encryption keys. The PM then inserts the token for the end entity being assigned KMI roles and privileges. The Enrollment Server provides menu screens for the PM to select the operations desired. This includes the update of role definitions, privilege assignments to roles, and identities assigned to roles. All PM interactions will be automated and updated into the KMI library repository that stores enrollment status information.

### Request and Tracking

An authorized KMI user or manager can access the PRSN and log into the Common Ordering Manager to request KMI products and services and to obtain status of requests that are being processed. The Common Ordering Manager will provide tailored, intuitive screens and will be validated against known data domains of the template and privileges of the product requestor.

---

<sup>4</sup> In selected operations, the private key is transferred in a secure manner to the CA (via the PRSN) to support future key recovery operations. Private keys associated with identity certificates are NOT escrowed.

Feedback to users is provided online if those checks find discrepancies before a request is accepted. The same basic sequence is used to cancel or update orders. When a valid request has been submitted, the Common Ordering Manager assigns an internal order tracking number and prepares an electronic order request.

KMI-aware devices incorporate capabilities to automatically and directly interact with the Target KMI. In this regard, they can initiate KMI requests automatically, interacting with the PRSN Device Ordering Manager function in a manner similar to the process used by authorized KMI users and managers. They will have to be registered as a valid end-entities and enrolled to authorize appropriate KMI privileges. Because there is no operator in the loop, they will not go through screens; rather they will generate requests in an automated manner. Orders from devices will be tracked in a standard manner so that device sponsor or component administrator can query status and intercede to update or cancel orders generated by devices under their purview.

## **KMI Product Generation**

All KMI products will be generated within a PSN in response to order requests from a PRSN. These can result from product requests from KMI managers, directly from KMI-aware devices, or from event services. PSNs produce all physical KMI products. For electronic products, PSNs will provide only Black materials. The PSN will perform all cryptographic functions necessary to generate KMI products, to protect them while being processed and stored within the PRSN, and for distribution directly to an end entity or through an intermediary (such as a Communications Security [COMSEC] Custodian).

## **Delivery**

PSNs arrange for delivery of all physical KMI products through proper physical distribution systems. However, the preferred distribution for KMI products is via Black electronic transfers. The Target KMI is structured to enable delivery directly to end entities, including KMI-aware devices that can interact automatically with the KMI. This presumes that the KMI-aware devices include appropriate protocols to facilitate the transfers and internal cryptographic processing.

As discussed earlier, the PRSN Delivery Agent server can push products, automatically initiating an electronic transfer of Black KMI products over a secure link to a designated recipient. Authorized recipients can access the PRSN and log into the Delivery Agent server to “pull” KMI products. The Delivery Agent establishes a secure link with the intended recipient and electronically transfers the Black KMI products over that link. PSNs include a capability for an electronic vault, providing a repository for previously generated and encrypted products, each with a unique identifier, split into a nonsensitive portion that is stored, and a sensitive portion that is encrypted. The PRSN is capable of querying to determine the status of materials that are stored, deleting stored materials, and retrieving them. If KMI products have to be decrypted (e.g., to make additional copies that can be prepared for delivery to multiple end entities), to facilitate delivery, the products are transferred back to a PSN for additional processing, and the requisite Black products are returned to the vault.

## Key Recovery

The KMI Key Recovery Agent capability will collect and archive all KMI information that may be needed to support key recovery operations. KRI will be encapsulated in a manner to require multiple approved KRAs to collaborate to gain access the sensitive KRI. The encapsulation will enforce protection and access controls resultant KRI as dictated by appropriate national policies (e.g., two or more pre-selected individuals will need to be involved to gain access to the unprotected KRI materials.) When KRI is accessed, it will be protected to prevent inadvertent disclosure and transferred onto a KMI token for delivery.

## Revocation

Revocation of KMI privileges is accommodated by modification or deletion of roles and privileges as addressed under enrollment. The KMI will be able to revoke any KMI product. Each product will have a unique identifier (e.g., Certificate Number, Key Identifier). Authorized KMI managers can access the PRSN and log onto the Compromise Recovery Agent capability to process requests for revoking KMI products. When a validated request has been processed, the Compromise Recovery Agent will task an appropriate PSN to add the identified KMI materials to an appropriate mechanism to enforce the revocation.

The Target KMI will support two approaches for enforcing revocation. For certificate-based transactions, the KMI will integrate Online Certificate Status Protocol (OCSP) into their online validation servers. These servers provide worldwide distribution and access to information needed to ensure that only valid keys and certificates are being used. Protocols within KMI-enabled and KMI-aware applications and devices may include verification using these servers to show KMI materials at both ends of the transactions are valid. The Target KMI will also support the use of Compromise Recovery Lists, including CRLs and CKLs as other mechanisms. These support other than certificate-based operations and are for use in situations in which ready access to distributed, online servers is not operationally feasible (either based on mission constraints ala tactical environments) or at times when network access is limited or unavailable (e.g., network outages).

## System Management

Each KMI site has provisions for a site manager to perform a number of critical operations. A primary responsibility of these managers is to manage the day-to-day operations of the site. The site manager is responsible for monitoring the performance of the overall site, and when necessary off-loading operations to another site as a backup capability. This includes a variety of tasks such as starting up, backing up, aborting, and restoring site operations. Other critical responsibilities are related to managing the security of the site, including operating intrusion detection systems (IDS), providing local site responses to intrusions, managing local security audits, sanitizing the site, and returning the site to a secure state. Site managers are responsible for coordinating the installation, testing, maintenance, configuration, and control of all components within the site.

The CSN is also responsible for managing the overall KMI. In addition to its own site management, it provides long-term archive capabilities, performs audits, provides help desk

capabilities, and enforces and verifies the compliance of operations with established security policies. The CSN is also responsible for managing all KMI IDS reporting, analyzing the aggregated information, and formulating and coordinating responses to suspected and actual cyber attacks.

Each PRSN site has several subsystems that provide databases and data management services for the enclave. For example, each site will maintain the appropriate product catalog, registration data, and role and privilege data for clients that request products and services at that site. Each PRSN will also serve as a hot standby (backup) capability for other PRSNs and will have the capability for automated transfer of services to and from other PRSNs. Each PRSN also maintains a library of documents that can be downloaded by client node components and software modules that may be run by clients that access the PRSN.

The PSNs also have system management responsibilities unique to their sites. As production nodes, they have to plan and schedule production activities (based on historical demand statistics and customer demand projections), monitor production flows, and allocate production resources to best satisfy production demands. To support tracing and status reporting of orders, the PSNs perform accounting and tracking of all orders from time of order receipt—through each production stage—until transfer of Black materials back to the PRSN or delivery of physical products directly to recipients. Because the PSNs process sensitive KMI product materials, they will have to maintain archive capabilities to augment those in the centralized long-term CSN archive, tools to facilitate appropriate audits, and facilities and procedures to comply with KMI security policies.

### **8.1.7.3.5 Transition**

Although the actual KMI structure will evolve over time, the KMI program has established a fundamental philosophy for transition. Enhanced system capabilities will be introduced in parallel with existing operational capabilities. The strategy will be based on NO HARD CUTOVER whenever feasible. This will allow users to plan and implement effective transition of their operations to take advantage of new capabilities. Legacy capabilities will be dismantled only after a complete operational transition has been accomplished.

### **Impact of Transition on KMI Clients**

Transition from the present systems to the Target KMI and the interim transitions from one KMI CI to another are planned and will be executed to minimize the impact on KMI managers and users. The Target KMI architecture itself has been designed to be consistent with this tenet. One example is the use of a “light client” concept to allow KMI manager workstations to remain stable, with enhancements being introduced in the servers typically provided in PRSNs. Another example is the use of validation servers to perform security-critical certificate path validation and enforcement of compromise recovery as a means for providing a more stable environment for client applications.

The PKI capabilities plan to follow this to the fullest extent feasible. The adoption of commercial industry standards and trends will maximize the use of commercially available

## UNCLASSIFIED

Key Management Infrastructure/Public Key Infrastructure  
IATF Release 3.1—September 2002

applications. Reliance on commercial PKI tool kits for enabling of DoD custom applications will ease PKI-enabling. However, commitment to commercial industry standards implies that custom DoD applications may have to be upgraded to follow the commercial sector's evolution. If custom applications incorporate special features to support DoD-unique requirements, the diversity of COTS and GOTS systems can create significant issues.

Broader KMI capabilities will also continue to evolve. However, the KMI will maintain its full complement of products and services, and introduce new capabilities as additions rather than replacements. As discussed above, KMI products and services will be dismantled only when the community no longer requires them. KMI tool kits will evolve to ensure backward compatibility and interoperability with the newest features of the KMI. KMI device owners, developers, and providers will have the opportunity to retain current operational configurations or take advantage of KMI advanced features, as they become available. The KMI's longer range capability increment rollout planning enables device developers to plan their products' evolution in an organized and efficient manner.

### **8.1.7.4 U.S. Federal Public Key Infrastructure**

The Federal PKI is headed by the Federal PKI Steering Committee (SC), which is composed of representatives from all federal agencies either using or considering the use of interoperable public key technology in support of electronic transactions. The Federal PKI SC is chartered under the Enterprise Interoperability and Emerging Information Technology Committee of the U.S. Federal Government CIO Council. It also has strong ties to the Security, Privacy, and Critical Infrastructure Committee. It provides guidance to federal agencies and executive agents regarding the establishment of a Federal PKI and the associated services.

The Federal PKI SC also receives recommendations from the Federal PKI Technical Working Group (TWG), which responds to issues presented to it by the Federal PKI SC relating to the technical implications of developing the PKI.

The Federal PKI will support secure Federal Government use of information resources and the National Information Infrastructure (NII). The Federal PKI will establish the facilities, specifications, and policies needed by federal departments and agencies to use public key based certificates for information system security, electronic commerce, and secure communications.

The Federal PKI will support secure communications and commerce among federal agencies; branches of the Federal Government, state, and local governments; business and the public. The Federal PKI will facilitate secure communications and information processing for unclassified applications.

The Federal PKI will be created largely from the bottom up. Federal efforts to use public key cryptography begin with individual applications within agencies that provide immediate support for vital agency programs. These implementations are paid for largely out of program funds, not funded as a centralized Government PKI.

The core Federal PKI consists of CAs, RAs, certificate status responders, and management authorities that manage public key certificates used by federal departments and agencies for unclassified application.

PKI clients will use the public key certificates issued and managed by the PKI to provide security services to federal users, such as key pair generation, digital signature generation, digital signature verification, and confidentiality key management.

The Federal PKI is fielding a BCA that provides certification paths between CAs in agencies and outside the Government. Federal CAs that meet the requirements of the Federal Bridge Certificate Policy will be eligible to cross-certify with the BCA, thereby gaining the certification paths needed for broad trust interoperability in the larger federal and national PKI. Certificates issued to and from the Federal BCA will normally include certificate policy mapping extensions that allow relying parties to establish that remote certificate policies are equivalent to local ones. The Federal BCA operates under the control of the Federal PKI Steering Group, which is the Certificate Policy Authority for the Federal Government. Establishing policy mapping equivalencies is one of the Federal Policy Authority functions.

One driver of the Federal BCA design was the need to accommodate hierarchical and mesh PKI implementations that are already common within the Federal Government. Both hierarchical and mesh PKIs are operated by U.S. Federal Government commercial and government partners. The BCA concept enables applications capable of processing mesh PKI certificates to interoperate with any mesh or hierarchical PKI cross-certified with the BCA.

Some commercial clients already include the certificate path development and validation capabilities needed to take advantage of the BCA. Other vendors are now upgrading their PKI client applications with the features necessary to operate with the BCA. Figure 8.1-20 illustrates the planned architecture of the Federal PKI.<sup>5</sup>

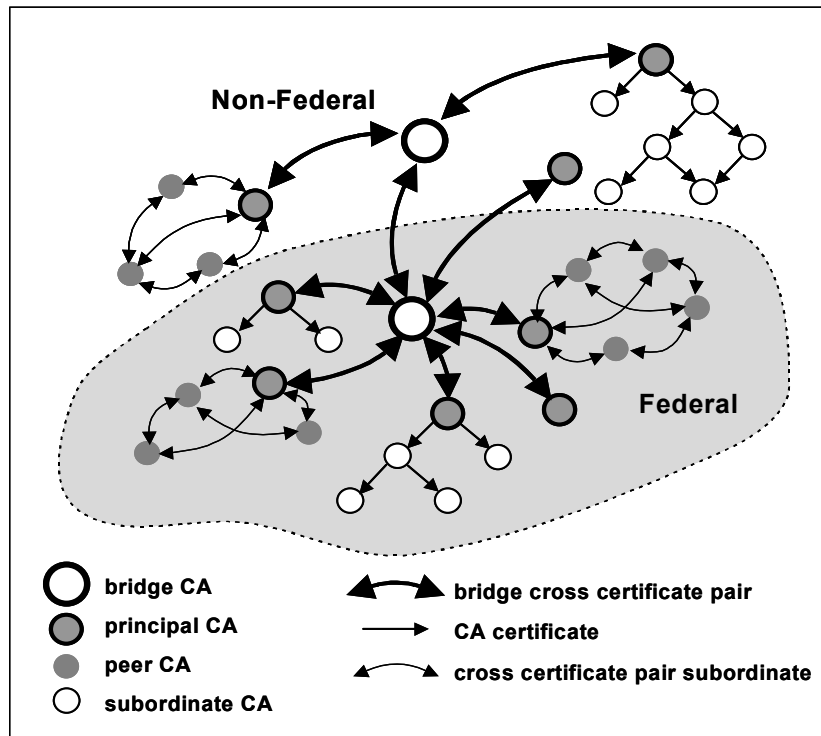

iattf\_8\_1\_20\_0059

Figure 8.1-20. Federal PKI Architecture

<sup>5</sup> Figure 8.1-20 courtesy of the Federal PKI Web page at <http://csrc.nist.gov/pki/twg/welcome.html>.



The BCA will actually consist of a variety of CA products that are mutually cross-certified. This design allows several vendors to operate within the BCA “membrane,” thus allowing for continued BCA operation in the face of a dynamically changing PKI technology and vendor environment.

## 8.1.7.5 Corporate PKI

### 8.1.7.5.1 Introduction

This section describes how the Microsoft Information Technology Group (ITG) built a PKI by deploying a hierarchy of CAs hosted on Microsoft Windows 2000 servers. The name of this project was the Crypto Management Architecture PKI. In this discussion, it will be shortened to CMA PKI.

### 8.1.7.5.2 Requirements

Microsoft is implementing and using many security technologies to protect and maintain the integrity of digital intellectual property. A large number of these security technologies depend on the use of valid X.509 certificates issued by trusted CAs.

The CMA PKI must support the deployment of the technologies listed in Table 8.1-5 to satisfy the corresponding business requirements:

**Table 8.1-5. Business Requirement and Security Technology Comparison**

<b>Business Requirement</b>	<b>Security Technology</b>
Employees in all Microsoft business units need to exchange encrypted and/or digitally signed e-mail with each other, external business partners, and customers over the Internet and other untrusted networks	Secure Multipurpose Internet Mail Extensions (S/MIME)
Secure networking with a common transport/tunnel technology supported by uniform authentication architecture	Internet Protocol Security (IPSec) and Layer 2 Tunneling Protocol (L2TP)
Users must be able to store encrypted data securely, whereas the corporation must be able to recover data should an employee leave or lose his/her encrypting certificate	Encrypting file system (EFS) and EFS recovery policies
Reduce the costs of purchasing certificates from outside sources by providing internally generated certificates for all intranet and most extranet SSL servers.	Secure Sockets Layer (SSL) or Transport Layer Security (TLS)
Strong authentication	Smart cards
Replace the practice of giving various external business partners shared corporate network accounts by trusting certificates from vendors and business partners	Certificates
Nonrepudiation	Digital signatures

Additional requirements are as follows:

- Active Directory integration (e.g., CRLs, certificate enrollment, certificate templates, and CA certificates available via Active Directory).
- Certificates mapped to users and computers in Active Directory.
- Servers and client computers automatically enrolled for certificates (i.e., autoenrollment).
- Interoperability with Exchange Key Manager Server (KMS) and Outlook.
- A healthy foundation for the expansion of Microsoft's corporate PKI to support forthcoming confidentiality, integrity, and authentication features in Microsoft products.

### 8.1.7.5.3 PKI Design

#### The Inherited PKI

At the beginning of the CMA PKI project, Microsoft already had a PKI managed by Legal and Corporate Affairs (LCA) and Product Release Services (PRS). This PKI, which was developed to support various product group and manufacturing efforts, was not used for general corporate functions.

Because Microsoft's root authority (MSROOT) in the inherited PKI is the top of the company's certification hierarchy for digitally signing all of its software products, a compromised MSROOT would have very negative national and global consequences. Therefore, the CAs that make up the inherited PKI are located in a secure vault on the Microsoft campus. The vault cannot be entered by a single individual; rather, it must always be entered by two authorized individuals simultaneously. The vault also has been designed to withstand attacks by cutting torches, explosives, and other brute force tools of nefarious individuals.

#### CMA PKI Topology

The CMA PKI has CAs in a three-level rooted hierarchy:

- **Level 1: Microsoft Corporate Root Authority.** The root CA at the top level of the hierarchy signs its own certificate. ITG makes it available to all entities that may want to establish trust in it.
- **Level 2: Microsoft Intranet CA and Microsoft Extranet CA.** The CAs below the root CA in a three-level hierarchy are referred to as policy CAs or intermediate CAs. These CAs have certificates issued from the root CA and can be online or offline; ITG chose to keep the intermediate CAs offline for security reasons.
- **Level 3: Microsoft Intranet CAs.** The third level in a rooted hierarchy contains the issuing CAs. An issuing CA, as the name implies, issues certificates to end-entities.

## UNCLASSIFIED

Key Management Infrastructure/Public Key Infrastructure  
IATF Release 3.1—September 2002

Issuing CAs are normally online CAs—in other words, they are always connected to the network.

### ***Certification Authority Servers***

To establish the CMA PKI, eight CAs needed to be built. Three of the new CAs are off line and reside in the LCA vault. The other five CAs will be online and service requests 24 hours a day, 7 days a week. These servers will reside in the ITG vault.

### ***Microsoft Corporate Root Authority***

The Microsoft Corporate Root Authority is a Windows 2000 CA. This represents the top of the Corporate PKI and is used only to sign/certify subordinate CAs. This server will be off line, except with generating revocation lists or signing CAs, and will reside in the current LCA vault. This server should be built with the following parameters:

- Windows 2000 Certificate Server (Stand alone Root CA).
- Self-signed CA certificate.
- Hardware-based Crypto Service Provider (CSP).
- 8-year CA lifetime.
- 2,048 CA key length.
- 90-day CRL publishing interval.
- CRL locations: LDAP to Active Directory; HTTP to [crl.microsoft.com](http://crl.microsoft.com).

### ***Microsoft Intranet CA***

The Microsoft Intranet Certification Authority will certify all other CAs used for internal purposes. This server will be off line except with generating revocation lists or signing CAs, and will reside in the current LCA vault in. This server should be built with the following parameters:

- Windows 2000 CA (Stand alone Subordinate CA).
- Install certificate from a PKCS#7 text file from the Microsoft Corporate Root Authority.
- Hardware-based CSP.
- 5-year CA lifetime.
- 2,048 CA key length.
- 90-day CRL publishing interval.
- CRL locations: LDAP to Active Directory; HTTP to [crl.microsoft.com](http://crl.microsoft.com).

### ***Microsoft Intranet Network CA***

The Microsoft Intranet Network Certification Authority will issue end-entity certificates for services that relate to general server, user, or network administration, such as Administrator certificates, EFS recovery certificates, router (IPSec/L2TP) certificates, and smart card enrollment agent certificates. The servers comprising this CA will be continuously on line, will

## UNCLASSIFIED

Key Management Infrastructure/Public Key Infrastructure  
IATF Release 3.1—September 2002

require redundancy, and will reside in the ITG vault. These servers should be built with the following parameters:

- Windows 2000 CA (Enterprise Subordinate CA).
- Install certificate from a PKCS#7 text file from the Microsoft Intranet CA.
- Hardware-based CSP.
- 2-year CA lifetime.
- 2,048 CA key length.
- 24-hour CRL publishing interval.
- CRL locations: LDAP to Active Directory; HTTP to itgweb.corp.microsoft.com.

### ***Microsoft Intranet FTE User CA***

The Microsoft Intranet User Certification Authority will issue end-entity certificates to full-time employees (FTE) users on the corporate network for general client authentication, EFS, and smart card logon. The servers comprising this CA will be continuously on line, require redundancy, and reside in the ITG vault. These servers should be built with the following parameters:

- Windows 2000 CA (Enterprise Subordinate CA).
- Install certificate from a PKCS#7 text file from the Microsoft Intranet CA.
- Hardware-based CSP.
- 2-year CA lifetime.
- 2,048 CA key length.
- 24-hour CRL publishing interval.
- CRL locations: LDAP to Active Directory; HTTP to itgweb.corp.microsoft.com.

### ***Microsoft Intranet Non-FTE User CA***

The Microsoft Intranet User Certification Authority will issue end-entity certificates to non-FTE users on the corporate network for general client authentication, EFS, and smart card logon. The servers comprising this CA will be continuously on-line, require redundancy, and reside in the ITG vault. These servers should be built with the following parameters:

- Windows 2000 CA (Enterprise Subordinate CA).
- Install certificate from a PKCS#7 text file from the Microsoft Intranet CA.
- Hardware-based CSP.
- 2-year CA lifetime.
- 2,048 CA key length.
- 24-hour CRL publishing interval.
- CRL locations: LDAP to Active Directory; HTTP to itgweb.corp.microsoft.com.

## UNCLASSIFIED

Key Management Infrastructure/Public Key Infrastructure  
IATF Release 3.1—September 2002

### ***Microsoft Extranet CA***

The Microsoft Extranet Certification Authority will certify all other CAs used for external purposes. This server will be off line except with generating CRLs or signing CAs and will reside in the current LCA vault. This server should be built with the following parameters:

- Windows 2000 CA (Stand alone Subordinate CA).
- Install certificate from a PKCS#7 text file from the Microsoft Corporate Root Authority.
- Hardware-based CSP.
- 5-year CA lifetime.
- 2,048 CA key length.
- 90-day CRL publishing interval.
- CRL locations: LDAP to Active Directory; HTTP to [crl.microsoft.com](http://crl.microsoft.com).

### ***Microsoft Personnel E-Mail CA***

The Microsoft Personnel E-Mail Certification Authority will issue end-entity certificates used for digitally signing and encrypting email (S/MIME). The server hosting this CA will be continuously on line, require redundancy, and reside in the ITG vault. These servers should be built with the following parameters:

- Windows 2000 CA (Enterprise Subordinate CA).
- Install certificate from a PKCS#7 text file from the Microsoft Extranet CA.
- Hardware-based CSP.
- 2-year CA lifetime.
- 2,048 CA key length.
- 24-hour CRL publishing interval.
- CRL locations: LDAP to Active Directory; HTTP to [crl.microsoft.com](http://crl.microsoft.com).

## **8.1.7.6 Other Implementations**

### **Kerberos Solution**

Kerberos provides another approach for IA and network security. [7] Kerberos is a network authentication protocol designed to provide strong authentication for client/server applications by using secret-key cryptography. A free implementation of this protocol is available from the Massachusetts Institute of Technology (MIT). Kerberos also is available in many commercial products.

The Internet is an insecure place. Many of the protocols used in the Internet do not provide any security. Tools to “sniff” passwords off the network are in common use by systems crackers. Thus, applications sending an unencrypted password over the network are extremely vulnerable. Worse yet, other client/server applications rely on the client program to be “honest” about the identity of its users. Other applications rely on the client to restrict its own activities with no additional enforcement by the server.

Some sites attempt to use firewalls to solve their network security problems. Unfortunately, firewalls assume incorrectly that the hackers are on the outside. Insiders carry out most of the really damaging incidents of computer crime. Firewalls also have a significant disadvantage in that they restrict how users can use the Internet. Firewalls are simply a less extreme example of the dictum that there is nothing more secure than a computer that is not connected to the network—and powered off! In many places, these restrictions are simply unrealistic and unacceptable.

Kerberos was created at MIT as a solution to these network security problems. The Kerberos protocol uses strong cryptography so that a client can prove its identity to a server (and vice versa) across an insecure network connection. After a client and server have used Kerberos to prove their identities, they can also encrypt all of their communications to assure privacy and data integrity as they conduct their business.

Kerberos is freely available from MIT, under a copyright permission notice very similar to the one used for the Berkeley Software Distribution (BSD) operating system and X11 Windowing system. MIT provides Kerberos in source form, so that anyone who wishes to use it may look over the code to assure themselves that the code is trustworthy. In addition, for those who prefer to rely on a professional supported product, Kerberos is available as a product from many different vendors.

In summary, Kerberos is another approach to network security problems. It provides the tools of authentication and strong cryptography over the network to help secure your information systems across the entire enterprise.

## References About Kerberos

- More information about Kerberos can be found on the Internet at <http://www.isi.edu/gost/info/kerberos>
- An excellent introductory article can be found at <http://www.isi.edu/gost/publications/kerberos-neuman-tso.html>

### 8.1.7.7 Additional References—Supporting Documentation on the Target KMI

As discussed in the roadmap, the Target KMI will be realized in an evolutionary manner through a series of CIs. The definition of the Target KMI provides a perspective for each CI to ensure that the goals established for it will be achieved. Specifically, the Target identifies the physical nodes, allocates the functionality within each node, and specifies the physical interface standards for KMI external and internal boundaries. The KMI program has an ongoing systems engineering activity to define and plan the Target KMI definition. In January 2000, the KMI Program published a series of documents that describes the Target KMI definition that resulted from those activities. These documents include the following:

## UNCLASSIFIED

Key Management Infrastructure/Public Key Infrastructure  
IATF Release 3.1—September 2002

- KMI 2010, Overview and Summary Information.
- KMI 2001, Mission Needs Statement (MNS).
- KMI 2002, KMI Operational Requirements Document (ORD).
- KMI 2000, Functional Requirements Document.
- KMI 2022, Standards and Technology Assessment.
- KMI 2020, System Interface Description.
- KMI 2003, KMI Security Policy and Requirements.
- KMI 2004, KMI Threat Assessment Report.
- KMI 2005, KMI System Security Architecture.
- KMI 2006, KMI Security Risk Analysis/Assessment.
- KMI 2012, Operational View (CONOPS).
- KMI 2011, Program Glossary.
- KMI 2021, Use Case Package (Five Volume Document).
- KMI 8000, Target Architecture Validation Report.

### 8.1.8 Future Trends of Public Key Infrastructure

PKI is one of the most promising technologies on the horizon today to provide strong authentication, data integrity, confidentiality, and nonrepudiation services to a wide user base. The evolution of PKI has been dynamic, and this trend will assuredly continue into the future. Although PKI products have been on the market for years, the technology still lacks maturity. Much work remains to be done by product vendors and implementers. In addition, the public awareness of the benefits of PKI needs to be heightened before PKI will become the “silver bullet” it is intended to be.

One ongoing problem with PKI is incompatibility among vendor solutions. PKI standards need to continue to be developed and proven. Although several major PKI vendors are in the marketplace, many of the current products do not work with those from another vendor. However, many vendors use the specifications provided by the RSA Security Company, which have become in some cases, de facto standards.

There has been a growing trend toward standardization for certificates and cryptographic token storage formats. Through technical exchange meetings with vendors and standards groups, such as the ETF and ITU, it is likely that officially recognized standards will eventually be approved. These standards are vital for PKI to meet the demands for IA. PKI vendors have recognized this, and competing companies have shown increasing willingness to work together to produce common standards.

As better standards emerge, PKI products will improve. For example, the RSA PKCS #12 certificate container format allows private keys and certificates to be stored in a file on a disk. Access to this information can be protected by a password. Because the user chooses the password, a bad password choice can impair the security of the stored certificate. Despite its disadvantages, the PKCS #12 format is the most widely used format and, at present, there is no

widely available alternative that is suitable for replacing PKCS #12. An improved method is needed, but a new method needs to be accepted by the entire industry to become successful.

Vendors that produce interoperable products allow enterprises to purchase PKI equipment with less fear that the purchased product will become obsolete or will no longer be supported. Instead, it is known that the product will operate with others, even if the products are produced by a competitor. When the time comes to upgrade, upgrades are less painful if mature standards are in place. The upgrade can be phased in over time, and there should be a richer set of upgrade features from which to choose. A wide variety of unrelated applications could benefit from a common security solution. A common system reduces the long-term costs associated with maintaining a separate security infrastructure for each application. PKI could provide this solution, and interoperability among a common PKI is important.

Over time, the underlying cryptography of PKI will need to change continuously. It is obvious that new computers are constantly becoming faster. Faster computers will benefit the “brute force” method of cracking encrypted information. As such, the encryption technology must improve to stay ahead. As consumer computers are able to process data to crack the current encryption scheme in a reasonable period of time, data protected by cryptographic techniques becomes more endangered. Even without advances in computer speed, advances in other areas, such as distributed computing, will make encryption upgrades a requirement. A PKI integrator should not assume that a major investment in PKI would be a one-time expense.

### **8.1.8.1 Smart Cards**

One of the promising new PKI implementations will be smart cards, which will provide vast new advantages for PKI. Private keys will be stored in a microchip on the card rather than on a computer disk. The smart card contains not only data, but also a microprocessor to manipulate and protect the stored data. The smart card can control access to private key on the card, and prevent unauthorized manipulation of the data.

Once the private key has been generated by a smart card, the onboard crypto-processor contains the private key. This processor prevents outside access to the private key. Smart cards also offer an alternative to the limitations of the RSA PKCS #12 certificate container by providing additional security to the private key.

Smart cards will provide mobility to PKI users. A single card could be used for physical access to a building, to log in to a computer, and to securely transmit information.

There are some disadvantages to smart cards. An obvious disadvantage is that they might easily become lost or stolen. Although a stolen smart card should not reveal any information to its finder, its legitimate owner might not have a means to access his computer system or might gain access to a building. Another disadvantage of smart cards is that it may be desirable to operate several computer systems, each of which employ a smart card. If a user has only one smart card or does not have enough to use simultaneously, the smart cards will not be useful.



## 8.1.8.2 Biometrics

Biometric devices represent another emerging technology. These devices use physical features or behavior characteristics of human beings to identify a person. Biometric devices will measure unique qualities, such as a person's retina or fingerprint. Upon login, the devices measure the appropriate qualities of the user and then compare those qualities with known qualities, which are stored digitally.

The technology is advancing rapidly. When combined with PKI and smart cards, biometrics offer additional advantages. PKI alone cannot guarantee the identity of a person. The person using the PKI usually enters a password or PIN to access the private key and to identify himself or herself to the PKI. If this password is compromised, the PKI is compromised. Instead of using a password, a user could use a biometric device to authenticate himself or herself to a PKI system via a biometric device. The biometric device provides additional assurance that the person is actually who he or she claims to be. The addition of biometrics is a solution when assurance of authentication to the PKI is essential.

At present, well-chosen and protected passwords can provide a higher level of assurance than biometric devices because of their lower probability of being guessed versus the higher probability of a biometric device mistakenly identifying a person. As biometric devices improve, their accuracy is likely to improve significantly. Biometric devices offer increased value by taking some risks out of user passwords. Examples of password risk include users choosing simple, easily guessed passwords, or users writing passwords on a piece of paper that is not properly secured.

Biometrics is expected to grow significantly in the security field within the next 10 years. Although prices are still relatively high, biometric devices will come down in time. Several companies are already marketing biometric devices to the public. The combination of biometrics with PKI provides synergy between these two technologies. Biometrics provides a more secure login than a simple password access to one's private key, and PKI allows biometric devices to be used across a wide system infrastructure. Disadvantages to biometrics include not only the users' resistance to the biometrics requirement that their personal qualities (e.g., retina image) be examined or stored, but also the relatively high cost of the biometric devices.

## 8.1.8.3 Certificate Revocation

A certificate revocation scheme needs to be in place to prevent a user's certificates from being valid when a PKI user has his or her access to the PKI removed. For example, an employee who leaves a position or is transferred to another position will likely need to have access removed. Because this user's public key may still exist in the local directories of other users' computers, a method needs to be in place to prevent the certificate from being used. Two leading methods are being investigated to accomplish this effort: CRLs and the OCSP.

CRLs are a comprehensive record of all certificates that have been issued previously but are no longer valid. The CA publishes, and is responsible for, the CRL. The CRL includes the serial

numbers of all certificates that have been revoked. This scheme requires a client wishing to check a certificate against a CRL to download the entire CRL. The CRL would then be searched to discover if any listed certificates match the certificate that the client is checking. An expiration date is included in the CRL, at which time the CRL must no longer be relied on for validation.

The OCSP is another method to ensure the currency of a certificate. A work in progress by the IETF, it employs a client/server approach. A client wishing to validate a certificate sends a request to a server. The request includes a list of certificates or serial numbers that the client wishes to check. The server sends back a reply, which is signed by a CA to ensure the validity of the reply. The reply has several possible responses: Not Revoked, Revoked, On Hold, or Expired.

At present, there is no clear consensus on which method will prevail. Certificate revocation schemes will be a major task of future PKI development.

### **8.1.8.4 Certificate Recovery**

A key recovery system might be employed on some PKIs. The recovery system allows access to the private key through an alternate means. For example, this is useful if the user forgets a password, or management must know the contents of a user's encrypted message. Key recovery systems may be appropriate for encryption keys, but are not recommended for identity keys.

Identity keys are used only for identity purposes. For example, when a user wishes to add nonrepudiation benefits to an e-mail message, the user can sign the e-mail with a private identity key. An encryption key is used to provide confidentiality services. If the user wishes to send a confidential e-mail message, the public encryption key of the addressee would be used. The private key of the addressee is required to view the message contents.

A key recovery system will allow the encrypted data to be made available to the trustees of the key recovery system. Because an identity key is only used to provide identity services, there is no legitimate reason to recover the key. If the password to the identity key is lost, the key can be revoked and a new key issued. A PKI policy can help prevent the misuse of identity keys to falsely impersonate a user by not permitting identity keys to be escrowed in a key recovery system.

Key recovery systems have serious security ramifications. Introducing a key recovery system into a PKI introduces a weak link in the security chain. Although key recovery systems can be a method to help guard against dishonest users, there is no guarantee that a person entrusted with the key recovery system will not be dishonest as well. A security breach in this system could remove virtually all of the security advantages of PKI. In the future, biometric devices might help prevent the lost password problem. If key recovery systems are still desired for other reasons, they should be employed with great care.

## 8.1.8.5 KMI

The KMI is a common structure to administer keying material within DoD. The KMI will eventually administer all keying material throughout DoD. This material includes legacy symmetric key products and public (asymmetrical) key products. As KMI becomes a common administration tool for all DoD keys, it will be used for key registration, key generation, secure key archiving, and key distribution. Additional systems are being examined to study the feasibility of integrated into the KMI.

The KMI architecture will likely consist of several nodes. A CSN will provide data storage, a root certificate authority, archive audit records, and IDSs. A PSN will provide key generation services and certificate generation at the CA level. A PRSN will provide key registration, tracking, directory services, key recovery services, and privilege assignment. The clients node will distribute keys and provide an interface for customer services.

The CSN is envisioned to have KMI databases and library services. It would provide support to supervise the KMI system and could operate at the Secret level. The PSN will likely be designed with a modular construction. The key generation and management functions can be added or deleted as they are needed. The PSN would support new services as they become available. The PRSN would be deployed on the DoD networks (e.g. NIPRNet, SIPRNet) and would be intended for deployment regionally. The PRSN, which would operate at the network's classification level, would provide support for key recovery services within the KMI.

The KMI will likely need to be accredited to operate at system high. Various nodes will operate at, for example, Top Secret-high and Secret-high, as needed. Provisions will be need to in place to isolate nodes with dissimilar classifications and to prevent data cascading to a lower classification. In the future, it is possible that the DoD KMI will interface with other KMIs within the United States and with its allies. Policies will need to be changed to allow crypto data transmission over protected LANs such as SIPRNet.

A KMI and a PKI are closely related technologies, that are designed to work together. The KMI will provide support for the keys that the PKI must use. The PKI program benefits by making use of an existing key infrastructure, while providing new capabilities. According to the NSA KMI Standards and Technology Survey, key management will be accomplished in a similar method to that developed for multicast groups. Policies are constructed for numerous groups. Group keys are created by a group controller, which then distributes them. The Group Secure Association Key Management Protocol (GSAKMP) is then used to distribute the groups' policies and provide for future rekeying of each group when needed.

The KMI is a work in progress. The plans for the system will likely change as it is designed and built. At present, it is uncertain how the KMI will be modified or what additional users it will eventually serve.

### **8.1.8.6 Risks Associated with this Analysis**

This analysis of what PKI will be like in the future consists of predictions based on current trends today. The PKI momentum has been building for several years and is likely to continue. However, PKI has shown fairly slow growth so far. The growth is not widespread at present outside a few select industries. As standards and new technologies mature, PKI will likely become much more important.

There are several risks in predicting the future trends of PKI. Usability will be an extremely important factor in the PKI maturation. Although important advances in this area have been made, more will need to occur in the future. It is also possible that another technology will emerge that can provide similar benefits and will be more efficient to deploy. At present, the future of asymmetric keys to provide strong authentication, data integrity, confidentiality, and nonrepudiation services appears to be solid. PKI is the technology most likely to benefit from the advantages of asymmetric keys to provide these services.

### **8.1.8.7 Conclusions**

PKI can be expected to grow vigorously in the next 5 to 10 years. As standards are developed and more applications are supplied with PKI built in, the PKI will grow more quickly. It is possible that one or more competing technologies also will arise on the security scene, but such a technology will likely provide similar capabilities that PKI promises. The advantages of PKI will be the flexibility to adapt to new applications and to provide a common security architecture that can be deployed for many applications, involving both computers and other devices.

The future of PKI will depend largely on its usability. Even the best security resources cannot provide security if they are not accepted by end users. PKI offers numerous benefits and is intended to be used for more than one application. For example, an e-mail system may use PKI for confidentiality and nonrepudiation across an enterprise and to operate with external enterprises. A database system might use the same PKI to provide confidentiality and nonrepudiation plus authentication to the database. As more applications use a common PKI, additional economies of scale can be realized. Existing applications will need to be replaced with newer software that is PKI compliant, or PKI enabled. Application integration will likely be one of the most difficult and most expensive phases of adopting a common PKI system.

## UNCLASSIFIED

Key Management Infrastructure/Public Key Infrastructure  
IATF Release 3.1—September 2002

### References

1. International Telecommunication Union (ITU), 1997, Information Technology—Open Systems Interconnection—The Directory: Authentication Framework, ITU-T Recommendation X.509.
2. RSA Laboratories, November 1, 1993, PKCS#10: Certification Request Syntax Standard, Version 1.0.
3. RSA Laboratories, November 1, 1993, PKCS#7: Cryptographic Message Syntax Standard, Version 1.5.
4. Bruce Schneier. Applied Cryptography, pp. 139-152.
5. PKIX –4. Public-Key Infrastructure (X.509) (pkix), August 7, 2000  
<http://www.ietf.org/html.charters/pkix-charter.html>.
6. PKI Profile. NIST PKI Program February 23, 2000, <http://csrc.nist.gov/pki>.
7. Massachusetts Institute of Technology's Kerberos: The Network Authentication Protocol Web Site, June 24, 2000, <http://web.mit.edu/kerberos/www>.

### Additional References

- a. Furlong, Judith, Public Key Infrastructure (PKI) Scenarios Overview, November 20, 1997.
- b. University of Southern California The Kerberos Network Authentication Service  
<http://www.isi.edu/gost/info/kerberos>.
- c. B. Clifford Neuman and Theodore Ts'o. Kerberos: An Authentication Service for Computer Networks USC/ISI Technical Report number ISI/RS-94-399. September 1994,  
<http://www.isi.edu/gost/publications/kerberos-neuman-tso.html>.
- d. The Moron's Guide to Kerberos, Version 1.2.2,  
<http://www.isi.edu/gost/brian/security/kerberos.html>.

## 8.2 Detect and Respond as a Supporting Element

A fundamental tenet of the defense-in-depth strategy embraced by this Information Assurance Technical Framework (IATF) is to prevent cyber attacks from penetrating networks, and to detect and respond effectively to mitigate the effects of attacks that do. An integral aspect of this strategy is a secure infrastructure to support the detection of and reaction to cyber incidents and attacks.

### 8.2.1 What This Focus Area Addresses

Detect and respond capabilities are complex structures that run the gamut of intrusion and attack detection, characterization, and response. The progression of detect and respond technologies is building from audit logs and virus scanners to a more robust capability. While technology continues to evolve, this overall area remains heavily dependent on highly skilled operators and analysts.

#### 8.2.1.1 Scope of This Focus Area

The local environments (within an enclave) are the logical location for network-based and host-based sensors. Sections 6.4, Network Monitoring within Enclave Boundaries and External Connections, 6.5, Network Scanners within Enclave Boundaries, and 7.2, Host-Based Detect and Respond Capabilities within Computing Environment, address specific Framework guidance for these sensors. This section addresses the processes and technologies that are typically required beyond the sensors. This includes discussions of architectural considerations for improving the Detect and Respond posture of an enterprise, evolving paradigms for a Detect and Respond infrastructure, the various processes and functions that are performed within the secure infrastructure, and the technologies that are available to realize these processes and functions. The section concludes with sources for additional information and a list of references used in developing this guidance.

#### 8.2.1.2 Terminology

To set the stage for the discussions in this section of the Framework, there are a number of terms that should first be defined. We recognize that these terms, which are fundamental to the discussions in this section, are also germane to many sections of the Framework. We also appreciate that these terms have varying interpretations within the community, so we include the following definitions to eliminate possible confusion or ambiguity within this section of the Framework.

The first set of terms deals with threats and vulnerabilities. A threat exists when an intruder (also referred to as an adversary or a threat agent) has the means, motivation, and opportunity to

## UNCLASSIFIED

Detect and Respond as a Supporting Element  
IATF Release 3.1—September 2002

exploit an information system and/or its associated networks. A vulnerability is a weakness or hole that can be exploited by an intruder. An attack is a sequence of events an intruder uses to exploit a vulnerability.

An intrusion can be thought of as a break-in attempt or actual break-in to an information system. The intruder's intent may be to misuse the system or data contained within the system, render a system unreliable or unusable, gain access to the data contained on the system, and/or manipulate the data. Once an intrusion has occurred on an information system, the damage can be extensive—sensitive information may be compromised and network systems or network services can be rendered inoperable. These events can result in the loss of a corporation's competitive edge, lost productivity when network services are unavailable, and costly man-hours and dollars to assess the impact of an intrusion and recover any lost data.

Beyond this, there are various levels of an “attack” that are also worth identifying. We look at attacks from a bottom up perspective, since they are detected based on a logical progression from the point of view of sensors (e.g., intrusion detection system or IDS).

- Alarms are the typical output provided by a sensor as an indication that it believes it detected some evidence of the presence of an intruder.
- Events are actual occurrences of some irregularity that caused an alarm. We distinguish alarms from events in that there are often a number of valid network and host operations that may cause an alarm (thus giving rise to false positive indications).
- Interesting Events are based on the recognition that local environments may experience hundreds of thousands of events daily, and there are typically only a small number that have the potential for any real damage. This category represents those that have the potential for serious impact such as may be characterized in a security policy.
- Incidents are interesting events that actually have serious impact on the information systems and networks of a local environment.
- Attacks are concentrated efforts by an adversary or intruder to have a serious impact on an overall enterprise, usually implemented by a series of incidents targeted at multiple local environments.

While all incidents and attacks are important, the Framework guidance focuses on attacks in which the attacker(s) have the will, resources, and persistence to cause grave harm to an enterprise.

### **8.2.2 Enterprise Architecture Considerations**

While planning for a Detect and Respond infrastructure, it is important to recognize that the enterprise networks and systems that it will support must also be structured to provide information to, and take advantage of, the services and information such a secure infrastructure

provides. The remainder of this section provides guidance on configuring an enterprise to improve its Detect and Respond posture.

## **Incident Reporting**

As highlighted in Sections 6.4, Network Monitoring within Enclave Boundaries and External Connections, 6.5, Network Scanners within Enclave Boundaries, and 7.2, Host-Based Detect and Respond Capabilities within Computing Environment of the Framework, the local environments have the option of deploying sensors, and possibly analysts, to interpret the results of, and, when appropriate, react to the implications of these outputs. Beyond the local environment, each organization, or perhaps community, has to determine what information should be reported, in what format, under what situations, and to whom. The Department of Defense (DoD) has issued implementation guidance and a joint policy for incident and vulnerability reporting. Other system infrastructures simply allow reporting, and leave it to the local environment to work directly with the next tier to decide when, what, and how to report.

## **Network Partitioning and Redundancy, Backup**

Networks are typically configured to provide the most cost-effective service to its users. Whenever feasible, networks should be partitioned into logical segments, with boundary protection devices between segments. This limits traffic flow and thus potential exposure within segments, provides a degree of isolation if one segment or another is subverted, and facilitates the shutting down or limiting of services within affected segments as a possible response. Offering redundant capabilities within a network creates the potential for response options allowing authorized traffic to be diverted around a segment that has been exploited.

## **Deploy Technical Safeguards and Countermeasures as Response Options**

A fundamental aspect of an effective react capability is to deploy safeguards and countermeasures that can be activated to implement responses. Whether they are making changes to firewall policies, filtering router configurations, deception servers, or others, there are a number of such countermeasures available, as discussed in Section 8.2.5.4, Response Tools.

## **Plan for Contingency Operations**

There is an entire discipline associated with disaster planning (sometimes referred to as planning for contingency operations) that includes the development of anticipatory processes and procedures that can facilitate an effective response. These include creating backups of mission-critical and establishing preplanned courses of action (COA). Recommendations regarding the preparation of COAs include the following:

- Plan to deal with high-probability threats and at least acknowledge the less likely possibilities.



## UNCLASSIFIED

Detect and Respond as a Supporting Element  
IATF Release 3.1—September 2002

- Allocate resources to complete and coordinate the planning; create plans in advance rather than waiting for an event to occur.
- Coordinate and obtain approval/acceptance of plans by upper management, business unit managers, and other decision-makers.
- Take advantage of planning that other, similar organizations may have already prepared.
- After the plans are formulated, exercise the procedures to validate the approach, refine the tactics, and train the participants.

When the program is in place, frequently review, update, and enhance it to keep it current.

### Coordinating Responses

Fundamentally, response itself is an issue for the local environments. However, there are a number of factors with implications beyond the perspective of local sites that need to be considered when formulating and evaluating response options as well as when actually responding to an intrusion or attack. A basic decision is whether to shut down an intruder's access (or an entire site) or to allow an intrusion to continue while evidence is collected that will be needed for subsequent prosecution.

### Considerations for Operations

As with the architectural features identified above, there are also complementary operational practices<sup>1</sup> that are important to the overall defense of an enterprise, and again, are directly relevant to considerations for a detect and respond infrastructure:

- Be prepared for severe denial-of-service attacks (e.g., institute and practice contingency plans for alternate services).
- Inspect for physical penetrations.
- Educate users and staff.
- Institute well-known procedures for problem reporting and handling.
- Institute procedures for reporting suspicious behavior.
- Institute and monitor critical access controls (e.g., restrict changeable passwords, require dial-back modems).
- Minimize use of the Internet for mission or time-critical connectivity.

---

<sup>1</sup> Note that it is imperative to perform quality network management and system security administration to maximize the security of the network configuration and mechanisms and to increase the likelihood of detecting and successfully reacting to attacks.

- Require security-critical transactions (e.g., establishing identity when registering) to be conducted in-person.
- Institute and monitor a strict computer emergency response team alert and bulletin awareness and patch program.
- Establish procedures for recovery from attack.

## **8.2.3 General Considerations for a Detect and Respond Solution**

It appears that there are no generally accepted architectural constructs for a detect and respond infrastructure across various communities. However, there are several fundamental considerations for a detect and respond infrastructure that appear to be consistent across communities. These are highlighted below.

### **8.2.3.1 General Constructs for a Detect and Respond Infrastructure**

In general, many network infrastructures are inherently hierarchical by nature, and this one is no exception. When considering a general construct for a detect and respond infrastructure, a primary consideration is the perspective that the system infrastructure layer will maintain for its support. Figure 8.2-1 identifies typical layers in this hierarchy and the perspectives that each layer could offer. Each layer usually retains responsibility for its own operation, and thus must be capable of making decisions about courses of action for its own operation. However, it is seldom the case that any site can function in a completely autonomous fashion without some oversight, coordination, and direction, so there is a natural hierarchy for the decision making as well.

In general, information about incidents, which is usually sensed at the lowest layer in the hierarchy, is reported to higher layers. Warning and response coordination that is more typically derived from higher layers is disseminated from these higher layers down. Again, these are general statements, and any specific situation has to be tailored to the unique needs of the constituent segments.

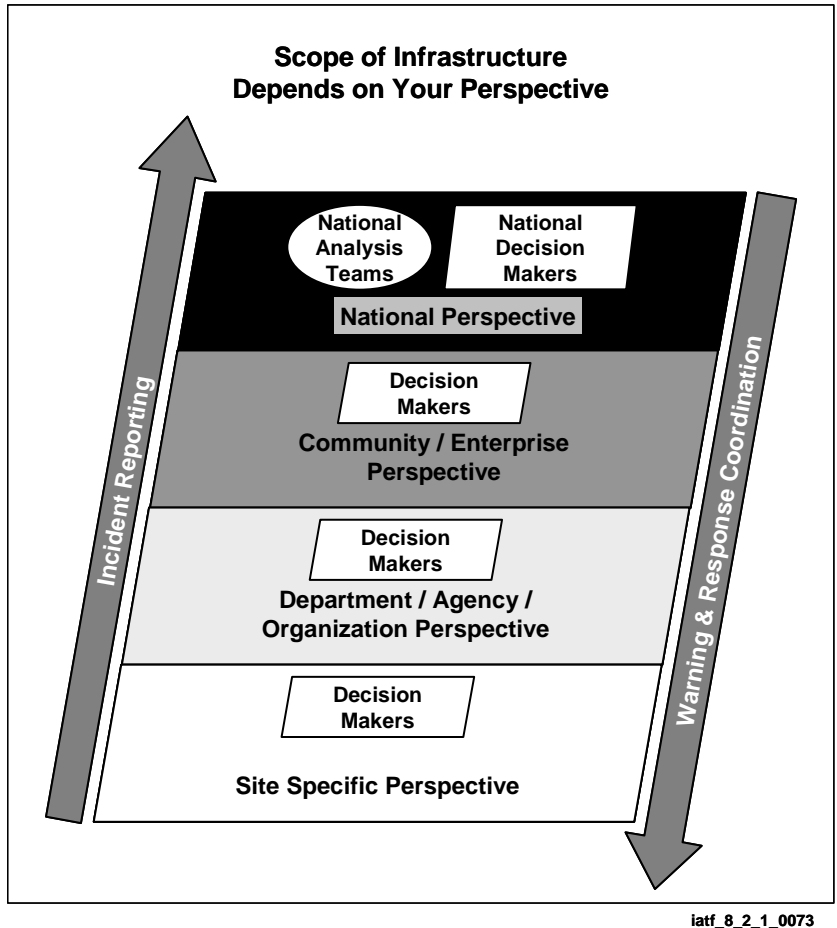
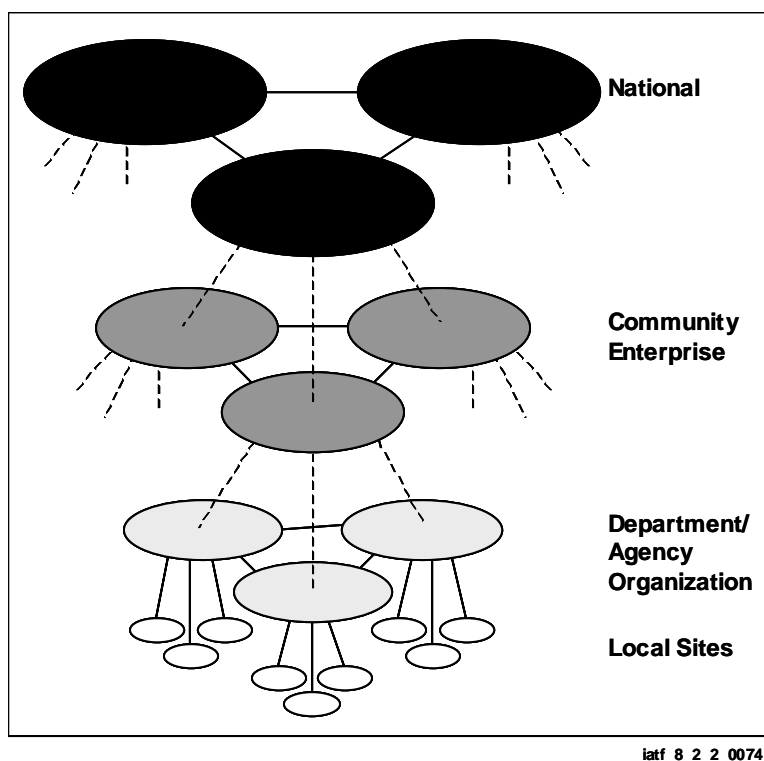

Figure 8.2-1. Perspectives of Layers in a Detect and Respond Infrastructure Hierarchy

### 8.2.3.2 Examples of Existing Detect and Respond Infrastructures

A detect and respond infrastructure of this nature will likely be structured in the manner depicted in Figure 8.2-2. This is consistent with various actual hierarchy structures used today in various communities and enterprises. The specific relationships and responsibilities across the layers differ in actual practice.



**Figure 8.2-2. Basic Hierarchy for Detect and Respond Infrastructure**

For the Department of Defense (DoD), local sites are responsible for deploying network monitors and performing site assessments. Typically each Military Department (MILDEP) has its own Navy Computer Emergency Response Team (NAVCERT) capability or Air Force Information Warfare Center (AFIWC) that is responsible for attack detection and characterization for that MILDEP. At the enterprise level, DoD has established a Joint Task Force for Computer Network Defense (JTF-CND), with a technical analysis capability within the Global Network Operations Security Center (GNOSC) to monitor critical defense networks and coordinate actions across the DoD to restore functionality after an intrusion or attack. The DoD model differs from the others in that reporting and response coordination procedures are mandated.<sup>2</sup>

The civil government agencies have adopted a less formal structure. There is a Federal Computer Emergency Response Team (FEDCERT) that is responsible for coordinating detect and respond activities across the Federal Government, but its use appears to be at the discretion of individual agencies. Selected agencies maintain their own Computer Emergency Response Team (CERT) capabilities (e.g., Department of Energy [DOE] Computer Incident Advisory Capability [CIAC] that is operated at Lawrence Livermore National Laboratories as a central clearinghouse for reporting incidents.) This community also takes some advantage of CERT capabilities from academia (e.g., CERT associated with Carnegie Mellon University actually

<sup>2</sup> The DoD has issued CJCSI 6510.01B, a JCS publication providing implementation guidance and a joint policy for Defensive Information Operations. Within that document, Enclosure D, Appendix G, defines incident and vulnerability reporting procedures, methods, and reporting formats.

funded by DoD). The Federal Intrusion Detection Network (FIDNet), a General Services Administration (GSA) initiative to centralize a federal government-wide capability to analyze local sensor outputs is consistent with this general hierarchy but may be implemented as a managed commercial security service offering available to those agencies that decide to subscribe.

In the private sector, CERTs are available to support those specific organizations that choose to use them, again with reporting and coordination at the discretion of the organization. The Information Sharing and Analysis Center (ISAC), a construct resulting from efforts to implement Presidential Decision Directive 63 (PDD-63), was conceived as a mechanism to structure sector (e.g., banking and finance, telecommunications) coordinators. The intent was to provide a mechanism for enabling appropriate, anonymous, and confidential sharing of information on incidents, threats, vulnerabilities, and solutions associated with each sector's critical system infrastructures and technologies. One ISAC is in place for the banking and finance community. While others have not been put into operation, it is again representative of the use of a hierarchical structure for a detect and respond infrastructure.

At the national level, the National Infrastructure Protection Center (NIPC), established at the Federal Bureau of Investigation (FBI) again in response to PDD-63, is intended to serve as the U.S. Government focal point for threat assessment, warning, investigation, and response to threats or attacks against our nation's critical infrastructures. It is supported by the National Security Incident Response Center (NSIRC) at National Security Agency (NSA) to bring perspectives from the Intelligence Community to perform in-depth analysis (including post-attack investigation) to support activities at the NIPC (and JTF-CND). While these national layers of the infrastructure are called upon at the discretion of other organizations, they maintain a national-level perspective. The NIPC also leads or coordinates activities associated with national security or criminal investigations of cyber crimes.

Although not depicted in Figure 8.2-2, there is some evidence of global infrastructures being established at the international level. One such example is the Forum of Incident Response and Security Teams (FIRST), whose membership includes DoD Service CERTs, academia, and major private corporations from across the globe. Their goals are to foster cooperation among constituents for the protection, detection, and response from computer intrusions. They provide a means for sharing alert and advisory information, and facilitate collaborative planning and sharing of information, tools, and techniques.

## 8.2.4 Detect and Respond Functions

Within the detect and respond infrastructures, a wide range of functions is needed to support operations. In many cases, technology solutions are not available to perform these functions automatically. Analysts, network operators, and system administrators perform many of the functions by applying basic support technologies to ease their tasks. This section provides an overview of the functions that these analysts (with their tools) are attempting to perform. This section begins with an overview of the various phases of operation associated with detect and respond and then highlights specific functions that are representative of each phase. The section

that follows provides a discussion of the underlying technologies that are available to support detect and respond capabilities.

## 8.2.4.1 Phases of Operation

Figure 8.2-3 illustrates the five basic phases of detect and respond. These phases are as follows:

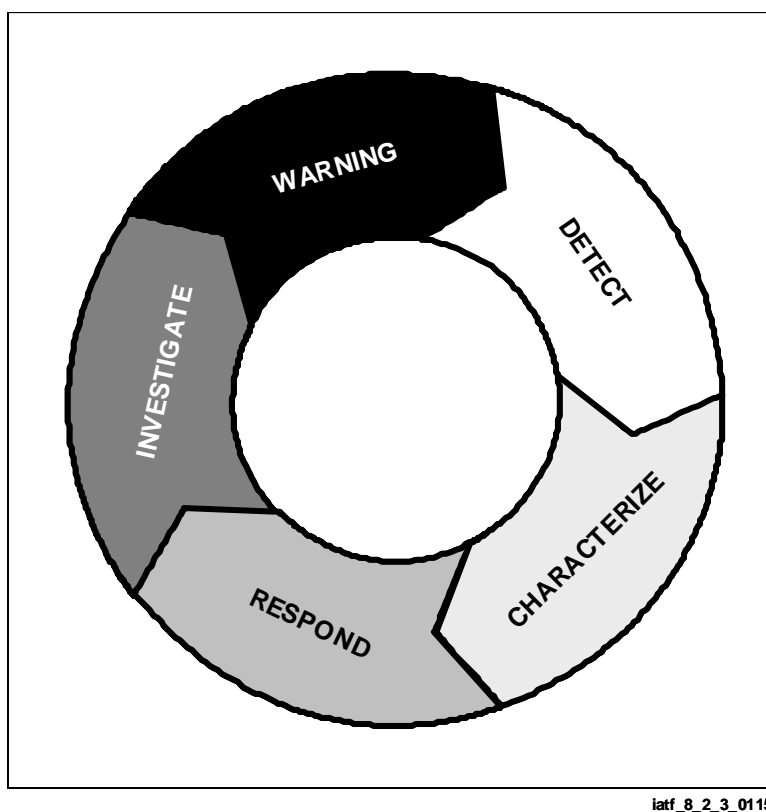

**Figure 8.2-3. Basic View of Detect and Respond Phases**

- **Warning**—Providing advanced notice of a possible impending attack, including a perspective on the attack strategy, scenarios, likely target sites, and timing
- **Detect**—Determining that an attack is occurring or has occurred. This includes the sensing functions discussed in Sections 6.4, Network Monitoring within Enclave Boundaries and External Connections, 6.5, Network Scanners within Enclave Boundaries, and 7.2, Host-Based Detect and Respond Capabilities within Computing Environment, of the Framework, along with broader activities to discern an attack is under way
- **Characterize**—Analyzing the attack in terms of its intent, approach, projections of how it will proceed, likely impacts, and possible identification of the attack source
- **Respond**—Reacting to mitigate the effects of the attack and restore the systems and network

## UNCLASSIFIED

Detect and Respond as a Supporting Element  
IATF Release 3.1—September 2002

- **Investigate**—Analyzing how an attack was accomplished to provide feedback to improve existing protect, detect, and react capabilities to ensure that similar exploitations cannot occur, and when appropriate, to provide evidence when prosecution of attackers is pursued.

From a process standpoint, it is possible to consider detect and respond operations as a series of phases or stages form a life cycle for a particular incident or attack. In this view, it is easy to consider the cycle of phases to begin anew with the occurrence of another attack.

While this perspective is straightforward, it is not really reflective of real-life situations. Although there is sense of “hand-off” from one phase to another, each of the phases is really an ongoing set of processes. For example, warning does not typically stop after an alert is issued.

It continues to search for new indications while detection capabilities focus on those being anticipated. This is typically the same for each phase, as represented in Figure 8.2-4. This sort of twisting view of detect and respond phases may seem whimsical, but is really more indicative of practical operations.

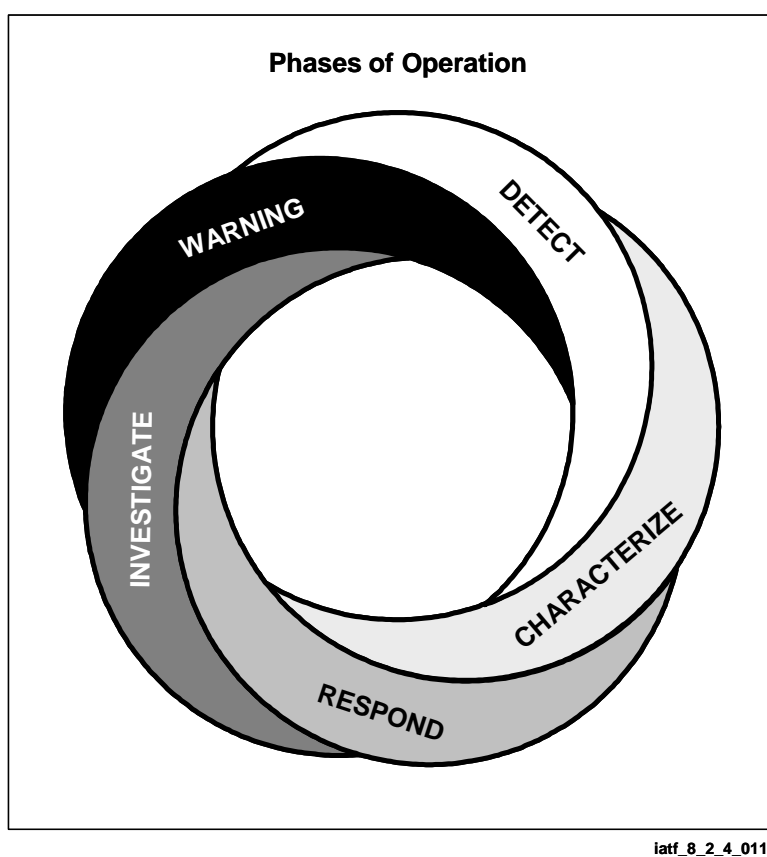

**Figure 8.2-4. Realistic View of Detect and Respond Phases**

There are a number of approaches for realizing these phases within the context of a detect and respond hierarchy. Figure 8.2-5 provides a perspective that can be used when considering allocation of detect and respond functions. While each local site, organization, or enterprise

(community) has the option of allocating detect and respond functions within their hierarchy, it is often the case that warning and attack investigation is provided as a detect and respond infrastructure services because the investigation requires highly skilled analysts and access to broad and diverse sources of information. The other functions tend to follow the perspective on the hierarchy level. Thus, the functions on the left side of Figure 8.2-5 that focus on incidents are typical of those at a local level, or possibly an organizational level. Those on the right side of the diagram that focus on attacks are more indicative of those of a higher level of the system infrastructure (based on the view that attacks are really composed of coordinated incidents across multiple sites).

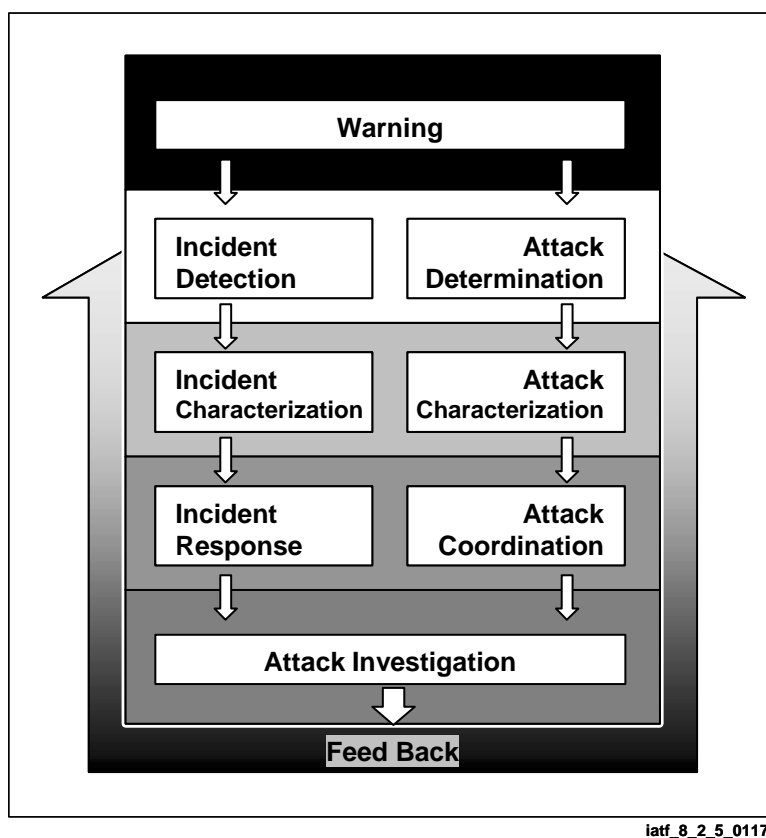

**Figure 8.2-5. Possible Allocations of Detect and Respond Functions**

Another important aspect of these functions is that they are highly dependent on one another. They each rely on, and provide information to others, working toward a common goal of successful detection and response to incidents and attacks. The following section highlights representative processes for each of the eight functions identified in the figure. Again, these are offered not as direction of what functions have to be performed, but to offer a perspective on what detection and response must achieve using the available technologies discussed in subsequent sections.



## 8.2.4.2 Functions to Support Warning

Warning is a proactive capability intended to provide advanced notice (or warning) of possible impending cyber attacks. Figure 8.2-6 offers a perspective on the types of functions that could be implemented to support warning.

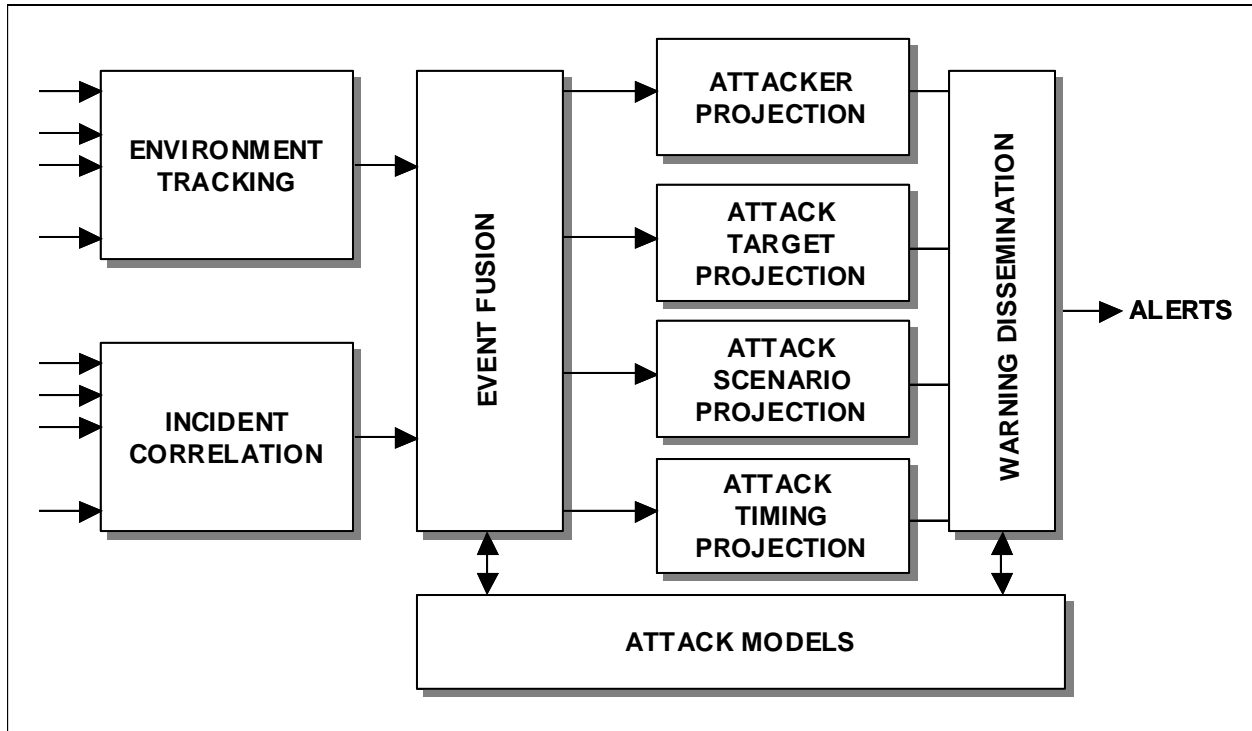

iatf\_8\_2\_6\_0118

**Figure 8.2-6. Functions to Support Warning**

While this is undoubtedly a critical capability for maintaining an effective defensive posture, it is also the least mature. Discussion in the community seems to focus on the identification of precursors to attacks as “observables,” tracking a broad range of social, political, organizational, intelligence, and technical events that can be fused with incident reporting to postulate attacker actions including attack target sites and systems and attack scenarios and timing. Various attack models are used as a foundation for these projections.

### 8.2.4.3 Functions to Support Incident Detection

Detection of incidents (or intrusions) is typical of a local site operation, as discussed in detail in Sections 6.4, Network Monitoring within Enclave Boundaries and External Connections, and 7.2, Host-Based Detect and Respond Capabilities within Computing Environment, of the Framework. In a broad sense, these functions at the local level are performed to determine the security posture and status of a local site (or environment) typically using network-based and host-based sensor technologies, supported by local analysts to identify vulnerabilities, intrusions, and malicious code attacks. Typical functions associated with support to local incident detection are shown in Figure 8.2-7.

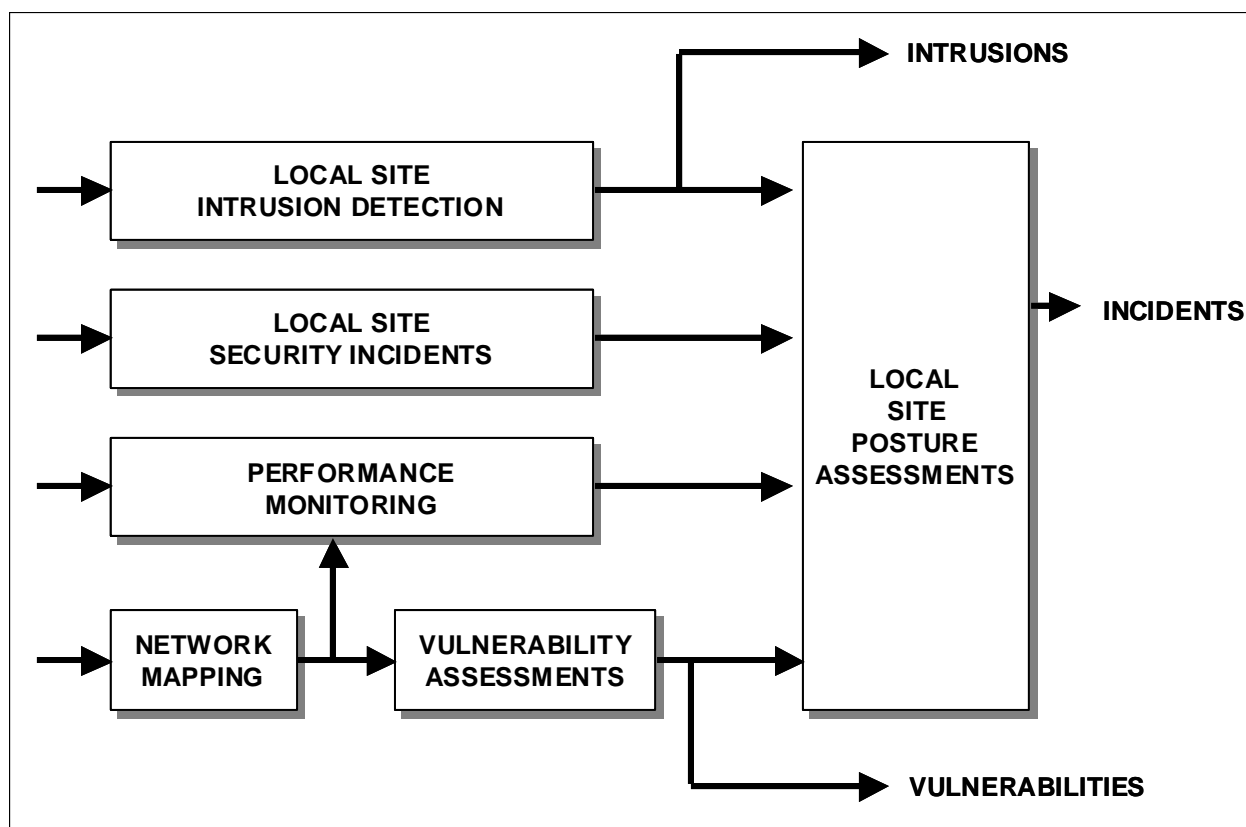

iatf\_8\_2\_7\_0119

**Figure 8.2-7. Functions to Support Local Incident Detection**

To be consistent with other functional structures discussed in this section, we distinguish incident detection from incident characterization, in which operators perform analyses to discriminate between alarms, events, interesting events, and intrusions. As inferred by the diagram, these functions go well beyond intrusion detection to consider security incidents, performance irregularities, and vulnerabilities identified by scanners or penetration (e.g., Red Team) testing.

## 8.2.4.4 Functions to Support Incident Characterization

These functions draw from the results of the incident detection discussed in Section 8.2.4.3, Functions to Support Incident Detection, to interpret the true nature and criticality of each alarm that is created by the local sensors. Typical functions of incident characterization are shown in Figure 8.2-8.

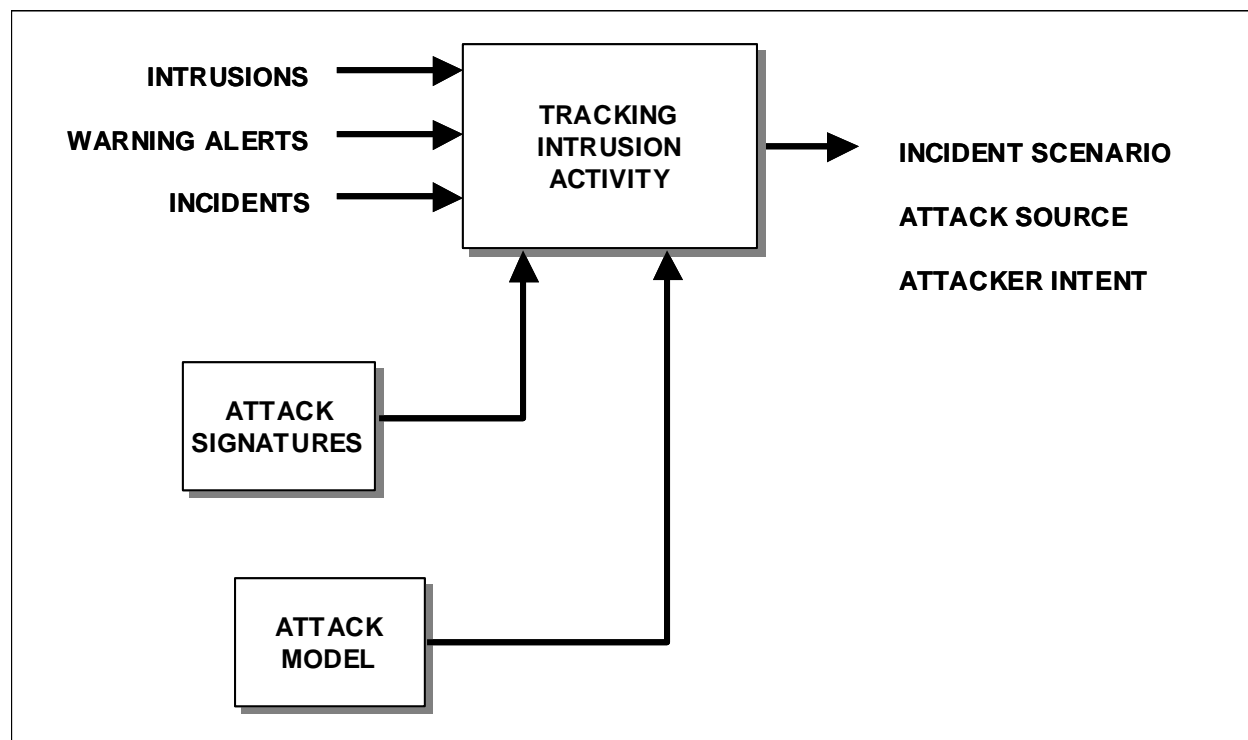

iatf\_8\_2\_8\_0120

**Figure 8.2-8. Functions to Support Incident Characterization**

In addition to the primary inputs from incident detection, warning alerts provide an additional focus on specific attack sources and/or types of attacks. Ideally, the outputs of these functions would provide some sense of an intruder's intent, scenario, and the identification of the source of each incident. Typically, the results of these functions are used as input to the incident response functions, discussed below.

## 8.2.4.5 Functions to Support Incident Response

As discussed earlier, the local environment is ultimately responsible for executing a response to mitigate the effects of the intrusion and to restore the systems and networks. Typical functions of incident response are shown in Figure 8.2-9.

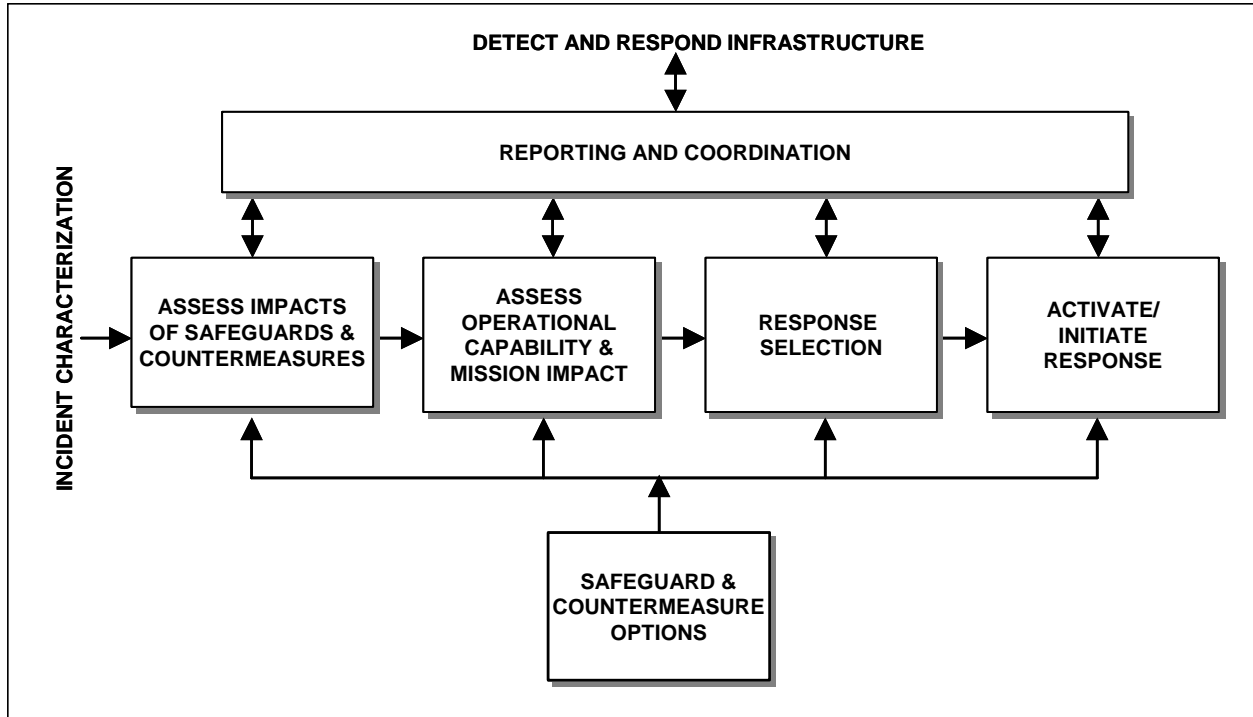

iatf\_8\_2\_9\_0121

**Figure 8.2-9. Functions to Support Incident Response**

These functions draw from a set of preestablished safeguards and countermeasure options. Selection of an appropriate response option would be made based on a number of assessments. These assessments first address the impact (and any anticipated progressions) of the incident on the site's operational capabilities and its ability to perform its missions. The focus is then turned to how the activation of available responses would impact the site's operational capabilities and ability to perform its missions. Coordination with the detect and respond infrastructure (when appropriate) can provide recommendations about the technical impacts that response options may have on incidents associated with ongoing attacks as another factor for consideration in selecting a response. Finally, these functions include the activation of the selected response, intended to contain, assess damage, eradicate, reconstitute, and recover from the effects of the incident (or attack) to the local site capabilities.

## 8.2.4.6 Functions to Support Attack Determination

Building on intrusion and incident reporting from local sites and external events, these functions focus on determining if an attack is under way or has occurred. Typical functions associated with attack determination are shown in Figure 8.2-10.

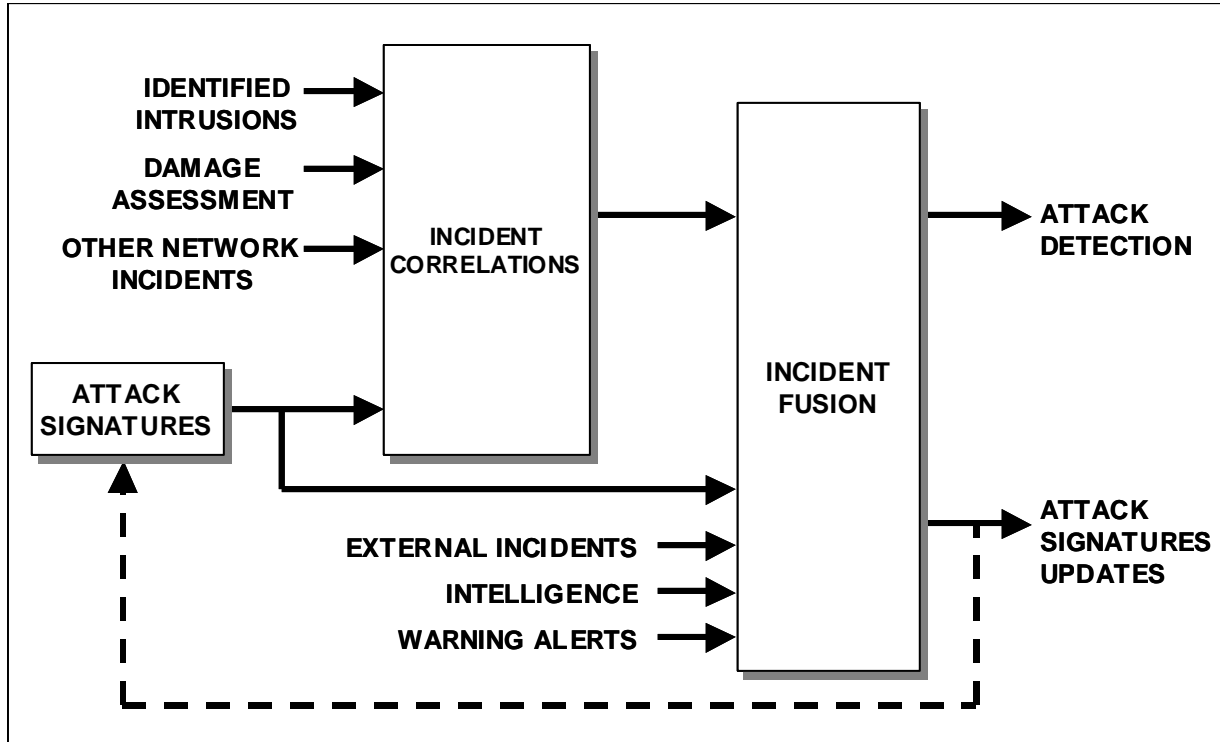

iatf\_8\_2\_10\_0122

**Figure 8.2-10. Functions to Support Attack Determination**

Drawing from the local sensing functions discussed in Sections 6.4, Network Monitoring within Enclave Boundaries and External Connections, 6.5, Network Scanners within Enclave Boundaries, and 7.2, Host-Based Detect and Respond Capabilities within Computing Environment, of the Framework, this activity also includes correlation of incident data from all sites within its constituency and combining that data with warning alerts, all-source intelligence reports, and other external events to discern if an attack is under way.

## 8.2.4.7 Functions to Support Attack Characterization

When the determination has been made that an attack has been detected, this set of functions focuses on analyzing the attack in terms of its intent, approach, projections of how it will proceed, likely impacts, and possible identification of the attack source. Typical functions associated with attack characterization are shown in Figure 8.2-11. The functions can be considered in two categories. The first is fusion of the various sources of information to identify all relevant events and data to be analyzed. The second is a series of specific analysis functions that focus on the various aspects of the characterization.

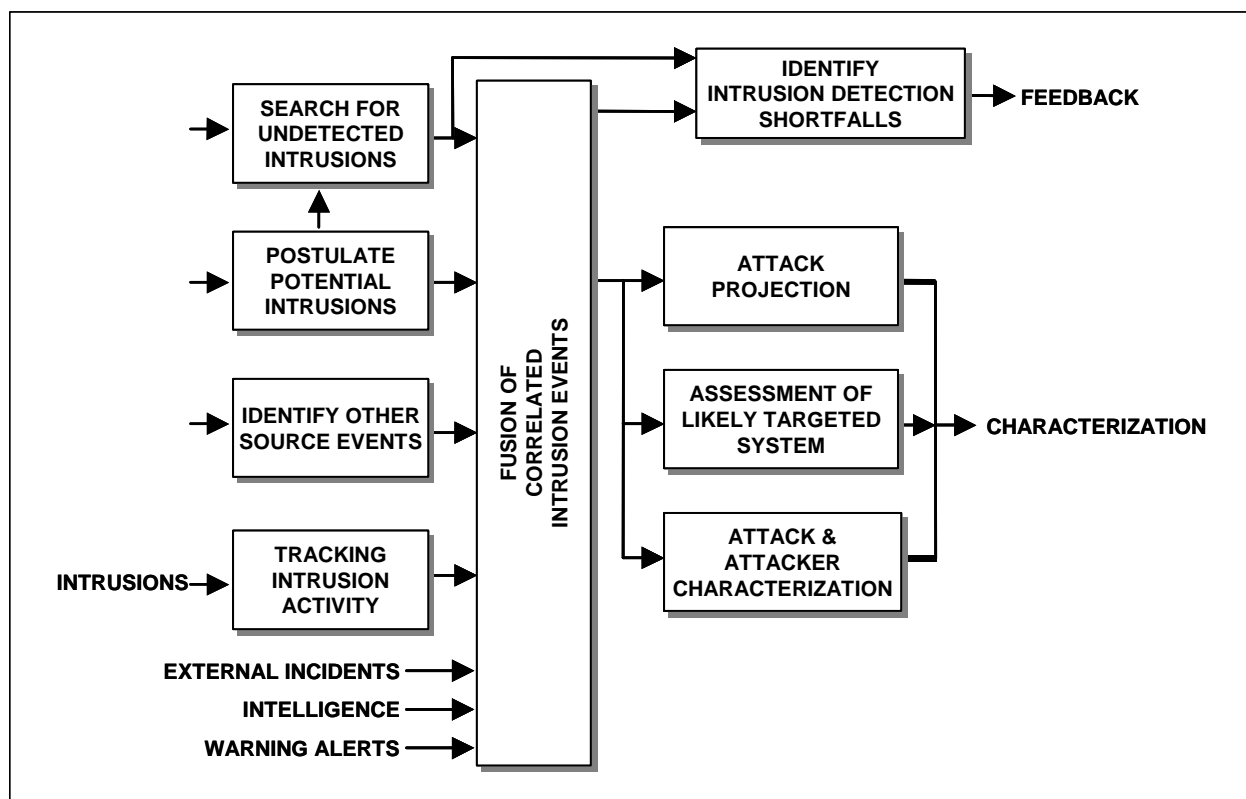

iatf\_8\_2\_11\_0123

**Figure 8.2-11. Functions to Support Attack Characterization**

Resources available to support analysis include warning alerts, all-source intelligence, external incidents, known attack scenarios, and attacker signatures and electronic fingerprints. A side benefit of these analyses is feedback that can be provided to local IDSs to support their tuning, updating their attack scripts, and the like, to improve their detection capabilities as they pertain to the ongoing attack.

## 8.2.4.8 Functions to Support Response Coordination

When an attack has been detected and characterized, the real value the system infrastructure can provide is coordinating an effective response at the local sites that will mitigate the effects of the attack and support the restoration needed to return the systems and networks to normal operation. Typical functions associated with response coordination are shown in Figure 8.2-12. The thrust of these functions is to assess, on a technical (versus operational and mission impact) basis, the effectiveness of available preplanned courses of action, safeguards, and countermeasures against the identified and projected attack scenarios.

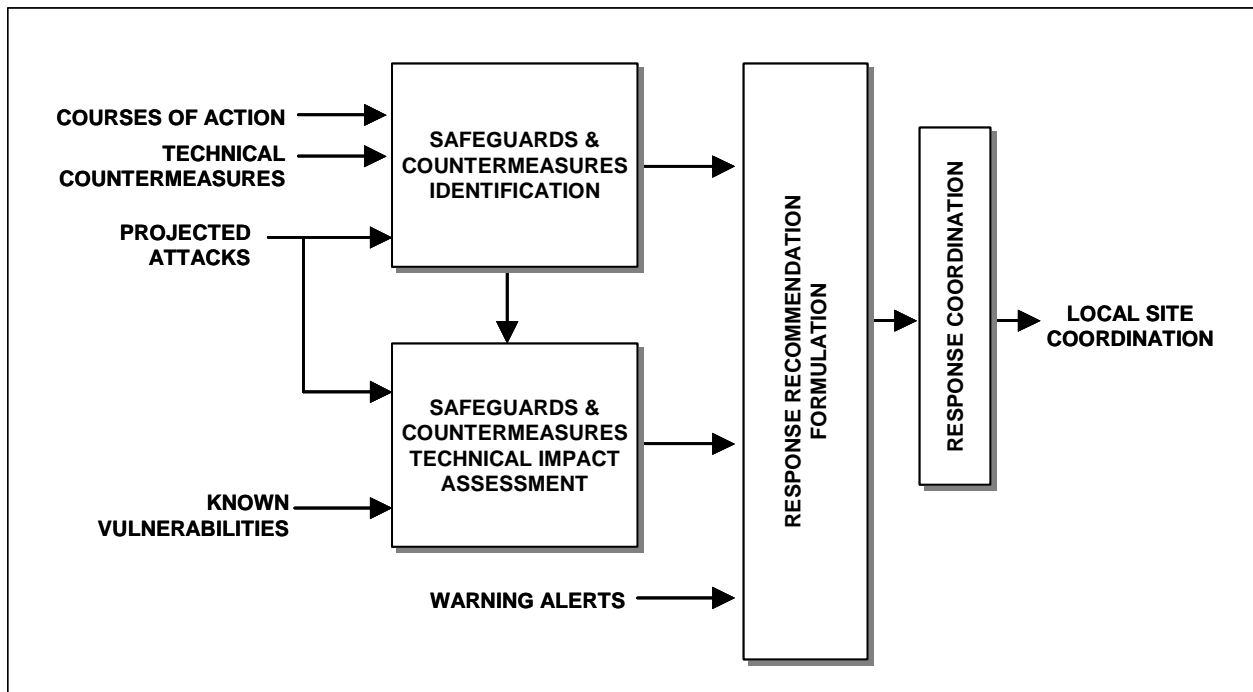

iatf\_8\_2\_12\_0124

**Figure 8.2-12. Functions to Support Response Coordination**

Typically, local organizations and sites are in the best position to assess operational and mission impacts, based on projections of technical impacts to network services and system operations. Recommendations are formulated to assist local sites in the containment, damage assessment, eradication, and restoration to normal operational state. When appropriate, this also includes development or refinement of react mechanisms tailored to unique aspects of the ongoing attack.

## 8.2.4.9 Functions to Support Attack Investigation

This remaining set of functions focuses on analyzing how an attack was accomplished to provide feedback to improve existing (and future) protect, detect, and respond capabilities, ensuring that similar exploitations cannot occur. When appropriate, the investigation also structured to provide evidence of when prosecution of attackers is pursued. Typical functions associated with the attack investigation are shown in Figure 8.2-13. These functions are typically performed after the attack with extended time frames available for in-depth analyses. They can be considered in four basic groups or categories. The first is to establish and maintain a catalog of known vulnerabilities and the effects of known exploitations that provide a foundation for those analyses. These can include determining the effects of known attack sequences and potential modifications to those attack sequences. The second group, which is the primary focus for attack investigation, addresses characterization of the attack and attacker built from any available cyber evidence (e.g., audit logs, Transport Control Protocol [TCP] dumps).

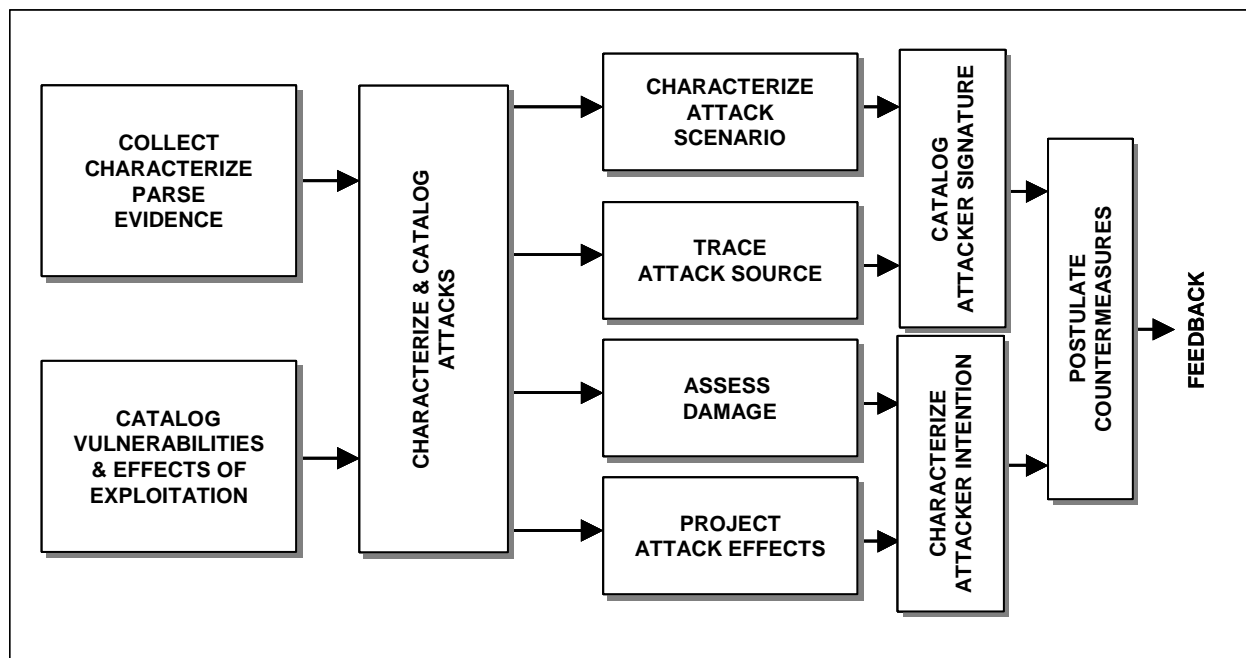

iatf\_8\_2\_13\_0125

Figure 8.2-13. Functions to Support Attack Investigation

When required, this also provides evidence that could be used in subsequent prosecutions of attackers. The third establishes a set of attacker “signatures” (which could be thought of as a fingerprint file) that can be referenced when investigating future attacks. The remaining group focuses on developing and providing feedback for improving countermeasures and safeguards.

## 8.2.5 Relevant Detect and Respond Technologies

Cyber attack detection and response technologies (predominantly focused on intrusions) have emerged within the last several years as a result in large part of situations that stem from the



worldwide interconnectivity created by the Internet. A computer-literate person can gain access into government and commercial internal networks via public routes using software hacking tools that can be easily downloaded from the Internet.

The previous section provided a perspective on the types of functions that are typical for various layers of a detect and respond infrastructure. This section provides guidance on technologies that are available to implement these functions and considerations for their selection and effective use. The section concludes with a reference model that provides an overall context for these technologies in a detect and respond infrastructure setting.

The Defense-in-Depth strategy and the overall Framework reinforce the close relationship of personnel, operations, and technology in realizing an effective information assurance (IA) posture. This cannot be emphasized too strongly across the detect and respond disciplines. When looking at the state of detect and respond technologies, it is clear that there are no “easy answers.” Many of these technologies provide measurement (instrumentation) capabilities that must be interpreted by highly skilled analysts. Other technologies provide tools to support the analysis operations. Even the response technologies require well-trained and highly skilled operators to ensure that the response mitigates, rather than exacerbates, the effects of an incident or attack. Three major issues associated with effective technology deployment are—

- Where in the network they are deployed to ensure they address critical network resources
- How often they are used based on the operational concept of operation and availability of operators and analysts
- What skills the operators and analysts must have to make effective use of the results.

It cannot be over-emphasized that unlike protect technologies, detect and respond technologies do not in themselves offer any real protection. Rather, they enable the processes and functions that can mitigate the effects of an attack and restore the information systems and networks to an operational condition.

### **8.2.5.1 Technology Categories**

Although commercial intrusion detection products have been available for several years, a number of recent and highly publicized hacking cases have created a renewed interest in the broader field of detect and respond technologies. Research by government, industry, and universities is ongoing to determine what constitutes an attack and how to detect and respond to an attack.

Today, most technologies tailored for detect and respond use provide information to an analyst, assist an analysis, or provide a means for responding based on the results of the analysis. Figure 8.2-14 shows the broad range of technologies that are addressed in this section of the Framework.

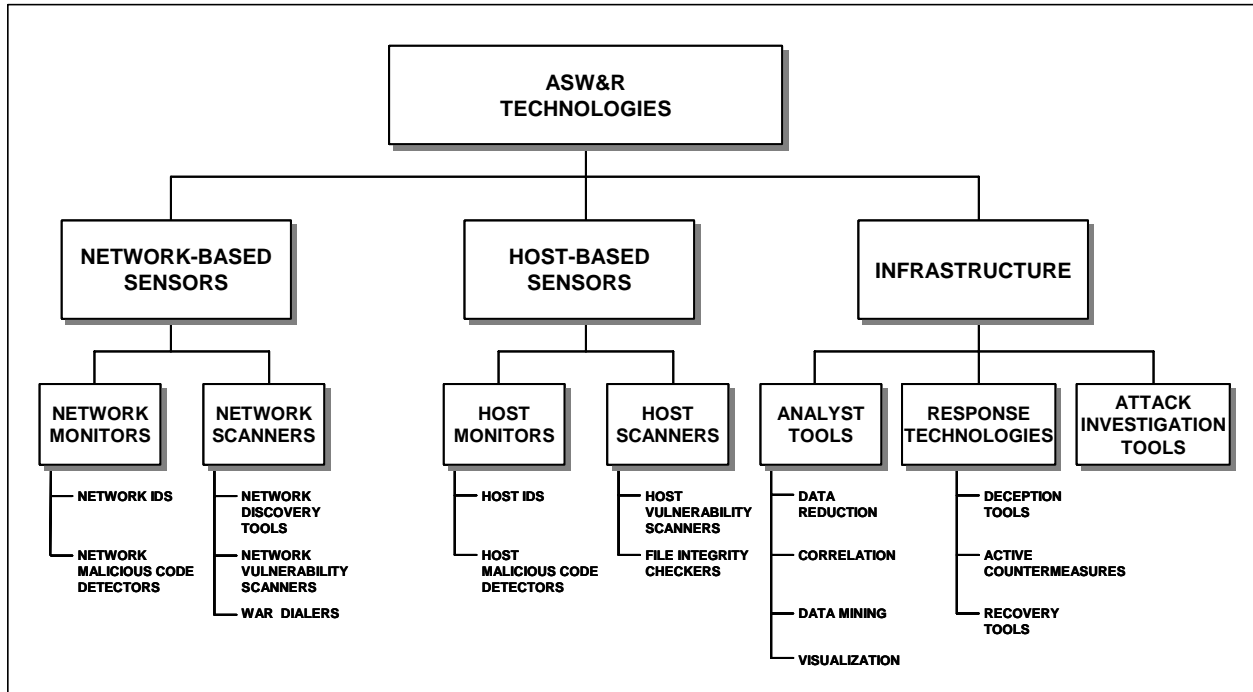

iatf\_8\_2\_14\_0126

Figure 8.2-14. Detect and Respond Technologies

## 8.2.5.2 Monitoring and Scanning Technologies

It should be noted that monitoring and scanning technologies (characterized broadly as sensors) are covered in depth in other sections of the Framework. Specifically Sections 6.4, Network Monitoring within Enclave Boundaries and External Connections, and 6.5, Network Scanners within Enclave Boundaries, address network-based monitoring and scanners, respectively, while Section 7.2, Host-Based Detect and Respond Capabilities within Computing Environment, addresses host-based sensor technologies. This material is synopsized in this section to provide a context for the remaining technologies and to facilitate discussions of when and how to use these technologies in a synergistic fashion. Figure 8.2-15 identifies the general categories of these technologies.

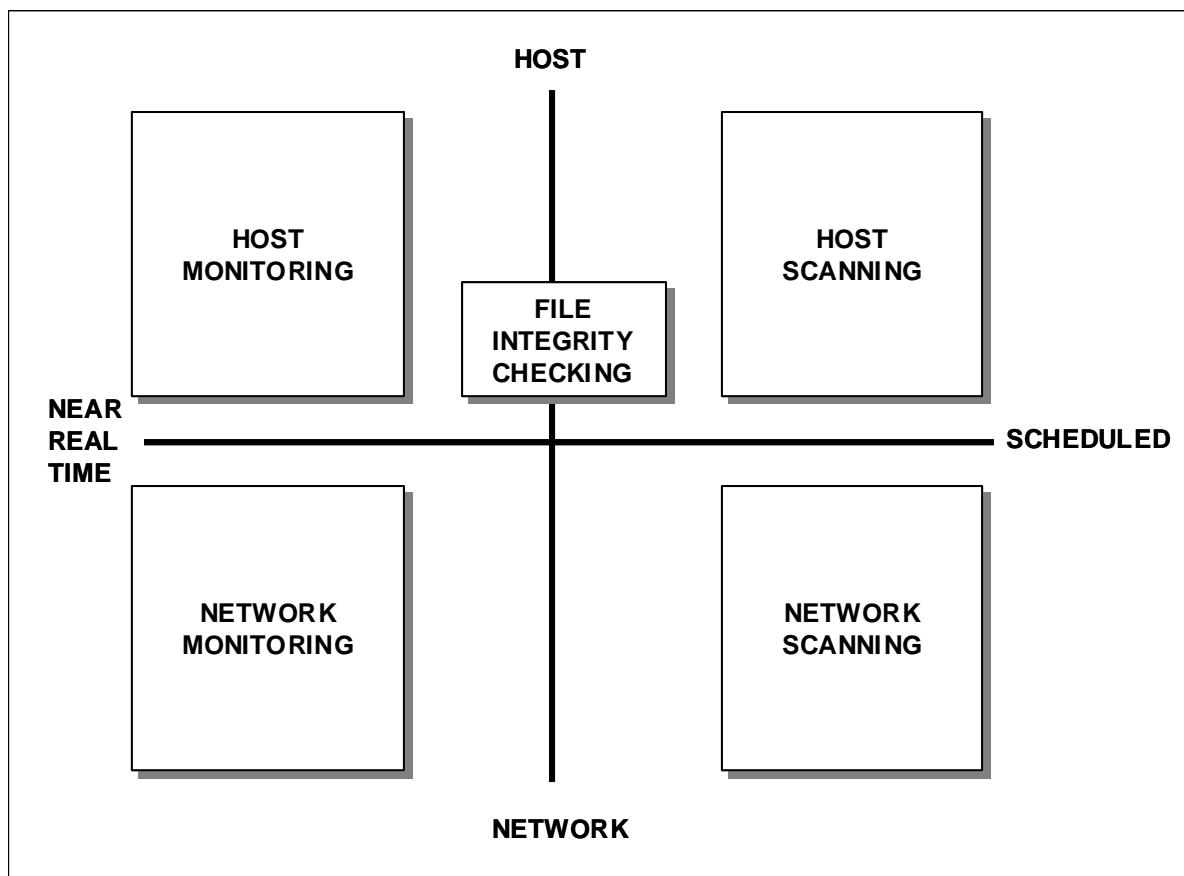

iatf\_8\_2\_15\_0127

Figure 8.2-15. Sensor Technologies Grouping

## Technology Overview

Network and host-based sensors provide alerts and supporting information to network operators and administrators that a vulnerable condition exists or an event has occurred within the enterprise and thus creates an opportunity for them to analyze and evaluate what actually transpired. This allows an appropriate action (as specified by the security policy for the organization) to be initiated. If the attack is detected in real time, it may be possible to mitigate the damage resulting from the attack. If detected after the attack is over, the logging features of the sensors may identify why the attack was successful so that exploitable weaknesses can be fortified.

## Monitors

Network IDSs examine traffic on the wire in real time, examining packets looking for dangerous payloads or signs of abuse (e.g., malformed packets, incorrect source or destination addresses, and particular key words) to spot attacks before they reach their destination and do the damage. When suspicious activity is identified, a network-based IDS is capable of both raising alerts and terminating the offending connection. Some will also integrate with the firewall, automatically

defining new rules to shut out the attacker in the future. As indicated in the earlier sections of the Framework, the high incidents of false positive detection make automated response mechanisms undesirable. Network-based IDSs typically operate on independent computers so there is no impact on the performance of mission systems. They are typically deployed one per network segment, because they are unable to see across switches and routers.

Host intrusion detection provides an agent that resides on each host to be monitored. The agent collects information reflecting the activity that occurs on a particular system. The monitor scans event logs, critical system files, and other auditable resources looking for unauthorized changes or suspicious patterns of activity. When anything out of the ordinary is noticed, alerts or Simple Network Management Protocol (SNMP) traps can be initiated automatically. The agent may also behave in a manner similar to the network-based IDS in that it will examine packets on the wire to compare against a database of known attacks—but in this case, it is restricted solely to packets targeted at the host machine. For this reason, host intrusion detection is ideal in a highly switched environment to protect specific critical servers, or for otherwise heavily loaded networks (where it may be difficult to protect the entire network). Some host-based IDSs also include a “personal firewall” capability to provide additional protection for the host machine. Unlike its network counterpart, host IDSs operate on mission-critical systems, and therefore, their performance impacts mission operations.

Malicious code detectors prevent and/or remove most types of malicious code. The use of malicious code scanning products with current virus definitions is crucial in preventing and detecting attacks by all types of malicious code. Malicious code detectors should be implemented across the enterprise. Defense against malicious code is only as good as its weakest link; if one system can be compromised, the entire enterprise is at risk. Centralized management for the AV capabilities with a common set of policies is strongly recommended.

## **Vulnerability Scanners**

The Framework makes the distinction between scanners and the monitoring devices discussed above. Monitors typically operate in near real time and tend to measure the effectiveness of the network’s protection services in practice since they are subjected to actual exploitation attempts. Scanners, on the other hand, are preventative measures, typically operating periodically (or on demand) to examine systems for vulnerabilities that an adversary could exploit, evaluating effectiveness of the system infrastructure’s protection. Vulnerability scanners sometimes referred to as “risk assessment products” provide a number of known attacks with which network administrators can probe their network resources proactively. Scanners perform rigorous examinations of systems to locate known problems that represent security vulnerabilities.

Host-based scanners use an agent loaded on a system to examine a server or client. This examination can determine the potential system-level vulnerabilities that exist on a particular system based on known vulnerabilities in the operating systems. These technologies typically connect into a management console that can report on the status of all systems with agents across the network.

## UNCLASSIFIED

Detect and Respond as a Supporting Element  
IATF Release 3.1—September 2002

Network-based scanners examine a network and take inventory of all devices and components within the network infrastructure. These components, the network configuration, and the various versions of software controlling the network are examined and compared to a database of known vulnerabilities.

War dialers are a specialized type of network vulnerability scanner technology. Once identified, backdoors can be closed or some type of security plan created to preclude use of that particular point of entry. Along with a strong modem policy describing the need for modem registration and private branch exchange (PBX) controls, war dialer scanning can help an organization defend itself against such dangers. Use of this type of technology can help an enterprise identify vulnerable backdoors (e.g., unsecured modems across an enterprise) before an attack occurs.

File (software) integrity checkers are a specialized type of host scanner technology that verifies the integrity of files, detecting when files have been changed. As with the host vulnerability scanner technologies discussed above, these technologies tend to run off-line, and thus are not a protection mechanism. Typically they operate periodically, based on an event (e.g., file access) or on demand.

### **Considerations for Sensor Deployment and Operation**

Deploying combinations of network and host-based sensors provides the best possible security by monitoring network-based traffic and host-specific exploitations directly on target workstations. This combination provides significant attack protection and facilitates policy enforcement for any size enterprise. Figure 8.2-16 identifies potential locations for their deployment.

When possible, it is recommended that the sensors be linked into the overall system and network management capabilities for an enterprise-wide solution. This eases individual sensor management, facilitates central reporting, and provides a more coherent perspective on the status of the enterprise overall.

Malicious code detectors should be implemented across the enterprise, on every system and network. Most of these technologies provide a means for sending responses or alerts at the server level, and some at the console level. It is always desirable to notify anyone that may have been infected that malicious code has been detected.

If scanners are deployed, it is important to consider what and when scans are performed. Otherwise, it is possible that mission-critical servers become busy responding to simulated attacks during times of peak demand. Assessment frequency is a factor of how often network changes are made as well as the security policy for the enterprise.

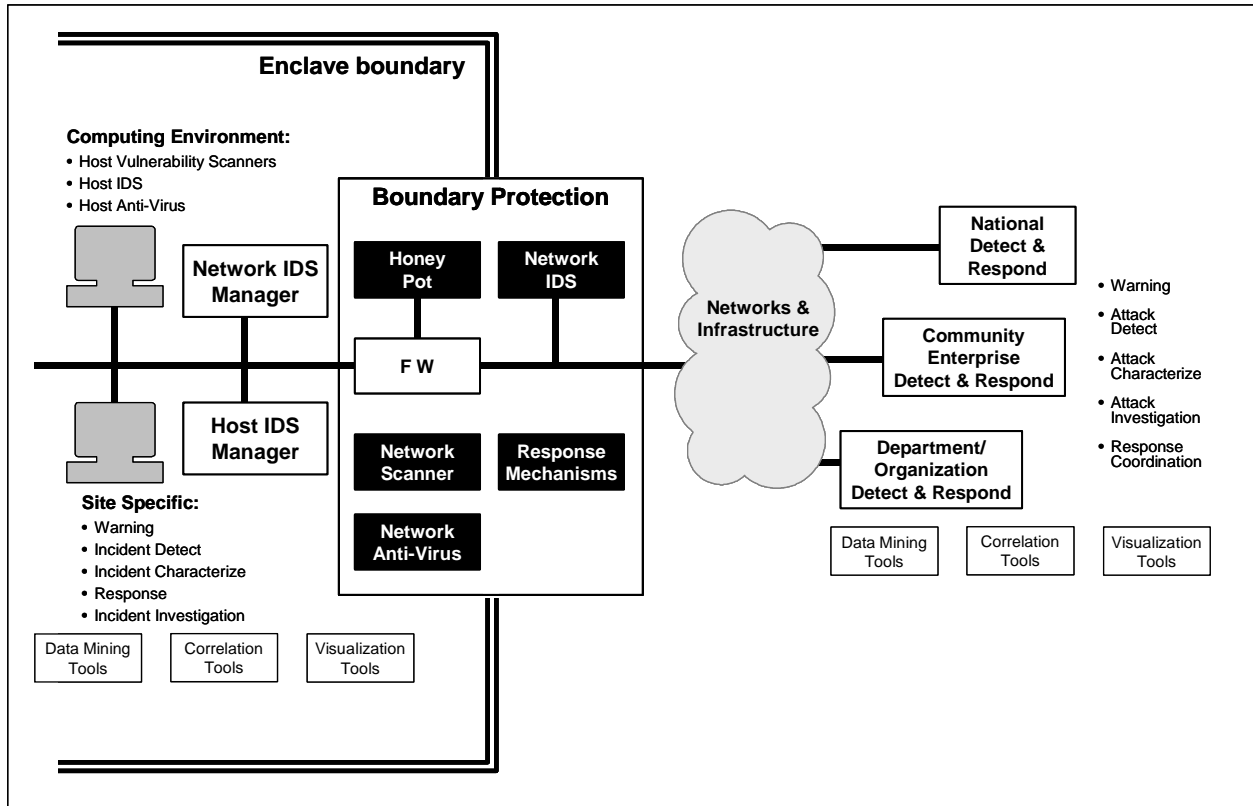

iatf\_8\_2\_16\_0128

Figure 8.2-16. Possible Sensor Deployment Locations

The most important aspect to consider for integrity checker operation is deployment timing. To be their most effective, integrity checkers should be initialized on systems before they are placed into production and made generally accessible to their user communities. If they baseline monitored files and data structures any time after a system has “gone live,” it is possible that the system has already become compromised and the integrity checker will miss changes that have already occurred.

### 8.2.5.3 Analyst Tools

Many intrusion detection and vulnerability scanning tools described above and in previous sections of the Framework come with their own rudimentary analysis tools. Some third-party vendors offer tools that will input security audit logs and intrusion event logs from some systems for further analysis, particularly if they have been generated in some standard format (e.g., open database connectivity). The interoperability standards for some of these formats (intrusion detection in particular) are still under development in standards bodies and government-sponsored activities such as the Defense Advanced Research Projects Agency (DARPA) Common Intrusion Detection Framework (CIDF) program, the Internet Engineering Task Force’s (IETF) Intrusion Detection System Working Group, and the ISO SC27 standards group.

## Technology Overview

While network and host sensor technologies have been developed specifically for detect and respond functionality, analyst tools have evolved from more general-purpose applications. Although basic tools and technologies exist, commercial analyst tools have not generally been tailored to this environment. We note that the government sector (e.g., the Intelligence Community) has developed a number of custom tools that more closely relate to this use; however, they are considered beyond the scope of the discussion in this Framework.

To support the analyst in performing the functions described in Section 8.2.4, Detect and Respond Functions, tools and techniques must be assembled that allow analysts to use all aspects of the information analysis technologies discussed below across the problem. The kind of tools required to do the “all source” type of analysis required by the detect and respond infrastructure are not currently available in the commercial sector, but any analyst tools (individually or in combination) must provide functions in the following areas:

**Data Reduction.** IDSs are notorious for generating large amounts of mostly superfluous information if not configured precisely. Even when well configured, their design is such that the system errs on the side of identifying, tagging, and reporting on all potential intrusion events. This data must be reduced to information of import before any additional analysis steps can be performed. Often, data reduction takes place incrementally during many of the analyst functions described in Section 8.2.4, Detect and Respond Functions. Models of “acceptable behavior” are typically used to reduce information. Local knowledge, such as configuration of the networking environment, knowledge of the application and systems in use across the network or enclave, and the expected traffic patterns of normal behavior, can all be used to reduce the mass of information generated by these systems to more manageable and germane levels.

**Data Correlation.** Correlation of events over a large set of data, even after data reduction techniques have been applied, to identify problems or determine if attacks are under way can be time-consuming and place extreme demands even on experienced operations staff. The larger the correlation environment, the more complex and detailed such correlations become. Often, operations staff cannot keep up with the increasing rates at which events are generated. Therefore, automated event management and correlation systems that can scale to large and complex environments are needed to accurately model and store the diagnostic knowledge possessed by operations staff. They must provide algorithms that analyze this knowledge in the context of the current system state to detect problems as they occur. Such systems must be able to input and correlate data from disparate sources, from intrusion detection event data to external alerts and intelligence databases. Generally, automated correlation tools determine relationships among data by implementing one or more of the following reasoning techniques: rule-based reasoning (RBR), model-based reasoning (MBR), state transition graphs (STG), codebooks, and case-based reasoning (CBR).

RBR techniques may not be well suited to larger, enterprise-wide environments but can work well in small domains, perhaps on the local level. Codebook reasoning is faster than rule-based reasoning given its streamlined encoding methodology and is better suited for larger enterprise environments. STG techniques are limited to correlated events in a single object and cannot

determine when problems occur across related objects. MBR also does not function well in large domains, and CBR does not scale well because of the need for a general case library, which would be different for each enterprise/local environment. A scaled approach based on these techniques has yet to be developed.

**Data Mining.** Data mining refers to capabilities to drill down through a database and display information in a meaningful way. It is one segment of the broader knowledge discovery technology that addresses knowledge creation overall. Data mining technology and techniques can be applied to the analysis environment with the goal of turning information from all sources in the detect and respond infrastructure into the identification of hidden attacks, patterns of attacks, and prediction of attacks. Data mining technologies can potentially discover hidden predictive information in large data sets. They use knowledge discovery, pattern recognition, statistical data analysis, and database systems technology to automate the search for information in data sets. Data mining technologies collect and analyze information from multiple data sets and check them for data integrity. They provide a clearer resolution of the information, provide an understanding of attacks in progress, and predict patterns of attacks.

Some specific work is already under way at Columbia University, where researchers have defined and tested a data-mining framework for adaptively building intrusion detection models. Their work uses auditing programs to extract information to detail each network connection or host session. Then they apply data mining techniques, such as classification, meta-learning, association rules, and frequent episodes to learn rules that accurately capture the behavior of intrusions and normal activities. These rules can be used to build new detection models. While this is only part of the solution, it illustrates how data mining techniques are becoming an integral aspect of a more advanced detect and respond tools base.

**Visualization.** Data visualization cuts across all the aforementioned areas. Technologies must be employed that make use of simple, yet effective visualization techniques to assist the analyst through the various functions associated with the framework. The use of common metaphors and design elements provide the ability to visually process presented information effortlessly. Gestalt principles of proximity, continuity, similarity, symmetry or good form, and closure, as well as the introduction of appropriate perspective and relevant color, all significantly enhance the analysis functions.

## Considerations for Their Selection, Deployment, and Operation

All the above factors must come together in a tool or series of technologies that provide to the analyst the ability to support the detect and respond infrastructure as described in Section 8.2.4, Detect and Respond Functions. Numerous tools exist that provide partial solutions, but there are still many challenges relating to common data export formats, the development of accepted reference models, and the problem of all-source data fusion that allow a focus on attacks versus incidents.

These technologies become of critical importance in the context of an overall enterprise management strategy, particularly as it pertains to detect and respond operations. Today, many event management functions are handled manually. Analysts and operators monitor and



correlate events and handle identified problems (or potential problems). This manual processing does not scale to the growing speed, complexity, and size of many enterprise networks. Using these technologies, an enterprise management capability can accurately model and store diagnostic knowledge possessed by operations staff and provide algorithms that use this knowledge in the context of the current system state to monitor, detect, characterize, and react to events in an efficient and effective manner.

Essentially, all these technologies must—

- Operate on a common data/information format. Given the nature of the tools required and the information to be processed, some sort of data warehouse construct is probably the most viable approach.
- Provide different levels of functionality at different tiers of the framework. Some tool functionality, such as the requirement to integrate event information with intelligence data, will not be required at a local level but will be necessary at the organizational and national levels, particularly where coordinated attack determination analysis is under way.
- Provide seamless operator interfaces between technologies and a common, yet flexible, visualization approach.

There are no commercially available tools that provide all the necessary functions to satisfy the analysis needs within the detect and respond infrastructure. While there are fusion tools that have been developed within the government that provide functions similar to those needed for the detect and respond environment, they do not synergistically bring together various analysis technologies in a single packaging for this specific focused purpose. For the most part, they have evolved and have been tailored for specific community (e.g., warfare and intelligence) operations. In some cases, there are efforts under way to adapt them to the detect and respond environment; however, they have not reached the state of commercial technology offerings. Simple commercial off-the-shelf (COTS) approaches will undoubtedly require tailoring and integration efforts to build a cohesive shell or framework system around the various critical technologies.

## 8.2.5.4 Response Tools

There are two general classes of response tools considered within this Framework. One is a deception server, as discussed below. The second class of response tools, referred to as active countermeasures, focuses on implementing immediate mitigation actions to repel or redirect active attacks to minimize damage or reestablish and recover blocked or disabled services.

### Deception Servers

These response tools provide capabilities for characterizing and refining information pertaining to attacks in progress or particular attackers either by redirecting or luring attackers into highly instrumented system infrastructures designed to closely audit all activities. These systems are

typically called deception servers, although they are more commonly known as honey pots, fishbowls, and upon occasion, Venus flytraps.

## Technology Overview

The concept behind deception servers is to present a “false” front, an instrumented server environment, with simulated well-know vulnerabilities (the honey pot construct) to lure attackers in with the promise of an easy score. These systems are designed and configured to emulate a production environment but are in reality set up to alert network administration and security staff while at the same time generating detailed activity logs of the attack or intrusion event. The system thoroughly measures and tracks the would-be intruder’s activities.

While not a new idea, this is a relatively new class of product to be offered commercially. These products are capable of simulating a range of different network servers and devices to act as an attractive decoy for the would-be attacker. While the attacker concentrates on the decoy services, the honey pot collects as much evidence as it can while it is alerting the administrator.

When an incident is detected it is the organization’s choice to terminate the connection immediately or to continue to allow the attacker to explore the façade system. If the connection is terminated, the attackers know that they have been detected and may try a different approach or to attack a different organization with the same attack. If allowed to continue unchallenged within the deception environment, information about the attacker can be gained. This information can be recorded and used by law enforcement officials to apprehend the attacker and take suitable legal action.

Deception servers can be useful only if the environment being protected has sufficient resources to use them once they are deployed.

## Considerations for Selection Unique to the Deception Server Environment

Besides the usual criteria for selection of any software package or technology to be used within the Framework, such as supportability, dependability, clarity of user interface and documentation, ease-of-use and the like, there are a few fairly unique aspects to consider. There are a number of considerations that should be taken into account when choosing a deception server product for deployment.

**Platform and Emulation Operating System.** The most important factor to consider is platform support. The system should either run on the same type of platform that is commonly used in the environment it will be protecting, or emulate the operating system that is running on the true production systems that surround it. Depending on the target environment, Windows NT and various versions of UNIX should be supported. Some products will even attempt to emulate network appliance services such as Cisco Internet Operating System (IOS).

**Commercial Product versus “Home Grown”.** There are numerous documents available in the community that describe how to configure a deception server from base operating system

## UNCLASSIFIED

Detect and Respond as a Supporting Element  
IATF Release 3.1—September 2002

installations. This could be considered as a cost savings option, particularly if there are operating system support personnel available. However, it may be much more efficient to simply use one of the available products “out of the box.”

**Emulation Level.** Some deception servers attempt to emulate more commonly offered network services while others emulate the application level. The closer the emulation to the true implementation, the more likely the ruse will work without alerting the attacker to the deception. One available technology actually makes a copy of your production system environment, securing it and instrumenting it on a second hardware platform for deployment as a deception server. Those systems that only emulate at an application level are susceptible to network-level operating system (OS) identification tools, such as the commonly used Nmap. The level of deception required depends upon how high the risk factors are for the environment and the probability of threats coming from highly sophisticated attackers. For environments with few resources, easily deployed, commercially available emulation packages should suffice. However, for the best coverage, a full-blown dedicated system that imitates the production environment in every way will provide the best protection possible.

**Reporting and Logging.** Of course, the depth and breadth of logging are important, particularly based on what the true operational goals of the deception server are. If the goal is to simply be alerted to the fact that an intrusion is under way and provide some level of data to assist in the foiling of the intrusion and recovery, the level of audit and reporting need not be particularly high. However, if the goal is to provide sufficient evidence to law enforcement officials to trace and potentially prosecute an attacker, a higher level of audit, reporting, and supporting documentation are required.

## Considerations for Deployment and Operation

There are a number of considerations for deployment and operation of deception servers.

**Placement on the Network and Redirection.** Several methods exist for placing deception servers into a network infrastructure and ensuring attackers go after it. For example, one can either set up boundary routers or firewalls to redirect nonproduction services (e.g., File Transfer Protocol [FTP] or Telnet) to the deception servers rather than to just not support them, and then route normal services, such as HTTP, to production systems. The drawback, of course, is that if attacks take place using production services, the deception server provides no added value. Another approach is to place a deception server at the same logical network level as production servers and have it emulate full production services, so it can become targeted in attack “sweeps.”

**Legal Issues.** Little or no legal precedence has been established for deception servers. If deception servers are deployed, some potential liabilities could be experienced. It would be wise to post the same restricted use notifications that are found on the enterprise’s true production systems. Additionally, be prepared that if the deception server is compromised and then subsequently used as a stepping off point for attacks elsewhere, the organization that deployed the deception server could be found culpable, more so than if their normal production servers were compromised despite due diligence efforts. It should be kept in mind that deception servers

are detection tools and should be treated as such, and unless the deploying organization is a law enforcement agency, unfair entrapment charges cannot really be made successfully.

## Active Countermeasures and Recovery Tools

Active countermeasures and recovery tools focus on terminating the intrusion or attack and restoring affected services or lost data as soon as possible. Recovery may also include initial (technical) damage assessment tools that ascertain the extent of the damage inflicted during the intrusion or attack. These should be differentiated from attack investigation tools, which are used to gather information about intrusions with the intent, among other activities, to trace, locate, apprehend, and prosecute intruders and attackers (addressed in subsequent sections).

## Technology Overview

**Reconfiguration, Containment, and Disconnection Technologies.** There are numerous approaches to initiating active countermeasures that serve to halt or block attacks that are discovered against an environment. Typically, there are no tools one can acquire that stand alone and are used to repel attacks. Most countermeasures come bundled with IDSs. They provide either a standalone capability (e.g., the ability to send TCP disconnects to certain active connections determined to be the source of attacks), have programmed interfaces to network equipment (switches, hubs, routers, and firewalls) so certain connections can be cleared or blocked at the network level, or allow new filtering rules to be instituted based on addressing or protocols associated with the attack. Many tools allow the creation of precanned scripts that can be executed causing dynamic reconfigurations across the enterprise.

Additionally, some host-based tools provide the ability to interface with the host operating system to allow quick disabling of accounts that are being used as launch points for attacks. Dynamic access control modifications are also possible. All these tools should be focused on minimizing the period in which the attack takes place, and consequently minimizing the damage, either from the original attack or as the intruders attempt to cover their tracks as they back out.

These tools (or more appropriately features of available intrusion detection tools) must be chosen carefully and their use within the secure infrastructure planned accordingly. Each of the various attack mitigation features should be thoroughly tested to ensure that they do not wreak more havoc on the enterprise than the original attack. Some tools allow the automatic institution of countermeasures. It is recommended that automatic “shunning” not be implemented until all scenarios are tested and sufficient operational experience in the particular environment indicates the risks are minimal.

**Recovery Tools.** Damage assessment and recovery tools include disk repair and recovery tools as well as operating system specific tools that are able to make repairs to OS-specific data structures on the system (e.g., the Windows registry). It is important to prepare these tools ahead of time, in anticipation of having to recover from attacks, because no protection features are foolproof.

Backup recovery tools are an important component of this part of the framework. Each set of tools must be chosen to work with the particular platforms and information system applications running within the enterprise. Preevent planning and rehearsals should be conducted to ensure that the tools are configured appropriately and operations personnel are sufficiently trained. Processes and procedures for proper backup execution, testing, and the selection of the appropriate periodicity to execute backups are all critical factors in the preplanning phases of recovery operations. Some of the file integrity checking tools addressed in Section 7.2.4, Host Scanners—File Integrity Checkers, can also be used in the recovery process, determining which files may have been corrupted during the attack and may have to be restored from protected media. Besides the technology, appropriate planning is an absolute necessity as part of any response capability.

### **8.2.5.5 Attack Investigation Tools**

Also referred to as computer forensics tools, attack investigation tools, and computer forensics science in general, focuses on acquiring, preserving, retrieving, and presenting information associated with illegal intrusion activities. Three roles of a computer within a criminal context have been identified. The first is where the computer is a target of an attack or intrusion. The second is where a computer is the used as an instrument of an attack (a hacker's computer, for instance). The third is where a computer may be a repository for information pertaining to the commission of a crime, containing databases, images, etc.

In the context of the detect and respond infrastructure, attack investigation or forensics tools consider the first and second roles. The first, where the computer is the subject of the attack, and the second, where a third-party computer is attacked and usurped, then used in subsequent attacks on other systems. The aspect of seized computers being examined for their role in criminal activities, whether as a tool or as a repository, is beyond the scope of this section of the Framework.

### **Technology Overview**

There are three general phases to any computer forensics process: acquisition, examination, and utilization, and consequently different tools for each. In the acquisition phase, information must be acquired from the systems that have been intruded upon and/or attacked in such a way that all the information on the system is captured. In situations where criminal prosecutions are a goal of the investigation, the information must be collected and maintained consistent with rules of evidence. In the examination phase, appropriate tools must be used to analyze the information on the system with the intent of attempt to ascertain such facts as—

- How the attack was achieved (i.e., what vulnerability, technical or procedural, was exploited).
- What information the intruder may have left behind to implicate himself or herself (e.g., trace logs, malicious code or Trojan Horse software, trademark methods, system damage).

- What the intent of the intruder was (e.g., exploration/curiosity, malicious damage, information theft, denial of service, service theft).

Finally, the utilization phase of the forensics process allows for the creation of formal reports, the certification of the chain of custody thread, and all other aspects that then allow the pursuit of a criminal investigation leading to a potential prosecution.

Most standard computer forensics tools focus on the preservation of evidence, the analysis of information for criminal activity, and then the final packaging for prosecution. In the detect and respond infrastructure, while many of these tools have applicability, additional analysis tools that focus on log and event analysis are also important. Of particular importance are those logs and events from secondary systems such as routers and firewalls and not necessarily just the pilfered target system itself. However, in all cases, rules of evidence must be followed to support successful prosecutions.

When a situation arises in the detect and respond environment where attack analysis is intended to potentially lead to criminal prosecution, acquisition tools that capture and preserve the evidentiary trail of information must be used instead of simple log or event information capture and copying. Tools that make exact, certifiable copies of information and often entire disk images must be deployed.

For analysis, tools that not only attempt to recover lost or deleted information (an intruder covering his/her “tracks”) must be deployed, but tools that analyze log events and audit information to build a profile of how an intrusion progressed must also be applied. If necessary, tools that can analyze down to individual TCP/Internet Protocol (TCP/IP) segments and datagrams (TCPdump) must be used along side the more traditional computer forensics tools.

Finally, tools that generate reports, document the chain of custody, and just generally provide additional efficiency, fill out the third phase, utilization.

## Considerations for Selection and Operations

There are a number of factors associated with attack analysis that should be considered when pulling together a stable of appropriate tools.

**Ease of Use and Integration.** A clean, robust user interface, particularly in the complicated analysis phases of an investigation, is critical. Many tools handle all aspects of attack investigation (acquisition, analysis, and utilization) in complete packages, most focused on computer crime scene investigation. It is important to consider if these all-in-one packages adapt easily to the operational environment in question. Also, in most cases, a long, drawn-out investigation will have prohibitive impact on operations. The speed with which information can be collected for later analysis is critical.

**Preservation of Evidence.** The tools must preserve evidence appropriately, per acceptable law enforcement or prosecutorial standards. The disk copying or information copying tools must

function in such a way as to ensure a perfect copy is preserved. The available tradeoffs between speed and copy perfection (full image versus information copy) must be determined.

**Flexibility.** The tools must be able to collect, preserve and analyze information from the systems deployed in the local environment.

**Operational Approach.** The available tools are still in focused mostly on single activities, such as information capture or disk imaging, log analysis, the discovery of deleted files or hidden information. Consequently, particularly in a detect and respond situation, a well-composed investigative framework must be established ahead of time to provide the context for the implementation of the tools. The functions during an investigation are described in Section 8.2.4.9, Functions to Support Attack Investigation, but the next level of detail appropriate to the particular environment in question, such as operations personnel availability, budget, local and/or national policies on how long systems can remain off-line for investigation purposes, etc., all must drive the particular tool acquisitions.

## 8.2.5.6 Related Detect and Respond Operational Considerations

While there are a number of technologies available to support various aspects of detect and respond, there are also important considerations that deal with their selection, deployment, and operation. Some of these are discussed below.

### Independent Testing of Technologies

Another factor slowing the development of these technologies is the lack of adequate testing and product certification facilities. Large-scale testbeds are needed to test these systems using real-world simulations and to develop metrics, verification procedures, and standard test-case scenarios. There is a real need for independent laboratories to evaluate and certify products, providing unbiased and accurate evaluations of relevant technologies that can be made available to network security customers.

The National Security Telecommunications and Information Systems Security Policy (NSTISSP) No. 11 provides the national policy that governs the acquisition of IA and IA-enabled information technology products for national security telecommunications and information systems. This policy mandates that effective January 2001 preference be given to products that are in compliance with one of the following:

- International Common Criteria for Information Security Technology Evaluation Mutual Recognition Arrangement.
- NSA/National Institute of Standards and Technology (NIST) National Information Assurance Partnership (NIAP).
- NIST Federal Information Processing Standard (FIPS) validation program.

After January 2002, this requirement is mandated. DoD Chief Information Officer (CIO) Guidance and Policy Memorandum No. 6-8510, *Guidance and Policy for Department of Defense Global Information Grid Information Assurance* references this same NSTISSP No. 11 as an acquisition policy for the Department.

The International Common Criteria and NIAP initiatives base product evaluations against Common Criteria Protection Profiles. NSA and NIST are working to develop a comprehensive set of protection profiles for use by these initiatives.

## **System Backup**

There are two main strategies to follow when performing a system backup: one for the workstation level and the other for the network level.

### **Workstation Strategy**

The best backup strategy for workstations is to back up often. If the workstation is running the Windows OS, there are some simple backup tools already provided. There are also several utilities and programs available from reputable companies to aid users in performing backups. The following features can make backup chores more bearable: incremental backup, unattended scheduling, and easy, simple restoration. Incremental backup saves changes made since the most recent full or incremental backup. This is important because users who do not want to wait to back up a system can use incremental backup as a substitute for a lengthy full backup. Scheduling uses software automation to execute backup chores without the need for personal interaction. While the user must select and put in place a backup media, the user does not need to be present for the actual backup. Zip© drives and small tape drives are also cost-effective solutions used to back up workstation data.

### **Network Strategy**

The best backup strategy for networks is an approach that combines several features to save time and effort and still ensure complete backups. Execute full backups often. Since backups take up network, server, and/or workstation resources, it is best to run full backups when none is working. Also, open files are skipped during backup and do not get backed up at all until some future time when the file is closed and not being used. Having few to no users holding files open will ensure the greatest backup saturation possible. Full backups are most efficiently executed in the evenings. Store the full backup tape off-site. On each of the remaining workdays of the week, using a separate tape for each day, run an incremental backup and store it off-site, too. The last full backup of the month should be permanently moved off-site and held for archival purposes. If a network is attacked by malicious code, these backup techniques will ensure data integrity and allow all systems to be recovered.



## Security Awareness Training

Security awareness is usually a first line of defense for an organization. Organizations should implement a security awareness training program sanctioned by a recognized information systems security authority such as NIST. An acceptable security program should be able to inform users about the threats of e-mail attachments, simple physical security, and protection of authentication mechanisms. The threats are much more numerous than these examples but statistical information indicates most users know very little about these threats.

## Configuration

Proper system administration is one of the best mechanisms to limit the number of vulnerabilities that can be exploited. CERT and other organizations publish vulnerabilities and fixes for those vulnerabilities. Every organization should be aware of the latest security patches and fixes for their equipment.

## Privacy Concerns

Organizations may own the intellectual property of employees and may also legally restrict computer activities to only those approved by management. A common practice is to present this warning to all computer users as part of the normal login message. This does not mean that all managers in an enterprise own all of the transactions of all of the employees. Especially unclear is how to handle the conflict that arises between privacy and monitoring. Use of IDSs and system-monitoring tools requires caution. Legal issues pose a potential problem to the deployment and use of detect and respond technologies. As noted in NTIB#1, legal and regulatory issues are very complex and the “legal system has not yet made authoritative judgments on the issues.” The report illustrates the conflicting views on the subject noting that “intrusion detection systems are sometime viewed as intrusive themselves, and . . . the position is taken that all information systems are subject to arbitrary monitoring at any time.”<sup>3</sup>

Sniffers that search for key words in messages (e.g., “attack,” “weakness,” or “confidentiality”) as a standard set of watchwords may find key words used in an appropriate manner depending on the type of correspondence. Audit trail reports may contain full command strings (including parameters). The results of an analyst’s investigation of traffic patterns or traffic content within or interfacing to an enterprise (either in response to a possible intrusion or during an investigation following an attack) could be considered an unwarranted invasion of privacy. Activating and directing a potential adversary to a honey pot (deception server) raises privacy issues as well. It is important to refer privacy concerns to the appropriate legal and policy organizations for the enterprise prior to deployment and use of these technologies.

---

<sup>3</sup> “National INFOSEC Technical Baseline—Intrusion Detection and Response,” Lawrence Livermore National Laboratory and Sandia National Laboratories, December 1996, as reported in Network Intrusion Detection and Response, a Technology Forecast, by William L. Cameron, AlliedSignal Technical Services Corporation, August 1998.

## 8.2.5.7 Technology Reference Model

As discussed earlier in this section of the Framework, the detect and respond infrastructure is hierarchical by its nature. There is a tight coupling between the physical structures (of the local computing environment, enclave boundary, and system infrastructures), the processes that need to be performed, and the technologies that are available to realize those processes at each layer of the hierarchy. A technology reference model for this system infrastructure highlighting these relationships is provided in Figure 8.2-17.

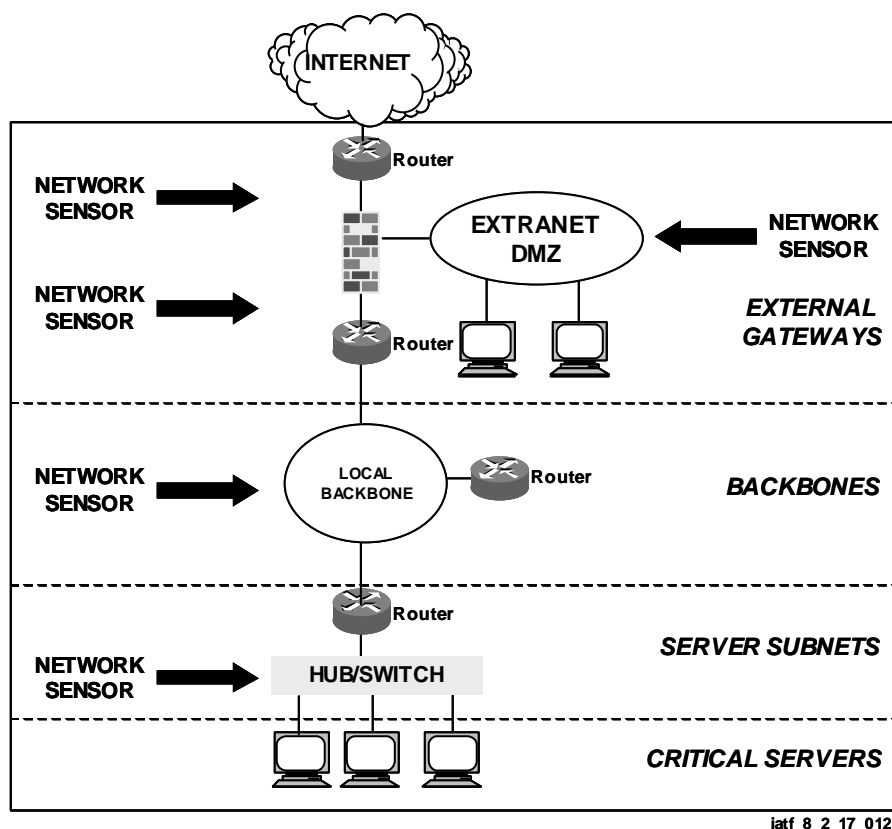

**Figure 8.2-17. Detect and Respond Technology Reference Model**

The shaded areas of the figure represent a typical local environment (computing environment and enclave boundary). As discussed in earlier sections, the local environment is the natural location for host and network-based sensors (e.g., IDSs and vulnerability scanners). If detect and respond technologies (e.g., honey pots) are used, they are also located at this level of the hierarchy.

The processing above the sensors can be placed at every level of the hierarchy. Local environments have the option of deploying any and all aspects of processing and analysis, usually focused for their specific operations. Similar structures may also be available to focus at organizational, enterprise, and national levels. There is a decision making capability needed at each level to interpret the operational implications of current situations and provide direction on

courses of actions. This is typically performed with some collaboration at levels higher and lower as appropriate.

The network infrastructures that typically connect local environments together also provide the basic connectivity of these environments to various elements of the detect and respond infrastructure. This connectivity is needed to provide reporting up the hierarchy and information associated with response coordination back down.

The very nature of the reference model highlights the importance of selecting technologies that can interoperate with each other across the overall detect and respond infrastructure. Although not shown, to realize a system infrastructure that can deal with an appreciable sized enterprise, that integration should extend into the system and network management infrastructures as well.

## 8.2.6 For More Information

The list of reference materials used in preparing this section provides an excellent base of knowledge from which to draw on relevant technologies. There are a number of additional sources of information. This section of the Framework focuses on on-line sources because they tend to offer up-to-date information. These include the following:

### IA Technology Framework Executive Summaries

An important segment of the IATF is a series of executive summaries that are intended to provide summary implementation guidance for specific case situations. These offer important perspectives on the application of specific technologies to realistic operational environments. These are still being formulated and will be posted on the IATF Web [site http://www.iatf.net/](http://www.iatf.net/) as they become available.

### Protection Profiles

The International Common Criteria and NIAP initiatives base product evaluations against Common Criteria Protection Profiles. NSA and NIST are working to develop a comprehensive set of protection profiles for use by these initiatives. An overview of these initiatives, copies of the protection profiles, and status of various products that have been evaluated are available at the NIST Web site <http://niap.nist.gov/>.

### 8.2.6.1 Independent Third-Part Reviewers of Relevant Vendor Technologies

- ICSA Net Security Page, [www.icsa.net](http://www.icsa.net)
- Talisker's Intrusion Detection Systems, [www.networkintrusion.co.uk/](http://www.networkintrusion.co.uk/)
- Network Computing—The Technology Solution Center, [www.nwc.com/1023/1023f12.html](http://www.nwc.com/1023/1023f12.html)

- Paper on CMDS Enterprise 4.02, <http://www.Intrusion.com/Products/enterprise.shtml>  
(ODS Networks has changed its name to Intrusion.com)
- PC Week On-Line, [www.zdnet.com/pcweek/reviews/0810/10sec.html](http://www.zdnet.com/pcweek/reviews/0810/10sec.html)

## 8.2.6.2 Overview of Relevant Research Activities

- Coast Homepage—Perdue University, [www.cs.purdue.edu/coast](http://www.cs.purdue.edu/coast)
- UC Davis, [seclab.cs.ucdavis.edu/](http://seclab.cs.ucdavis.edu/)

## 8.2.6.3 Overview of Selected Network Monitor Vendor Technologies

- Symantec Corporation, <http://www.symantec.com>
- Cai.net, <http://www.cai.net/>
- Cisco Connection Online, [www.cisco.com](http://www.cisco.com)
- CyberSafe Corporation, [www.cybersafe.com](http://www.cybersafe.com)
- Internet Security Systems, [www.iss.net](http://www.iss.net)
- Network ICE, [www.networkice.com](http://www.networkice.com)

## UNCLASSIFIED

Detect and Respond as a Supporting Element  
IATF Release 3.1—September 2002

### References

1. Information Assurance Technical Framework (IATF), <http://www.iaf.net>.
2. National Institute of Standards and Technology, <http://niap.nist.gov/>.

### Additional References

- a. Amoroso, Edward, *Intrusion Detection*. Intrusion.Net Books. 1999.
- b. Symantec Corporation. *Intruder Alert 3.5 IDS Review Guide*. May 2000.
- c. Symantec Corporation. *Everything You Need to Know About Intrusion Detection*. 1999.
- d. Balasubramanian, J. S., et al. *An Architecture for Intrusion Detection Using Autonomous Agents*. COAST Technical Report. 11 June 1998.
- e. Concurrent Technologies Corporation. *Attack Sensing, Warning, and Response (ASW&R) Trade Study Report Intrusion Detection System*. Report No. 0017-UU-TE-000621. April 14, 2000.
- f. Concurrent Technologies Corporation. *Attack Sensing, Warning, and Response (ASW&R) Baseline Tool Assessment Task Anti-Virus Trade Study Report*. Report No. 0017-UU-TE-000623. April 13, 2000.
- g. Department of Defense (DoD) Chief Information Officer (CIO) Guidance and Policy Memorandum No. 6-8510, *Guidance and Policy for Department of Defense Global Information Grid Information Assurance*.
- h. Escamilla, Terry. *Intrusion Detection, Network Security Beyond the Firewall*. Wiley Computer Publishing. 1998.
- i. Graham, Robert. "New Security Trends for Open Networks." *SC Magazine*. October 1999.
- j. Information Assurance Technology Analysis Center (IATAC). *Tools Report on Intrusion Detection*. Defense Technical Information Center. December 1999.
- k. Information Assurance Technology Analysis Center (IATAC). *Tools Report on Vulnerability Analysis Information*. Defense Technical Information Center. March 15, 2000.
- l. "Intrusion Detection." *SC Magazine*. June 2000.
- m. Maes, V. "How I Chose an IDS." *Information Security Magazine*. Volume 2, Number 9. September 1999.
- n. National Security Telecommunications and Information Systems Security Policy (NSTISSP) No. 11. *National Policy Governing the Acquisition of Information Assurance (IA) and IA-Enabled Information Technology (IT) Products*. January 2000.

## UNCLASSIFIED

Detect and Respond as a Supporting Element  
IATF Release 3.1—September 2002

- o. Northcutt, Stephen. *Network Intrusion Detection, An Analyst's Handbook*. New Riders Publishing. 1999.
- p. Schneider, Sondra, et al. "Life After IDS." *Information Security Magazine*. Volume 2, Number 9. September 1999.
- q. Snapp, Steven R., et al. *A System for Distributed Intrusion Detection*. IEEE CH2961-1/91/0000/0170. 1999.
- r. Ulsch, Macdonnell and Joseph Judge. "Bitter-Suite Security." *Information Security Magazine*. Volume 2, Number 1. January 1999.

**UNCLASSIFIED**

Detect and Respond as a Supporting Element  
IATF Release 3.1—September 2002

**This page intentionally left blank.**

## Chapter 9

# Information Assurance for the Tactical Environment

---

Communicating urgent, time-sensitive, or life-and-death information over wireless links in a military or quasi-military tactical environment presents unique information assurance (IA) challenges. This section addresses the specific security concerns associated with tactical information systems, and points out critical technology gaps in today's tactical communications environment. The section highlights key tactical-specific issues in an effort to generate credible IA criteria, resulting in a significant and positive impact on IA technology developed by industry.

The first part of this section focuses on a description of the tactical environment and the types of threats specific to this environment. The latter part of this section covers several IA issues facing tactical users. Current and anticipated requirements for IA solutions are drawn from these issues. Finally, each section identifies current technologies in development or production that may satisfy key IA requirements, provides framework guidance on recommended technologies, and identifies substantive gaps in available security solutions. This insight will help guide United States (U.S.) industry in developing security technologies to satisfy the needs of tactical users. It also will assist government users in understanding the range of security solutions available and the manner in which these solutions might be used.

Although some of the key technologies discussed here may have been mentioned in previous sections of the Information Assurance Technical Framework (IATF), the unique requirements of the tactical environment warrant a separate discussion for the benefit of equipment developers, integrators, and warfighters. This section focuses exclusively on those issues in which the tactical environment presents unique requirements for IA technologies. Tactical users should refer to other sections of this IATF for guidance on common IA technologies such as firewalls, virtual private networks (VPN), and intrusion detection systems.

This chapter of the IATF will be useful to the following types of organizations.

- U.S. Department of Defense (DoD) and commercial engineering support organizations responsible for design, integration, and life cycle support of tactical communications and information processing equipment.
- Military and other DoD organizations involved in conducting tactical operations.
- Other nonmilitary organizations involved in tactical operations (e.g., law enforcement; Alcohol, Tobacco, and Firearms [ATF]; Drug Enforcement Agency [DEA]; the Coast Guard; emergency responders; search and rescue units; Immigration and Naturalization Service [INS]; and other agencies involved with National Security and Emergency Preparedness [NS/EP] communications).



- Anyone whose operations are mobile or who has heavy reliance on urgent, time sensitive, or life-and-death information often communicated over radio frequency (RF) links.

## 9.1 Target Environment

### Definition of Tactical

In this context, tactical communications refers to a set of systems, products, and infrastructure that transfer time- and content-sensitive communications between wireless nodes, or from wired to radio transmission environments. These systems are used typically in military-style operations and require specific frequency allocation and spectrum management to avoid electromagnetic interference with commercial and civil communications.

The following set of characteristics is used to define tactical.

- Military-style operations.
- User-owned (or leased) equipment and infrastructure.
- Radio communications in licensed frequency bands.
- Communications in a hostile physical and RF environment.
- Classified or Unclassified but Controlled communications.
- Time-sensitive communications.

Because of the unique nature of the tactical environment, certain types of attacks are more common than others. Previous sections of this framework divide attacks into four categories: passive, active, insider, and physical and distribution. Tactical forces place a high degree of trust in individual unit members and in the communications systems available for their mission. However, as the information transport network in tactical environments is often RF based, the potential still exists for an adversary to gain access to internal tactical communications systems, masquerading as an authorized user. The adversary then has the potential to conduct an insider attack. Thus, tactical communications systems must also defend against these types of attacks.

A majority of tactical communications systems are subject to both passive and network attacks by highly sophisticated adversaries, often with abundant resources. Although not a tactical site attack, the recent Kosovo conflict demonstrated an increase in the sophistication of our adversaries. Individuals sympathetic to the Serbian forces attacked several U.S. and North Atlantic Treaty Organization (NATO) Web sites. Although most of these were denial of service attacks against publicly accessible Web pages, more complex and malicious attacks can be anticipated in future conflicts.

As noted in Section 5.2, Wireless Networks Security Framework, commercial wireless users and service providers are often concerned with theft of service attacks. However, tactical users of wireless communications systems are concerned with more destructive attacks threatening lives, or the national security, or both. Specific attacks that many tactical users want to prevent are as follows:

- Geo-location (determining location of operators, confidentiality).
- Detection and interception of communications traffic (confidentiality).
- Jamming communications traffic (denial of service).
- Communications traffic analysis (gathering knowledge of activities from patterns of communications usage).
- Network intrusion and associated masquerading attacks (integrity, false message insertion, and password sniffing).
- Theft of sensitive/classified information (confidentiality).
- RF fingerprinting (association of a particular medium with a specific user; i.e. unit identification based on radio characteristics).

## Military Examples

Examples of tactical communications scenarios vary based on the specific missions and military services involved. Figure 9-1 illustrates the complexity of deploying a total-force tactical communications suite to a battlefield. The figure also shows the warfighter’s reliance on key access points (satellite links and Unmanned Aerial Vehicle [UAV] airborne communication nodes) used to access the larger communications infrastructure. Communications architectures for nonmilitary tactical operations can have similar characteristics.

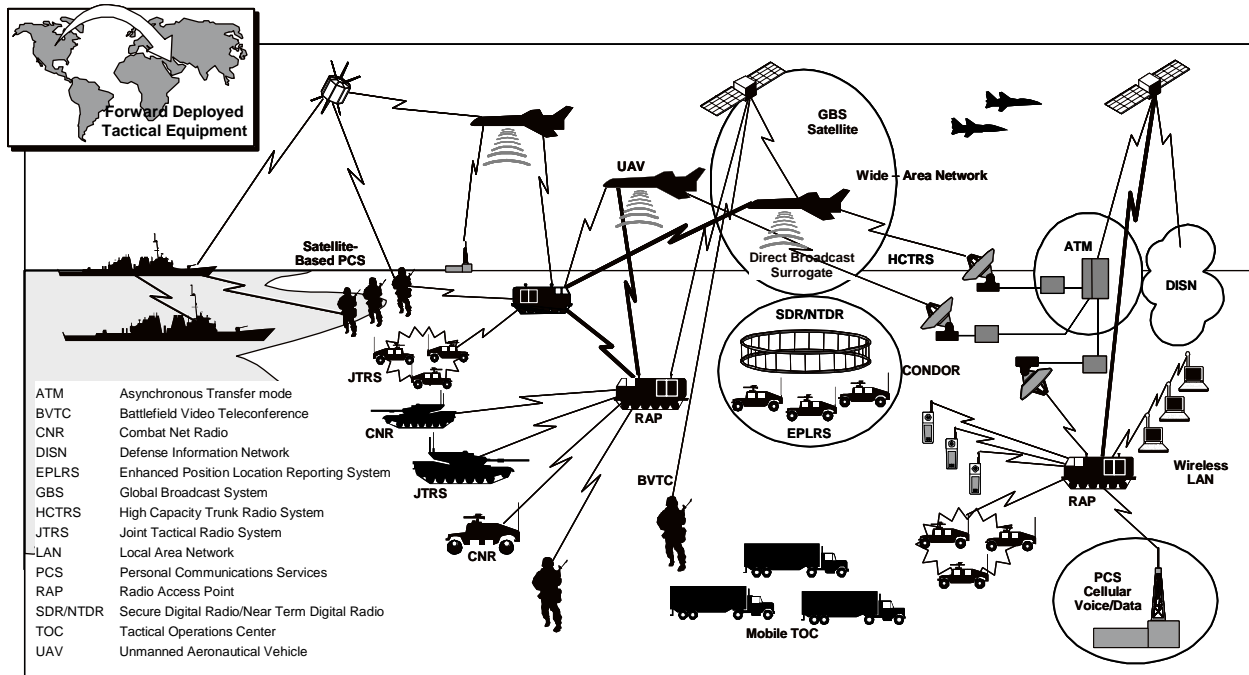

iatf\_9\_1\_0129

Figure 9-1. Tactical Communications Environment

Clearly, not all of the systems shown in Figure 9-1 are interoperable, as the figure might suggest. A majority of current tactical communications have a low degree of interoperability among the military services. However, future systems like the Joint Tactical Radio System (JTRS) will provide increased interoperability among the military services' and allied networks, yielding an increased command and control (C<sup>2</sup>) capability for decision makers.

Figure 9-2 shows the types of information flowing into and out of a typical tactical environment to U.S. command sites. Major operational functions such as frequency management are often handled at a Main Operating Base (MOB) or command center, rather than on the front lines. Other functions provided from Continental U.S. (CONUS) locations include missile warning information from the North American Aerospace Defense (NORAD) Command, and nuclear, biological, and chemical (NBC) fallout tracking from Los Alamos National Lab. These types of information pass back and forth between tactical forces and fixed locations in CONUS. Additionally, critical databases and imagery information are maintained either at the MOB or at the theater headquarters. Tactical units can access information on an as-needed basis, instead of bringing extra equipment to the front lines. Thus, a vast amount of data flows continuously between the main base in CONUS, the forward base, and forces on the front lines in a tactical scenario.

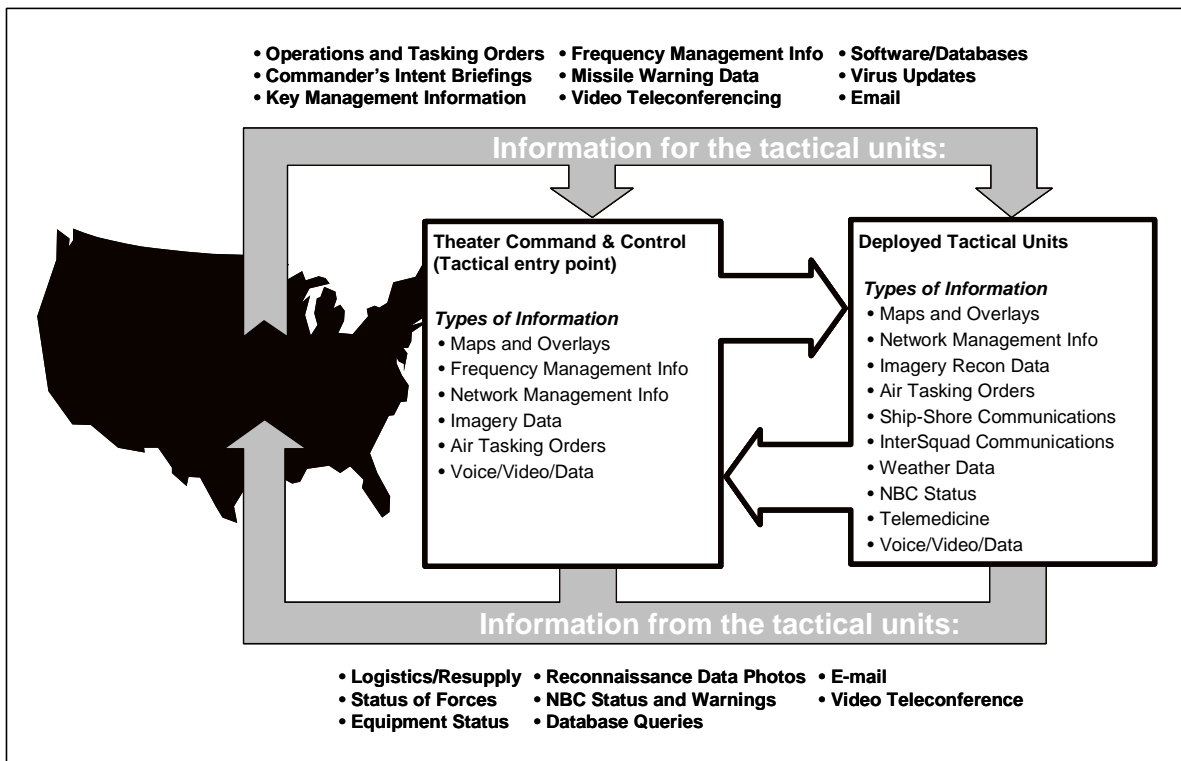

iatf\_9\_2\_0130

Figure 9-2. Tactical Communications Information Flow

Tactical communications are often defined by their environment and purpose rather than the specific equipment in use. In the past, tactical communications equipment was primarily composed of government off-the-shelf (GOTS) equipment. Such unique or “closed” systems,

however, often require extensive support throughout their life cycles. In addition, it is often not cost effective to try to expand their capabilities to meet new requirements. Even with increased government budgets, the need for more capability has outstripped resources. Increased interoperability requirements and faster technological evolution have resulted in the increased use of commercially developed equipment in tactical communications. The trend in today's tactical equipment design is to build open architectures where new advances can be added to systems efficiently.

A key example of DoD movement toward an open architecture is the JTRS. Recently, DoD identified the needs and benefits of combining various radio acquisition programs being proposed by the Services. As a result, DoD proposed the development of a family of affordable, high-capacity tactical radios to provide line-of-sight (LOS) and beyond-line-of-sight Command, Control, Communications, Computer, and Intelligence (C4I) capabilities to warfighters. This family of radios will be capable of covering an operating spectrum from 2 to 2000 Megahertz (MHz) and will be capable of transmitting voice, video, and data. However, the JTRS is not a "one-size-fits-all" solution. Rather, it is a *family* of radios that is interoperable, affordable, and scalable. By building on a common architecture, JTRS will improve interoperability by providing an ability to share waveform software and other design features between radios. The goal is to migrate today's legacy systems to systems compliant with the JTRS architecture. Section 9.8.3, Technology Assessment presents a more in-depth discussion of the JTRS.

The challenge of moving to an open architecture while remaining backward compatible with existing legacy equipment and systems can seem overwhelming. Military systems have traditionally been designed for a specific type of environment, with little regard to future universal interoperability. However, tactical communications systems in the future will be required to interoperate effectively. For example, until recently, two separate devices were required if a commander wanted to place a call on a local cellular system and on a satellite communications (SATCOM) link. Today, a single telephone will operate on both standard cellular and low-earth orbit (LEO) satellite systems. Ideally, this same cell phone can then be integrated into other tactical communications networks like the Mobile Subscriber Equipment (MSE)/Tactical Packet Network (TPN) suite of equipment to maximize the operator's connectivity in the tactical environment, while minimizing the volume of equipment carried. To realize this vision, tactical systems will need to support common signaling plans and protocols such as Internet Protocol (IP) and Future Narrow Band Digital Terminal (FNBDT). Additionally, future systems such as the JTRS will handle multiple frequencies, multiple types of data (voice, data, and video), and multiple waveforms. Warfighters will drastically improve their situation awareness by accessing vital intelligence databases and imagery. Future tactical cellular systems and personal digital assistants (PDA) will allow troops to pull down current satellite images or update enemy locations on the commander's map, giving the commander a better picture of the battlefield. However, these information advantages can be only realized, if the tactical information and communications systems possess sufficient levels of IA.

## Civilian Examples

Nonmilitary organizations also employ systems that meet the tactical communications definition presented earlier. Examples are as follows:

## UNCLASSIFIED

Information Assurance for the Tactical Environment  
IATF Release 3.1—September 2002

- First responders deploying to a terrorist incident.
- Communications support to the Secretary of State during travels.
- Civil departments and agencies deploying to support missions under a variety of operational plans.
- Industry deploying network disaster recovery teams, cellular sites on wheels, and satellite telephone banks into disaster areas, as was the case in 1995 during the Hurricane Marilyn response on St. Thomas, VI.

A particularly interesting example is the new Florida Veterans Mobile Service Center consisting of a 43-foot mobile medical/dental clinic and veterans benefits. The center uses four cellular phone connections, two satellite links, and two laptop computers to link counselors with the state's Department of Veterans Affairs (VA) medical centers and benefits office, allowing them to access veterans' records and medical histories. Videoconferencing equipment allows VA physicians to interview patients directly from the mobile unit.

Probably the best example of nonmilitary tactical operations is the Federal Emergency Management Agency (FEMA) in its role under the Federal Response Plan (FRP) as the coordinator of federal responses to Presidentially declared disasters and emergencies. FEMA coordinates FRP consequence management support to numerous national plans, including the Federal Radiological Emergency Response Plan, the National Oil and Hazardous Substances Pollution Contingency Plan, and the Federal Bureau of Investigation's (FBI) Weapons of Mass Destruction Incident Contingency Plan.

As consequence manager, FEMA is responsible for organizing federal efforts to protect public health and safety, restore essential government services, and provide emergency relief to minimize the effects on the populace of a natural, technological, or terrorist event. To support the various operational facilities and teams that respond in accordance with the FRP, FEMA can deploy telecommunications assets from its six Mobile Emergency Response Support (MERS) detachments located in Massachusetts, Georgia, Texas, Colorado, and Washington and its Mobile Air Transportable Telecommunications System (MATTS) located in Virginia.

MERS and MATTS assets can deploy to a disaster area to support federal, state, and local responders using a variety of communications transmission systems such as satellite, high-frequency, and microwave LOS interconnected by fiber optic cables to voice and data switches, local area networks (LAN), and desktop devices such as personal computers and telephones. Telecommunications can be provided for single or multiple locations within a disaster location. MERS and MATTS telecommunications assets can establish or reestablish communications connectivity with the public telecommunications system or government telecommunications networks and can interconnect facilities within the disaster region.

MERS and MATTS include these telecommunications transmission capabilities:

- Satellite. Ku-band satellite for quick connectivity that provides up to 48 lines for either telephones or data. International Maritime Satellite (INMARSAT) and American Mobile

Satellite Corporation (AMSC) satellite terminals provide immediate single voice channel capabilities.

- LOS Microwave. Microwave transmission to connect to the public network (PN), provide connection to other facilities, or extend communications.
- High frequency (HF) radio to communicate with federal, state, and local emergency centers via the FEMA National Radio Network and FEMA Regional Radio Network.
- Very high frequency (VHF) and ultra high frequency (UHF) radio for local communications.

When deploying in a possible tactical situation, nonmilitary organizations face some of the same IA issues and requirements as DoD. The requirements most important to nonmilitary organizations are interoperability among response elements and protection from the following:

- Interception of communications traffic that is normally unclassified but may be sensitive.
- Denial of service.
- Network intrusion.

## **Layout of the Tactical Communications Section**

To adequately scope the key IA issues facing U.S. tactical forces today, representatives from the tactical community contributed to a list of the leading IA issues to be discussed in this section of the IATF. This list is certainly not all encompassing and may vary in order of importance for different users. However, the issues discussed here will apply to a variety of users and will highlight the IA deficiencies that exist in current systems. Joint and service-specific documents such as Joint Vision 2010 and the U.S. Army Warfighter Information Network document are used as key reference points for many of the tactical issues and requirements discussed in this section of the Framework. Unless otherwise noted, these issues are consistent with the issues described in the Service's forward-looking documents.

The following key IA issues identified by the tactical community are discussed in this section:

- Wiping Classified Data From Tactical Equipment (9.2).
- Stored Data Protection in a Hostile Environment (9.3).
- Key Management in a Tactical Environment (9.4).
- Network Mobility/Dynamic Networks (9.5).
- Access to Individual Classified Accounts by Multiple Users (9.6).
- Secure Net Broadcast and Multicast (9.7).
- IA Solutions in Low Bandwidth Communications (9.8).
- Split-Base Operations (9.9).
- Multilevel Security (MLS) (9.10).
- Additional Technologies (9.11).

## UNCLASSIFIED

Information Assurance for the Tactical Environment  
IATF Release 3.1—September 2002

Within each topic area, a brief overview is provided, followed by a discussion of IA requirements related to each topic. Tactical communications system users have critical equipment and infrastructure requirements beyond what the typical civil or commercial user requires. Anticipated requirements are added in the discussion to highlight requirement areas that will likely need to be addressed for tactical forces five to ten years in the future. These anticipated requirements are based on forward-looking documents such as Joint Vision 2010, the Concept for Future Joint Operations, and the Warfighter Information Network (WIN) Master Plan.

Note that these anticipated requirements should not be considered essential for operations in a tactical scenario. Clearly, warfighters today employ technologies that do not meet many or all of these requirements. Rather, new technologies that incorporate these requirements would be better suited for tactical use than current systems. Thus, development of such technologies will improve the IA inherent in future tactical equipment and systems.

After the requirements discussion, relevant current technologies are addressed. Finally, each topic concludes with a section regarding Framework guidance. The guidance section presents technology recommendations for tactical users and Information System Security Engineers (ISSE), and technology gaps highlight areas for future industry developments.

## **9.2 Wiping Classified Data From Tactical Equipment**

### **9.2.1 Mission Need**

U.S. military forces have been involved in an increasing number of nontraditional operations in recent years. Joint and multinational operations, peacekeeping missions, and support of FEMA efforts present challenges to the security of U.S. forces and systems that never before existed. During the same period, the U.S. military has adopted a host of new information and communications capabilities. Equipment formally used at the secret or NOFORN levels also is used for unclassified FEMA operations and in multinational operations. In recent years, nation states that were once on opposite sides of conflicts are now part of the NATO coalition forces. Thus, a new requirement has emerged to reuse tactical communications equipment at different classification levels for a variety of missions. IA technologies must be employed to provide a high degree of assurance that sensitive information used in one mission is completely wiped from the equipment before it is used in subsequent missions.

Tactical data wiping is typically performed for one of three primary purposes: equipment storage, national level reuse, or multinational reuse. Residual classified or other sensitive information must be totally erased from any storage media residing in tactical communications or computer equipment. This includes information at several different classifications and handling caveats. The reuse of tactical communications equipment at different classifications

## UNCLASSIFIED

Information Assurance for the Tactical Environment  
IATF Release 3.1—September 2002

applies to most types of equipment. In the past, systems such as the Secure Telephone Unit Third Generation (STU)-III solved this problem by implementing a Crypto-ignition Key (CIK) for each STU-III. The combination of a STU/CIK can be programmed to operate at any classification level. When the phone and the key are separated, they are each considered an Unclassified/Controlled Communications Security (COMSEC) Item (CCI). Similar technologies are used in TACLANE and FASTLANE encryptors, as well as with the Krypton Personal Computer (PC) card in the tactical Secure Telephone Equipment (STE). However, creating these keys can take up to a week. Future use of programmable cryptography, multilevel security solutions (see Section 9.10.), and over-the-air updates for Type 1 cryptography will help alleviate this issue.<sup>1</sup>

For many years, tactical forces used communications equipment in a system-high environment. In other words, if the system handled information up to the secret level, all equipment on the network was treated as secret. Units often purchased multiple systems to operate at different system-high classification levels. In some cases, declassification of equipment for reuse in another situation was possible, but time consuming. Declassifying equipment for use at lower classification levels will continue to take weeks, if not longer. When declassification is done before putting equipment into storage, the tactical user may be able to afford the extra time. However, if the equipment will be reused nationally or internationally, time may be a critical factor. In some cases, the declassification process may be overlooked entirely because of urgent mission requirements. With today's limited budgets, U.S. forces do not have the luxury of purchasing multiple sets of systems for each level of classification. Furthermore, the number of multinational operations in which U.S. tactical forces are involved has increased dramatically and will continue to increase in the coming years. Thus, finding solutions for this issue is vital. If IA solutions are not in place to enable rapid equipment reuse at different classification levels, tactical forces will be forced to purchase additional equipment for each system-high level or accept the risk that sensitive information will be compromised. The interim solutions of purchasing additional sets of equipment and relying on a time-consuming declassification process must be replaced by faster, higher assurance solutions.

As an example of multinational reuse of tactical equipment, recent NATO operations in the Balkans and U.S. operations in Afghanistan have demonstrated the trend toward use of multinational forces in tactical operations. U.S. forces frequently report to coalition commanders from other nations. In addition to the usual issues (language, standard operating procedures) arising from a multinational chain of command, U.S. forces must protect cryptographic keys and algorithms from falling into the wrong hands because a coalition partner today may be an adversary tomorrow. To prevent our IA solutions from being used against U.S. forces in the future, security solutions such as tamper-proof cryptography, programmable cryptographic chips,

---

1 Throughout this chapter (and other chapters and sections), reference is made to Type 1 strength cryptography. In traditional usage, this has meant government-developed or -sponsored equipment containing security mechanisms that meet some minimum strength of implementation. Enough assurance mechanisms were in place to reduce compromising failures to acceptable levels. In the context that the term is used here, Type 1 is generalized to include any source of equipment provided that robust minimums of cryptographic strength and assurance mechanisms have been included in the design. The exact definition of these assurances and strengths is beyond the scope of this document. This definition of Type 1 is also used in Section 5 (Defend the Network and Infrastructure).



and over-the-air key load and zeroize functions should be implemented in future tactical communications equipment.

## 9.2.2 Consolidated Requirements

- IA technologies must be available to completely remove sensitive information from storage media on tactical communications and computer equipment and ensure that the data is not recoverable.
- IA technologies must allow for equipment reuse at different classification levels.
- Equipment declassification processes must be accomplished rapidly (in a matter of minutes).
- Solutions such as tamper-proof cryptography, programmable cryptographic chips, and over-the-air key load and zeroize functions should be implemented in future tactical communications equipment.

## 9.2.3 Technology Assessment

To prevent our IA solutions from being used against U.S. forces in the future, security solutions such as tamper-proof cryptography, programmable cryptographic chips, and over-the-air key load and zeroize functions should continue to be implemented in future tactical communications equipment. A viable multilevel security solution, discussed in Section 9.10, Multilevel Security (MLS), also may help address this issue.

For computer hard drives and other magnetic media, several software packages exist to purge classified data from a storage device. Two primary types of wiping software are available today: software that purges all data from a media, and software that purges deleted data from a media. These packages also can be used by certain tactical units to purge data from PCs and other magnetic media. However, much of the legacy communications equipment used by tactical units does not interface well with PC software or PC-based networks. Tactical radios may store sensitive information about a particular communications network that has to be erased before reusing the equipment in an unclassified scenario. Legacy cryptographic equipment can usually be zeroized with the press of a button, and new keys can be loaded at different classification levels. However, many of these legacy cryptographic systems are still considered sensitive even after they have been zeroized because of their internal design and the algorithms used. Newer programmable cryptographic chips will be able to wipe keys and algorithms from the chip, leaving a totally unclassified chip capable of being reloaded with new keys and algorithms.

With standard workstations, the weaknesses of current operating systems (OS) make the reuse of computers for different classification levels especially vexing. The allocation of data in swap files, the creation of temporary files, the storage of data in slack and unallocated space, and the actual nondeletion of data despite using the delete command all constitute a potentially serious security hazard. Given the easy availability of hacking tools and forensic software, the

possibility of data recovery is especially high. Although commercial off-the-shelf (COTS) memory shredding application software (e.g., BC Wipe, Erase, Kremlin, and Puffer) exists—and there is a DoD standard for file wiping—the most secure solution is the total removal of all previously used storage media prior to reuse of the basic computer. This decision should be based on a careful risk analysis of the individual situation.

**Note:** Users should consult local security policy for a list of approved wiping software before using any of the software applications listed above.

## 9.2.4 Framework Guidance

Given the current state of technology, the best available solution continues to be removable storage media and zeroize functionality. Equipment can easily be reused in different missions by inserting a new storage media at the appropriate classification level. The zeroize function would also allow new cryptographic keys to be loaded at the appropriate classification level for the new mission. The desired solution involves the use of programmable cryptographic chips used in conjunction with a secure OS. The secure OS ensures that all copies of sensitive files are handled at the appropriate classification level. Users without the appropriate authorizations cannot access the protected information. The programmable cryptographic chip would allow simple key and algorithm updates capable of upgrading or downgrading the equipment classification. Development and use of both programmable cryptography and secure OS are in their infancy. As technology matures, new solutions will be available to address this issue.

## 9.3 Stored Data Protection in a Hostile Environment

Tactical forces always have been faced with the possibility of enemy capture or overrun and the seizure of critical, sensitive, or classified information. In modern warfare, an increasing amount of information is stored electronically. Although this has reduced the volume of sensitive documents and cryptographic material that must accompany a tactical unit to the battlefield, the problem of quickly destroying classified information in an overrun situation has merely changed—not been eliminated. Implementing strong, high-speed, and high-volume media encryption technologies would help mitigate the danger of compromised information, even if tactical communications or information system equipment falls into enemy hands. Alternatively, robust means of quickly rendering digital media unreadable are necessary.

The tactical requirement for media encryption differs from a nontactical situation in two primary areas. First, the information stored in tactical equipment is often very perishable or time sensitive. That is, after a period of time, the utility of the information expires and it no longer requires protection. Although this is not true for all tactical data, typically the media encryption needs to be only good enough to prevent the enemy from breaking the encryption within a short period (days to weeks). For example, information concerning an upcoming attack is classified

## UNCLASSIFIED

Information Assurance for the Tactical Environment  
IATF Release 3.1—September 2002

only before the attack takes place. If information stored on a system pertains to an attack happening in three days, the encryption may only need to be strong enough to prevent an adversary from accessing the information for a week or more.

Second, tactical users often require extremely fast (near real time) media encryption. The media encryption process should be transparent to the tactical user, allowing the user to control the process in real-time and quickly protect the information in a time of crisis. If an Army unit is under attack by the enemy, a soldier may require the capability to rapidly encrypt large storage devices in case the enemy captures the equipment.

### 9.3.1 Mission Need

Equipment subject to theft or recovery by an adversary must have the capability to adequately protect the information stored within the equipment. Current media and file encryption techniques are too slow for use in tactical situations. Media encryption of 1 to 2 GByte hard drives must be accomplished within minutes rather than hours. In tactical situations, zeroization is often used to destroy sensitive information if enemy forces will likely recover the equipment. Until strong, fast media encryption technologies are developed, zeroization will continue to be used in these situations. Once the equipment is zeroized, critical data is lost forever, and it cannot be recovered if the equipment is not captured. Thus, soldiers are often hesitant to hit the zeroize key if there is a chance of defeating the attackers. Unfortunately, this sometimes means that capture happens before zeroization.

Alternatively, sensitive information used in a tactical scenario could be maintained entirely in an encrypted state. Warfighters would then pull, (i.e., decrypt) only the information needed at a particular time. The remainder of the disk or other storage device could remain encrypted until required by the warfighter, thereby limiting the amount of information that can be recovered by an adversary. This method involves file encryption, instead of the more extensive media encryption technique that would encrypt the entire storage media. Thus, a method for pulling subsets of information from an encrypted drive while maintaining encryption for the remaining data on the drive is also a tactical requirement. This solution would enable encryption of the storage media that is transparent to the user because of the limited amount of information stored in the clear at any point in time. Unlike zeroization, media encryption allows data recovery, enabling the soldiers to press the media encryption key first, so they can concentrate on defending themselves.

As stated previously, not all tactical information is perishable. Some data stored on tactical equipment may require more extensive protection because the sensitive nature of the data persists beyond today's operation. Examples of these types of data would be information on weapons systems, classified procedures, or other information that would remain classified long after the tactical operation is complete. Clearly, the user must first determine the perishability of the information before deciding on the strength of encryption required to protect the data.

## 9.3.2 Consolidated Requirements

- Tactical communications systems subject to theft or overrun by an adversary must have a real-time method of protecting sensitive information. Tactical information is often time sensitive or perishable. A decision must first be made about the perishability of the information. Then, the tactical user requires confidentiality services that can be rapidly applied to the information according to the sensitivity and perishability.
- A real-time means of protecting digital media must be available for the tactical user enabling the warfighter to quickly protect sensitive information in a time of crisis. Ideally, these services should operate transparent to the user.
- Near-term solutions using file encryption must have a method for pulling subsets of information from an encrypted drive while maintaining confidentiality for the remaining data on the drive.

## 9.3.3 Technology Assessment

Tactical success requires encryption hardware and software that can meet time-critical requirements and provide real-time encryption/decryption. Tactical systems must process encryption requests at speeds essentially equal to those of unencrypted requests. High-performance, real-time bulk encryption requires data rates that stretch the performance parameters of available hardware and software. Media encryptors specifically protect the confidentiality and integrity of data storage media. They are designed to encrypt the entire contents of the storage media (less certain system files in computers).

Generally, tactical equipment that is subject to recovery and exploitation by the enemy is better protected by media encryption versus file encryption techniques. Much tactical information is time sensitive and fast moving. Sorting out information for file type encryption is not feasible; thus protection of the entire storage media is more desirable. This process requires real-time media encryption to protect all the data in a timely manner. The wiring of the battlefield down to the individual soldier, and the enormous variety of communicated data, demands fast bulk media encryption and storage in a highly user-transparent manner.

Prime examples of the applications in the current technology are the developments in the FORTEZZA<sup>®</sup> family. Tactical applications for real-time encryption of mass storage devices including hard disks, floppy disks, tape drive, compact disc-read-only memory (CD ROM) and magneto-optical backup storage are coming on line. Promising COTS developments in dedicated Protocol Control Information (PCI) card encryption accelerators and faster algorithms coupled with tamper-proofing technology need to be integrated in a total protection package to reduce the threat of exploitation of recovered/captured equipment.

## 9.3.4 Framework Guidance

To meet this requirement in the near term, rapid media encryption can be accomplished on a file-by-file basis, rather than a total media encryption basis. However, this method does not provide the desired degree of assurance that the OS has not made duplicate copies of sensitive information in temporary files. This Framework recommends further developments of trusted OSs, as well as faster media encryption technologies that will operate transparent to the user.

## 9.4 Key Management in a Tactical Environment

Overall key management for a tactical communication network involves generation, distribution, and storage of keying materials. Clearly, this process requires an extensive key management infrastructure (KMI) to handle the number of users in a tactical environment. Fortunately, the U.S. military has spent many years improving the current KMI used to distribute symmetric keys to troops around the world. Entire documents have been written on the structure of the military's KMI. This document does not describe the entire key management process; instead, it discusses some of the current issues related to key management in a tactical environment. These issues include black key transfer, remote rekey, transfer, zeroize functions, and key loading functions.

Remote rekey has become a major IA issue in recent years for several reasons. The capability of a user to rekey COMSEC equipment from a remote location eliminates the need to either bring equipment to a central location, or send key updates to field locations. Any dangers of key compromise along the shipping process are eliminated, along with drastically reducing the time required for key updates. More importantly in a tactical situation, if a node in a network should be compromised, a good network management and control system can lock out compromised nodes and remotely rekey all other nodes in a network. Thus, an adversary who obtains keys and communications equipment cannot listen to sensitive communications or attempt spoofing attacks against friendly forces by pretending to be a valid user on the net.

### 9.4.1 Mission Need

One of the primary concerns for the warfighter is the elimination of red key. The current Electronic Key Management System (EKMS) delivers black key from the Central Facility to the Local Management Device/Key Processor (LMD/KP). For the tactical Army, this brings keys down to the division level in a benign, secure manner. However, transfer of keys from division down to brigade, battalion, and below is performed by a soldier carrying a key fill device, such as the Data Transfer Device (DTD), full of red keys. This soldier is a target waiting to be exploited. Thus, the tactical warfighter requires a KMI that can receive black keys all the way down to the end COMSEC unit. That is, there should be no point in the transfer of keys where they are stored red. This will minimize the risk of insider attack and ease compromise recovery.

## UNCLASSIFIED

Information Assurance for the Tactical Environment  
IATF Release 3.1—September 2002

Remote rekey and network management can be accomplished with over-the-air rekey (OTAR) or across a landline, as with a STU-III or STE. Over-the-air zeroize (OTAZ) and over-the-air transfer (OTAT) of keys are closely related to OTAR. These processes involve the rekey, zeroize, and transfer of keys across a communications link from a centralized key management center to deployed COMSEC equipment. One IA challenge with these processes is how to confirm the identity of the network control station and the end-user equipment. Without proper identification and authentication (I&A) services, a sophisticated adversary could conceivably impersonate the network control station, send out a key update, and take control of part of the tactical network. Therefore, the first requirement for OTAR systems is to implement high-assurance key management capability, using remote rekey mechanisms in tactical networks to ensure access control, integrity, and confidentiality for the rekey message.

The second requirement for OTAR systems is an automated process for conducting OTAR that can run on any tactical automation system, such as the Maneuver Control System (MCS). An operator at the key management center would program the software to automatically send out new keys at a designated time. Any system that does not acknowledge receipt is identified quickly by the OTAR system, and the status of that particular unit or individual would then be verified. These types of systems exist for the Data Encryption Standard (DES) and other Type III federal systems but not for Type I tactical systems.

Third, a common key fill device is required to operate with multiple types of cryptographic keys and multiple end systems. If the tactical user requires three or four different key loading mechanisms in the field, units must bring extra COMSEC equipment to the field. With a single-key fill device, this equipment burden could be reduced drastically.

Remote keying mechanisms are essential to eliminating the need to bring large numbers of COMSEC items to the field. For example, implementing OTAR and OTAT mechanisms, a unit would only need the initial key fill for COMSEC equipment deploying to the field. All other updates would be accomplished remotely. If tactical forces operating in hostile territory rely on remote keying, the chance of an enemy gaining access to COMSEC keys would decline significantly. However, remote keying places a high degree of trust in the key management and network management functions. If tactical units rely on an automated system to send out key updates, significant IA must exist within the automated system. Tactical forces must have total confidence in the rekey process. Forward units must know that the enemy cannot spoof the network management station by sending out false COMSEC updates to friendly equipment. If there is any doubt about the validity of keying information, units may choose to operate “in the clear,” without encryption, instead of possibly accepting a rekey from hostile forces.

Additionally, if any tactical COMSEC devices or keys are captured, all other nodes on communication nets using the compromised keys must be notified immediately. Many of these processes are in place today for single-key types in legacy cryptographic systems. However, the process is not as clear for public key infrastructure (PKI) and reprogrammable cryptographic devices handling keys for multiple networks. Improvements in I&A of network control stations will provide a much higher degree of assurance that the enemy has not spoofed a network control station. A final requirement is the development of a KMI to deal with EKMS, PKI, and reprogrammable cryptography. Additionally, to fully realize the potential of programmable

cryptography, current COMSEC algorithms should be integrated into programmable COMSEC chips.

## 9.4.2 Consolidated Requirements

- Tactical users require the development of a KMI to deal with EKMS, PKI, and reprogrammable cryptography. High-assurance remote key management capabilities must be implemented in tactical networks, including methods for conducting OTAR, OTAT, and OTAZ. Additionally, processes must be established to disseminate compromised key information for PKI and reprogrammable cryptographic devices handling keys for multiple networks.
- Tactical users require a process to transfer black key all the way down to the end COMSEC unit on the battlefield, dramatically reducing the vulnerability of key compromise.
- High-assurance I&A services must exist for both network control stations and end users for OTAR, OTAT, and OTAZ.
- Tactical users must have an automated process for conducting OTAR that can run on any tactical automation system.
- Tactical users must have a common key fill device to operate with multiple types of cryptographic keys and multiple end systems.

## 9.4.3 Technology Assessment

This section focuses on technologies associated with key loading, remote rekey, OTAR, OTAZ, and OTAT. A section on PKI has been added to address the movement to public keying in future DoD systems.

OTAR is not a new topic for tactical communications systems. The Army's mainstay radio system, Single Channel Ground and Airborne Radio System (SINCGARS), has a remote rekey capability. Other systems throughout DoD also have this capability. The issues discussed in this section are specific to certain aspects of remote keying, including Type 1 automated tactical OTAR, Type 1 OTAZ, the development of a single-key fill device, and development of a common compromise policy and recovery method for programmable cryptography devices.

OTAR is an effective way to distribute key updates to deployed forces in a tactical scenario. It reduces the amount of keying material that must be transported to the field, which increases the risk of key compromise. Additional improvements to the OTAR process should focus on developing an automated process for conducting OTAR that can run on any tactical automation system (such as the MCS). An operator at the key management center would program the software to automatically send out new keys at a designated time. Any system that does not acknowledge receipt is quickly identified by the OTAR system, and the status of that unit or

individual would then be verified. These types of systems exist for DES and other Type III federal systems, but not for Type I tactical systems.

In contrast to OTAR, very few OTAZ schemes are approved for military radio systems. A common scheme should be developed for use in all future DoD tactical radio systems. Similarly, there is no single-key fill device available to support the variety of COMSEC systems fielded. With different key fill devices available for Type I, Type III, public key, and commercial key systems, a tactical unit often carries a multitude of fill devices to the field. A common fill device would lighten the load for the warfighter, and reduce the requirement to protect and store the additional devices. Some devices currently used for downloading keys to COMSEC devices are the DTD, KYK-13, KYX-15, or KOI-18. The DTD is probably the most interoperable key loading device currently used, compatible with such COMSEC equipment as SINCGARS radios, VINSON, KG-84, and others that are keyed by Common Fill Devices (CFD). The next version of the DTD, the DTD 2000, is under development.

Another requirement that must be met by a tactical key management system is a common compromise and recovery policy. If programmable cryptographic devices are used in tactical radios of the future, each unit may have radios keyed for multiple networks. The specific networks may vary from unit to unit or from one contingency to another. As an example, if a radio is compromised with keys for SINCGARS, HaveQuick, and Enhanced Position/Location Reporting System (EPLRS) nets, a chain of notification, including the designated key compromise authority for each type of key, needs to be identified. A set time for key changes and a new key distribution schedule need to be identified as well.

## Public Key Infrastructure

Success in accomplishing the mission in the tactical environment depends to a large degree on the establishment of a secure means of moving information resources—data, voice, and imagery—to support the effort. Implementing a PKI will certainly not solve all tactical IA problems. However, a robust PKI could become a critical component of a fieldable IA solution for battlefield and other tactical operations.

PKI allows tactical users to interact with other users and applications, to obtain and verify identities and keys, and to provide other authentication services. There are three primary levels of assurance: high, medium, and basic. In the DoD, PKI certificates will be issued for medium and high assurance only. DoD has no plans to support a separate basic level infrastructure. This is not to imply that PKI services at the basic level of assurance will not be of importance to DoD, only that these services will be provided by the medium assurance infrastructure. High assurance is provided by Class 4 certificates such as FORTEZZA<sup>®</sup> cards. High assurance devices are generally hardware-based tokens providing protection for Unclassified but Controlled mission-critical information over unencrypted networks (Type 2 information). Medium assurance refers to software-based end-user tokens (Class 3 certificates) requiring in-person or trusted agent registration that will eventually migrate to a common smart card such as the DoD identification card. Medium assurance certificates can protect less sensitive information such as support and administrative information. Basic assurance refers to lower



## UNCLASSIFIED

Information Assurance for the Tactical Environment  
IATF Release 3.1—September 2002

assurance, software-based solutions providing minimal protection because of the lack of registration controls.

A critical issue for tactical communications is interoperability over a wide range of vendors' products and standards. This is compounded by the likely requirement to interoperate with a large number of PKIs from allied military forces and other elements of the U.S. and allied governments. These other PKIs may be based on different products, certificate policies, and algorithms. Technology in this area is still evolving. Key tactical issues such as compromise recovery, key recovery, and rapid personnel transfers must be addressed. Public key cryptography is one of the most promising emerging technologies, but the Framework required to support a viable PKI, needs to be carefully thought out and established.

### 9.4.4 Framework Guidance

Key management in a tactical environment has been handled by the Services for many years for symmetric key types. However, as the DoD moves closer to adopting a total PKI solution, tactical key management also will require modifications. This Framework strongly recommends that any new system under development be able to receive black key all the way down to the end COMSEC unit. In other words, there should be no point in the transfer of key where it is stored red. This will minimize the risk of insider attack, decrease the risk to the warfighter carrying red key, and ease compromise recovery. Current systems that provide an OTAR capability (e.g., SINGARS) should continue to take advantage of their remote rekey functionality. As interoperability between networks increases, the Services must work to develop a common compromise and key recovery policy for use with tactical systems loaded with multiple COMSEC keys for different networks. This technology gap will be particularly important as tactical communications equipment begins to implement programmable Information Systems Security (INFOSEC) devices. Furthermore, a single key fill device for all tactical COMSEC equipment does not exist. Industry should focus on this area in the near future. Finally, this Framework encourages the continued development of programmable cryptographic devices, and the implementation of current COMSEC algorithms on these devices. Future systems such as JTRS will play a key part in not only the use of programmable cryptographic devices, but also the refinement of current key management policies and procedures in the tactical arena.

## 9.5 Network Mobility/Dynamic Networks

U.S. tactical forces conduct a majority of their operations in locations outside the CONUS. Therefore, a need exists for these forces to maintain seamless network connectivity regardless of location. In the civilian world, a business traveler can remotely access his or her company's network from anywhere in the world through a dialup remote access connection or by simply acquiring an Internet connection at the mobile location and accessing files and e-mail through a network connection. In either case, tracing phone numbers or IP addresses can trace the traveling businessman to a specific location. Such location tracking is not desirable for a tactical user because specific locations of tactical units are often sensitive, if not classified.

## 9.5.1 Mission Need

Consider the case of establishing a deployed LAN with an Internet server. A new host IP address must be assigned at each location, forcing frequent updates of the Domain Name Server (DNS). One requirement for mobile tactical users is the capability to seamlessly connect to a local subnetwork anywhere in the deployed tactical network. Tactical operations often combine equipment from different units, forming several different subnets. Users need continuous access to the network as they move between subnets, regardless of which unit “owns” the subnet. The tactical user does not have time to reconfigure local IP address information every time the subnet changes. Furthermore, IA technologies must exist to protect the packets against active and passive attacks by unauthorized individuals from both the home and foreign subnets visited by the tactical user. Although making it easier for authorized users to travel between subnets, the deployed tactical network must still employ IA mechanisms that authenticate mobile users to prevent the adversary from gaining access somewhere in the network.

A different, but related, mobility requirement for tactical forces is the need for rapid setup and teardown of communications networks. Tactical network applications differ from fixed plant applications in that tactical networks are mobile. Tactical units rarely stay in the same location for the duration of an operation. Therefore, networks that require vast amounts of cabling are often impractical for use in a tactical operation. To the extent possible, bulky cabling should be replaced by wireless solutions in future highly mobile systems. Of course, wireless systems present additional challenges such as jamming and geolocating that also must be addressed. The point is that security services should not increase equipment setup time for the warfighter. Secure wireless network solutions for tactical applications are a key area for industry development. IATF Section 5.2, Wireless Communications, discusses wireless systems.

Tactical mobility can also be achieved by using global broadcast communications systems and UAVs used as communications nodes. Although these topics apply to tactical network mobility, they are covered more specifically in Section 9.7, Secure Net Broadcast/Multicast.

A Tactical Operations Center (TOC) is today’s central communications hub for most Army tactical information systems. Setting up a TOC and running all the required cabling can take from 24 to 48 hours. This is too long. Therefore, rapid setup and teardown can become a major issue. An airborne unit may have more of a challenge with TOC mobility than a less mobile Army unit because an airborne unit is considered a “shoot and move” unit, requiring a more mobile TOC. In this situation, full communications capability can lag behind the unit because of the time required to setup a TOC. Replacing cabling with wireless connections would drastically decrease set up time. Additionally, wireless solutions allow the creation of a *mobile* TOC, installed in a set of three or four vehicles, with communications staying “up and running” while the TOC is on the move. The U.S. Army’s First Digitized Division is attempting to implement a mobile TOC in several vehicles with wireless bridges and TACLANE encryptors. The TACLANE encryptor is discussed later in this section.

Regarding mobile networking, the security implications depend on the type of tactical application in question. Without dynamic networking solutions in place, seamless message

## UNCLASSIFIED

Information Assurance for the Tactical Environment  
IATF Release 3.1—September 2002

addressing is more difficult. Individuals sending messages to tactical forces must know the network address of the recipient before sending a message. Also, an adversary may more easily locate U.S. forces at deployed locations by watching message headers flowing across a network. However, not all tactical units are particularly concerned about the enemy knowing their location. Thus, this issue will vary in importance depending on the particular tactical information system application.

Mobile wireless networks have an increased possibility of eavesdropping, spoofing, and denial of service attacks. The mobile networking concepts under development must account for information security hazards such as these in their development phase. For example, in an IP network, routers continuously broadcast routing tables to other nodes in the network to help other routers choose the best route to send IP packets. However, if this broadcast is done in the clear on a wireless net, an adversary could quickly glean an approximate picture of the layout of the tactical network. A second challenge in applying these technologies in the tactical arena involves incorporating routing and security functionality in smaller form factors such as handheld radios. Size, weight, and power requirements for computer equipment will continue to decrease as technology improves, which may help alleviate this issue. Future tactical equipment will require secure protection for over-the-air exposure of user information, addressing, system control information, and portable processing. Where routing functionality is provided in addition to the traditional radio applications, routing tables must be transmitted on a secure channel that all nodes in the network can access.

Finally, new mobile ad hoc networking technologies must remain backward compatible with certain legacy communications equipment. Even as new technologies become available, tactical units will retain much of their legacy communications equipment because of large upgrade costs and experience with current systems. Thus, legacy radio addressing will remain a key issue to consider when developing new mobile networking technologies.

### 9.5.2 Consolidated Requirements

- Tactical users must have the capability to maintain seamless network connectivity regardless of location or subnet. Network routing and domain name servers must have the ability to forward data to tactical users moving between networks. Users require continuous access to the subnets as they move through the field.
- IA protections for tactical networks must be flexible enough to operate on different types of equipment from various units worldwide.
- IA solutions must prevent access to any subnet by unauthorized users.
- Many tactical users require protection against geolocation by an adversary. Therefore, dynamic networking solutions must provide confidentiality for specific location information where necessary.

- Tactical communications equipment must be capable of rapid setup and teardown, allowing greater mobility for the tactical unit. Security solutions should be applied in smaller form factors (e.g., handheld and man-portable).
- Mobile networking concepts developed for the tactical environment must address passive and active attacks from a sophisticated adversary.
- Tactical wireless solutions should implement Low Probability of Intercept (LPI), Low Probability of Detection (LPD), and Antijam (AJ) technologies to provide transmission security (TRANSEC) as required for the particular tactical mission.
- Advanced networking technologies must remain backward compatible with major legacy communications systems and equipment.

### 9.5.3 Technology Assessment

Significant advances in mobile IP technologies have made several of these tactical mobility requirements a reality. As discussed in IATF Section 4.4, Important Security Technologies, Internet Protocol Security (IPSec) used in mobile IP enables a mobile node to change its attachment point on the Internet while maintaining its IP address(es) and protecting its communications when visiting foreign subnets. Traveling between subnets resembles a cellular user roaming from one cell to another. However, future advances in mobile wireless communications will likely involve the use of the IP suite. Using IP in a cellular-like roaming situation creates several IA issues that must be solved.

The message originator wants assurance that a message will reach the correct destination, regardless of the physical location of the recipient, without any chance of interception or spoofing by an adversary. This also must be true, even when the originator does not know the location of the recipient. Likewise, a recipient must ensure that received messages from the “commander” are indeed from the commander, regardless of where in the network the commander is located. In an attempt to solve these assured delivery and nonrepudiation problems, a concept of mobile ad hoc networking (MANET) has been developed to support robust and efficient operation in mobile wireless networks by incorporating routing functionality into mobile nodes. Such networks are envisioned to have dynamic, random, multihop technologies that are likely composed of relatively bandwidth-constrained wireless links. This vision differs from Mobile IP technologies in that the goal of mobile ad hoc networking is to extend mobility into the realm of autonomous, mobile, and wireless domains, where a set of nodes, which may be combined routers and hosts, form the network routing infrastructure in an ad hoc manner.

#### Mobile IP and MANET

MANET is an autonomous system of mobile routers and associated hosts connected by wireless links. The routers are free to move randomly and organize themselves arbitrarily, thus allowing the network’s wireless topology to change rapidly and unpredictably. Such a network may operate in a stand-alone manner or may be connected to the larger Internet. [1] These nodes

## UNCLASSIFIED

Information Assurance for the Tactical Environment  
IATF Release 3.1—September 2002

principally consist of a router, which may be physically attached to multiple IP hosts or IP addressable devices. This router may have potentially multiple wireless interfaces, each using various wireless technologies. [1]

Mobile nodes are mobile platforms that make up a MANET. These nodes may be located on airplanes, ships, trucks, and cars. The MANET system may operate in isolation or may have gateways to interface with a fixed network. The MANET system consists of dynamic topology. With this topology, nodes are free to move arbitrarily; thus, the network topology, which is typically multihop, may change randomly and rapidly at unpredictable times and may consist of bidirectional and unidirectional links. The decentralized nature of network control in MANETs provides additional robustness against the single points of failure of more centralized approaches. [2] MANETs also have limited physical security. Mobile wireless networks generally are more vulnerable to physical security threats than cable networks. There is an increased possibility of eavesdropping, spoofing, and denial of service attacks with wireless networks.

This protocol permits mobile internetworking to be performed on the network layer; however, it also introduces new vulnerabilities to the global Internet. First, the possibility exists for an adversary to spoof the identity of a mobile node and redirect the packets destined for the mobile node to other network locations. Second, potentially hostile nodes could launch passive/active attacks against one another when they use common network resources and services offered by a mobility supporting subnet. The first vulnerability can be surmounted by the strong authentication mechanisms built into both basic Mobile IP and route optimized Mobile IP. [2] By using PKI, a scalable countermeasure against the spoofing attack can readily be deployed. An effort is under way to surmount the second vulnerability.

Mobile IP and mobile nodes have several requirements to allow for maximization of security. First, when a mobile node is on its home network and a Correspondent Host (CH) sends packets to the mobile node, the mobile node must obtain these packets and answer them as a normal host. However, if the mobile node is away from its home network, it needs an agent to work on its behalf. [3] The second requirement is that of the expectation of the mobile nodes to retain their network services and protect their communications when they visit foreign subnets and the expectation of the foreign subnets to protect their network resources and local traffic while they are visited by the mobile nodes. A mobile node roaming over the Internet should have safe and persistent IP connectivity that is permitted by the policies of its home and visiting subnets. Persistency of IP connectivity means that the connections should be handed off quickly and correctly so that the mobile node can maintain its Transmission Control Protocol (TCP) sessions when it changes its network attachment point. [4]

Additional information about Mobile IP is available at Web site:

[http://www.hpl.hp.com/personal/Jean\\_Tourrilhes/MobileIP/](http://www.hpl.hp.com/personal/Jean_Tourrilhes/MobileIP/). [3] For additional information about MANET, visit Web site <http://www.ietf.org/html.charters/manet-charter.html>. [1]

## TACLANE/FASTLANE/TACLANE Internet Security Manager

In an effort to overcome some of the drawbacks and interoperability issues with current bulk encryption technologies, two Type 1 IP and Asynchronous Transfer Mode (ATM) encryptors have been developed for the National Security Agency: TACLANE (KG-175) and FASTLANE (KG-75). These encryptors provide access control, authentication, confidentiality, and data integrity for individuals or groups of users. TACLANE encryptors are more likely to be used in a tactical scenario because of size and mobility issues. The Army's First Digitized Division uses TACLANE encryptors with a wireless bridge to set up a wireless tactical operations center among a suite of vehicles.

The TACLANE encryptor will secure communications in a dynamic TPN, in the Defense Information Systems Network, or over the Internet, facilitating integration of these and other mobile and fixed networks. This encryptor operates at 45 Mbps for ATM networks and 4 Mbps for IP networks. A new, smaller version of the encryptor, "TACLANE Lite," is a PC card size device that is compatible with TACLANE. The PC card version supports data rates from 1 to 45 Mbps. The reduced size, weight, and power will allow greater operational interoperability.

These encryptors support different levels of secure transmission by employing crypto-ignition keys, much like a STU-III or a FORTEZZA card in the STE. When the CIK is removed, the encryptors are Unclassified/CCI. As mentioned in Section 9.2, Wiping Classified Data From Tactical Equipment, changing the assigned classification level of a CIK is possible, but it requires a significant amount of time (potentially several days). Ideally, future systems will be able to operate at multiple security levels without undergoing a lengthy rekey process. The real strength of these encryptors comes from the integration of the TACLANE Internet Security Manager (TISM) in the tactical network. The TISM allows remote management of encryptors and their protected devices from a central location.

The TISM provides remote rekey of the FIREFLY keying material in the TACLANE and FASTLANE encryptors, reducing the chance of compromise by eliminating manual distribution of keys. Also, FIREFLY and traditional keys can be assigned to FASTLANE and TACLANE ATM virtual circuits with the ability to activate and deactivate them. Furthermore, audit data from encryptors throughout the network can be collected and reviewed in a central location, looking for errors or evidence of electronic attack on the network. A TISM operator can specify alternate TISM managers as a backup. If a TISM site is compromised or overrun, network management can be conducted from an alternate location. Future enhancements to the TISM include remote zeroization capability and electronic distribution of access control lists.

### 9.5.4 Framework Guidance

Until secure, wireless network solutions are implemented, tactical units will continue to use copper and fiber connections to connect local network nodes. Minimal security challenges arise using copper and fiber instead of wireless. The major drawbacks are longer equipment setup and teardown times and larger lift requirements as a result of the weight of the cabling. On the other hand, there can be a greater risk of jamming and geolocation when using wireless solutions.

## UNCLASSIFIED

Information Assurance for the Tactical Environment  
IATF Release 3.1—September 2002

Thus, tactical wireless solutions should implement LPI, LPD, and AJ TRANSEC as required for the particular tactical mission. System integrators for tactical organizations should also note continuing developments in the mobile networking arena. Many lessons can be learned from the Army's First Digital Division because they implement mobile wireless networking technologies and TACLANE encryption devices. Dynamic addressing schemes will also play a key role in improved communications for mobile users.

In addition, Personal Communications Systems (PCS) on the battlefield are currently in the form of small lightweight cells. This allows the tactical user limited mobility in the Division and rear areas. PCS radio access points and cell sites need to be small and rugged enough to be mounted on vehicles that travel with the tactical users. These cells would have to operate with little or no operator involvement, and the mobile networks would have to be self-configuring as the mobile cells move with respect to their users.

## 9.6 Access to Individual Classified Accounts by Multiple Users

Information systems often make use of shared directories or databases that can be accessed by a group of users for a specific purpose. Users expect to have individual e-mail accounts for sending and receiving messages, files, and other critical information. However, military and other tactical units tend to operate more as a group focused on a particular mission. When communicating with a unit, messages are sent to a particular position, or function within that unit (e.g., Commander or First Sergeant) as opposed to being sent to some specific individual by name (role-based access control versus individual access control). Unfortunately, this means a higher risk of messages or data ending up in inappropriate hands. This is a key concern if an insider threat exists within a unit. With recent advances in access control technologies, significant limitations can be placed on who (by name or by role) may access a particular account, file, or database. Thus, the danger of message traffic ending up in inappropriate hands is eliminated. These access control technologies work well in the commercial world, but it is unclear how well they transfer to tactical operational environments.

Communications systems of the past typically used role-based access control mechanisms, partially because of a lack of sophisticated individual access control technologies, and because of the need for accessibility by several operators on different shifts. Today, the standard password controls can be used in concert with other technologies such as biometrics (fingerprint, retinal, or iris scanners), PKI mechanisms (hardware and software), or other cryptographic tokens. Some of these methods present unique IA issues regarding access to information by a limited number of individuals. These potential solutions are discussed in more detail later in this section. The network must have the ability to uniquely recognize each individual in a tactical scenario and allow that individual access to information in accordance with his or her role-based need to know.

## 9.6.1 Mission Need

In a tactical scenario in which a commander or other key individual could be replaced, captured, or killed, the chain of command is defined so the next person in the chain will assume command seamlessly. If Commander A is removed from the picture, Deputy Commander B must be able to assume command and have access to all messages and files that Commander A had. If the Commander is the only person with the “key” and is captured, the Deputy Commander cannot effectively make command decisions because of a lack of information. Similar single points of failure may exist with system administrators or other critical positions.

As illustrated in the above scenario, new users/commanders must be able to access the same message and database capabilities as former users/commanders. Without the proper multiuser access control technologies in place, one of two outcomes will result. Either the unit will choose not to use the access control mechanisms for the communications equipment, or the unit will risk not having access to critical information if key authorized individuals are unavailable. Therefore, tactical information systems require a fieldable network access control mechanism with an ability to uniquely recognize each individual in a tactical scenario and allow that individual access to information and system use capabilities in accordance with that required and authorized for their role.

In the past, tactical units have typically chosen to use either widely disseminated passwords that are rarely changed, or no access control mechanisms at all. Physical security controls governed which individuals had access to specific information or message services. Unfortunately, enemy capture of equipment has occurred, and enemy forces often became adept at using captured equipment to impersonate U.S. forces on U.S. radio channels. As a result, complicated and burdensome authentication schemes were devised to defeat these impersonation attempts. It is unknown how successful these authentication schemes were. Current tactical communications systems increasingly relay data without operator intervention and must rely on more sophisticated access control systems that provide a high degree of assurance regarding authentication of distant ends. Tactical users must make split-second decisions that could have grave consequences. If the user suspects that distant end access control has been breached, messages received over the network will not be trusted. Furthermore, any new access control mechanism to be fielded in a tactical environment should be simple and reliable enough to assure the user that information is secure. As with any new technology, new tactical communications networks must earn the user’s trust before reaching their full potential.

## 9.6.2 Consolidated Requirements

- Access control services on tactical equipment must be flexible enough to uniquely recognize each individual and allow that individual access to information based on clearance level and current mission needs.
- Any access control mechanism must be simple and reliable enough to operate in a tactical environment and to assure the user that authentication information is secure.



## 9.6.3 Technology Assessment

IA solutions for this issue continue to develop rapidly. As stated in Section 9.6.1, Mission Needs, any solution must be able to uniquely identify users and grant them access to information in accordance with their individual clearance level. Possible solutions include implementing smart card technology on DoD identification cards, maintaining and using biometric information on all individuals involved in tactical situations, or assigning public key certificates to all DoD personnel reflecting authorized security levels. PKI solutions are described in Section 9.4.3, Technology Assessment. Other technologies are described below.

### DoD-Wide Certificates

DoD plans to issue public key certificates to all military personnel for identification and encryption purposes. By direction of the Deputy Secretary of Defense, all DoD users will be issued, as a minimum, Class 3 (medium assurance) certificates by October 2001. Beginning in January 2002, the Class 3 certificates will be replaced by Class 4, high assurance certificates for all DoD users. [5] DoD PKI medium assurance certificates located on smart cards or floppy disks are starting to be used by DoD personnel interfacing with the Defense Finance and Accounting Service (DFAS). These certificates could transfer well to a tactical network application to validate the identity of system users and the authenticity of messages received from those users. The primary reason certificates exist is to associate individuals with their public key. [6]

### Biometrics

Biometrics is the statistical analysis of biological observations and phenomena. Biometrics identity verification systems use biometrics as a method for recognizing a person by measuring one or more specific physiological or behavioral characteristics, with the goal of distinguishing that person from all others. Biometric devices must be based on a characteristic that differs in a measurable way for each user. Characteristics that meet this criterion are iris scans, hand geometry, deoxyribonucleic acid (DNA), and fingerprints.

The application of biometric technology in fast moving tactical situations offers some clear advantages. Tokens, smart cards, and physical keys can be lost, stolen, or duplicated, and passwords can be easily forgotten or observed. Only biometrics bases I&A on an intrinsic part of a human being—something that is always available and totally unique.

Applications are coming into use in the commercial and the civilian sectors of the federal and state government. Current military applications, to date, are sparse and appear to center more on use in fixed facilities as opposed to purely tactical applications. However, as the technology progresses, several tactical applications are likely to arise for biometrics. Much of this is anticipated because biometric devices are expected to become widespread in the commercial and government sectors in the next few years. Although biometric applications have been available for many years, recent reductions in the cost of biometrics devices and the introduction of new applications (i.e., controlling network login, Web server access, and media encryptor access) are

driving the deployment of biometric devices. Current shortfalls in the technology related to a tactical environment are as follows:

- **Lack of Standardization.** The government and commercial industry are working together to define a standard for biometric products. The Biometrics Application Program Interface (BAPI) will allow products from multiple vendors to interoperate, preventing one-vendor solutions. Products adhering to the BAPI standard are expected in the near future.
- **Environmental Conditions.** Environmental conditions in a tactical environment may reduce the effectiveness of some biometrics devices. For example, heavy rain may affect facial scanners, dirt or injuries may affect fingerprint scanners, or loud noises may affect vocal recognition devices. These conditions may affect the accuracy of the biometric devices. The use of biometric devices by tactical users wearing protective garments such as gas masks must also be addressed.
- **Computing Power.** Advances in computing power and in biometrics recognition techniques have reduced the computing power required by biometric devices making biometrics more attractive and affordable for strategic environments. However, the low power, low-computing power tactical user may not be able to perform biometric verifications in a timely manner.

Despite these current limitations, biometrics offer some interesting future possibilities for tactical applications. As biometric devices become transportable, the possible applications for a tactical environment become feasible. For example, military units frequently shared equipment, databases, and directories. Access to individual files and databases must be restricted to authorized users only. Biometrics could provide the unique discriminator necessary to restrict access to the authorized user. Users could carry their biometric signature on a smart card. When they require access to a system, they would insert their smart card, scan their biometric trait, and gain access to the system. Each user carrying his or her biometric on a smart card could provide a strong authentication mechanism that is transportable across multiple units.

## 9.6.4 Framework Guidance

Until DoD realizes the full implementation of DoD PKI, tactical units should continue to use the role-based access control mechanisms in use today. In situations in which one password is shared among multiple users, system administrators should assign unique usernames and passwords to each individual to decrease the chance of password compromise, even though each individual has identical access privileges. Advances in biometric authentication products may or may not prove useful in the tactical arena. ISSEs and system integrators should pay close attention to new developments in this area to determine what applicability they might have to tactical communications systems.

## 9.7 Secure Net Broadcast and Multicast

DoD, military, and civil agencies conduct numerous operations that involve the use of tactical broadcast equipment. These operations can range from U.S. military troops actively involved in war to law enforcement officials conducting a drug raid or seizure. The term “secure net broadcast” refers to a networked communications system where all transmissions from any node in the network can be received by every other node. For voice communications, this network resembles the Citizens Band (CB) radios used in the trucking industry. However, in a tactical environment, broadcast transmissions must maintain confidentiality and integrity during transmission to prevent interception by an adversary. Similarly, multicast transmissions are directed at a subset of nodes in a network. From the early entry phases and throughout the lifetime of tactical missions, voice and data information must be broadcast and multicast to multiple nodes securely and accurately. The tactical equipment used in these exercises must allow users to move rapidly with flexible and survivable voice and data communications.

### 9.7.1 Mission Need

Traditional land mobile radio (LMR) systems may not have the range to handle broadcast communications over a large area; other broadcast and multicast solutions may be required. Several technologies, such as CONDOR, UAVs, Global Broadcast Service (GBS), and PCS, exist to help reduce these vulnerabilities. These technologies provide point-to-multipoint security solutions for wireless communication systems. They also secure data broadcast and multicast by providing a high-bandwidth communications networking infrastructure. In addition, several of these technologies use direct broadcast satellite technology to prevent data interception or jamming.

As mentioned previously, voice and data broadcast and multicast in a tactical environment are subject to many vulnerabilities. Whether it is a military troop in a hostile environment engaged in war or a civil agency performing a drug seizure, operational data must be kept secure and accurate while in transmission from one point to another. During data broadcast and multicast, the data could be intercepted, altered, or jammed if not adequately protected. Any of these vulnerabilities could result in fatalities. For example, in a tactical environment, troops and law enforcement officials attempt to remain undetected while executing the mission or exercise to prevent geolocation, insertion of false messages, or communications jamming, thus giving an adversary the advantage. Any of these threats could lead to disaster for any mission or exercise.

### 9.7.2 Consolidated Requirements

Tactical communications equipment must allow operators to roam over a wide area and still be able to receive and send secure broadcast and multicast data over the local infrastructure. Secure network broadcast and multicast systems include the following security services requirements:

- Tactical users on the move must be able to send and receive voice and data information in a secure and undetectable manner. The minimum acceptable data rate for voice broadcast is 2.4 kilobits per second (kbps).
- During the broadcast and multicast of voice and data information, this information must be protected from detection and identification, transmission jamming, geolocating, RF signal attacks, infrared (IR) signal attacks, and message insertion and modification.
- Tactical communication equipment must be capable of performing rapid, secure broadcast and multicast of high-volume military information such as maps, intelligence data, weather reports, and air tasking orders.
- Tactical communications equipment must have improved filtering to combat interference and jamming that will require advances in Digital Signal Processing (DSP).

### 9.7.3 Technology Assessment

Various security technologies have been developed to improve secure voice and data broadcast and multicast. These security technologies help to reduce the vulnerabilities identified in Section 9.7, Secure Network Broadcast and Multicast.

#### CONDOR

The CONDOR Program provides security in wireless telecommunications systems to meet the communication security requirements of DoD, military, and civil agencies. CONDOR provides point-to-multipoint security solutions for secure network broadcast and multicast service using the FNBDT signaling plan to connect various communications systems, including IS-95 (Code Division Multiple Access [CDMA]), Advanced Mobile Phone Service (AMPS) CypherTac 2000 and the mobile satellite systems of Iridium, Globalstar, and ICO. This signaling plan is also interoperable with the tactical and office STEs. CONDOR phones could prove useful as a broadcast voice solution for tactical commanders on the battlefield. Commanders could have a mobile conferencing capability from any location within the tactical cellular network. For additional information about CONDOR and its technologies, visit the following site: <http://condor.securephone.net>. [7]

#### Unmanned Aerial Vehicle

UAVs used as cell stations will help provide secure network broadcast and multicast communications for the tactical user. UAVs can provide a high-bandwidth, robust, and multimedia theater-level communications networking infrastructure that will protect net data broadcast/multicast from the vulnerabilities of jamming and interception. Currently, UAVs are used primarily as photoreconnaissance platforms. However, to fully use the UAV on the battlefield, the UAV should be used as a cell station, or Airborne Communications Node (ACN). A tactical cellular network could be rapidly established by simply launching the UAV. From an altitude of 20,000 or 30,000 feet, an ACN produces a much larger cell area than a standard cellular tower. The UAV used as an ACN in the tactical Internet can provide warfighters with secure multimedia high-bandwidth Internet-type communications support in hostile tactical

environments where communications must be broadcast and or multicast to various destinations securely and accurately. For additional information on how UAVs can provide secure net data broadcast and multicast, visit <http://www.darpa.mil>. [8]

## Global Broadcast Systems

GBS, developed by DoD, will increase the amount of national and theater-level information broadcast and multicast to deployed forces involved with operations in tactical environments. As the amount of broadcast and multicast data increases, GBS also provides increased security by using direct broadcast satellite technology. GBS enables commanders at the main operating base to transfer vast quantities of information to forward units. This technology protects the data from vulnerabilities such as interception, jamming, and modification.

## Personal Communications Systems

PCS technology products have been developed to send and receive encrypted information from a portable PCS device to a tactical user of the Mobile Subscriber System. Tactical PCS secures network data broadcast and multicast by having radio access points or cell sites made small and rugged enough to mount on vehicles that travel with the tactical users. For tactical missions that require data to be broadcast and multicast to users covering a large area, a UAV may be used to interconnect cell sites throughout the large area to keep the broadcast and multicast data secure. Figure 9-3 illustrates interconnecting cell sites using a UAV.

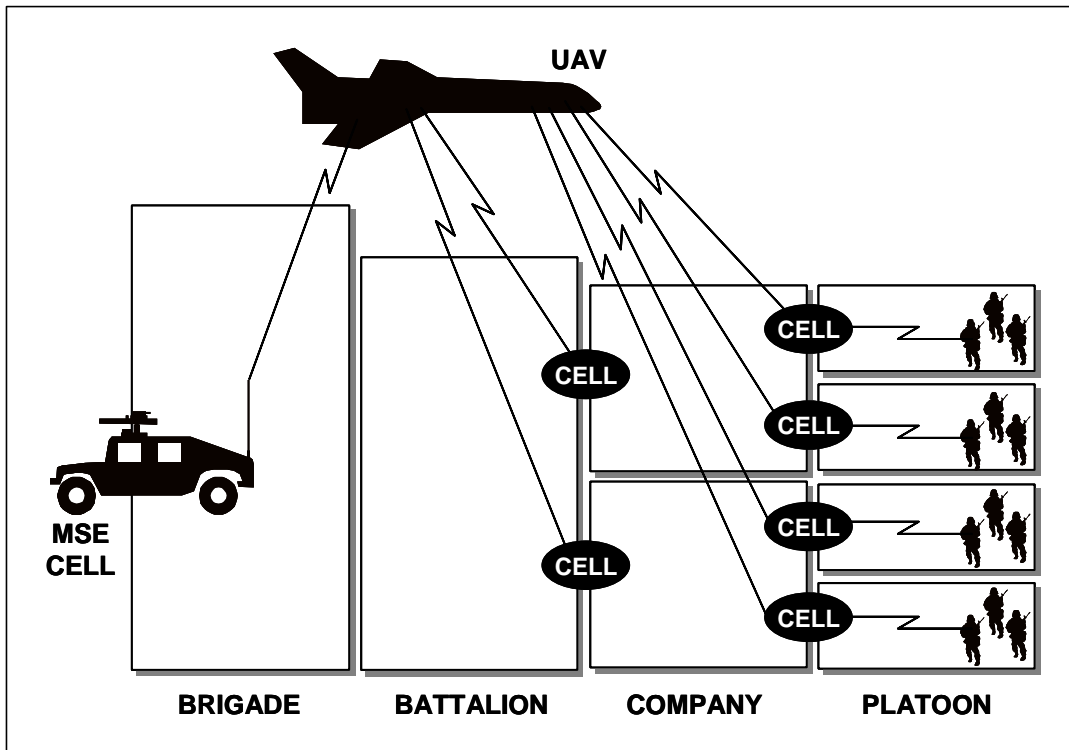

iatf\_9\_3\_0131

Figure 9-3. Interconnecting Cell Sites Using a UAV

## 9.7.4 Framework Guidance

Future tactical systems will demand the use of commercial equipment and infrastructure. Thus, interoperable signaling plans and protocols should be integrated throughout all tactical systems. The FNBDT is a network-independent, common cryptographic and signaling protocol that is implemented in CONDOR and the tactical STE. Inclusion of these protocols in systems such as the JTRS would dramatically improve interoperability, reducing the suite of duplicate systems a tactical user must carry.

Another technology gap involves the use of UAVs as an airborne communications node for tactical cellular. Current military UAVs, particularly the Global Hawk, Dark Star, and Predator systems, are used exclusively for aerial reconnaissance. Significant improvements in tactical C<sup>2</sup> would be possible by expanding the UAV mission to include its use as an ACN.

## 9.8 IA Solutions in Low Bandwidth Communications

One certainty of future tactical communications environments is that the warfighters on the battlefield at the lower levels of the command structure will continue to have smaller bandwidths and lower data rates available to them than the higher echelons. Also, the soldier on the ground or the pilot in the air has significantly less carrying capacity available for additional equipment than do fixed facility organizations. These constraints of bandwidth and lift are key drivers when implementing viable IA solutions at the tactical level.

The combination of limited funding for GOTS IA solutions and improvements in the strength of commercial solutions will lead to military systems of the future relying more on commercial IA tools to provide adequate security services. Unfortunately, IA technologies such as network monitoring systems occupy additional bandwidth that cannot be used for actual communications. To meet the objective of integrating IA solutions into the battlefield, these tools must operate with low bandwidth communications systems at the warfighter level without a noticeable degradation in the speed or accuracy of critical-mission data traffic.

### 9.8.1 Mission Need

DoD would like to implement commercial IA tools in its tactical communications systems to decrease costs while increasing security and interoperability with the sustaining base. However, current tactical systems are not equipped to handle these commercial tools. As reported recently in *Federal Computer Week*: “Tactical battlefield networks under development by the Army and Marines to support operations on future digitized battlefields have vulnerabilities,” according to ‘MG Robert Nabors, commander of the Army’s Communications-Electronics Command. “Army tactical battlefield networks,” Nabors said, “do not have the bandwidth to handle commercial [IA] tools.” [10] Furthermore, current planners estimate that the bandwidth available to the

tactical soldier will likely remain low (tens of kbps). Given these constrained bandwidths, tactical users cannot afford IA solutions that impose additional bandwidth demands. Therefore, there is a requirement to adapt current IA technologies to lower bandwidth applications.

IA solutions that require significant bandwidth are not likely to be employed in the bandwidth-constrained environment of tactical operations, leaving tactical units with no alternative but to continue to operate with low—or no—assurance solutions. Network monitoring systems and intrusion detection systems employed on a tactical communications network can be monitored from the main operating base, or other rear echelon location. However, these systems send monitoring data from the end-user equipment back to the monitoring station. Thus, valuable bandwidth is occupied by monitoring traffic, decreasing the amount of bandwidth available to the warfighter or other operator for vital mission data. Without these IA solutions, a unit's network traffic could be subject to undetected interception and decryption by adversaries, ultimately leading to mission failure and loss of lives.

## 9.8.2 Consolidated Requirements

- Tactical networks require implementation of low profile IA monitoring tools that use minimal network bandwidth.
- In the long term, tactical networks must increase available bandwidth from tens of kbps to tens of Mbps to handle sophisticated, commercial IA tools.

## 9.8.3 Technology Assessment

Legacy military communications and information systems have traditionally been “closed” systems, meaning that equipment is designed specifically for use in one system. This is in contrast to the current philosophy of migrating to an open systems architecture. In the past, low bandwidth communications used symmetric keying systems to provide confidentiality, and few network monitoring applications were available to ensure network security. Systems were not interoperable, and tactical forces learned to work around the constraints associated with closed systems. As communications and information systems move to an open systems environment, radios and networks from the fixed plant to the tactical domains must include a full suite of IA solutions to remain effective for military operations.

Remote network management plays a large part in maintaining the security of tactical networks. Using advanced network monitoring applications, a technical controller can remotely monitor the security of several deployed networks from a central location. Tactical equipment typically has less bandwidth and processor capacity than fixed plant equipment. Therefore, it is more difficult to implement commercial IA tools in tactical communications networks and equipment. Current battlefield networks do not have the bandwidth to handle commercial tools like network monitoring and intrusion detection tools. However, programs are under way that may make it easier to integrate commercial IA tools into tactical systems. Two major programs will benefit from this integration: the JTRS and the Marine Corps End-User Terminal (EUT).

**Note:** The Joint Tactical Radio program applies to several issues in this Framework. To avoid duplication of text throughout each issue, JTRS will be discussed exclusively in this section.

Joint Tactical Radio System (JTRS) will be the next-generation radio for U.S. military forces in the 21st Century. In a memorandum to the Service Acquisition Executives in August 1998, the Office of the Assistant Secretary of Defense for Command, Control, Communications and Intelligence (OASD C<sup>3</sup>I) suspended all other “efforts to initiate any contracting activity to develop and acquire any radio system to include software-programmable radio technology.” The JTRS Joint Program Office (JPO) is responsible for developing a family of JTRS products having common architecture and designed to serve different operational environments. As of this writing, the JTRS JPO was in the Phase 1 process of selecting the architecture to use for the production of the first JTRS prototypes (Phase 2). Therefore, specifics on JTRS will not be available until later revisions of this Framework.

JTRS will be a family of radios that provide simultaneous multiband, multimode, and multiple communications using existing and advanced data waveform capabilities to ensure the timely dissemination of battle space C4I and global navigation information. The JTRS software-defined radio design represents a significant paradigm shift merging the commercial computer and networking industries with the wireless communications industry. Although these technologies may prove beneficial in the commercial industry, implementing IA technologies into a Software Defined Radio (SDR) presents several new challenges. High-assurance software components must be developed and certified to perform in a manner acceptable for Type 1 security. A major benefit of JTRS is the scalability of the architecture. For a tactical unit, a handheld form factor should prove useful in satisfying the need for a low-bandwidth secure solution.

Overall, the benefits of JTRS significantly outweigh any technology issues that arise. Because the JTRS architecture is flexible and relies on many COTS products, a single Joint Tactical Radio can be scaled to meet the needs of any tactical unit. Airborne, vehicular, man-portable, and handheld versions will be available for use in the tactical arena, providing secure and nonsecure voice, video, and data communications using multiple narrowband and wideband waveforms. Operators will be able to load and/or reconfigure modes and capabilities of the radio while in the operational environment. Techniques such as OTAR, OTAZ, and other key management services are employed to overcome several of the IA issues discussed in this Tactical Framework. As this program develops, future versions of this Framework will address JTRS in more detail.

## **U.S. Marine Corps End User Terminal**

The EUT is a technology currently in the testing phase by the U.S. Marine Corps. The EUT provides low bandwidth, networked communications at the squad level. However, the system currently lacks available security solutions. During recent Urban Warrior exercises, the Marines tested an EUT vest, composed of a minilaptop computer running MS Windows, Netscape, and SRI's INCON Common Tactical Picture (CTP) software. These vests use differential Global Positioning System (GPS) for positioning and wireless Ethernet to communicate with one or more wireless access points. The mini-laptops have two PC card slots that are used by the



## UNCLASSIFIED

Information Assurance for the Tactical Environment  
IATF Release 3.1—September 2002

wireless LAN PC card and for cellular phone PC card adapters. Additionally, high-bandwidth wide area network (WAN) connectivity is provided to the CTP via Very Small Aperture Terminal (VSAT) SATCOM and/or leased T1 lines. Thus, all the squads of Marines can access the CTP, including video feeds, intelligence images, and real time-updates. The CTP is also available to helicopters, boat units, light armored vehicles, and reconnaissance forces in the tactical area.

To date, all the Marine Corps Urban Warrior exercises have been unclassified; thus, minimal work has been conducted regarding cryptographic and IA solutions to secure the EUT and CTP software. Early testing has focused on integrating commercial networking technologies onto the tactical battlefield. Future solutions will likely employ some of the same high-assurance software products under development for the JTRS program. For additional information about commercial wireless LAN technologies, refer to the IATF Section 5.2.3, Wireless LAN.

### 9.8.4 Framework Guidance

Tactical users are encouraged to implement network monitoring, intrusion detection, and other IA tools in battlefield and other tactical environment networks. The adversaries of tomorrow will have the network savvy required to attack tactical networks. Detection and prevention of network intrusions will go a long way to insure the security of sensitive communications. Meanwhile, this Framework encourages the development of higher data rate (100s of Mbps) systems available at the lowest warfighter level with enough processing power to implement COTS security solutions in a handheld and man-portable form factor.

## 9.9 Split-Base Operations

Split base refers to a situation in which a unit deploys from its home base to a forward-operating base in or near the battlefield. As the United States decreases the permanent presence of its military forces on foreign soil, the number of such split-base operations will continue to increase. In forward operations, it is preferable to bring along as little infrastructure as possible. The goal is to maximize forward capability. One approach is to leave infrastructure “at home” and rely on communications links to tie the warfighter at the front to the infrastructure at home. However, units must retain the capability to deploy to any site worldwide, bringing an entire suite of equipment to the battlefield that can operate securely, without relying on specific IA tools available at that site. Although the proximity to the battlefield may vary according to the service in question (e.g., Air Force versus Army units), the IA issues relating to split-base operations will generally remain the same. IA concerns for split-base operations actually incorporate several other issues already discussed in this tactical section. However, specific IA issues relating to split-base operations are discussed here because of the importance of secure communications during these types of operations.

To better support split-base operations, the services have programs in place to upgrade the communications infrastructure of military installations worldwide. DoD has embraced the idea

of “network-centric warfare,” where tactical, logistics, and intelligence information becomes as much a weapon for the warfighter as firepower. Joint Vision 2010 puts networks at the center of military strategy for the next decade. Each service has separate programs in place to upgrade and standardize the client/server-based local, metropolitan, and WANs throughout the DoD. These programs are discussed below in the technology assessment area.

Infrastructure upgrades will drastically improve the support for deployed tactical forces, providing the capability to transport high-volume, real-time  $C^2$ , and intelligence data to support contingency deployments and split-base operations during peacetime and war. As a rule of thumb, when a unit (or part of a unit) deploys to a forward area, an immediate demand exists for secure, high-capacity communications back to the main base. Today, most Air Force squadrons will deploy to an existing airbase near the theater of operations where communications capabilities are already in place. However, this is not always the case for tactical ground forces. When a tactical Army unit deploys to an area that does not have an existing communications capability, technologies must be available to enable the rapid setup of secure voice, data, and video communications systems, linking the deployed unit to the home infrastructure. As the networking infrastructure of U.S. bases improves, tactical units must have the capability to connect securely back to their home networks. Tactical forces will likely rely heavily on SATCOM and other wideband systems to provide these secure communications between home base and the TPN forward.

An example from the WIN Master Plan is used to illustrate the split-base operation concept. Today’s equipment does not provide for multilevel security over a single channel. Current security policy for the TPN mandates that all hardware be accredited for secret high operation. (The exception to this policy is the tunneling of Unclassified but Controlled Standard Army Management Information System (STAMIS) users via in-line network encryption (currently, the Network Encryption Systems [NES]) through the deployed TPN. For specific guidance on tunneling of lower classification data over a classified system-high network, refer to Section 5.3.7 in System High Interconnects and VPNs.

Today’s typical configuration, shown in Figure 9-4 taken from the WIN, calls for the use of firewalls at gateway points between network types and High Assurance Guards (HAG) between the Secret Internet Protocol Router Network (SIPRNET) and Nonclassified Internet Protocol Router Network (NIPRNET). Figure 9-5 illustrates the objective configuration implementing

MLS with FORTEZZA<sup>®</sup> or other programmable cryptography at each node. Tactical forces that connect to the TPN need the ability to wirelessly pull information from SIPRNET, NIPRNET, or the Joint Worldwide Intelligence Communications System (JWICS) databases from their deployed location. Improvements to the network infrastructure will improve  $C^2$  in split-base operations. Furthermore, security services such as confidentiality, data integrity, and access control mechanisms become increasingly important for a commander communicating with forward-deployed tactical forces. These services must continue to be a part of the TPN infrastructure.

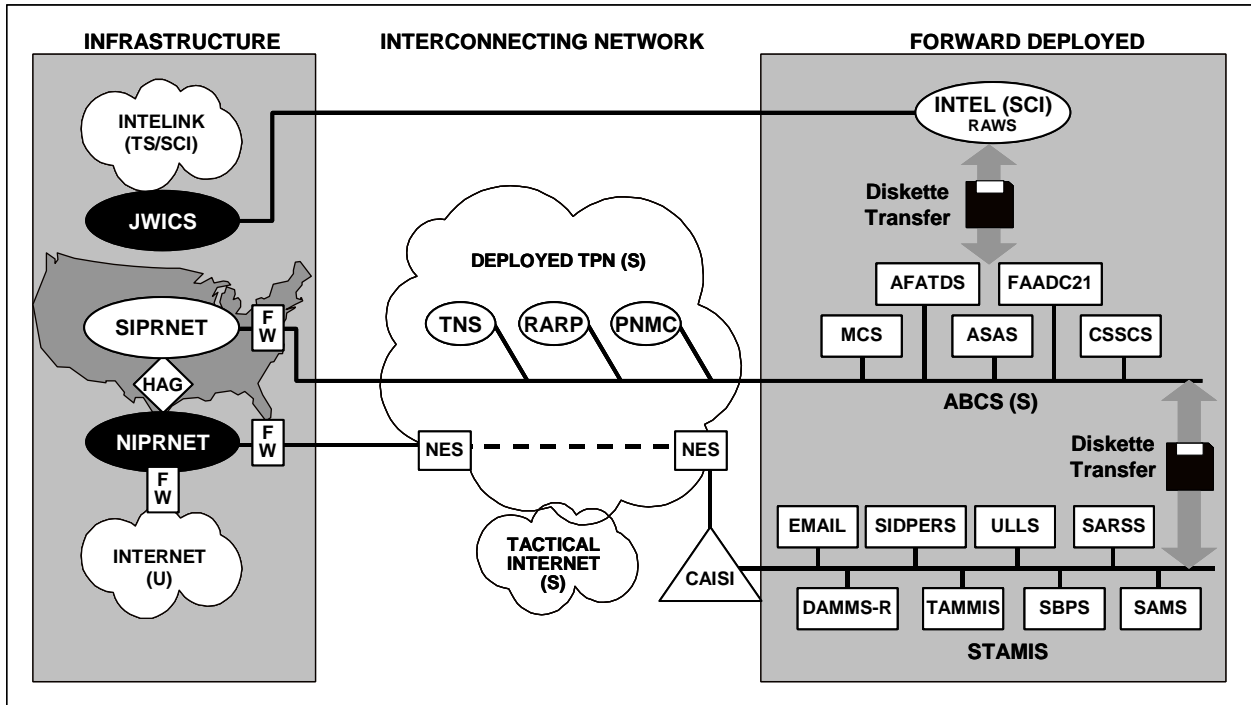

iatf\_9\_4\_0132

Figure 9-4. Near-Term Architecture [11]

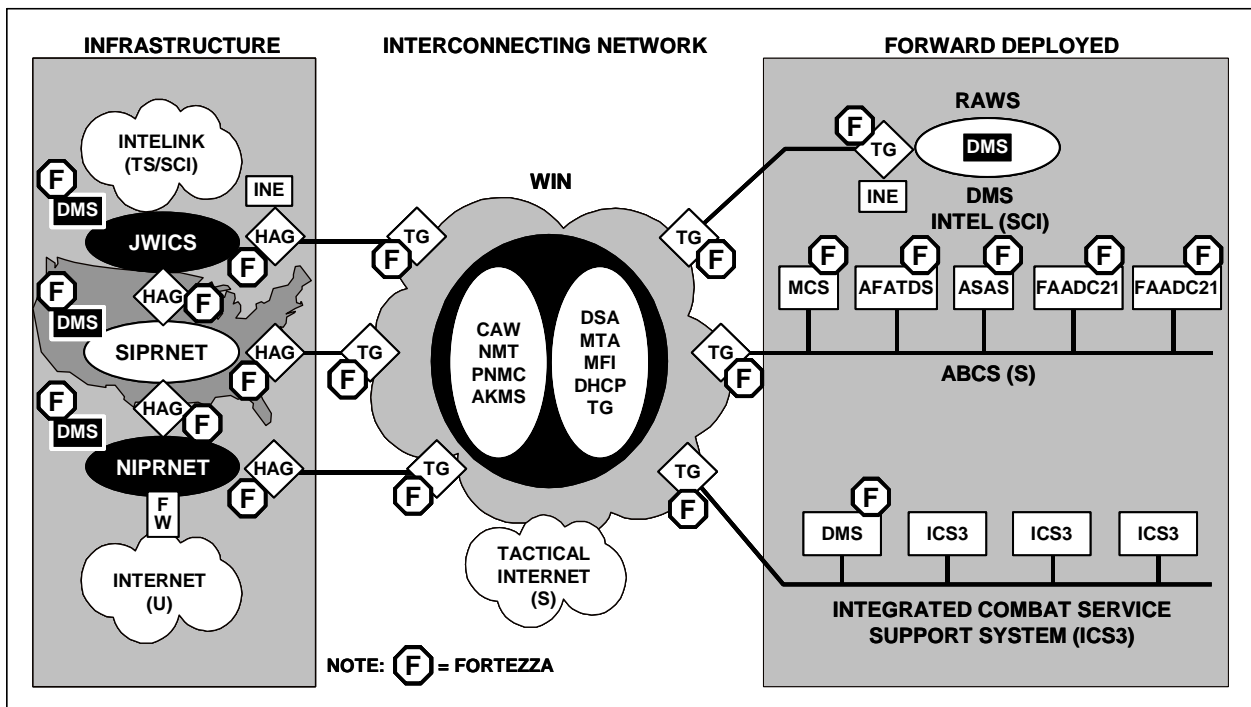

iatf\_9\_5\_0133

Figure 9-5. Objective WIN Security Architecture [11]

As stated previously, many of the IA issues discussed elsewhere in this chapter are particularly applicable to split-base operations.

## 9.9.1 Mission Need

Split-base operations are a culmination of all the tactical IA issues described in this Framework. Each IA issue must be addressed to securely execute the split-base operations described in the WIN and other Joint Vision 2010 documents. Furthermore, as the number of permanent U.S. overseas installations decreases, the separation between “home” and “forward” will more and more often be between CONUS and “forward.” Network technology must provide a robust multimedia, theater-level communications networking infrastructure that can be rapidly deployed to support tactical operations. Several security implications are associated with maintaining communications links between the home base and a deployed location.

As an example, all types of information, from logistical supply data to intelligence data, traverses the communications link between the deployed location and the home base. For a sophisticated adversary with access to transcontinental communications, eavesdropping, disrupting, or denying the communications links necessary for successful split-base operations can give an adversary a significant military advantage.

## 9.9.2 Consolidated Requirements

The goal of a successful split-base operation is to maximize forward capability, while minimizing the amount of infrastructure required at the forward location. Thus, in addition to the requirements listed in the previous sections, the following requirements exist for IA in a tactical split-base operation:

- Infrastructure upgrades must occur in home-base networks to improve the support for deployed tactical forces. These upgrades must provide the capability to transport high-volume, real-time C2, and intelligence data such as battlefield video teleconferencing and transfer of satellite imagery to forward units.
- Tactical units must bring a suite of equipment to the battlefield that can be securely configured at any site, without relying on IA solutions available at that site.
- Technologies must be available to the warfighter at forward locations to enable rapid setup of secure voice, data, and video communications systems.
- IA technologies must be in place to prevent a sophisticated adversary from eavesdropping, disrupting, or denying the communications links necessary for successful split base operations. Proper implementation of security solutions discussed in Chapters 5 through 8 of this IATF can provide adequate protection for a split-base operation.

## 9.9.3 Technology Assessment

Well coordinated split-base operations require a sophisticated communications infrastructure at the base level in the CONUS. Based on guidance from Joint Vision 2010, the services have kicked off several programs aimed at improving this infrastructure at the base level. These programs are discussed below.

The Navy has the Information Technology for the 21st Century (IT-21), which defines a standard, networked computing environment, based on commercial technology, for its ashore and afloat units. Key Army initiatives include the Outside Cable Rehabilitation (OSCAR) program, Common User Installation Transport Network (CUITN), Army's DISN Router Program (ADRP), and Digital Switched Systems Modernization Program (DSSMP). These programs will update the Information Technology (IT) infrastructure at Army facilities in the United States, providing an all-fiber ATM network to support real-time wideband data requirements like video teleconferencing. Finally, the Air Force is implementing a base-level Combat Information Transport System (CITS) that includes installation of fiber-optic cable, ATM switches, hubs, and routers at 108 bases. As a vital part of CITS, information protection hardware and software will be installed as part of an Air Force standard network management system.

### **Theater Deployable Communications Integrated Communications Access Package Program: Rapid Communications Setup in a Drop-in Airbase**

The U.S. Air Force also has contracted to develop a new advanced rapid deployment communications network to be used to deploy critical communications assets at a "drop-in" airbase. The program, called the Theater Deployable Communications Integrated Communications Access Package Program (TDC-ICAP), will provide secure and nonsecure voice, data traffic for local area, intra-theater, and intertheater communications using commercial components. The deployment of the TDC-ICAP will enable all of the U.S. Air Force elements (command and control, intelligence, logistics, and mission support functions) to function in a coordinated manner from initial deployment through sustainment.

The TDC provides a ground-to-ground communications infrastructure designed to transmit and receive voice, data, and video communications securely to or from wireless, satellite, or hard-wired sources. This modular and mobile system will allow the Air Force to tailor the system to its specific needs and to transport the system anywhere worldwide. Thus, TDC-ICAP drastically reduces the communications problems typically associated with airlift and manpower. The system is configured into common man-transportable transit cases to optimize airlift capability and to ease the problem of ground deployment.

TDC-ICAP interfaces with legacy TRI-TAC equipment through an adaptation of existing SMART-T technology developed for the Milstar system. Additionally, the ICAP is compatible with the telephone systems in 39 countries wide, providing connectivity through a commercial

Private Branch eXchange (PBX) to the local phone system. The center of the TDC-ICAP complex is the base hub, which supports all users located at its specific location. Additionally, all off-base communication passes through the base hub for distribution and is handled by the off-base hub for specific interfaces, bulk encryption and decryption, and multiplexing.

The TDC-ICAP provides secure, tactical communications services to forward-deployed Air Force units virtually anywhere worldwide. Rapid deployment of a core communications capability is central to the success of this program. Core communications can be set up in 1.5 hours after the initial pallets of equipment are delivered on site. Access is provided for TRI-TAC KY-68 encryptors. Two-wire and Integrated Services Digital Network (ISDN) interfaces are available at all nodes in the system allowing connection of STU-III or STE terminals for secure voice and secure fax capabilities. In addition, it is designed for transition to Defense Message System (DMS) compatibility, when that system is phased in. [12]

## 9.9.4 Framework Guidance

Split base operations will continue to present new technological challenges to the tactical unit commander. As the communications infrastructure improves, the forward commander will have access to increased bandwidth and unparalleled connectivity to rear-echelon networks. Tactical units will be able to access the NIPRNET and SIPRNET from their forward locations. One key technology gap identified in this framework involves pulling information from the SIPRNET over a wireless link. A commercial PDA user can pull a map off the Internet, get directions, or access a database at the office from virtually anywhere in the country. However, a soldier on the battlefield has no way to access the SIPRNET to pull down a classified map or view overhead imagery. Continued developments in JTRS may help resolve this issue.

## 9.10 Multi-Level Security

As the U.S. military and other agencies with tactical missions move toward the next generation of radios and communications equipment, MLS has become an increasingly important technology hurdle. MLS implies a communications device that can simultaneously process data communications at different levels of classification. A radio on an unclassified network (e.g., HaveQuick in an Air Force network) will need to communicate with both unclassified networks and data systems in a tactical Internet operating at the secret-high level. Interoperability—the exchange of data between different classification levels—has become a necessity. As a result, MLS solutions are needed to integrate the majority of individual military communications systems into an interoperable ensemble of capability. Because of the difficulty involved with fielding a true MLS solution, this section focuses on MLS more as an objective than a requirement.

Traditional security policies mandate strict physical separation of systems and data at different classification levels. However, as the military moves toward a Software Defined Radio (SDR), physical separation is difficult, if not impossible, to achieve. MLS solutions will integrate high-

assurance hardware and high-assurance software solutions, eliminating the need for separate COMSEC devices and red processors at each independent classification level. Integrated MLS solutions yield critical size, weight, and power reductions, lightening the load for a tactical warfighter.

A cornerstone of multi-level security solutions is programmable cryptography. Programmable cryptography is a set of hardware and software capable of changing COMSEC algorithms and keys, allowing one device to interoperate with several different COMSEC devices. Current legacy communications equipment typically uses a COMSEC device particular to that equipment or to the specific channel on which a radio is operating using one COMSEC algorithm at a time. In contrast, programmable cryptography enables communications equipment to load several different COMSEC keys simultaneously, allowing a single radio to “talk” on several different nets without requiring separate COMSEC devices or having to reload COMSEC for each net. In addition, new algorithms can be added via secure software, and old ones can be deleted. Last, upgrades to programmable cryptographic devices are done in software, instead of hardware board replacements of legacy COMSEC equipment. This issue corresponds to Section 9.2, Wiping Classified Data From Tactical Equipment.

### 9.10.1 Mission Need

True multi-level security solutions (at Type 1 security levels) have never been achieved for tactical systems. Communications at different security levels remains a complicated challenge. Separate red processors are required not only at each classification level, but also at separate buses and red devices for each level. Unfortunately for the tactical warfighter, this means more equipment in the field. A transition must be made from secret-high operations to Multiple Independent Security Levels (MILS), and eventually to true multi-level security through the use of programmable cryptography.

A true MLS solution, as proposed in JTRS, would implement a programmable cryptographic chip in a single radio. Several different levels of cryptographic key would be loaded in the same chip, allowing the airborne troops to carry only a single radio into battle, freeing part of their limited load for other items, such as ammunition. Use of programmable cryptography for MLS will increase interoperability between networks at different levels and will decrease critical equipment requirements for the warfighter.

### 9.10.2 Consolidated Requirements

- Multi-level security solutions are needed to integrate the majority of individual military communications systems—increasing interoperability and reducing critical size, weight, and power requirements for the tactical user.
- A transition must be made from secret-high operations to MILS, and eventually to true multi-level security through the use of programmable cryptography.

- Programmable cryptographic solutions used in concert with trusted OS must be available in the future enabling tactical communications systems to enable multiple levels of classified information on a single radio.

## 9.10.3 Technology Assessment

Multi-level security solutions will eventually be implemented in hardware or software or a combination of both. A hardware approach relies on physical separation of data at different classification levels, and it can be difficult to upgrade if modifications become necessary. However, by using a hardware-software combination solution, the hardware effects can be minimized. Hardware elements such as programmable cryptography can be used to eliminate the need for separate COMSEC devices and Red processors at each classification level. Part of this section briefly discusses some of the programmable cryptography programs under development.

In addition, a hardware-software combination MLS design may include use of a trusted OS, coupled with a trusted middleware solution. A high-assurance, software-based data control scheme ensures data separation for different classification levels. The advantages of this type of implementation are flexibility, portability, and minimal hardware dependency. Also, new security technologies can easily be added through software upgrades. A large number of real-time OSs are available. The choice of which OS to use for a particular application should be made judiciously, considering such issues as interoperability and performance parameters. Systems such as JTRS require Portable OS Interface Unix (POSIX) (IEEE 1003) compliance for the OS.

Several major programmable cryptography programs are under way, including AIM, Cornfield, FORTEZZA<sup>®</sup> Plus, Cypris, and the Navy's Programmable Embedded INFOSEC Program (PEIP). Certain devices fit better in different form factors, and allow several channels to operate simultaneously. Specific solutions should be chosen judiciously on a case-by-case basis. This section is not intended to cover each program in detail or to recommend a specific device. Rather, to increase equipment interoperability and decrease the amount of COMSEC equipment required in the field, this Framework encourages continued improvements to current programmable cryptographic devices.

Programmable cryptography on embedded cryptographic chips will help pave the way to achieving full multi-level security solutions. Refer to the earlier discussion about JTRS for an example of a future tactical application of MLS. Programmable cryptography relies on high-assurance components that perform the function of maintaining separation of data at different classification levels. Instead of physical separation, these devices maintain strict data separation within the chip. Successful implementation of these chips in tactical communications equipment will reduce the amount of equipment required in the field and will reduce the number of COMSEC keys and equipment to be maintained in a hostile environment. Coupled with proper media encryption and zeroizing technologies, a true multi-level security solution will significantly enhance the effectiveness of tactical communications.



## 9.10.4 Framework Guidance

True multi-level security solutions do not exist. This Framework encourages continued research in programmable cryptography and in the development of trusted OS, to approach true MLS implementation. The JTRS program has a requirement for MLS operation three to six years down the road. Until then, systems will operate with MILS. As a stepping stone toward MLS, MILS implies multiple classification levels of data in the same system as separate channels. Until true MLS is achieved, tactical units should implement MILS systems and components wherever possible to lighten the equipment load on the warfighter.

## 9.11 Additional Technologies

Given the format of this chapter, certain tactical systems that will play key roles in future tactical communications did not seem to fit any of the specific categories discussed above. Therefore, these systems are discussed here: Tactical STE (TAC/STE), ISYSCON, and Battlefield Video Teleconferencing (BVTC).

### Tactical Secure Telephone Equipment

STE is the next generation of secure voice and data equipment for advanced digital communications networks. The STE consists of a host terminal and a removable security core. The host terminal provides the application hardware and software. The security core is a FORTEZZA<sup>®</sup> Plus Krypton cryptographic card, which provides all the encryption and other security services. The STE is available in two models: Office STE and Tactical STE.

The TAC/STE provides secure tactical and strategic digital multimedia communications, interoperating with legacy TRI-TAC equipment, while also providing basic ISDN and STU-III compatibility in a single unit. The TAC/STE provides direct connection to tactical communication systems in the field and offers full office features and connectivity for use in garrison. The design is based on the open, modular architecture, allowing efficient software upgrades to deployed units. TAC/STE is TRI-TAC/MSE Interoperable and supports 16/32 kbps CVSD clear secure operation via LPC/CELP. In addition, the Tactical STE PCMCIA Cryptography uses a removable FORTEZZA<sup>®</sup> Plus Krypton Card that supports Unclassified but Controlled through Top Secret/Sensitive Compartmented Information (TS/SCI) traffic. For more TAC/STE information, visit <http://ste.securephone.net/>. [13]

### ISYSCON

Any tactical force deployment will require a number of communications networks. MSE, the mainstay for tactical area communications, operates alongside TRI-TAC assemblages. A vital flow of information gathered by the Joint Tactical Information Distribution System (JTIDS) is simultaneously relayed throughout the battlefield for air defense. Enclaves of soldiers will respond to urgent information passed over their combat net radios (CNR). The EPLRS constantly updates and transmits its location information. The complexity and magnitude of these communications networks demand a means of integrating systems control to maximize the

effectiveness and availability of the various systems and to ensure their interoperability. The ISYSCON program provides this tactical area communications management capability.

The ISYSCON program brings a higher level of integrated communications management to theater tactical communications through a common mechanism, complete with automated tools, to seamlessly integrate communications systems at all levels. ISYSCON optimizes the application of standard Army Frequency Management, COMSEC, and Communications-Electronics Operating Instruction (CEOI) modules; provides automatic interfaces to the Battlefield Functional Area Control System (BFACS); and incorporates unique decision aides and embedded training capabilities.

In the near future, joint communications planning and management for regional Commander in Chief (CINCs) and joint forces commanders will be provided by the emerging Joint Network Management System (JNMS). JNMS will facilitate communications network engineering, monitoring, control, and reconfiguration. It also will perform frequency spectrum management and IA management.

## **Battlefield Video Teleconferencing**

Faster processor speeds and improved modulation techniques have boosted the commercial use of VTC dramatically in recent years. Naturally, the desire to make use of this capability has transferred to the tactical battlefield. The BVTC is a state-of-the-art, near full-motion interactive VTC system that enhances coordination and provides an additional combat multiplier to the warfighter. This technology can be applied at many levels through the battlefield. Two areas that will likely see great enhancements by the use of BVTC are warfighter C<sup>2</sup> and telemedicine.

BVTC enhances C<sup>2</sup> by allowing the warfighter to effectively disseminate orders, clearly stating intent. The warfighter can conduct collaborative planning and whiteboarding with subordinate commanders and key staff elements. (See Figure 9-6.)

Medical units are supported by telemedicine from remote deployment areas, where skeletal medical forces receive assistance from specialists at sustaining-base hospitals. Other applications exist at several regional medical centers (Tripler, Walter Reed, and Landstuhl) to provide specialized diagnosis and care to remote medical facilities. Telemedicine will project the valuable expertise and skills of rear-based specialists to forward-deployed medics.

Commercial development of VTC should drive the development of faster, highly capable network VTC applications. With the addition of data integrity and confidentiality mechanisms, VTC should transfer well to tactical applications. The wide bandwidth signals used with BVTC will require high-speed cryptographic solutions. A high-tech adversary could gain battle damage assessment or other sensitive information simply by intercepting a telemedicine BVTC channel. The development of high-speed, reprogrammable cryptography will speed the implementation of the necessary INFOSEC solutions to BVTC.

BVTC components (e.g., cameras, monitors, computers, microphones) are user owned and operated. The features and capabilities employed at each echelon or activity will be based on the

**UNCLASSIFIED**

Information Assurance for the Tactical Environment  
IATF Release 3.1—September 2002

requirements of that specific echelon or activity. The Army's WIN architecture will provide the bandwidth and throughput required to support BVTC for both point-to-point and multipoint conferencing. BVTC capability will be provided to users of the WIN with nominal impact on the remainder of the network.

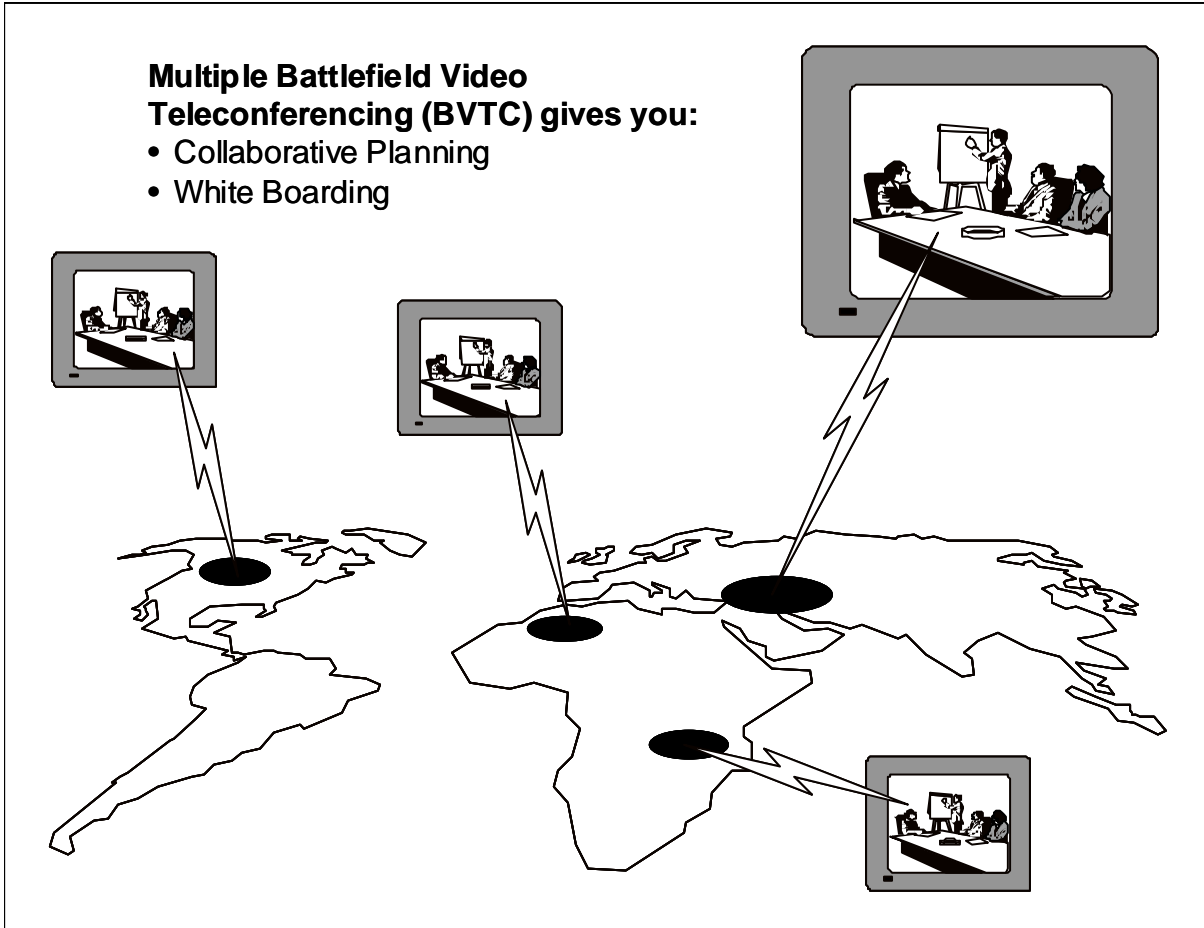

iatf\_9\_6\_0134

**Figure 9-6. Battlefield Video Teleconference**

## UNCLASSIFIED

Information Assurance for the Tactical Environment  
IATF Release 3.1—September 2002

### References

1. Mobile Ad-hoc Networks (MANET) Web Page, <http://www.ietf.org/html.charters/manet-charter.html>.
2. Mobile Ad Hoc Networking Working Group Web Page, <http://www.ietf.org/rfc/rfc2501.txt>.
3. Hewlett Packard Web Site, [http://www.hpl.hp.com/personal/Jean\\_Tourrilhes/MobileIP/](http://www.hpl.hp.com/personal/Jean_Tourrilhes/MobileIP/).
4. BBN Technologies Web Site, <http://www.net-tech.bbn.com>.
5. Deputy Secretary of Defense Memorandum, Department of Defense (DoD) Public Key Infrastructure (PKI), May 6, 1999.
6. DFAS PKI Study, March 10, 1999, <http://www.gradkell.com/PKI/DfasPkiStudy/DfasPkiStudy.PDF>.
7. Condor Wireless Security Web Site, August 9, 2000, <http://condor.securephone.net>.
8. Defense Advanced Research Projects Agency (DARPA) Web Site, August 1, 2000, <http://www.darpa.mil>.
9. Reserved.
10. Brewin, Robert and Daniel Verton. "DoD Leaders Mull Internet Disconnect." *Federal Computer Week*, April 19, 1999.
11. Warfighter Information Network Master Plan, Version 3. 3, June 1997.
12. Motorola Web Site <http://www.mot.com/GSS/SSTG/ISD/ic/TDC.html>.
13. Secure Terminal Equipment (STE) Web Site, August 10, 2000, <http://ste.securephone.net/>.

### Additional References

- a. Network Security Framework, Version 1.1. December 3, 1998.
- b. Shalikashvili, Gen John M. Joint Vision 2010. Joint Chief of Staff: Washington DC, July 1996.
- c. United States Army Communications-Electronics Command. CECOM Vision 2010. New Jersey, 1997.
- d. JBC Information Assurance (IA) Tools for the Joint Task Force (JTF) Phase III Assessment Quicklook Report Summary. February 1999.
- e. Linton, Dennie. Global Broadcast Service: Shrinking the Year-2000 Battlefield by Spreading the Word (Globally).
- f. Fillgrove, Ted. "Update on Enhanced Position-Location Reporting System."
- g. Newton, Harry. Newton's Telecom Dictionary. Telecom Books, October 1998.

## UNCLASSIFIED

Information Assurance for the Tactical Environment  
IATF Release 3.1—September 2002

- h. Marine Corps Operation Urban Warrior Web Page,  
<http://www.defenselink.mil/specials/urbanwarrior/>.
- i. SRI International InCON Web page, <http://www.sri.com/news/releases/05-07-01.html>.

# Chapter 10

## A View of Aggregated Solution

---

This chapter will be provided in a later release of the Framework.

**UNCLASSIFIED**

A View of Aggregated Solution  
IATF Release 3.1—September 2002

**This page intentionally left blank.**

# Appendix A

## Acronyms

---

AAA	Authentication, Authorization and Accounting
AAL 2	ATM Adaptation Layer 2
ACDF	Access Control Decision Function
ACI	Access Control Information
ACL	Access Control List
ACN	Airborne Communications Node
ADRP	Army's DISN Router Program
ADSL	Asymmetric Digital Subscriber Line
ADTN	Agency Data Telecommunications Network
AES	Advanced Encryption Standard
AFIWC	Air Force Information Warfare Center
AH	Authentication Header
AIS	Automated Information System
AJ	Anti-Jam
AMPS	Advanced Mobile Phone Service
AMSC	American Mobile Satellite Corporation
ANSI	American National Standards Institute
ANX	Automotive Network eXchange <sup>®</sup>
API	Application Programming Interface
ASIC	Application-Specific Integrated Circuit
ASCII	American Standard Code for Information Interchange
ASD(C3I)	Assistant Secretary of Defense (Command, Control, Communications, and Intelligence)
ASN.1	Abstract Syntax Notation number One
ASP	Active Server Page
ASW&R	Attack Sensing, Warning, And Response
ATF	Alcohol, Tobacco, and Firearms



## UNCLASSIFIED

Appendix A  
IATF Release 3.1—September 2002

ATM	Asynchronous Transfer Mode
AV	Anti-Virus
BAPI	Biometrics Application Programming Interface
BCA	Bridge Certification Authority
BFACS	Battlefield Functional Area Control System
BFD	Business Forms Division
BIOS	Basic Input/Output System
BIOS ROM	Basic Input/Output System Read Only Memory
BISO	Business Information Security Officer
BN	Backbone Network
BOOTP	Bootstrap Protocol
BSD	Berkeley System Distribution
BVTC	Battlefield Video Teleconferencing
C&A	Certification and Accreditation
C/IMM	Corporate Information Management Model
C2	Command and Control
C4I	Command, Control, Communications, Computers and Intelligence
CA	1. Certification Authority 2. Certificate Authority
CALEA	Communications Assistance for Law Enforcement Act
CAN	Campus Area Network
CAPI	Cryptographic Application Programming Interface
CAT	Common Authentication Technology
CAW	Certificate Authority Workstation
CB	Citizens Band
CBR	1. Constant Bit Rate 2. Case-Based Reasoning
CC	Common Criteria
CCI	Controlled Cryptographic Item
CCITT	Consultative Committee for International Telephone and Telegraph
CD	Compact Disc
CDMA	Code Division Multiple Access

## UNCLASSIFIED

Appendix A  
IATF Release 3.1—September 2002

CDR	Critical Design Review
CD-ROM	Compact Disc-Read Only Memory
CDSA	Common Data Security Architecture
CECOM	Communications Electronics Command
CEM	Common Evaluation Methodology
CEO	Chief Executive Officer
CEOI	Communications-Electronics Operating Instruction
CERT	Computer Emergency Response Team
CFD	Common Fill Device
CGI	Common Gateway Interface
CH	Correspondent Host
CI	1. Cryptographic Interface 2. Configuration Item 3. Capability Increment
CIAC	Computer Incident Advisory Capability
CIDF	Common Intrusion Detection Framework
CIK	1. Crypto-Ignition Key 2. Cryptographic Ignition Key
CINCS	Commanders-in-Chief
CIO	Chief Information Officer
CISO	Corporate Information Security Officer
CITS	Combat Information Transport System
CKL	Compromised Key List
CM	Configuration Management
CMA	Certificate Management Authority
CMI	Certificate Management Infrastructure
CMIP	Common Management Information Protocol
CMM	Capability Maturity Model
CMP	Certificate Management Protocol
CMS	Certificate Management System
CMUA	Certificate Management User Agent
CMW	Compartmented Mode Workstation
CND	Computer Network Defense

## UNCLASSIFIED

Appendix A  
IATF Release 3.1—September 2002

CNR	Combat Net Radio
CO	Central Office
COA	Course of Action
CODEC	Coder/Decoder
COE	Common Operating Environment
COI	Community of Interest
COMPUSEC	Computer Security
COMSEC	Communications Security
CONOP	Concept of Operations; i.e., only one document
CONOPs	Concepts of Operations; i.e., more than one CONOP
CONUS	Continental United States
COO	Chief Operating Officer
CORBA	Common Object Request Broker Architecture
COTS	Commercial-Off-the-Shelf
CP	Certificate Policy
CPS	Certification Practice Statement
CPU	Central Processing Unit
CRADA	Cooperative Research and Development Agreement
CRC	Cyclic Redundancy Check
CRL	Certificate Revocation List
CryptoAPI	Cryptographic Application Programming Interface
CSN	Central Services Node
CSO	Chief Security Officer
CSP	Cryptographic Service Provider
CSRA	Critical Security Requirement Area
CSSM	Common Security Services Manager
CSSM-API	Common Security Services Manager Application Programming Interface
CTP	Common Tactical Picture
CUG	Closed User Group
CUITN	Common User Installation Transport Network
CV	Compliance Validation
CVSD	Continuously Variable Slope Detection

## UNCLASSIFIED

Appendix A  
IATF Release 3.1—September 2002

DA	Directory Administrator
DAA	Designated Approving Authority
DAC	Discretionary Access Control
DAP	Directory Access Protocol
DARPA	Defense Advanced Research Projects Agency
DCOM	Distributed Component Object Model
DEA	Drug Enforcement Agency
DECT	Digital Enhanced Cordless Telecommunications
DEERS	Defense Enrollment Eligibility Reporting System
DER	Distinguished Encoding Rules
DES	Data Encryption Standard
DFAS	Defense Finance and Accounting Service
DGSA	DoD Goal Security Architecture
DHCP	Dynamic Host Configuration Protocol
DIAP	Defense-wide Information Assurance Program
DIB	Directory Information Base
DII	Defense Information Infrastructure
DISA	Defense Information Systems Agency
DISN	Defense Information Systems Network
DIT	Directory Information Tree
DITSCAP	Department of Defense Information Technology Security Certification and Accreditation Process
DLL	Dynamic Link Library
DMS	Defense Message System
DMZ	Demilitarized Zone
DN	Distinguished Name
DNA	Deoxyribonucleic Acid
DNS	Domain Name System
DNSSEC	Domain Name System Security
DoD	Department of Defense
DOE	Department of Energy
DoS	Denial of Service

## UNCLASSIFIED

Appendix A  
IATF Release 3.1—September 2002

DS-0	Digital Service, Level Zero
DSA	Directory System Agent
DSL	Digital Subscriber Line
DSN	Defense Switched Network
DSP	Digital Signal Processing
DSS	Digital Signature Standard
DSSMP	Digital Switched Systems Modernization Program
DSSS	Direct Sequence Spread Spectrum
DTD	Data Transfer Device
E911	Emergency 911
EAL	Evaluation Assurance Level
ECAs	External Certificate Authorities
ECP	Engineering Change Proposal
EEPROM	Electrically Erasable Programmable Read Only Memory
EISL	Embedded Integrity Services Library
EKMS	Electronic Key Management System
E-mail	Electronic Mail
EPLRS	Enhanced Position/Location Reporting System
EPROM	Erasable Programmable Read Only Memory
ESM	Enterprise Security Management
ESNet	1. Department of Energy Science Network 2. Energy Science Network
ESP	Encapsulating Security Payload
ETSI	European Telecommunications Standardization Institute
EUT	End User Terminal
FAA	Federal Aviation Administration
FBI	Federal Bureau of Investigation
FCC	Federal Communications Commission
FDDI	Fiber Distributed-Data Interface
FDMA	Frequency Division Multiple Access
FEDCERT	Federal Computer Emergency Response Team
FEMA	Federal Emergency Management Agency

**UNCLASSIFIED**

Appendix A  
IATF Release 3.1—September 2002

FFC	FORTEZZA ® for Classified
FHSS	Frequency Hopped Spread Spectrum
FIDNet	Federal Intrusion Detection Network
FIPS	Federal Information Processing Standard
FIPS PUB	Federal Information Processing Standards Publication
FIRST	Forum of Incident Response and Security Teams
FNBDT	Future Narrow Band Digital Terminal
FPKI	Federal Public Key Infrastructure
FRF	Frame Relay Forum
FRP	Federal Response Plan
FSRS	Functional Security Requirements Specifications
FTP	File Transfer Protocol
FW	Firewall
GAO	Government Accounting Office
GBS	Global Broadcast System
GCCS	Global Command and Control System
GIF	Graphics Interchange Format
GIG	Global Information Grid
GII	Global Information Infrastructure
GNOSC	Global Network Operations Security Center
GOTS	Government-Off-The-Shelf
GPS	Global Positioning System
GSA	General Services Administration
GSAKMP	Group Service Association Key Management Protocol
GSM	Groupe Speciale Mobile (now known as the Global System for Mobile Communications)
GSS	Generic Security Services
GSS-API	Generic Security Services Application Programming Interface
GUI	Graphical User Interface
GULS	General Upper Layer Security
HAG	High Assurance Guard
HDSL	High Bit-Rate Digital Subscriber Line

## UNCLASSIFIED

Appendix A  
IATF Release 3.1—September 2002

HF	High Frequency
HTI	Harm To Information
HTML	HyperText Markup Language
HTTP	Hypertext Transfer Protocol
I&A	Identification and Authentication
IA	Information Assurance
IATF	Information Assurance Technical Framework
IBAC	Identity Based Access Control
IC	Intelligence Community
ICMP	Internet Control Message Protocol
ICRLA	Indirect Certificate Revocation List Authority
ICSA	International Computer Security Association
ID	Identification
IDEF	Integrated Definition
IDS	Intrusion Detection System
IDUP	Independent Data Unit Protection
IDUP GSS API	Independent Data Unit Protection Generic Security Service Application Program Interface
IEC	International Engineering Consortium
IEEE	Institute of Electrical and Electronics Engineers
IESG	Internet Engineering Steering Group
IETF	Internet Engineering Task Force
IKE	Internet Key Exchange
ILS	Integrated Logistics Support
IMM	Information Management Model
INE	In-line Network Encryptor
INFOCON	Information Condition
INFOSEC	Information Systems Security
INMARSAT	International Maritime Satellite
INS	Immigration and Naturalization Service
IOS	Internet Operating System
IP	Internet Protocol

## UNCLASSIFIED

Appendix A  
IATF Release 3.1—September 2002

IPDC	IP Device Control
IPN	Information Protection Network
IPOC	Initial Point of Contact
IPP	Information Protection Policy
IPSec	Internet Protocol Security
IPX	Internet Packet eXchange
IR	Infrared
IS	Information System
ISA	Intelligent Scanning Architecture
ISAC	Information Sharing and Analysis Center
ISAKMP	Internet Security Association and Key Management Protocol
ISDN	Integrated Services Digital Network
ISM	Iridium Security Module
ISO	1. International Organization for Standardization (Name not Acronym) 2. Information Security Officer
ISP	Internet Service Provider
ISSE	1. Information System Security Engineer 2. Information System Security Engineering
ISSO	1. Information Systems Security Organization 2. Information System Security Officer
IT	Information Technology
IT-21	Information Technology for the 21 <sup>st</sup> Century
ITG	Information Technology Group
ITT	Information Threat Table
ITU	International Telecommunications Union
IW	Information Warfare
JNMS	Joint Network Management System
JPO	Joint Program Office
JTF-CND	Joint Task Force for Computer Network Defense
JTIDS	Joint Tactical Information Distribution System
JTRS	Joint Tactical Radio System
JWICS	Joint Worldwide Intelligence Communications System
Kbps	Kilobits Per Second



## UNCLASSIFIED

Appendix A  
IATF Release 3.1—September 2002

KMI	Key Management Infrastructure
KMI/PKI	Key Management Infrastructure/Public Key Infrastructure
Exchange KMS	Exchange Key Manager Server
KP	Key Processor
KRA	Key Recovery Agent
KRB	Key Recovery Block
KRF	Key Recovery Field
KRI	Key Recovery Information
LAN	Local Area Network
LCA	Legal And Corporate Affairs
LCC	Life-Cycle Costing
LDAP	Lightweight Directory Access Protocol
LEO	Low Earth Orbit
LMD/KP	Local Management Device/Key Processor
LMR	Land Mobile Radio
LOS	Line-Of-Site
LPC/CELP	Linear Predictive Coding/Codebook Excited Linear Prediction
LPD	Low Probability of Detection
LPI	Low Probability of Intercept
LRA	Local Registration Authority
LSE	Local Subscriber Environment
MAC	1. Mandatory Access Control 2. Media Access Control
MAIS	Major Automated Information System
MAN	Metropolitan Area Network
MANET	Mobile Ad Hoc Networking
MATTS	Mobile Air Transportable Telecommunications System
MBR	Model-Based Reasoning
MCS	Maneuver Control System
MCU	Multipoint Control Unit
MD4	Message Digest 4
MD5	Message Digest 5

UNCLASSIFIED

MDAP	Major Defense Acquisition Programs
Megaco	Media Gateway Control
MEO	Medium Earth Orbit
MERS	Mobile Emergency Response Support
MG	Media Gateway
MGC	Media Gateway Controller
MGCP	Media Gateway Control Protocol
MHS	Message Handling System
MHz	Megahertz
MIB	Management Information Base
MIL STD	Military Standard
MILDEP	Military Department
MILS	Multiple, Independent Security Levels
MILSATCOM	Military Satellite Communications
MIME	Multipurpose Internet Mail Extensions
MISSI	MISSI, it's a set of historical IA concepts. It is part of an Internet address and part of the name of a protocol; i.e., MMP.
MIT	Massachusetts Institute of Technology
MLN	Multilevel Network
MLS	Multilevel Security
MMP	MISSI Management Protocol
MNS	Mission Needs Statement
MOB	Main Operating Base
MPEG	Moving Pictures Expert Group
MSE	Mobile Subscriber Equipment
MSP	Message Security Protocol
MSROOT	Microsoft Root Authority
MSS	1. Mobile Satellite Subscriber 2. Mobile Satellite Service
MTA	Message Transfer Agent
MTBF	Mean Time Between Failure
MTS	1. Mail Transfer System 2. Message Transfer System

## UNCLASSIFIED

Appendix A  
IATF Release 3.1—September 2002

MTSC	Mobile Telephone Switching Center
MTTR	Mean Time to Repair
NAT	Network Address Translation
NATO	North Atlantic Treaty Organization
NAVCERT	Navy Computer Emergency Response Team
NBC	Nuclear, Biological, and Chemical
NCO	Non-Commissioned Officer
NES	Network Encryption System
NETBIOS	Network Basic Input/Output System
NIAP	National Information Assurance Partnership
NIC	Network Interface Card
NII	National Information Infrastructure
NIPC	National Infrastructure Protection Center
NIPRNET	Non-classified Internet Protocol Router Network
N-ISDN	Narrowband Integrated Services Digital Network
NIST	National Institute of Standards and Technology
NMC	Network Management Center
NNTP	Network News Transfer Protocol
NORAD	North American Aerospace Defense
NOS	Network Operating System
NS/EP	National Security/Emergency Preparedness
NSA	National Security Agency
NSF	Network Security Framework
NSIRC	National Security Incident Response Center
NSTISSP	National Security Telecommunications and Information Systems Security Policy
OA&M	Operations, Administration and Maintenance
OAN	Operational Area Network
OASD(C3I)	Office of the Assistant Secretary of Defense (Command, Control, Communications and Intelligence)
OCSP	On-Line Certificate Status Protocol
OO	Object-Oriented

**UNCLASSIFIED**

Appendix A  
IATF Release 3.1—September 2002

OPSEC	Operational Security
ORD	Operational Requirements Document
OS	Operating System
OSCAR	Outside Cable Rehabilitation
OSD	Office of the Secretary of Defense
OSI	Open Systems Interconnection
OTAR	Over-the-Air Rekey
OTAT	Over-the-Air Transfer
OTAZ	Over-the-Air Zeroize
PAA	Policy Approving Authority
PBX	Private Branch eXchange
PC	Personal Computer
PCA	Policy Creation Authority
PCI	Protocol Control Information
PCM	Pulse Code Modulation
PCMCIA	Personal Computer Memory Card International Association
PCS	Personal Communications System
PDA	Personal Digital Assistant
PDD	Presidential Decision Directive
PDD-63	Presidential Decision Directive 63
PDF	Portable Document Format
PDR	Preliminary Design Review
PEIP	Programmable Embedded INFOSEC Program
PERL	Practical Extraction and Report Language
PGP	Pretty Good Privacy
PHE	Potentially Harmful Events
PHS	Personal Handyphone System
PIN	Personal Identification Number
PK	Public Key
PKCS	Public Key Cryptographic Standards
PKI	Public Key Infrastructure
PM	Privilege Manager

## UNCLASSIFIED

Appendix A  
IATF Release 3.1—September 2002

PMA	Policy Management Authority
PMO	Program Management Office
PN	Public Network
PNA	Protection for Network Access
PNE	Protection Needs Elicitation
POP	1. Post Office Protocol 2. Proof of Possession
POSIX	Portable Operating System Interface Unix
POTS	Plain Old Telephone Service
PP	Protection Profile
PPP	Point-to-Point Protocol
PROM	Programmable Read Only Memory
PRS	Product Release Services
PRSN	Primary Services Node
PSN	Production Source Node
PSTN	Public Switched Telephone Network
PVC	Permanent Virtual Connection
QOP	Quality of Protection
QOS	Quality of Service
R&D	Research and Development
RA	Registration Authority
RADIUS	Remote Access Dial In User Service
R-ADSL	Rate-Adaptive Digital Subscriber Line
RAM	Random Access Memory
RAS	Registration Admission Status
RBAC	Rule Based Access Control
RBR	Rule-Based Reasoning
RDN	Relative Distinguished Name
RF	Radio Frequency
RFC	Request for Comments
RFP/RFQ	Request for Proposals/Requests for Quotes
RIM	Recovery Information Medium

## UNCLASSIFIED

Appendix A  
IATF Release 3.1—September 2002

RM	Registration Manager
RMON	Remote Monitor
ROM	Read Only Memory
RSVP	Resource Reservation Setup Protocol
RTCP	Real-Time Transport Control Protocol
RTP	Real-Time Transport Protocol
S/MIME	Secure/Multipurpose Internet Mail Extensions
SA	System Administrator
SABI	Secret and Below Interoperability
SATCOM	Satellite Communications
SC	Steering Committee
SCIF	Sensitive Compartmented Information Facility
SD	Systems Division
SDD	Secure Data Device
SDE	Secure Data Exchange
SDLS	Single-Line Digital Subscriber Line
SDR	Software Defined Radio
SE	Systems Engineering
SEP	Systems Engineering Process
SET	Secure Electronic Transaction
S-FTP	Secure File Transfer Protocol
SFUG	Security Features Users Guide
SGCP	Simple Gateway Control Protocol
S-HTTP	Secure Hypertext Transfer Protocol
SID	System Identification
SIM	Subscriber Identity Module
SINCGARS	Single Channel Ground and Airborne Radio System
SIP	Session Initiation Protocol
SIPPING	Session Initiation Protocol Project Investigation
SIPRNET	Secret Internet Protocol Router Network
SKM	Symmetric Key Management
SLA	Service Level Agreement

## UNCLASSIFIED

Appendix A  
IATF Release 3.1—September 2002

SLIP	Serial Line Internet Protocol
SMB	Server Message Block
SMDS	Switched Multi-Megabit Data Service
SMI	Security Management Infrastructure
SMIB	Security Management Information Base
SML	Strength of Mechanism Level
SMTP	Simple Mail Transfer Protocol
SNMP	Simple Network Management Protocol
SONET	Synchronous Optical NETwork
SPG	Security Program Group
SPI	Service Provider Interface
SPKI	Simple Public Key Infrastructure
SQL	Structured Query Language
SS7	Signaling System 7
SSA	System Security Administrator
SSAA	System Security Authorization Agreement
SSAPI	Security Service Application Programming Interface
SSE CMM	System Security Engineering Capability Maturity Model
SSH	Secure Shell
SSL	Secure Sockets Layer
SSM	System Security Manager
SST-3	Synchronous Service Transport, Level Three
ST	Security Target
ST&E	Security Test and Evaluation
STAMIS	Standard Army Management Information System
STE	Secure Telephone Equipment
STG	State Transition Graph
STS	Synchronous Transport Service
STS-3	Synchronous Transport Signal 3
STU	Secure Telephone Unit
STU-III	Secure Telephone Unit Third Generation
SVC	Switched Virtual Circuit

**UNCLASSIFIED**

Appendix A  
IATF Release 3.1—September 2002

TAC/STE	Tactical Secure Telephone Equipment
TCB	Trusted Computing Base
TCP	Transmission Control Protocol
TCP/IP	Transmission Control Protocol/Internet Protocol
TDC-ICAP	Theater Deployable Communications Integrated Communications Access Package
TDMA	Time Division Multiple Access
TDY	Temporary Duty
TISM	TACLANE Internet Security Manager
TLS	Transport Layer Security
TOC	Tactical Operations Center
TOE	Target of Evaluation
TPEP	Trusted Product Evaluation Program
TPN	Tactical Packet Network
TRANSCOM	Transportation Command
TRANSEC	Transmission Security
TRI-TAC	Tri-Tactical (Joint Tactical Communications Program)
TS	Top Secret
TSABI	Top Secret and Below Interoperability
TSDM	Trusted Software Design Methodology
TSP	Telecommunications Service Provider
TS-SCI	Top Secret-Sensitive Compartmented Information
TTP	Trusted Third Party
TWG	Technical Working Group
U	Unclassified
U.S.	United States
U//FOUO	Unclassified//For Official Use Only
UAV	Unmanned Aerial Vehicle
UC	University of California
UDP	User Datagram Protocol
UHF	Ultra-High Frequency
UPS	Uninterruptible Power Supply



## UNCLASSIFIED

Appendix A  
IATF Release 3.1—September 2002

URL	Universal Resource Locator
VA	Veterans Affairs
VBA	Visual BASIC Application
VDSL	Very High Bit-Rate Digital Subscriber Line
VHF	Very-High Frequency
VM	Virtual Machine
VoFR	Voice Over Frame Relay
VoIP	Voice Over Internet Protocol
VPN	Virtual Private Network
VRML	Virtual Reality Modeling Language
VSAT	Very Small Aperture Terminal
VTC	Video Teleconferencing
WAIS	Wide-Area Information Service
WAN	Wide Area Network
WIN	Warfighter Information Network or Wireless Intelligent Network
WLAN	Wireless Local Area Network
WLL	Wireless Local Loop
WWW	World Wide Web
X	X Window System
XYZ BFD	XYZ Corporation Business Forms Division
YESSIR	Yet Another Sender Session Internet Reservations

# Appendix B

## Glossary

---

The IATF uses Information Assurance terms defined in National Security Telecommunication and Information Systems Security Instruction (NSTISSI) No. 4009, National Information Systems Security (INFOSEC) Glossary. This document can be obtained from The Committee on National Security Systems (CNSS) website (<http://www.nstissc.gov/Assets/pdf/4009.pdf>). Note, the CNSS was formally known as National Security Telecommunications and Information Systems Security Committee. This glossary defines terminology not available in the NSTISSI No. 4009 and may further expand upon terminology from the NSTISSI No. 4009.

Advanced Mobile Phone Service (AMPS)	The standard system for analog cellular telephone service in the U.S. AMPS allocates frequency ranges within the 800 – 900 MHz spectrum to cellular telephones. Signals cover an area called a cell. Signals are passed into adjacent cells as the user moves to another cell. The analog service of AMPS has been updated to include digital service.
Anonymity	Anonymity is the fact of being anonymous. To provide anonymity, a system will use a security service that prevents the disclosure of information that leads to the identification of the end users. An example is anonymous e-mail that has been directed to a recipient through a third-party server that does not identify the originator of the message.
Application-Level Firewall	A firewall system in which service is provided by processes that maintain complete TCP connection state and sequencing; application level firewalls often re-address traffic so that outgoing traffic appears to have originated from the firewall, rather than the internal host. In contrast to packet filtering firewalls, this firewall must have knowledge of the application data transfer protocol and often has rules about what may be transmitted and what may not.
Application Program Interface (API)	An application program interface (API) is the specific method prescribed by a computer operating system or by an application program by which a programmer writing an application program can make requests of the operating system or another application. An API can be a set of standard software interrupts, calls, and data formats that application programs use to initiate contact with network services, mainframe communications programs, telephone equipment, or program-to-program communications.

## UNCLASSIFIED

Appendix B  
IATF Release 3.1—September 2002

Asymmetric Cryptographic Algorithm	An encryption algorithm that requires two different keys for encryption and decryption. These keys are commonly referred to as the public and private keys. Asymmetric algorithms are slower than symmetric algorithms. Furthermore, speed of encryption may be different than the speed of decryption. Generally asymmetric algorithms are either used to exchange symmetric session keys or to digitally sign a message. RSA, RPK, and ECC are examples of asymmetric algorithms.
Asynchronous Transfer Mode (ATM)	ATM (asynchronous transfer mode) Is a fast cell-switched technology based on a fixed-length 53-byte cell. All broadband transmissions (whether audio, data, imaging or video) are divided into a series of cells and routed across an ATM network consisting of links connected by ATM switches (Newton's Telecom Dictionary).
Authentication Header (AH)	An IP device used to provide connectionless integrity and data origin authentication for IP datagrams.
Authentication Token	See token.
CERT	Computer Emergency Response Team – A federally funded research and development center at Carnegie Mellon University. They focus on Internet security vulnerabilities, provide incident response services to sites that have been the victims of attack, publish security alerts, research security and survivability in wide-area-networked computing, and develop site security information. They can be found at <a href="http://www.cert.org">http://www.cert.org</a> .
Code Division Multiple Access (CDMA)	CDMA (code-division multiple access) refers to any of several protocols used in wireless communications. As the term implies, CDMA is a form of multiplexing, which allows numerous signals to occupy a single transmission channel, optimizing the use of available bandwidth. The technology is used in ultra-high-frequency (UHF) cellular telephone systems in the 800-MHz and 1.9-GHz bands.
Common Criteria (CC)	The Common Criteria represents the outcome of a series of efforts to develop criteria for evaluation of IT security that are broadly useful within the international community. The Common Criteria is an International Standard (IS 15408) and is a catalog of security functionality and assurance requirements
Compromised Key List (CKL)	A list with the Key Material Identifier (KMID) of every user with compromised key material; key material is compromised when a card and its personal identification number (PIN) are uncontrolled or the user has become a threat to the security of the system.

## UNCLASSIFIED

Appendix B  
IATF Release 3.1 —September 2002

Computer Intrusion	An incident of unauthorized access to data or an Automated Information System (AIS).
Cryptographic Application Program Interface	A standardized interface to cryptographic functionality. Also see API.
Cryptographic Function	A set of mathematical procedures that provide various algorithms for key generation, random number generation, encryption, decryption, and message digesting.
Customer	The party, or his designee, responsible for the security of designated information. The Customer works closely with an ISSE. Also referred to as the user.
Defense in Depth	An approach for establishing an adequate IA posture whereby (1) IA solutions integrate people, technology and operations; (2) IA solutions are layered within and among IT assets; and (3) IA solutions are selected based on their relative level of robustness. Implementation of this approach recognizes that the highly interactive nature of information systems and enclaves creates a shared risk environment; therefore, the adequate assurance of any single asset is dependent upon the adequate assurance of all interconnecting assets.
Defense-wide Information Assurance Program (DIAP)	The Defense-wide Information Assurance Program, established in January 1998, is the Office of the Secretary of Defense (OSD) mechanism to plan, monitor, coordinate, and integrate IA activities. The DIAP will act as a facilitator for program execution by the Commanders-in-Chief (CINCs), Military Service and Defense Agencies. The DIAP Staff combines functional and programmatic skills for a comprehensive Defense-wide approach to IA. The Staff's continuous development and analysis of IA programs and functions will provide a "big picture" of the Department's IA posture that identifies redundancies, incompatibilities and general shortfalls in IA investments, and deficiencies in resources, functional and operational capabilities.
DoD Information Technology Security Certification and Accreditation Process (DITSCAP)	The DITSCAP (DoDI 5200.40) defines a process that standardizes all activities leading to a successful accreditation. The principal purpose of that process is to protect and secure the entities comprising the DII. Standardizing the process will minimize risks associated with nonstandard security implementations across shared infrastructure and end systems.

## UNCLASSIFIED

Appendix B  
IATF Release 3.1—September 2002

Downgrade	The change of a classification label to a lower level without changing the contents of the data. Downgrading occurs only if the content of a file meets the requirements of the sensitivity level of the network for which the data is being delivered.
Eavesdropping	An attack in which an attacker listens to a private communication. The best way to thwart this attack is by making it very difficult for the attacker to make any sense of the communication by encrypting all messages.
Effective Key Length	A measure of strength of a cryptographic algorithm, regardless of actual key length.
Encapsulating Security Payload	This message header is designed to provide a mix of security services that provides confidentiality, data origin authentication, connectionless integrity, an anti-replay service, and limited traffic flow confidentiality.
Evaluation Assurance Level (EAL)	One of seven increasingly rigorous packages of assurance requirements from CC (Common Criteria (IS 15408)) Part 3. Each numbered package represents a point on the CC's predefined assurance scale. An EAL can be considered a level of confidence in the security functions of an IT (information-technology) product or system.
Frequency Division Multiple Access (FDMA)	FDMA (frequency division multiple access) is the division of the frequency band allocated for wireless cellular telephone communication into 30 channels, each of which can carry a voice conversation or, with digital service, carry digital data. FDMA is a basic technology in the analog Advanced Mobile Phone Service (AMPS), the most widely installed cellular phone system installed in North America. With FDMA, each channel can be assigned to only one user at a time. FDMA is also used in the Total Access Communication System (TACS).
Future Narrow Band Digital Terminal (FNBDT)	FNBDT is an end-to-end secure signaling protocol that will allow establishment of communications interoperability among communications devices that share the same communications capabilities, but are not configured to communicate with each other. FNBDT sets the common configuration. It is a network-independent/transport-independent message layer. FNBDT operates in the Narrow Band portion of the STE spectrum (64 kbps and below).
Global Information Grid (GIG)	It is a globally interconnected, end-to-end set of information capabilities, associated processes and personnel for collecting, processing, storing, disseminating, and managing information on demand to warfighters, policy makers, and support personnel.

## UNCLASSIFIED

Appendix B  
IATF Release 3.1 —September 2002

Global Command and Control system (GCCS)	A comprehensive, worldwide network of systems that provide the NCA, Joint staff, combatant and functional unified commands, services, and defense agencies, Joint Task Forces and their service components, and others with information processing and dissemination capabilities necessary to conduct C2 of forces.
Global Network Information Environment (GNIE)	A composition of all information system technologies used to process, transmit, store, or display DoD information. GNIE has been superseded by Global Information Grid (GIG).
Host-based Security	The technique of securing an individual system from attack; host-based security is operating system and version dependent.
Identification & Authentication (I&A)	Identity of an entity with some level of assurance.
Information Protection Policy	See Security Policy.
Information Systems Security Engineering (ISSE)	The art and science of discovering users' information protection needs and then designing and making information systems, with economy and elegance, so they can safely resist the forces to which they may be subjected.
Information Technology (IT)	The hardware, firmware, and software used as part of the information system to perform DoD information functions. This definition includes computers, telecommunications, automated information systems, and automatic data processing equipment as well as any assembly of computer hardware, software, and/or firmware configured to collect, create, communicate, compute, disseminate, process, store and/or control data or information.
Insider Attack	An attack originating from inside a protected network.
Internet Control Message Protocol – ICMP	A message control and error-reporting protocol between a host server and a gateway to the Internet. ICMP is used by a device, often a router, to report and acquire a wide range of communications-related information.
Intrusion Detection	Detection of break-ins or break-in attempts either manually or via software expert systems that operate on logs or other information available on the network.

## UNCLASSIFIED

Appendix B  
IATF Release 3.1—September 2002

Intrusion Detection System (IDS)	A system that detects and identifies unauthorized or unusual activity on the hosts and networks; this is accomplished by the creation of audit records and checking the audit log against the intrusion thresholds.
Key Management Infrastructure (KMI)	Framework established to issue, maintain, and revoke keys accommodating a variety of security technologies, including the use of software.
Labeling	Process of assigning a representation of the sensitivity of a subject or object
Layered Solution	The judicious placement of security protections and attack countermeasures that can provide an effective set of safeguards that are tailored to the unique needs of a customer's situation.
Local Area Network (LAN)	A limited distance, high-speed data communication system that links computers into a shared system (two to thousands) and is entirely owned by the user. Cabling typically connects these networks.
Mission Needs Statement (MNS)	Describes the mission need or deficiency; identifies threat and projected threat environment
Motivation	The specific technical goal that a potential adversary wants to achieve by an attack, e.g., gain unauthorized access, modify, destroy or prevent authorized access.
Multipurpose Internet Mail Extensions (MIME)	A specification for formatting non-ASCII messages so that they can be sent over the Internet. MIME enables graphics, audio, and video files to be sent and received via the Internet mail system. In addition to e-mail applications, Web browsers also support various MIME types. This enables the browser to display or output files that are not in HTML format. The Internet Engineering Task Force (IETF) defined MIME in 1992. See also Secure Multipurpose Internet Mail Extensions, S/MIME.
National Information Assurance Partnership (NIAP)	NIAP is a collaboration between the National Institute of Standards and Technology (NIST) and the National Security Agency (NSA) with a goal to help increase the level of trust consumers have in their information systems and networks through the use of cost-effective security testing, evaluation, and validation programs.
Non-Technical Countermeasure	A security measure, that is not directly part of the network information security processing system, taken to help prevent system vulnerabilities. Non-technical countermeasures encompass a broad range of personnel measures, procedures, and physical facilities that can deter an adversary from exploiting a system.

Open System Interconnection Model (OSI)	A reference model of how messages should be transmitted between any two endpoints of a telecommunication network. The process of communication is divided into seven layers, with each layer adding its own set of special, related functions. The seven layers are the application layer, presentation, session, transport, network, data, and physical layer. Most telecommunication products tend to describe themselves in relation to the OSI model. The OSI model is a single reference view of communication that provides a common ground for education and discussion.
Perimeter-based Security	The technique of securing a network by controlling accesses to all entry and exit points of the network.
Pretty Good Privacy (PGP)	A standard program for securing e-mail and file encryption on the Internet. Its public-key cryptography system allows for the secure transmission of messages and guarantees authenticity by adding digital signatures to messages.
Protection Needs Elicitation (PNE)	Discovering the customer's prioritized requirements for the protection of information.
Protection Profile (PP)	A Common Criteria term for a set of implementation-independent security requirements for a category of Targets of Evaluation (TOEs) that meet specific consumer needs.
Risk Plane	A graphic technique for depicting the likelihood of particular attacks occurring and the degree of consequence to an operational mission.
Robustness	A characterization of the strength of a security function, mechanism, service, or solution, and the assurance (or confidence) that is implemented and functioning correctly.
Sanitization –	The changing of content information in order to meet the requirements of the sensitivity level of the network to which the information is being sent.
Secret Key	A key used by a symmetric algorithm to encrypt and decrypt data.
Secure Hash	A hash value such that it is computationally infeasible to find a message which corresponds to a given message digest, or to find two different messages which produce the same digest. See FIPS PUB 180 Federal Information Processing Standards Publication 180, dated May 11, 1993.



## UNCLASSIFIED

Appendix B  
IATF Release 3.1—September 2002

Secure Multipurpose Internet Mail Extensions—S/MIME	A version of the MIME protocol that supports encrypted messages. S/MIME is based on RSA's public-key encryption technology. See also Multipurpose Internet Mail Extensions, MIME.
Security Management Infrastructure (SMI)	A set of interrelated activities providing security services needed by other security features and mechanisms; SMI functions include registration, ordering, key generation, certificate generation, distribution, accounting, compromise recovery, re-key, destruction, data recovery, and administration.
Security Policy	What security means to the user; a statement of what is meant when claims of security are made. More formally, it is the set of rules and conditions governing the access and use of information. Typically, a security policy will refer to the conventional security services, such as confidentiality, integrity, availability, etc., and perhaps their underlying mechanisms and functions.
Security Target (ST)	A set of security requirements and specifications drawn from the Common Criteria for Information Technology Security Evaluation (CC) to be used as the basis for evaluation of an identified TOE.
Session Key	A temporary symmetric key that is only valid for a short period. Session keys are typically random numbers that can be chosen by either party to a conversation, by both parties in cooperation with one another, or by a trusted third party.
Signature [Digital, Electronic]	A process that operates on a message to assure message source authenticity and integrity, and may be required for source non-repudiation.
Social Engineering	An attack based on deceiving users or administrators at the target site and is typically carried out by an adversary telephoning users or operators and pretending to be an authorized user, to attempt to gain illicit access to systems.
SOCKS	A networking proxy protocol that enables full access across the SOCKS server from one host to another without requiring direct IP reachability. The SOCKS server authenticates and authorizes the requests, establishes a proxy connection, and transmits the data. SOCKS is commonly used as a network firewall that enables hosts behind a SOCKS server to gain full access to the Internet, while preventing unauthorized access from the Internet to the internal hosts.

## UNCLASSIFIED

Appendix B  
IATF Release 3.1 —September 2002

Strength of Mechanism (SML)	A scale for measuring the relative strength of a security mechanism hierarchically ordered from SML 1 through SML 3.
Symmetric Algorithm	An algorithm where the same key can be used for encryption and decryption.
System Security Authorization Agreement (SSAA)	The SSAA is the formal agreement among the DAA(s), Certifier, user representative, and program manager. It is used throughout the entire DITSCAP to guide actions, document decisions, specify IA requirements, document certification tailoring and level-of-effort, identify potential solutions, and maintain operational systems security.
Tamper	Unauthorized modification that alters the proper functioning of cryptographic or automated information system security equipment in a manner that degrades the security or functionality it provides.
Target of Evaluation (TOE)	A Common Criteria term for an IT product or system and its associated administrator and user guidance documentation that is the subject of a security evaluation.
Technical Countermeasure	A security feature implemented in hardware and/or software, that is incorporated in the network information security processing system.
Technology Gap	A technology that is needed to mitigate a threat at a sufficient level but is not available.
Time Division Multiple Access (TDMA)	A technique to interweave multiple conversations into one transponder so as to appear to get simultaneous conversations.
Token	A token is an object that represents something else, such as another object (either physical or virtual). A security token is a physical device, such as a special smart card, that together with something that a user knows, such as a PIN, will enable authorized access to a computer system or network.
Trusted Operating System	A Trusted Operating System is part of a Trusted Computer Base (TCB) that has been evaluated at an assurance level necessary to protect the data that will be processed. See the definitions for Trusted Computing Base and Trusted Computer System provided below.

## UNCLASSIFIED

Appendix B  
IATF Release 3.1—September 2002

Trusted Computing Base (TCB)	"The totality of protection mechanisms within a computer system -- including hardware, firmware, and software -- the combination of which is responsible for enforcing a security policy. A TCB consists of one or more components that together enforce a unified security policy over a product or system. The ability of a trusted computing base to correctly enforce a security policy depends solely on the mechanisms within the TCB and on the correct input by system administrative personnel of parameters (e.g., a user's clearance) related to the security policy." [ Page 112 of the Orange Book]
Trusted Computer System	"A system that employs sufficient hardware and software integrity measures to allow its use for processing simultaneously a range of sensitive or classified information." [ Page 112 of the Orange Book]
Tunneling Router	A router or system capable of routing traffic by encrypting it and encapsulating it for transmission across an untrusted network, for eventual de-encapsulation and decryption.
Virtual Network Perimeter	A network that appears to be a single protected network behind firewalls, which actually encompasses encrypted virtual links over untrusted networks.
Wide Area Network (WAN)	A data communications network that spans any distance and is usually provided by a public carrier. Users gain access to the two ends of the circuit and the carrier handles the transmission and other services in between.

# Appendix C

## Characterization of Customer Community Networks

---

- Table C-1. Public/Commercial Networks (Satellites)
- Table C-2. Public/Commercial Networks
- Table C-3. DoD Networks
- Table C-4. Networking Technologies

**UNCLASSIFIED**

Appendix C  
IATF Release 3.1—September 2002

**Table C-1. Public/Commercial Networks (Satellites)**

<b>Acronym</b>	<b>Full Name</b>	<b>Used By</b>	<b>Purpose</b>	<b>User Bandwidth</b>	<b>Multiple Access Methods</b>
Globalstar	Globalstar Partnership	International long-haul communication, vehicle op., traveling national and international	LEO satellite; digital; wireless telecom; extend terrestrial cellular	Digital voice and data; 2400–9600 bps	CDMA/FDMA
Iridium	Iridium	Enhanced mobile satellite systems market focus	66 LEO satellites; provide use of portable satellite phones	2.4 kbps–4.8 kbps	TDMA/FDMA
AMSC	American Mobile Satellite Corp.	United States, Puerto Rico, Virgin Islands, 200 miles of coastal waters; land mobile, fixed site, and aeronautical users	Mobile communications for voice, data, digital broadcast dispatch	1.2 kbps–4.8 kbps	FDMA
Ellipso	Ellipsat	Global mobile communication market	LEO; global voice and data services for access to unserved and remote areas	300–9600 bps	CDMA
Inmarsat	International Maritime Satellite Org.	Global personal mobile satellite communication	MEO; satellite communication for commercial emergency and safety app.	Primary modes Mode “A” - 2.4 kbps–9.6 kbps Mode “B” - Digital 0 to 4.8 kbps Mode “M4” - ISDN, 0 to 128 kbps	Mode “A” – SCPC uplink TDM, downlink TDMA
ORBCOMM	Orbital Communications Corp.	Real-time mobile two-way data and messaging services worldwide for U.S. Armed Forces, transportation, utility, oil, and gas	LEO; provides wireless e-mail, fax, and GPS; small fleet and high value asset location and alarm monitoring use	Uplink 2.4 kbps; downlink 4.8 kbps	TBS
Odyssey	Odyssey Worldwide Services	Global coverage	MEO; wireless personal communication	4.8 kbps	CDMA

**Table C-2. Public/Commercial Networks**

<b>Acronym</b>	<b>Full Name</b>	<b>Protocol Authority</b>	<b>Used By</b>	<b>Purpose</b>	<b>Security</b>	<b>User Bandwidth</b>
Internet	Internet	Internet Engineering Steering Group (IESG)	Worldwide	Voice, video, and data applications	N/A	300 bps–1.544Mbps
ATM	Asynchronous Transfer Mode	ATM Forum	Data carriers	Wide area networking	data privacy	2.4 Gbps typical
SONET/SDH	Synchronous Optical Network Synchronous Digital Hierarchy	Bellcore/CCITT; ANSI T1.105, T1.107; ANSI T1.106 and ANSI T1.117, ITU-T	United States, Europe, Japan	Transport of many digital signals with different capacities	N/A	51.48 Mbps up to 2405.376 Mbps
PSTN	Public Switched Telephone Network	ITU-14 pending	Worldwide	Provides a wide variety of voice and data services	N/A	9.6 kbps–155 Mbps

**UNCLASSIFIED**

Appendix C  
IATF Release 3.1—September 2002

**Table C-3. DoD Networks**

<b>Acronym</b>	<b>Full Name</b>	<b>Managed By</b>	<b>Used By</b>	<b>Purpose</b>	<b>Security</b>	<b>Bandwidth (for User Services)</b>	<b>Nature of User Access to Network</b>
SIPRNet	Secret Internet Protocol Router Network	DISA	U.S. DoD	Transport of classified and mission-critical data for DoD users	Network operates system high Secret; links encrypted	64 kbps–1.544 Mbps	Direct network access
ATDNet	Advanced Technology Demonstration Network	DISA	TBS	Research network with various nodes	TBS	TBS	TBS
NIPRNet	Nonclassified Internet Protocol Router Network	DISA	U.S. DoD	Transport of official data for DoD users	Network operates FOUO. Direct connected to the Internet	Up to T-3 rates	Direct network access and mobile dialin support
DISN	Defense Information System Network (Superset of SIPRNet and NIPRNet)	DISA	Global DoD community	Primarily data transport system for DII, including some voice and video	Multiple networks running system high with cryptographic separation via trunk encryptors	Currently as high as DS3 with pressure to increase capacity	Direct and remote dial-in
S-ATM (DAS-C)	DISN ATM Wide Area Network	DISA	DoD community	Secret ATM network; transport of high-speed/bandwidth mission-critical info.	Encryption	T1 up to OC-3 rates	Via agency network(s)
U-ATM (DAWN; DAS-U)	DISN ATM Wide Area Network	DISA	DoD community		N/A	T1 up to OC-3 rates	Via agency network(s)
JWICS	Joint Worldwide Intelligence Communications System	DIA	DoD community and civilian government agencies	Data and video transport; video teleconferencing at SCI level	Link encryption	56 kbps up to T1 rates	Through agency network or fixed facility

**UNCLASSIFIED**

<b>Acronym</b>	<b>Full Name</b>	<b>Managed By</b>	<b>Used By</b>	<b>Purpose</b>	<b>Security</b>	<b>Bandwidth (for User Services)</b>	<b>Nature of User Access to Network</b>
ATMAIL	TBS	TBS	TBS	TBS	TBS	TBS	TBS
DSINet	Defense Simulation Internet	TBS	TBS	TBS	TBS	TBS	TBS
DREN	Defense Research and Engineering Network	DARPA and DISA	TBS	TBS	TBS	155–622 Mbps	TBS
DRSN	Defense Red Switch Network	DISA	Global DoD community	Primarily classified voice system	Trunk encryption	TBS	Phone set
Red IDNX	Red Integrated Digital Network Exchange	USAF	DISN	Data aggregation to achieve bandwidth efficiencies	Trunk encryption	T1 and below	Integrated into transport system
Black IDNX	TBS	TBS	TBS	TBS	TBS	TBS	TBS
MILSTAR	Military Strategic Tactical Relay System	Operated by Air Force Space Command; owned by U.S. Space Command	U.S. military	Emergency action message dissemination; provides tactical survivable communication, including MSE range ext.	Encryption	75 bps–2.4 kbps; medium data rate capability 4.8 kbps–1.544 Mbps	MILSTAR terminal



**UNCLASSIFIED**

**Table C-4. Networking Technologies**

<b>Acronym</b>	<b>Full Name</b>	<b>Protocol Authority</b>	<b>Used By</b>	<b>Purpose</b>	<b>Security</b>	<b>Bandwidth (for User Services)</b>	<b>Multiple Access Method</b>
ISDN	Integrated Services Digital Network	ITU-T, Q.921, Q.931 ANSI T1.601, T1.408; and Bellcore SR 3875	Worldwide	Network browsing, transferring data, remote access	N/A	64000 bps– 1.544 Mbps	N/A
SONET/SDH	Synchronous Optical Network/ Synchronous Digital Hierarchy	Bellcore/CCITT; ANSI T1.105, ANSI T1.106 and ANSI T1.117, ITU-T	United States Europe Japan	TBS	TBS	51.48 Mbps up to 2405.376 Mbps	N/A
ATM	Asynchronous Transfer Mode	ATM Forum	Data carriers	Wide area networking; multimedia and video applications	Data privacy	2.4 Gbps typical	N/A
AMPS	Advanced Mobile Phone Service	EIA/TIA-553 U.S.	United States	Analog voice	N/A	Up to 13 kbps actual data throughput using CDMA tech.	FDMA
PCS	Personal Communications Service	TIA IS- 136A/137A/138A; J- Stds-009/010/011 ETSI PCS 1900, (PCN) DCS 1800	United States Europe	Voice and data services; paging- type services; mobile communications	Authentication and Privacy	7.95 kbps–13 kbps	TDMA FDMA
GSM	Global System for Mobile Communication	European Telecommunications Standardization Institute (ETSI)	Europe	Digital voice, data, SMS	Authentication and Privacy	9,600 bps	TDMA FDMA
DCS	Digital Cellular System	TIA IS-95; IS-136A (D-Amps)	United States	Digital voice, data	Authentication	7.9 kbps	TDMA FDMA
Frame Relay	Frame Relay	Frame Relay Forum (NNI std)-future	United States; corporations	Data communications; some voice and video	N/A	56 kbps– 1.544 Mbps	TBS

UNCLASSIFIED

Acronym	Full Name	Protocol Authority	Used By	Purpose	Security	Bandwidth (for User Services)	Multiple Access Method
SMDS	Switched Multi-megabit Data Service	Compatible with IEEE 802.6 MAN and B-ISDN	Local exchange carrier customers requiring large communications pipeline	Large data transfers; video, graphics, CAD/CAM, x-rays	N/A	1.544 Mbps–45 Mbps	TBS

**UNCLASSIFIED**

Appendix C  
IATF Release 3.1—September 2002

**This page intentionally left blank.**

# Appendix D

## System Security Administration

---

### Duties of the Security System Administrator (SSA)

The SSA must be extremely knowledgeable about the configuration of the system, the inherent security weaknesses in the use of the system components, and the security policy. To the extent that a potential threat could exploit the system, the SSAs must also remain current on vulnerability discoveries that may affect their system. The security aspects of the SSA's job are as important to the mission as the operation of the system. To that end, adequate resources must be available to allow SSAs to monitor any security policy violations and operational updates.

The SSAs must remain current in relevant technologies (e.g., operating system [OS], audit trails, configuration, and known vulnerabilities), and be provided an opportunity to remain current regarding potential attacks on their system. The System Administrator (SA) must keep the system running while the SSA ensures the Security Policy is upheld. If there is a security office for the information systems, then a SSA should be a member of that staff.

Under the direction of the Security Policy, the SSAs must operate and at times set up a secure system through use of mechanisms such as passwords (including provisions for protection, distribution, storage, length of character set, and valid duration period of password), security banners that cannot be altered by a user, session controls, lock screen, software and OS patches and updates, and account management. The SSAs must also remain current vis-à-vis potential weaknesses in the system by monitoring appropriate articles and Web sites, and they should also be on distribution for OS patches/releases and Computer Emergency Response Team (CERT) advisories. The SSA's responsibilities include conveying this information to the users, sending advisories, implementing patches, and updating procedures as needed to mitigate risk.

### Configuration Management (CM)

There should be a CM Plan that includes a CM Control Board (with a security advocate); procedures for access and changes to hardware, software, and firmware; detailed and complete system diagrams; a complete map of the system, including which ports are available; how the computers in the system communicate with each other; a discussion on who has what privileges; virus protection; Internet downloading and personal software rules; software licensing agreements and procedures; a complete list of system resources (held by the SSA) and future requirements; upgrades planned, designed, and proposed; and movement of hardware. The SSAs must remain current on the configuration and is responsible for all upgrades and changes ensuring they do not violate the Security Policy.

## **Connectivity/Network Security**

If the system is to be connected to other systems, the Security Policy must dictate the connectivity allowed. The SSAs must consider the countermeasures required to protect the information in residence or transit depending on said connectivity (e.g., Internet, dial-in, access gateways, remote access capable). When connecting to another system, it must be demonstrated that the local security policy will not be violated as a result of this connection.

## **Transmission**

The Security Policy and the Security Features Users Guide (SFUG) should address how information may be transmitted to include security mechanisms required, the allowability of e-mail, specific protocols, and attachments, and specific security mechanisms such as the need for access control, possible access to the Internet and foreign nationals, the backbone over which the information will be transmitted, and the inherent vulnerabilities associated with use of the transmission media. The SSAs are responsible for providing this service while upholding the Security Policy.

## **Auditing and Intrusion Detection**

The owner of the information must work with the SSAs to determine which events should be audited (should be determined by vulnerabilities applicable to the system). An audit trail must be maintained; an Audit Policy written as part of the Security Policy; an audit trail maintained (with Audit Reduction tools if needed), including any intrusion detection capability needed; and predefined procedures established to handle discovery of anomalous events. Audit data must be given special protection to prevent misrouting, modification, or deletion. Audit items must be updated as new vulnerabilities are discovered or when the security policy changes. The SSAs must enforce the Audit/Security Policy and monitor the audit trail taking appropriate action as defined in the Security Policy.

## **Labeling**

The Security Policy must address labeling policies including what information should be labeled, and how and when it is to be labeled (e.g., transit, storage, on the screen, disk, hard copy, and e-mail attachments). The SSAs are responsible for ensuring all users are aware of these procedures.

## **Virus Protection**

The Security Policy and SFUG should cover virus protection so that the users are familiar with the policy regarding the introduction of disks and software onto the system. The SSAs must make the SFUG available to all system users.

## Backups

A backup procedure should be in place (documented in Security Policy), including information about types of backups performed and how often; where backups are stored; how often information is inventoried; and how it will be restored; and how the SSA will verify that the system security features are intact. Physical plant needs must also be addressed: is the room fireproof, what are the physical controls, is there an uninterruptible power supply (UPS), and are relevant items backed up and secured properly. The SSAs are responsible for ensuring all users are aware of these procedures.

## Media Sanitization

The Security Policy and the SFUG should address how media are disposed of, (e.g., printed material, disks, and hard drives of sensitive and other information). The SSAs are responsible for ensuring that all users are aware of these procedures.

## System Maintenance

The organization needs to determine how and when the system will be maintained. Areas to consider are whether remote maintenance is allowed, whether it is maintained in-house or by contractor, where maintenance diagnostics will be kept, and whether they are subject to configuration management. The concept of operations (CONOPS) (and parts of the Security Policy) should also detail the procedures for equipment repair (e.g., sensitive information should first be removed) and how and when both preventive and routine maintenance are performed. The SAs are responsible for system maintenance, as described in the CONOPS.

## Physical Security

The Security Policy should document physical security requirements, including guards, alarms, locking procedures, badges, computer timeouts, exit inspection, cleaning service (escorted access and cleared access), and physical protection of the network. The SSAs are responsible for determining how the protection will be implemented (secure conduits and access to rooms).

## Security Analysis of the System

A process must be defined to periodically assess the security posture of the system being protected. An independent group will assess the system for accreditation purposes. The SSA will ensure that the system meets the criteria specified by the accreditor, will explain the system to the assessment team, and will correct any problems discovered by the assessment team.

## Suggested Documentation

- **Security Policy**—captures the security that is needed for a system supporting a particular mission and why that security is needed. It describes the mission that a system is intended to support, the mission goals, and information and resources important to the

## UNCLASSIFIED

Appendix D  
IATF Release 3.1—September 2002

mission. It identifies adversaries, their goals and motives (threat), impact statements (what is the damage if the policy is violated?), and the security policy guidelines (e.g., allowed connections). A range of security policies exists beginning at the national/departmental level going down through individual unit policies where refinement is made for local conditions.

- **CONOPS**—describes how the system will work, including connectivity and how information flows through the systems and to remote sites.
- **System Architecture Description**—describes in technical detail how the hardware and software provide the requisite security services.
- **System Configuration Management**—describes configuration data and the configuration management process.
- **Security Features Users Guide**—describes the security features and regulations for the system users.
- **Other Guides**—include a number of aides for system and security administration that were developed under the Secret and Below Interoperability (SABI) process and efforts to establish requirements for certification of security administrators that were completed recently.

The SSAs will need to be updated regularly; tailored information exists regarding the vulnerabilities and suspected or observed attacks on the network components, including internetwork infrastructure. This information would include items such as CERT advisories, vendor bug fixes, and articles about computer security bulletin boards.

## References

### Additional Information for SSAs

1. NCSC I942-TR-003 Version 1, Information System Security Policy Guidelines, July, 1994.
2. NCSC-TG-026, Version 1, Security Features Users Guide for Trusted Systems, September, 1991.
3. Frisch, Aeleen, Essential System Administration, 2<sup>nd</sup> edition, O'Reilly and Assoc., Sept, 1995, 101 Morris St, Sebastopol, CA 95472, (800) 998-9938.
4. Frisch, Aeleen, Essential Windows NT System Administration, O'Reilly and Assoc., Nov, 1997, 101 Morris St, Sebastopol, CA 95472, (800) 998-9938.
5. Garfinkel, Simson and Spafford, Gene, Practical UNIX and Internet Security, 2<sup>nd</sup> edition, O'Reilly and Assoc, July, 1991, 101 Morris St, Sebastopol, CA 95472, (800) 998-9938[6]  
Garfinkel, Simson and Spafford, Gene, Web Security and Commerce, June, 1997, O'Reilly and Assoc., 101 Morris St, Sebastopol, CA 95472, (800) 998-9938.
6. Nemeth, Eui, Snyder, Gart, Seebass, Scott, and Hein, Trent, UNIX System Administration Handbook, 2<sup>nd</sup> edition, Jan, 1995, Prentice Hall.
7. Russell, Deborah and Gangemi, G.T., Sr, Computer Security Basics, July, 1991, O'Reilly and Assoc., 101 Morris St, Sebastopol, CA 95472, (800) 998-9938.
8. Sutton, Steve, Windows NT Security Guide, Jan, 1997, Addison Wesley.



**UNCLASSIFIED**

Appendix D  
IATF Release 3.1—September 2002

**This page intentionally left blank.**

# Appendix E

## Office of the Secretary of Defense

### Information Assurance Policy

### Robustness Levels

---

According to the Office of the Secretary of Defense (OSD) Global Information Grid (GIG) policy, technical Information Assurance (IA) solutions in the defense-in-depth strategy will be at one of three defined levels of robustness: high, medium, or basic, corresponding to the level of concern assigned to the system. The three levels of technical robustness solutions identified in the OSD GIG Policy are described in the following subparagraphs.

- High robustness security services and mechanisms provide the most stringent protection and rigorous security countermeasures. High robustness solutions require all of the following:
  - National Security Agency (NSA)-certified Type 1 cryptography (algorithms and implementation) for encryption, key exchange, digital signature, and hash.
  - NSA Type 1 cryptographically authenticated access control (e.g., digital signature, public key cryptography based, and challenge/response identification and authentication).
  - Key management:
    - For symmetric key, NSA-approved key management (production, control, and distribution).
    - For asymmetric key, Class 5 Public Key Infrastructure (PKI) certificates and hardware security tokens that protect the user's private key and crypto-algorithm implementation.
  - High-assurance security design, such as specified by NSA or the International Common Criteria (CC) at a minimum an Evaluated Assurance Level (EAL) greater than 4.
  - Products evaluated and certified by NSA.
- Medium robustness security services and mechanisms provide for additional safeguards above the Department of Defense minimum. Medium robustness solutions require, at a minimum, all of the following:
  - National Institute of Standards and Technology (NIST) Federal Information Processing Standard (FIPS) validated cryptography (algorithms and implementation) for encryption, key exchange, digital signature, and hash (see algorithms at Table 5-4).
  - NIST cryptographically authenticated access control (e.g., digital signature, public key cryptography based, and challenge/response identification and authentication).
  - Key management:

## UNCLASSIFIED

Appendix E  
IATF Release 3.1—September 2002

- For symmetric key, NSA-approved key management (production, control, and distribution).
  - For asymmetric key, Class 4 PKI certificates and hardware security tokens that protect the user's private key.
  - Good assurance security design, such as specified in CC as EAL3 or greater.
  - Solutions evaluated and validated under the Common Criteria Evaluation validation scheme or NSA.
- Basic robustness solutions are equivalent to good commercial practice. Basic robustness require, at a minimum, all of the following:
    - NIST FIPS validated cryptography (algorithms and implementation) for encryption, key exchange, digital signature, and hash (see algorithms at Table 5-4).
    - Authenticated access control (e.g., digital signature, public key cryptography based, challenge/response identification and authentication, or preplaced keying material).
    - Key management:
      - For symmetric key, NIST-approved key management (production, control and distribution).
      - For asymmetric key, Class 3 PKI certificates or preplace keying material. See reference (p) for policy on migration to Class 4 certificates and software tokens (private keys held in software on the user's workstation).
    - CC EAL 1 or greater assurance.
    - Solutions evaluated and validated under the National Information Assurance Partnership (NIAP) CC Evaluation Validation Scheme or NSA.

The OSD GIG Policy indicates that the robustness of a network solution must be considered in the context of defense-in-depth and the threat environment in which the system operates. For instance, a system operating on a protected backbone between secure enclaves may not require additional mechanisms for authentication and access control. In addition, if community of interest separation is provided through encryption, it will require less robust solutions.

# Appendix F

## Executive Summaries

---

This IATF section is a repository for Executive Summaries. An Executive Summary captures the essence of a user's need in clear, concise statements. The security approach outlined in the Executive Summary points to supporting documentation such as protection profiles.

The Target Environment section describes the purpose and scope of the executive summary and associated protection profiles. It includes the following:

- Title: NSA Security Guidance for "Descriptive Name"
- Target Environment
- Potential Attacks
- Security Policy and Objectives
- Recommended Approach
- Security Functions
- Assurance Requirements
- Interoperability Requirements
- Supporting Infrastructure
- Administrative Information

iatf\_f\_1001

**Figure F-1. Executive Summary Outline**

- Which kind of Protection Profile (PP) is this (e.g., defense-in-depth, technology goal, customer-specific)?
- Describe the types of user organizations in the scope of this document.
- What does the user organization want the system to do?
  - What is the problem the system is intending to solve?
- Summarize the system environment:
  - Where does the system operate?
  - How will the system be used?
  - Provide a diagram of the system context.

The Potential Attacks section includes the following:

- What are the information system attacks/events for which protection is needed?
  - How can an adversary harm the user organization's mission by attacking the system?
  - What nonmalicious events (e.g., flood, user error) can harm the user organization's mission through information system effects?
- Attacks should be relevant to the technology under consideration, but should not assume implementation details.

The Security Policy and Objectives section includes the following:

- What is the organization policy or other rules that the system must meet or support?
  - Provide the technology-unique context for the policy and objectives (e.g., defend-the-enclave, tunneling).

## UNCLASSIFIED

Appendix F

IATF Release 3.1—September 2002

- Referencing Global Information Grid (GIG) policy, describe the robustness category (basic, medium, or high) and any recommended deviations from the policy.
- Describe the level of threat and value of information.
- What are the information domains of interest?
  - An information domain is defined by a *type of information* and the *set of users* with *specific privileges* for access to that information.
- What security objectives must the system meet to protect against the information system attacks?

The Recommended Approach section includes the following:

- What is the conceptual architecture for the system?
- Which security functions are allocated to the technology under consideration?
- What are the dependencies on security functions of other system components?
- Diagram of the system should be included.

The Security Functions Section includes the following.

- What are the security functional requirements for the system?
  - Include strength of mechanisms and cryptographic algorithm suite.
- What security services must the system perform for each information domain (e.g., confidentiality, integrity, and availability)?
- Describe compliance with GIG policy for placement of security functions.

The Assurance Requirements section includes the following:

- Indicate the required Evaluated Assurance Level (EAL) as defined in the Common Criteria.
- Describe additional assurance requirements or (e.g., Federal Information Processing Standard [FIPS] 140-1 verification).
- Describe compliance with GIG policy for assurance.

Interoperability Requirements section includes the following:

- What are the interoperability requirements that the system components must meet? (e.g., Transmission Control Protocol [TCP]/Internet Protocol [IP], security protocols).

The Supporting Infrastructure section includes the following:

- What support does the system require from key management infrastructure (e.g., certificate class and version)?

- What support does the system require from network security management infrastructure (e.g., audit analysis)?

The Administrative Information section of each Executive Summary must include the following:

- List of PPs within the scope of the Executive Summary.
- Date and version number.
- Author block.
- Approval block.

The National Security Agency (NSA) will provide additional configuration management guidance.

**UNCLASSIFIED**

Appendix F  
IATF Release 3.1—September 2002

**This page intentionally left blank.**

# Appendix G

## Protection Profiles

A protection profile is an implementation-independent specification of information assurance security requirements. Protection profiles are a complete combination of security objectives, security-related functional requirements, information assurance requirements, assumptions, and rationale. Protection profiles are written in accordance with the Common Criteria (CC) for Information Technology Security Evaluation, International Standard ISO/OEC 15408-1. The use of protection profiles to define information assurance requirements is part of the National Information Assurance Partnership (NIAP) program.

The protection profiles are posted on the Information Assurance Technical Framework (IATF) Web site, [http://www.iatf.net/protection\\_profiles/](http://www.iatf.net/protection_profiles/). They are being developed to support acquisition of information assurance-related products needed by the U.S. Government. As additional protection profiles become available, they will also be posted on the IATF Web site. In addition, any updates of current protection profiles—as they move toward NIAP validation for example—will be posted on the site. The protection profiles are posted on the web site in Defense-in-Depth categories. Table G.1 contains an example of the table on the web site that lists the protection profiles. The list is updated as new profiles are added or the status of the profile changes (e.g. profile become NIAP validated).

**Table G.1. Example list of Protection Profiles on the IATF Web Site**

Defend the Network and Infrastructure	Defending the Enclave Boundary	Defending the Computing Environment	Supporting Infrastructures	
			KMI/PKI	Detect and Respond
Switches and Routers	Firewalls	Operating Systems	Certificate Management	IDS
	VPNs	Biometrics	Key Recovery	
	Peripheral Sharing Switch	Single Level Web	Class 4 PKI Directory	
	Multiple Domain Solutions	Tokens		
	Remote Access	Mobile Code		
	Mobile Code	Secure Messaging		
	Guards			



**UNCLASSIFIED**

Appendix G  
IATF Release 3.1—September 2002

**This page intentionally left blank.**

# Appendix H

## Protection Needs Elicitation

---

### Table of Contents

List of Figures .....	iii
List of Tables.....	iii
H.1 INTRODUCTION .....	H-1
H.1.1 Purpose.....	H-1
H.1.2 PNE and the INFOSEC Business .....	H-4
H.1.3 PNE, ISSE, and SE Process .....	H-5
H.1.4 PNE and Common Criteria.....	H-6
H.1.5 PNE and DITSCAP .....	H-7
H.1.6 PNE and Risk Management.....	H-8
H.2 OVERVIEW.....	H-9
H.2.1 PNE Practitioner Characteristics .....	H-9
H.2.2 Acronyms.....	H-10
H.2.3 PNE/ISSE Documents .....	H-10
H.2.4 Seven Procedures.....	H-11
H.2.5 Approaching the Customer .....	H-11
H.2.6 Acquiring the IMM.....	H-11
H.2.7 The Least-Privilege IMM .....	H-11
H.2.8 Threat Analysis .....	H-11
H.2.9 Customer Priorities .....	H-12
H.2.10 Preparing the IPP .....	H-12
H.2.11 Customer Buy-In.....	H-12
H.3 APPROACHING THE CUSTOMER.....	H-12
H.3.1 Making Initial Contacts .....	H-13
H.3.2 Learning the Business and Mission .....	H-14
H.3.3 Developing Contacts.....	H-14
H.3.4 Selling the Value of PNE.....	H-15
H.3.5 PNE Project Planning .....	H-16
H.3.6 Setting Project Roles and Responsibilities .....	H-17
H.4 ACQUIRING THE IMM.....	H-17
H.4.1 Information Management and Models.....	H-18
H.4.2 What Has the Customer Already Done.....	H-19
H.4.3 Description of IMM.....	H-20

UNCLASSIFIED

Appendix H  
IATF Release 3.1—September 2002

H.4.4 Other Models ..... H-21  
H.4.5 Why IMM Is Important..... H-25  
H.5 THE LEAST-PRIVILEGE IMM..... H-25  
H.5.1 Least-Privilege Concept..... H-26  
H.5.2 Consolidation..... H-26  
H.5.3 Information Domains..... H-27  
H.5.4 Revised IMM..... H-28  
H.6 THREAT ANALYSIS ..... H-28  
H.6.1 Identifying Harm to Information ..... H-29  
H.6.2 Identifying Potentially Harmful Events..... H-30  
H.6.3 Combining HTI and PHE to Estimate Information Threats ..... H-31  
H.7 CUSTOMER PRIORITIES ..... H-34  
H.7.1 Presenting the Threat Analysis ..... H-34  
H.7.2 Obtaining the Customer’s View ..... H-35  
H.7.3 Managing Reactions ..... H-35  
H.7.4 Setting Priorities ..... H-36  
H.7.5 Achieving Consensus..... H-36  
H.8 PREPARING THE IPP..... H-36  
H.8.1 Explain the IPP Purpose and Type of IPP ..... H-37  
H.8.2 Identify Existing Policies, Regulations, and Procedures..... H-37  
H.8.3 Establish Roles and Responsibilities ..... H-38  
H.8.4 Identify Decision Makers..... H-39  
H.8.5 Define C&A Procedures ..... H-39  
H.8.6 Identify Security Service Requirements ..... H-39  
H.8.7 Document Results..... H-42  
H.9 CUSTOMER BUY-IN ..... H-42  
H.9.1 Explain Ownership (Again)..... H-43  
H.9.2 Explain the Need for High-Level Endorsement ..... H-43  
H.9.3 Explain the Need for Maintenance ..... H-43  
H.9.4 Explain the Need for Necessary Resources ..... H-43  
H.10 SUMMARY ..... H-44  
PNE GLOSSARY AND ACRONYM LIST ..... H-45  
REFERENCES..... H-47  
PNE ANNEX A: IMM EXAMPLE  
PNE ANNEX B: CORPORATE IPP  
PNE ANNEX C: DIVISION IPP

**List of Figures**

Figure H-1.	Requirements Hierarchy.....	H-2
Figure H-2.	Requirements—Need Versus Solution.....	H-4
Figure H-3.	PNE Within the INFOSEC Business .....	H-5
Figure H-4.	SE (and ISSE) Process .....	H-6
Figure H-5.	Protection Profile.....	H-7
Figure H-6.	DITSCAP Subprocesses of Phase 1—Definition .....	H-8
Figure H-7.	Risk Management.....	H-9
Figure H-8.	Seven Procedures .....	H-11
Figure H-9.	Information Management Model .....	H-19
Figure H-10.	IDEF Model Example .....	H-22
Figure H-11.	IDEF With Buffers and Release.....	H-22
Figure H-12.	IDEF Modified .....	H-23
Figure H-13.	Structured Analysis Model.....	H-24
Figure H-14.	Types of Harm to Information .....	H-29
Figure H-15.	Sources of Potentially Harmful Events .....	H-30
Figure H-16.	Adversaries.....	H-30
Figure H-17.	Information Threat .....	H-32
Figure H-18.	Map Type of Harm to Security Service .....	H-41

**List of Tables**

Table H-1.	Requirements—Need versus Solution .....	H-3
Table H-2.	Simple Example of an IMM.....	H-20
Table H-3.	Table Model of IMM.....	H-24
Table H-4.	Least-Privilege Example .....	H-26
Table H-5.	Categories Before Consolidation .....	H-27
Table H-6.	Categories After Consolidation.....	H-27
Table H-7.	Information Domain Example.....	H-27
Table H-8.	PHE and HTI Measures.....	H-32
Table H-9.	Information Threat Data.....	H-33
Table H-10.	Information Threat Combination Matrix.....	H-33
Table H-11.	Information Threat Table (ITT) .....	H-34
Table H-12.	Information Threat Table .....	H-40
Table H-13.	Information Threat Data.....	H-40
Table H-14.	Map ‘Information Threat’ to ‘Strength’ .....	H-41
Table H-15.	Data for Information Protection Requirements.....	H-42

**UNCLASSIFIED**

Appendix H  
IATF Release 3.1—September 2002

**This page intentionally left blank**

# Appendix H

## Protection Needs Elicitation

---

### H.1 Introduction

Information systems security engineering (ISSE) is defined in Chapter 3 as a sub-process of systems engineering (SE). The basic activities of SE are to—

- Discover Needs.
- Define System Requirements.
- Design System Architecture.
- Develop Detailed Design.
- Implement System.
- Assess Effectiveness.

The ISSE process is involved in each of these basic activities. This document describes Protection Needs Elicitation (PNE), that part of Discover Needs in which information protection needs are determined or elicited from customers.

ISSE practitioners must understand the merits of ISSE so they can educate customers. The ISSE practitioner, like the systems engineer, must achieve a balance between satisfying best practice and the desires of customers to advance to an expedient implementation. The goal of the ISSE activities process covered in this appendix is to describe ISSE best practice.

#### H.1.1 Purpose

This section defines the protection needs elicitation activity and directs the PNE practitioner to—

- Help customers model their information management.
- Help customers to define an information threat. (Typically, customers know more about their threats than the systems security engineer does.)
- Instruct the customer to document perceived threats and responses to them.
- Help customers to prioritize their protection needs.
- Prepare information protection policies that security architects can use.
- Achieve customer buy-in. (If the PNE practitioner applies the following principles, the resulting analysis will be understandable, acceptable, and supported by the customer. This buy-in is critical to any program.)

Although there are many activities that support the business or mission of an organization, such as manufacturing or the use of weapon systems, information management is the chief concern

here. Before the information system solution is designed and implemented, requirements should be thoroughly analyzed and prioritized. This activity not only saves the customers substantial cost and time, it also produces better operational results. A similar information-requirements analysis is also valuable relative to an existing system—before installing upgrades, and before analyzing the risk posture of the system even when no changes are planned.

Information management always carries with it the risk of unwanted disclosure, modification, or loss. Customers realize the importance of their information but usually need help in discovering their protection needs and priorities. This appendix defines a method for eliciting those customer protection needs.

The word “needs” here is interchangeable with “requirements.” Many meanings are associated with “requirements.” Some rank desires, needs, and requirements alongside nice-to-have, very useful, and essential. Rather than making distinctions, it is important to recognize and prioritize needs and requirements and especially to distinguish between “good” and “not good” requirements.

A layered requirements hierarchy may be envisioned (see Figure H-1) that asserts a layer (shown to the left in Figure H-1) that imposes requirements on the next lower layer. What are called “requirements” may help identify which layers are affected.

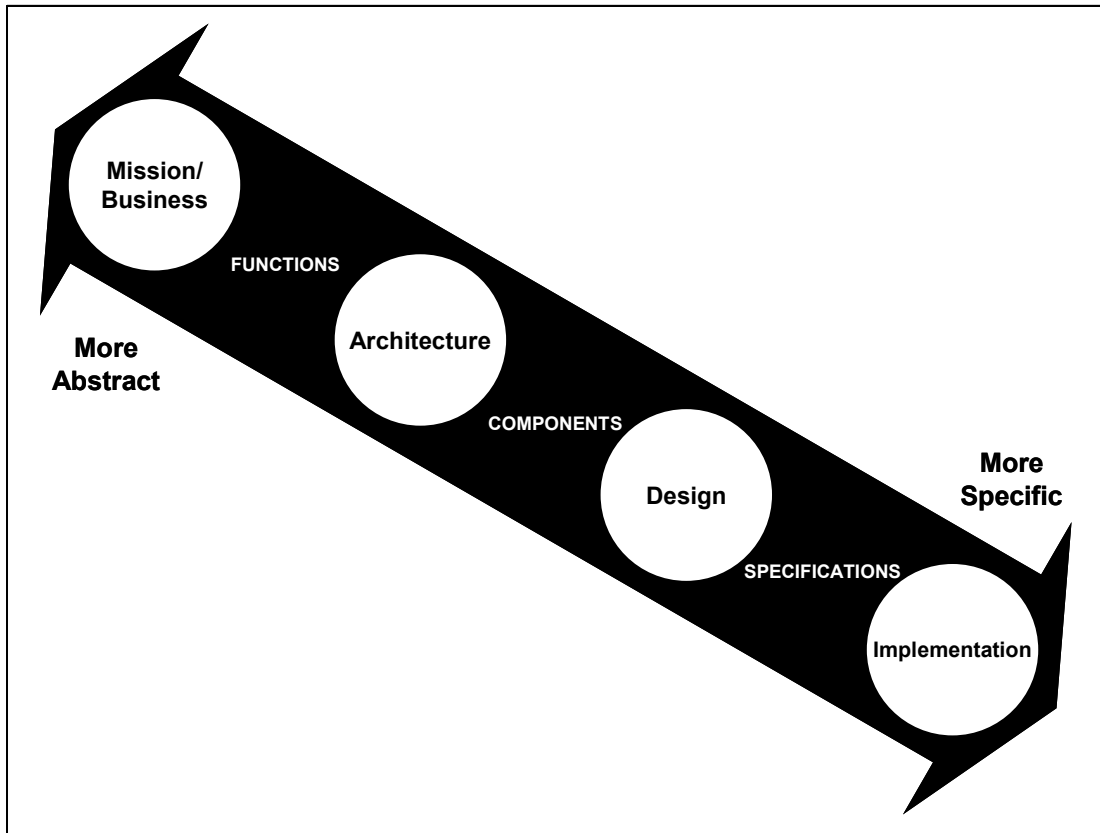

iatf\_h\_1\_0084

Figure H-1. Requirements Hierarchy

What is considered a good requirement depends on where one is in the hierarchy. What remains consistent is that requirements become more specific as one moves downward in the hierarchy and more abstract as one moves upward. A good requirement does not jump elements of the layers. It gives practitioners the flexibility to exercise their skills to produce better results.

Table H-1 illustrates a jump from a protection need to a specific solution. A practitioner who uses a solution-based approach (sometimes hard to avoid) should not spend much time with architecture or component design. A better approach would be to seek the need underlying the design limitation and to obtain customer concurrence.

**Table H-1. Requirements—Need versus Solution**

Basis of Requirement	Value of Approach	Typical Criteria			Example
Need	Good	Need	What	Abstract	I need protection from disclosure of my information.
Solution-based	Not good	Solution	How	Specific	I need KG-175 TACLANE COMSEC devices.

Although the specifications requirements (from design to implementation) may ultimately include a crypto-device such as a KG-175, the conceptual requirement (from architecture to design) is transmission confidentiality. The corresponding functional requirement (from mission to architecture) is a need to protect the information from disclosure while it is being transferred between any two entities.

Figure H-2 illustrates the relationship between the PNE portion of ISSE and SE. Assuming that business or mission success depends on successful information management, information management functions (models) form the basis for information system requirements that are consistent with the organization's information management policy. A system architecture can be proposed to meet the information system requirements. ISSE is indicated in Figure H-2 by the four shaded areas. PNE is indicated by the darker shading.

Adversaries can threaten the success of the business or mission. Threats may be directed at the information management functions and also at people, manufacturing processes, or product management. The response to the possibility of threats to information is an Information Protection Policy (IPP) that directs and prioritizes the response to those threats. Through system definition, some of the elements of the IPP are allocated to the target system to become the information system security requirements. Those requirements lead to the design of a security architecture.

The system architecture provides a baseline definition for threats to the system or specific attacks on it that will need to be countered by the security architecture. This appendix is concerned with the information management functions, information threats, and the IPP part of the ISSE process shown in Figure H-2.



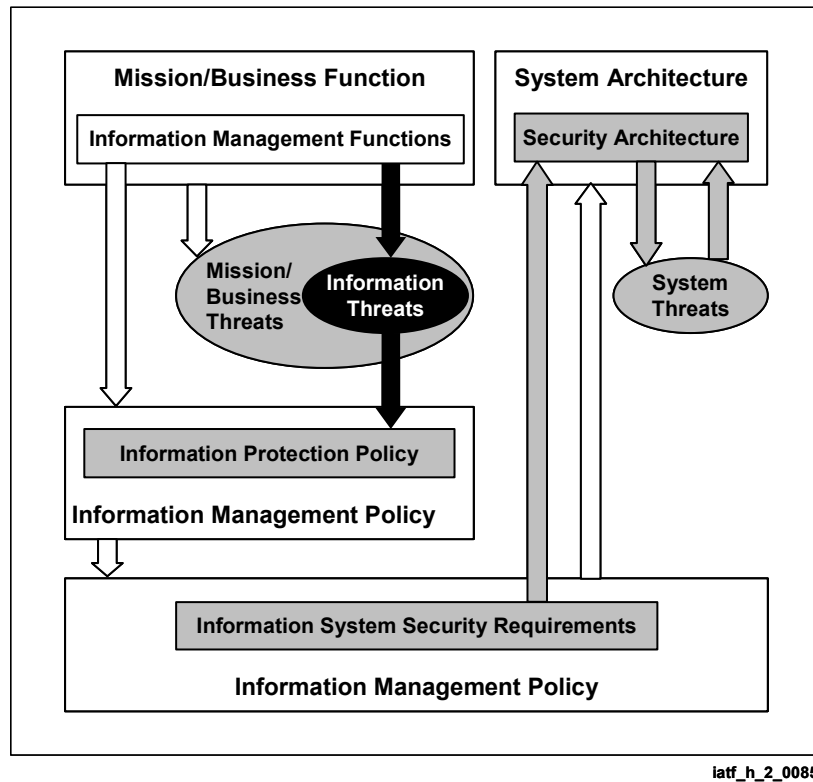

**Figure H-2. Requirements—Need Versus Solution**

PNE supports many disciplines, programs, processes, and activities. For example—

- The Information Systems Security (INFOSEC) business.
- The SE process, which includes the ISSE process.
- The evaluation of security products, including those in which Common Criteria language is used.
- The Department of Defense (DoD) Information Technology Security Certification and Accreditation Process (DITSCAP).
- Risk management.

## H.1.2 PNE and the INFOSEC Business

ISSE combines security disciplines, technology, and mechanisms (see Figure H-3) and applies them to satisfy the protection needs of the customer. The result is an information system that incorporates the security architecture and mechanisms that best meet protection needs within the cost, performance, and schedule allowed by the customer. PNE is the ISSE customer interface activity. SE engages the customer for the other requirements.

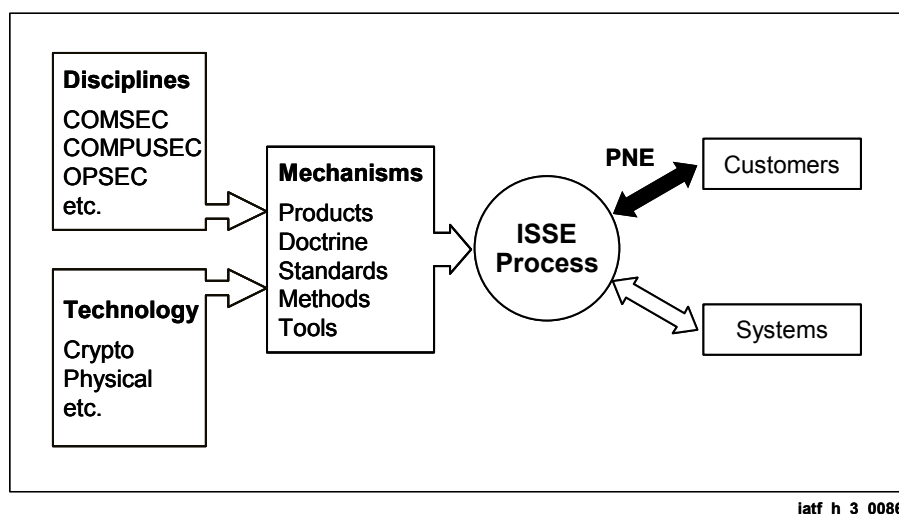

Figure H-3. PNE Within the INFOSEC Business

## H.1.3 PNE, ISSE, and SE Process

Because ISSE is a specialty within SE, it follows the methods of that discipline. ISSE usually works in an environment in which the customers may have their own methods or processes. PNE is part of all ISSE activities and probably provides the biggest potential cost-saving opportunity within the ISSE process. The security and nonsecurity benefits of PNE are discussed in Section H.3.4. Figure H-4 depicts the six activities of the SE and ISSE process that draw from and respond to users and customers:

- Discover Needs.
- Define System Requirements.
- Design System Architecture.
- Develop Detailed Design.
- Implement System.
- Assess Effectiveness.

In the Discover Needs activity, ISSE—

- Analyzes mission and business.
- Analyzes information management.
- Elicits data on mission capability needs, including information threatened and information protection needs (PNE).
- Achieves stakeholder consensus on those needs, including information protection needs.

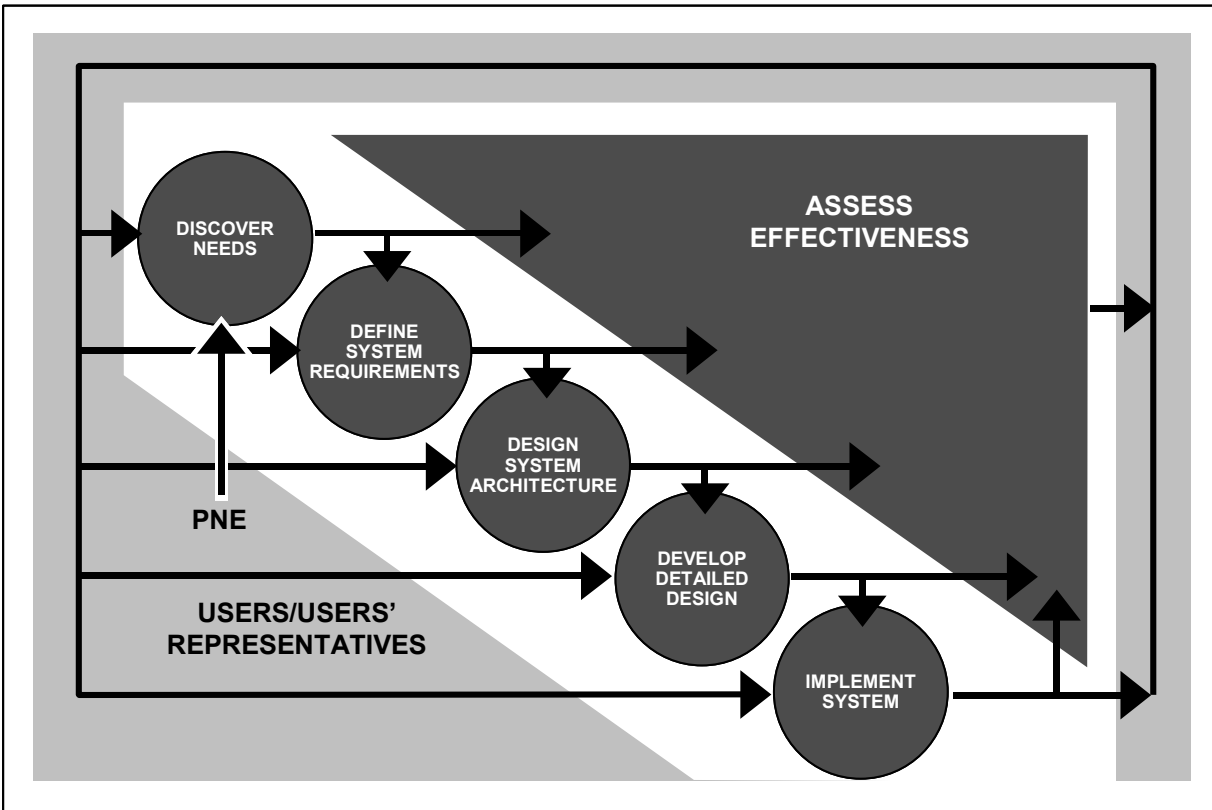

**Figure H-4. SE (and ISSE) Process**

Clearly, PNE performs Discover Needs activities. The Discover Needs activity does in fact elicit information protection needs on the basis of what harm there would be to the mission or business if information were disclosed, modified, unavailable, or lost.

PNE is an integral part of Discover Needs. The mission and business needs include protection needs. But the scope of PNE is limited to information management. PNE is not engaged with either architecture or implementation.

Finally, there is a valid rationale for using the PNE “achieving user/customer consensus” function in the ISSE Assess Effectiveness activity.

## H.1.4 PNE and Common Criteria

The Common Criteria have evolved from international computer security product evaluation criteria. The Common Criteria language is a selectable set of statements defined as security functions and an independent set of assurance levels that describe function success. Because use of Common Criteria is still primarily oriented toward security products, the relationship between PNE and Common Criteria is complicated. PNE provides the information protection portion of the mission or business description. That information may be applied to creating two types of

Common Criteria documents, a protection profile and a security target. Because both documents refer to a security product or system called a target of evaluation (TOE), they cannot be completed until a system or product is designed. PNE provides Common Criteria information for—

- Creating a description (a Protection Profile) of an organization’s protection needs for the TOE, using mostly pre-specified functions and assurance levels—the Common Criteria language. The Protection Profile provides a statement, independent of implementation, of the functions and assurances the organization needs.
- Creating a description (the Security Target) of a solution after evaluating how a particular security solution or category of solutions satisfies a particular TOE’s Protection Profile. The Security Target, which is directly related to a TOE, explains how the TOE meets function and assurance needs.

Figure H-5 shows the content of a Protection Profile. The PNE process provides the security objectives. In reality, the TOE’s security functions and assurance level can be derived only from an analysis of the organization’s requirements and threats, from which the security objectives are drawn. The PNE security objectives are a detailed set of security services and strengths that are prioritized by the customer. They must be translated into the language of the Common Criteria, which is syntactically rigid but allows new functions to be created in the form of the language.

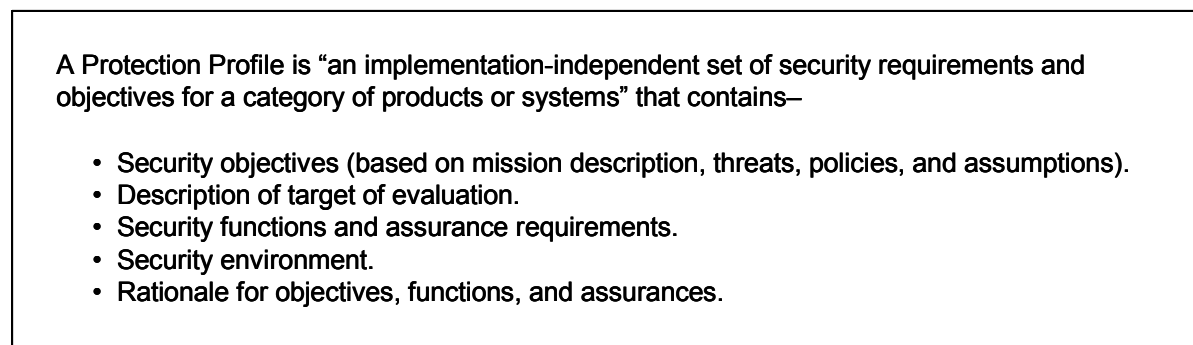

iatf\_app\_h\_5\_h005

**Figure H-5. Protection Profile**

## **H.1.5 PNE and DITSCAP**

DITSCAP, the DoD’s standard process for certification and accreditation (C&A) of information technology (IT), provides an excellent list of things to be discovered and documented to guide the C&A process, but it provides no clues as to how to acquire the information. This appendix does. For DITSCAP, it is necessary to prepare and continually update a document called the System Security Authorization Agreement (SSAA). The SSAA serves as a control document for the security of the IT system from “womb to tomb” for both full and contingent accreditations. In the early phases of DITSCAP, the SSAA documents the requirements, including a form of a security policy. The DITSCAP has four phases—

- Phase 1—Definition.
- Phase 2—Verification.
- Phase 3—Validation.
- Phase 4—Post-Accreditation.

PNE satisfies some of Phase 1 of DITSCAP. The subprocesses of Phase 1 that match PNE are boldface in Figure H-6.

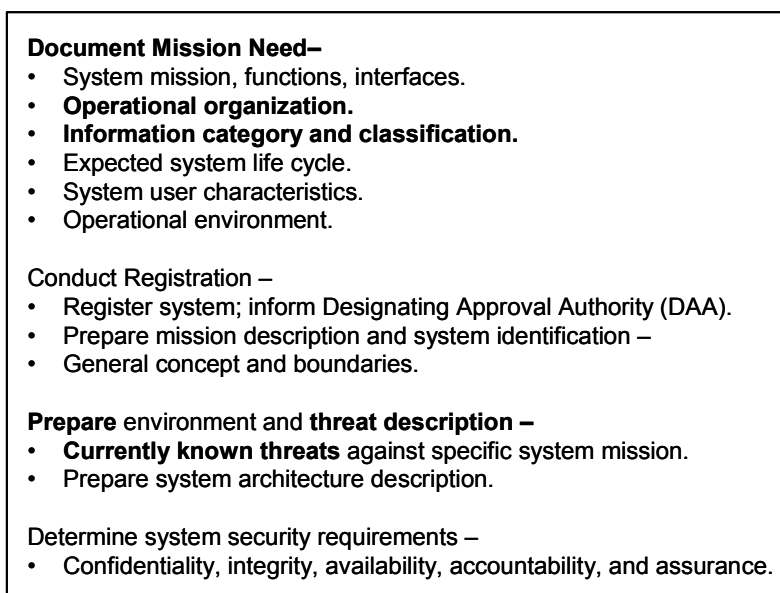

latf\_app\_h\_6\_h006

Figure H-6. DITSCAP Subprocesses of Phase 1—Definition

## H.1.6 PNE and Risk Management

Risk management programs require documentation of exactly the same mission and security needs as ISSE (see Figure H-7). The only difference is that the emphasis is assessing risks of and improving existing systems rather than designing new systems.

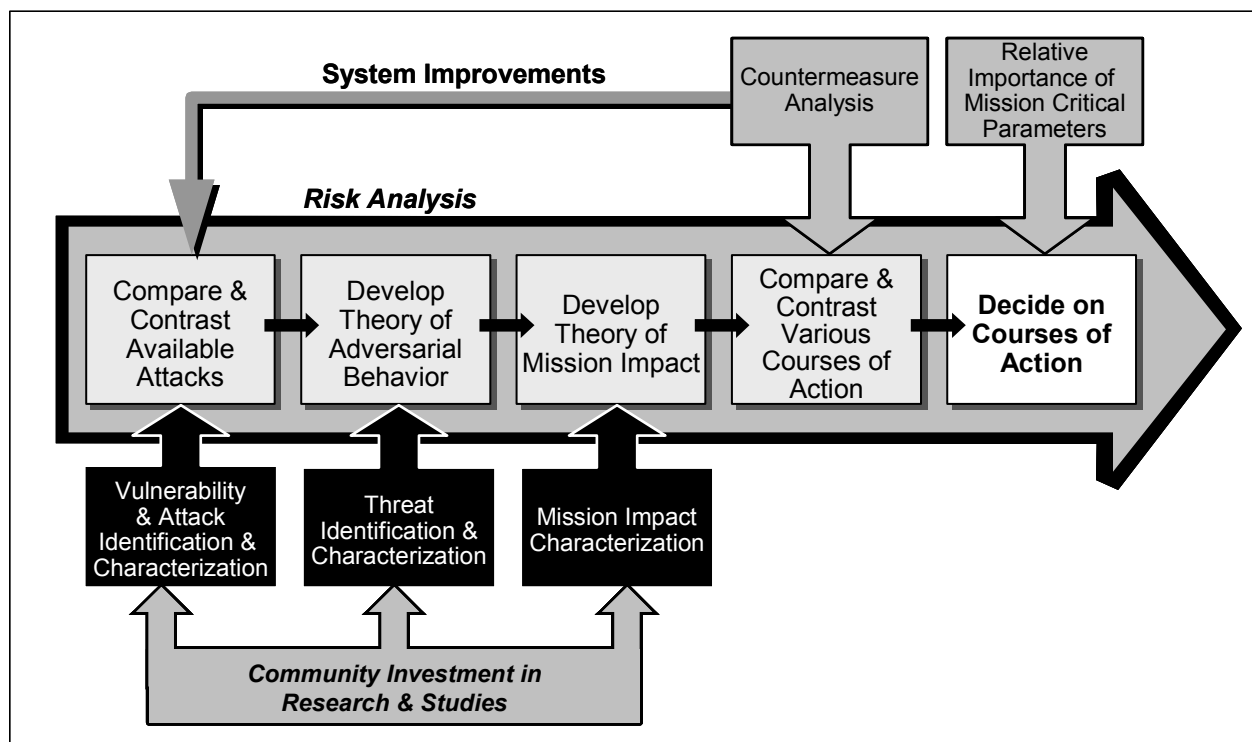

iatf\_app\_h\_7\_0144

Figure H-7. Risk Management

## H.2 Overview

This section summarizes the seven major PNE procedures, but begins by addressing the following three items—

- The characteristics expected of the PNE practitioner.
- Important acronyms.
- The types of documents that should result when the PNE process is completed.

### H.2.1 PNE Practitioner Characteristics

The ideal PNE practitioner is a systems engineer or systems analyst who has—

- Familiarity with the business and mission area.
- Good communications skills.
- An information security background.
- Program management experience.

The most important asset for the PNE practitioner is the ability to approach problems with a systems approach to problem solving. The ISSE engineer can think abstractly and can conduct analysis on the basis of intuiting eventual results. Engineering training often forces a degree of

detail and thoroughness that encourages engineers to use a bottom-up approach. This section emphasizes a top-down approach for the PNE practitioner as the preferred approach. The systems analyst can play a role identical to, or share responsibilities with, an information systems security engineer in the PNE process.

A general knowledge of the business or mission area is not essential for the PNE practitioner, but it does shorten the learning curve and facilitates communicating with the customer. In addition, program management experience for systems engineers, adds value to an SE team.

## H.2.2 Acronyms

The acronyms that have special relevance here are—

- **IMM**—Information Management Model.
- **IPP**—Information Protection Policy.
- **ISSE**—Information Security Systems Engineering (or Engineer).

## H.2.3 PNE/ISSE Documents

The following documentation could result from the PNE process.

- **Project Plan/Task Definition**—prepared by the information systems security engineers and briefed to the customer.
- **Customer Documentation**—although optional, customer documentation further supports the project plan and task definition with details of what is expected.
- **IMM**—an initial model of the eventual information system, which embodies the important concept of least privilege.
- **IPP**—the latest documented set of protection needs in the form of a policy, which represents the final result of the PNE. The policy contains a threat analysis describing potentially harmful events and their effects. The IPP also contains a prioritized list of needed security services.

Defining the information protection that is required can be very precise. Is the amount of detail produced by PNE useful and necessary? Indeed it can be. When the ISSE process arrives at risk analysis, a detailed IPP will be a sound basis for comparing what was required with what was accomplished. A disadvantage, though, is that details may be ignored during security-architecture and implementation, because the designers may take shortcuts and simplify the system for good, practical reasons. In each situation the information systems security engineer and the customer determine how much detail is needed. Further, both the customer and the accreditor should fully understand and accept the degree of detail.

## H.2.4 Seven Procedures

PNE requires the application of seven procedures (see Figure H-8).

## H.2.5 Approaching the Customer

After the initial contact, the PNE practitioner needs to understand—at more than surface-level—the customer’s business or mission. This understanding helps to build customer confidence, which is important in promoting the value of PNE to the customer’s security management program. At this stage, the practitioner presents the customer with a budget and an analysis plan that defines specific roles and responsibilities.

## H.2.6 Acquiring the IMM

A model is a representation of concepts with the purpose of reducing ambiguity. The ISSE engineers eventually become familiar with various customer models, but the models will all have common information elements that are useful to PNE. If the customer has not constructed an IMM, the information systems security engineer will need to develop one. The importance of information management is apparent from Figure H-2. Modeling at this stage, which visually presents how information is managed, includes incorporating the customer’s models into a comprehensive IMM.

## H.2.7 The Least-Privilege IMM

Information access is an IMM issue. The modeling of information management should naturally try to define only those people or jobs that are necessary to accomplish mission or business functions. Often, however, there is a need to review the results to redefine “necessary.” A least-privilege revision of the IMM helps to eliminate unnecessary access to information and provides a better baseline for threat analysis.

## H.2.8 Threat Analysis

“Threat analysis” means different things to different people. In PNE, threat analysis takes into account the information, information management, the definition of adversaries, adversary motivation, non-malicious harmful events, and the effects of harmful events. It is important to note that during the PNE phase of ISSE there is no definition of the system and hence no possible notion of vulnerabilities.

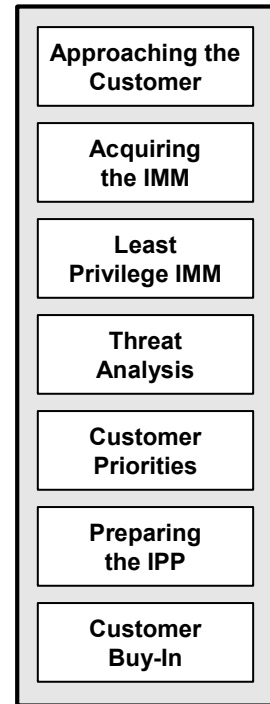

iatf\_h\_8\_0090

**Figure H-8. Seven Procedures**



## H.2.9 Customer Priorities

Providing the best information to help the customer recognize threats will result in the most successful threat analysis. The threat analysis should be prioritized and at a level of detail that the customer can absorb. Reactions to the threat analysis within the customer's organization may be diverse, which will require resolution.

## H.2.10 Preparing the IPP

The IPP is a policy document (note that “policy” has as many definitions as “threat”). The IPP lists the requirements for any solution to protect the managed information. It is a vehicle for resolving issues by coordination (through publishing, reviewing, and commenting and modification). The intent of PNE is to produce a very detailed IPP, covering all types of information, user privileges, and required security services. The IPP is useful to the security architect, who is one of the principal targets for its application.

## H.2.11 Customer Buy-In

Achieving customer support of the agreement to maintain and enforce the IPP, including the application of the resources and agents responsible for its execution, completes the PNE procedure. Customer support of the agreement is crucial for—

- Definition of the system solution.
- Development of a security architecture consistent with the IPP.
- Development of a system consistent with the IPP and the security architecture.

The following sections provide more detail about the seven PNE procedures and offer ISSE strategies for planning a PNE project.

## H.3 Approaching the Customer

Probably the most critical step in any ISSE project is Approaching the Customer. Some believe that the information systems security engineer should not talk with the customer but only with the customer's technical representatives. However, if all the information systems security engineer knows about the project is what the system engineers convey, the project will be severely handicapped. The information systems security engineer must be grounded in the customer's needs so it can try to satisfy them. The engineers must explain suggested plans and services and obtain the customer's concurrence. Obviously, this activity is marketing and



iatf\_h\_8\_0090

contracting. It is critical that the PNE practitioner be professionally prepared by—

- Knowing as much as possible about the customer.
- Leveraging initial contacts.
- Presenting the benefits of proposed services to decision makers concisely.

Whether seeking a contract or undertaking tasks, the engineers and systems analysts must clarify their roles and responsibilities and those of co-workers before work begins.

An important aphorism—and fact—is, in order to sell PNE, you must know PNE.

The activities in Approaching the Customer are—

- Making initial contacts.
- Learning the business and mission.
- Developing contacts.
- Selling the value.
- Planning for PNE.
- Setting project roles and responsibilities.

## H.3.1 Making Initial Contacts

The types of customer contact are—

- Technical—
  - Engineering.
  - Security.
- Management—
  - Chief (executive, operating, information, or security) officer.
  - Program/project leader.

In an IS modification or development program, the most likely initial point of contact (IPOC) for the information systems security engineer is the customer's technical representative—an engineer, a software/systems administrator, or a member of the corporate security staff who requires help in information security. The IPOC can facilitate information gathering and other contacts within the customer's organization. Communicating with the decision makers, whose participation and support is critical to a successful information protection program, is especially important.

In many instances, the customer's system is not only defined but is also mature. Security happens to be an afterthought, and many decisions have already been made about the purpose and design of the system. Nevertheless, the PNE practitioner must do the homework, using the IPOC to gain further information from the documentation or through interviews with customer

personnel. A prime objective is to meet with the decision makers—the DAA, Chief Executive Officer (CEO), Chief Operating Officer (COO), Chief Information Officer (CIO), or senior program manager—for initial input. Obtaining approval to proceed with PNE as part of the customer's program will later require briefing these same decision makers on the PNE plan.

## H.3.2 Learning the Business and Mission

Before discussing any tasking with the IPOC, the PNE practitioner must gather as much customer data as possible:

- Organization.
- Objectives.
- Major functions.
- Products.
- Supporting and supported organizations.
- Future plans.

The PNE practitioner gains the confidence of the IPOC when he or she demonstrates knowledge of the customer's business and mission and comprehension of the customer's information management and protection needs.

Unless the organization has a sensitive mission or a very poor marketing division, a wealth of information is usually available:

- **Published Information:** Mission statements, organizational advertising, trade and news magazines, government directives, and the World Wide Web.
- **People Networks:** Team members of previous traceable projects, business and government associates, and customer advocates.
- **Current and Past Contracts or Requirements:** The *Commerce Business Daily*, Requests for Quote, and the Web site: <<http://cbdnet.gpo.gov>>. The PNE practitioner may receive assistance from his or her own marketing division or from those who track current and past Requests for Proposals/Requests for Quotes (RFP/RFQ) released by the customer.

## H.3.3 Developing Contacts

The PNE practitioner must build associations and trust with two valuable sources: initial contacts, including the IPOCs and the decision makers.

Initial contacts are important because of their—

- **Leverage With the Decision Makers:** The IPOC, a friendly insider, opens the door to the organizational network. In particular, the IPOC can work the system to make

appointments with other needed contacts—especially busy decision makers—and knows how to approach them. However, the practitioner should first use other contacts the IPOC recommends before taking up decision makers' time.

- **Inside Coordination:** The IPOC can help make appointments, explain the purpose of PNE, keep track of schedules, and help to build trust.
- **Access to Information Sources:** The IPOC will be a good source of information about the project.

The PNE practitioner should have at least three sessions—other than interim reporting meetings—with decision makers:

- Briefing them on the purpose of PNE and getting their views on requirements.
- Presenting the plan for providing services and getting a commitment.
- Presenting the results of the PNE.

The PNE practitioner must be prepared for meetings with decision makers by—

- **Optimizing Available Time:** Decision makers are busy; it is important to be brief and to the point and to present a rational approach to getting the job done. One strategy is furnishing decision makers with background material before meeting.
- **Scheduling Carefully:** Know what needs to be accomplished and let decision makers know what is expected of them and what resources are needed.
- **Defining PNE Benefits (see Section H.3.4):** Build a solid case for the PNE project and how it benefits the customer's program.
- **Requesting a Decision (see Section H.3.4):** At the second meeting, the practitioner presents the PNE plan and gets a decision.

## H.3.4 Selling the Value of PNE

Selling PNE requires an understanding of and a belief in its merits. An experienced practitioner can present both nonsecurity and security PNE benefits to a customer.

The nonsecurity benefits result from in-depth analysis of the information to be managed by any solution. The analysis results in an IMM of the workings of any solution and a detailed definition of desired information management needs. The nonsecurity benefits of PNE include—

- **A Better Understanding of Information Management.** PNE analysis results in a document that presents who manages what information using what processes or functions (see Section H.4). This analysis nearly always appeals to managers who rarely have thought about that aspect of their organizational activities. If the customer has done the analysis, PNE will increase ISSE team knowledge and provide an independent check.

- **Requirements Analysis Before System Analysis Begins.** The IMM is a tool for presenting requirements to the system architect—the quality and detail of the analysis removes most of the ambiguity. The analysis can save time and money and avoid operational surprises.
- **A Baseline for Evaluating Results.** Whether constructed by the PNE practitioner or by the customer and reviewed by the practitioner, the IMM is an important requirements control document. For ordinary configuration control and requirements tracing, the IMM is the baseline for evaluating the results—the operational performance of the solution.
- **Defining needed administrative resources.** The information-centric approach naturally leads to questions (and answers) about managing the solution and the administrative data to make it work. In particular, the {WHO, WHAT, FUNCTIONS, PROCESSES} approach evolves into a definition of the administration resources needed and the roles of all of the systems administrators.

The security benefits of PNE include—

- **Documentation of Threat.** By categorizing information, the IMM becomes the basis for examining threats to information. The PNE threat analysis investigates the motivation any adversaries might have to attack the information and the likely effect of an attack. By involving the customer, the analysis effects a realization of potential harm and of the value of the customer's information.
- **Documentation of Policy.** After recognizing the potential harm and the value of information, the customer can arrive at decisions about priorities for protection and security services. This part of the PNE results in an IPP that reflects the concerns and decisions of the customer.
- **Prioritized Protection.** The customer's priorities as stated in the IPP are valuable information for the security architect who must use available resources efficiently by allocating resources in proportion to threat.

### H.3.5 PNE Project Planning

The practitioner presents a PNE plan, with a budget, to the customer. The plan must be explained in the context of the customer's program and should include a justification in terms of benefits. The practitioner must show the customer the scope of the PNE effort (team and customer) to produce an IPP together with costs and schedule. The costs include those for both the PNE team and the required customer resources, such as IT, security, operations, and management personnel to meet with the PNE team, review documents, and make recommendations on policy and priorities.

The justification puts PNE in the context of the customer's program by stressing that information protection results from good requirements analysis. PNE benefits to the customer's risk management program include identifying potential losses and the potential reductions in risk. In

addition, the resulting IPP will inform the customer about resources needed to carry out the policy for security and administrative life-cycle security support (the IPP does not address nonsecurity system support).

## H.3.6 Setting Project Roles and Responsibilities

A project often faces obstacles if roles and responsibilities have not been assigned. Hence, the plan must identify all players and their expected contributions and commitment to the project. Typically, the major players are—

- Decision makers, who approve and direct the project.
- IPOCs (specifying the need for their continuing support throughout).
- Operations people (specifying the need for them to review and accept the requirements).
- Security administrators (specifying the need for them to define and coordinate support to the eventual system).
- Certifiers and accreditors (specifying the need for their involvement from the beginning and throughout the system's life cycle).
- The PNE team and its resources.

Completeness is important. Individuals must be specified to fulfill every project need. After the plan is submitted, the decision makers either accept the plan as is, request modifications, or reject the plan.

## H.4 Acquiring the IMM

Before a solution is selected, its function must be defined. It will manage information but what information will be managed, who will manage it, and what the managers do must be established.

This section describes the mechanics of modeling information management. The focus is on information rather than systems because the focus of the discipline is to produce a requirements analysis that is independent of solutions. The requirements documented will later be used to evaluate any proffered system solution in the ISSE process.

The topics in Acquiring the IMM are—

- **Information Management and Models**—The use of models is a proven technique for defining and exchanging concepts. Systems engineers use a variety of models as part of the design process. This

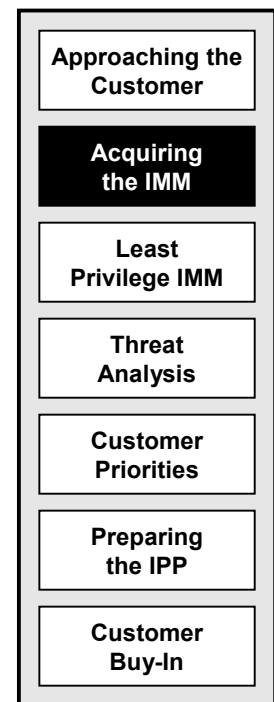

iatf\_h\_8\_0090

section deals with information management, modeling techniques, and the basic IMM.

- **What the Customer Has Already Done**—In the best possible scenarios, the customer has created or is creating a model of the desired information management. The job then requires the information systems security team to become familiar with the model. If the customer has not created a model, the information systems security team, regardless of the state of system development, must acquire the necessary information.
- **Description of IMM**—Data required by the IMM are best acquired by interviews and from documents. The techniques used during data gathering are discussed.
- **Other models**—
  - Integrated definition (IDEF).
  - IDEF with buffers and release.
  - IDEF modified.
  - Structured analysis model.
  - IMM table.
- **Why IMM is important.**

## H.4.1 Information Management and Models

The most primitive definition of “information management” is any method of—

- Creating information.
- Acquiring information.
- Processing information.
- Storing and retrieving information.
- Transferring information.
- Deleting information.

The word “processing” covers a broad set of manipulations of data that select, transform, reorganize, or otherwise process the many forms of data called information. Information management tools may be either off-the-shelf packages or custom applications.

Applying classic “structured analysis” [Yourdan] to information management yields the model in Figure H-9a. The basic model consists of users, processes, and information. The line connections imply that the user employs the process to manage the information. Any model can be expanded or decomposed into more complex models, as seen in Figure H-9b. The basic model can be decomposed but only according to specific rules. The decompositions of interest are those that create unique relationships among the three elements. Specifically, any deconstruction that does not change the users or the information category is typically uninteresting because of the least-privilege rule.

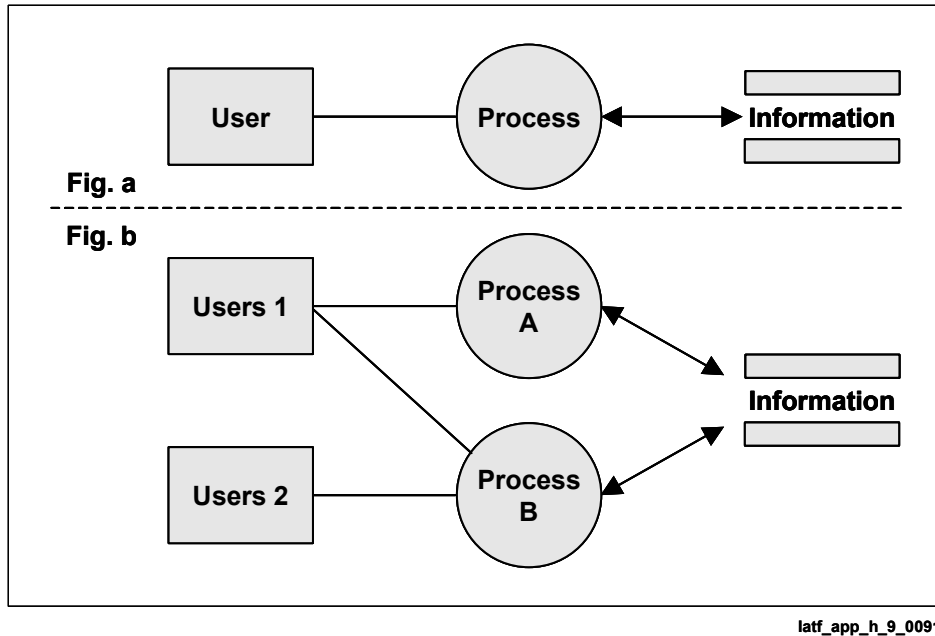

Figure H-9. Information Management Model

A complex model is technical data for systems people. The PNE practitioner should not use complex models to brief customers.

## H.4.2 What Has the Customer Already Done

A good systems engineering team will have documented much of the information needed. The PNE practitioner can discover whether the customer's systems personnel have analyzed and documented their systems requirements and information management. The IPOC can locate personnel operations who can access such documentation.

In general, there are three possibilities—

- **Information Management Already Modeled**—Discovering information management needs may be relatively easy because the customer has already done the work.
- **Model Needs Translation**—The second best situation is that the modeling has been constructed by the customer. However, this modeling may be inadequate and require additional information or restructuring. This situation may lead to fundamental changes in the customer model and, under the worst conditions, changes in customer design or the customer's assumed risk.
- **No IMM**—The PNE practitioner must do the research.



## H.4.3 Description of IMM

Another representation of the model in Figure H-9 is a table that includes users, process, and information (Table H-2). There is also a rules column, which later will be necessary for defining policy and user privileges; the information provided in this column may also save some work. There are multiple users, one process, and one information category.

**Table H-2. Simple Example of an IMM**

Users	Rules	Process	Information
CEO	Read, Write	Corporate Management	Policy
Employees	Read-		

In this example, corporate management informs employees about policy. In particular, the CEO manages corporate policy, but employees only see the policy. (The rules can be much more complex than those in this example.)

An important part of building the IMM is to acquire the information needed. The two methods that work best are conducting interviews and reviewing documents. The IPOC can be relied on to locate the documents or set up the interviews with knowledgeable customer employees.

Several interview sessions may be necessary. The PNE practitioner should always be sensitive to—

- **The Effects on Customer Operations.** Minimizing the effect on the customer's operations requires being prepared, knowing what is wanted, and making clear requests. Meeting with employees requires understanding that time is being taken from their other responsibilities—many with deadlines.
- **The PNE Project Schedule.** Meeting with employees according to their availability is inefficient. Realizing that not all interviewees will take the time to provide useful data in a timely manner, the PNE practitioner should use pre-interview questionnaires. Pointing out ways of familiarizing customers with project needs and being prepared to answer project-related questions is beneficial.

The best way of constructing the IMM is to identify the major functions of an organization and to decompose them into subprocesses—not only for functions directly related to products and services but also for internal support functions that may be affected by the solution, such as human resources, finances, business management, and research and development (R&D).

Decomposition should continue until the subprocesses yield no new subsets of users and their information; consolidating unnecessary decompositions later would consume precious time and effort. Typically, two decompositions to a third level are sufficient. Decomposition leads to increased detail and complexity. The customer and the information systems security team must determine the adequacy of definition. The customer may decide that further separation of users

and their privileges is unproductive and may even be counterproductive in contingency situations.

## H.4.4 Other Models

The customer may have completed several other types of models such as those listed below<sup>I</sup>

- Organization models.
- Data (information about operations, services, products) models.
- Process (describe flow of activities in business processes) models.
- Workflow (sequence of human activities) models.
- Financial (mostly spreadsheet) models.
- Simulation (detailed representation of activities) models.

These models can be a source of information for creating the IMM. The IMM models Organization, Data, and Process.

It is useful to compare the IMM with the IDEF model and the structured analysis model.

### H.4.4.1 IDEF

The IDEF model [IDEF] is one often used in information systems development. There are software tools that produce IDEF models. The model can be modified to become an IMM. The Input Data and Output Data arrows are typical dataflows. Resources arrows typically contain reference material or even system support data. Users and Policy/Rules are part of the Control arrow.

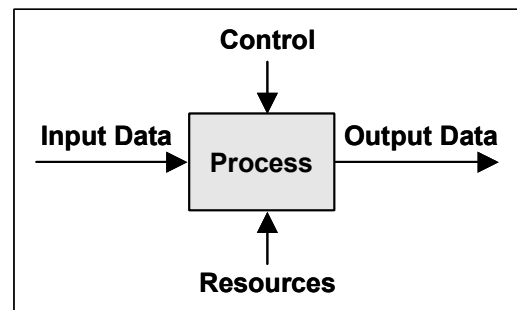

If the customer has used IDEF model, the PNE practitioner will need to modify it.

The example in Figure H-10 originated from an intrusion detection reporting system. This model, which emphasizes processes and the flows between them, consists of three processes, three sets of users, and possibly three policies.

<sup>I</sup> [Taylor] is the source for the bulleted items

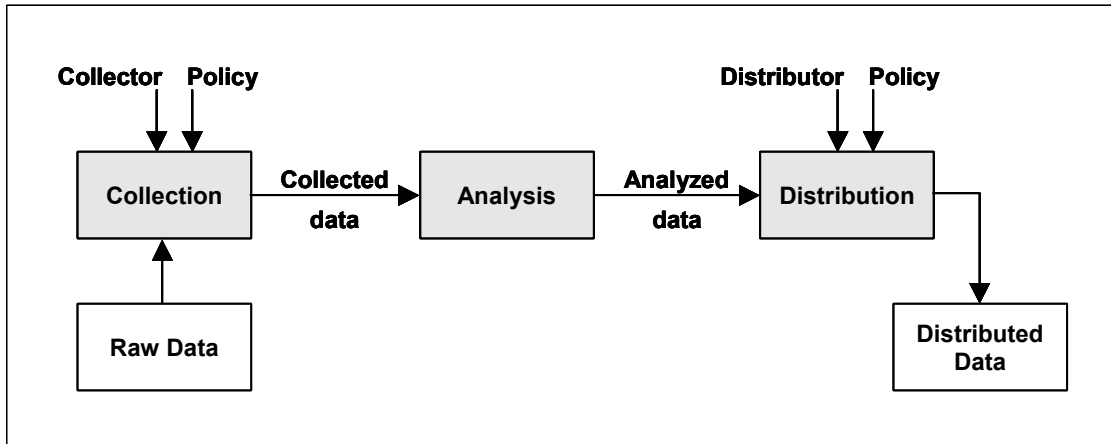

latf\_app\_h\_10\_0092

**Figure H-10. IDEF Model Example**

The three policies are not illustrated, but typically processing is partial—that is, only *some* of the—

- Raw data are forwarded as collected data for analysis.
- Processed collected data are analyzed for distribution.
- Processed analyzed data are distributed.

The movement of collected and analyzed data between processes is what is of interest from a security perspective. From a policy standpoint, it may be important to know what data are shared and who authorizes the sharing. This example needs better definition of policy and information sharing. One way to be explicit about policy is to show buffers—information stores—for each process and insert release processes, as shown in Figure H-11.

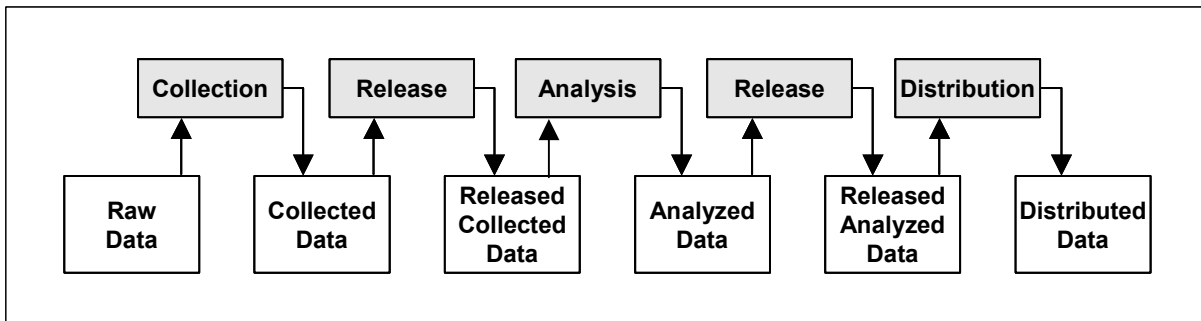

latf\_app\_h\_11\_0093

**Figure H-11. IDEF With Buffers and Release**

This initial modification, an excessive decomposition, remains consistent with IDEF but is a better representation for information management and protection. The arrow directions start to imply some flow or access definitions. The added data stores also raise questions about the allowable release, release controls, and sharing of data. At this point it is important for the customer to insert any rules and information about sharing and control. Figure H-12 shows the resulting fully modified model.

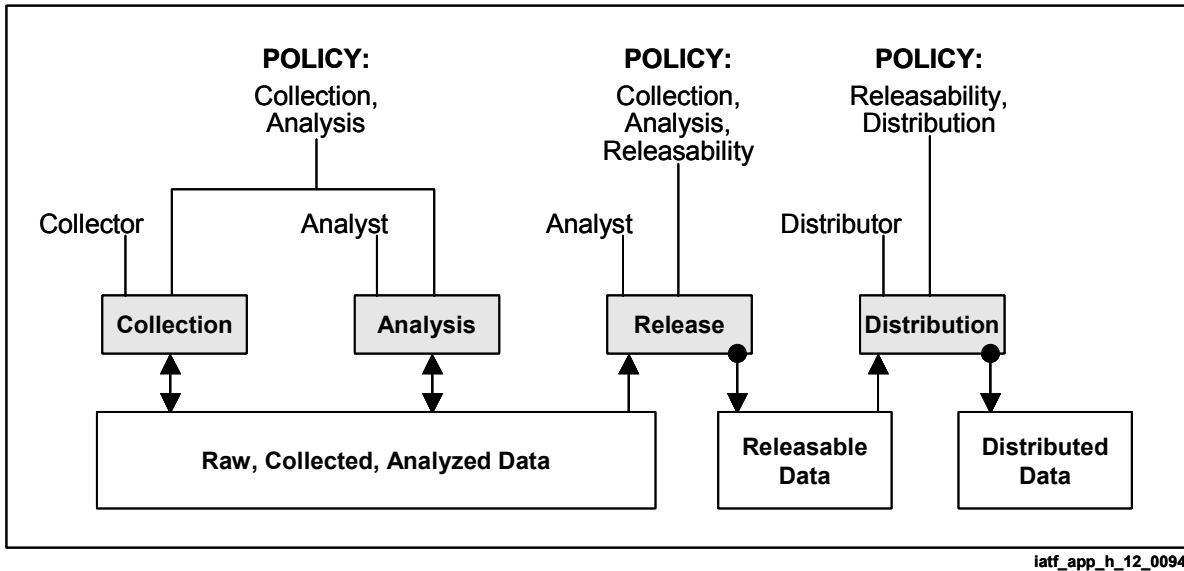

**Figure H-12. IDEF Modified**

The customer expresses no concern about whether the collector and analyst can manage the combined raw, collected, and analyzed information from a security perspective. In particular, although there may be a data-type separation, there is no need for a security separation. Also, the customer has decided that not all of the analyzed information can be released and relies on the analyst to decide what is releasable.

The arrow directions, important in both this and the next model, indicate the customer's rules. The dots replacing arrows at the ends of some lines indicate that the customer "doesn't care." The analyst uses the release process to make copies available to the distributor in a separate "releasable data" store. The distributor, using this access, distributes to the rest of the community, maintaining a record of what was distributed. The modified model makes explicit a policy of separation, user privileges, and data sharing; the arrowheads imply the rules.

## H.4.4.2 Structured Analysis

The model in Figure H-12 can be illustrated in the traditional structured analysis format: User—Process—Information seen in Figure H-13. This model contains the same information as the modified IDEF model.

## H.4.4.3 IMM Table

A third variation is tabular (see Table H-13), preserving all of the elements, users, rules, processes, and information. The same information management activity has been exhibited in the IDEF, structured analysis, and table models in Figures H-12 and H-13, and Table H-3. There is no "correct" way to model, but all the important elements must be present.

*Note:* The PNE practitioner should not attempt to use these often-complex models to brief a decision maker. They are tools only.

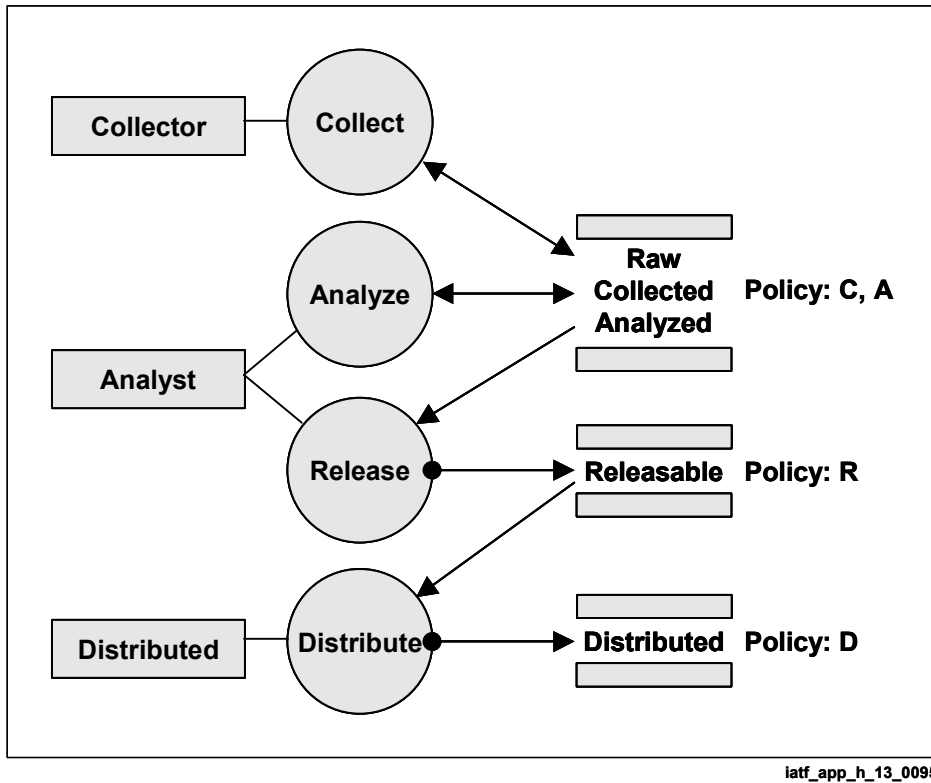

Figure H-13. Structured Analysis Model

Table H-3. Table Model of IMM

ID	Users	Rules	Process	Information
Policy CA	Collector	Read, Write	Collection	Raw Collected Analyzed
	Analyst	Read, Write	Analysis	
		Read	Release	
Policy R	Analyst	(Read), Write	Release	Releasable
	Distributor	Read	Distribution	
Policy D	Distributor	(Read) Write	Distribution	Distributed

( ) means: the action is permitted but not essential.

Annex A is an example of an IMM developed for a division of a corporation producing business forms. The content and depth of analysis of this IMM are valuable. That IMM also includes a

threat analysis (see Section H.6) and partially based on the same issues expressed in the corporate IPP (see Section H.8), as seen in Annex B.

## H.4.5 Why IMM Is Important

The finished product, the IMM, defines the information management to be accomplished by the solution in the desired detail:

- Who—Users, Rules.
- Does (or intends to do)—Rules, Process.
- With what information.

With a completed IMM, the information systems security team and the customer can begin to analyze what is and is not really necessary. It is the first stage in defining access control and privileges. The IMM is also a baseline for threat analysis, at the desired level of specificity, and for security services:

- Identification and authentication.
- Access control.
- Confidentiality.
- Integrity.
- Availability.
- Nonrepudiation.

In some cases the IMM will suggest to designers and customers simplifications that can be made by consolidating similar information categories or by relaxing the rules slightly to allow categories to be consolidated.

## H.5 The Least-Privilege IMM

“Least privilege” is a security-related concept that has practical value even without considering specific threats to information. A generic threat might be stated as “The more people who have access to information, the greater the probability of abuse.” This guidance document takes the following position:

Security protection is better when only those who need access to information are allowed access.

This section discusses aspects of modifying the IMM—

- **Least-Privilege Concept**—defines and explains it.
- **Consolidation**—demonstrates this IMM modification.
- **Information Domains**—explains how to set them up.
- **Revised IMM**—demonstrates completion.

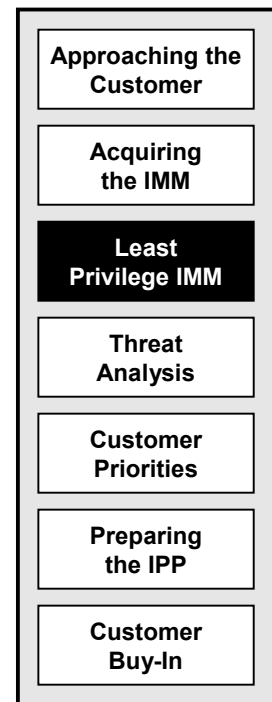

iatf\_h\_8\_0090

This section also discusses two types of errors that may occur when an IMM is—

- Assigning unnecessary privileges.
- Creating unnecessary separations.

## H.5.1 Least-Privilege Concept

The decomposition process applied in developing the IMM accomplishes a major part of least-privilege control: The user-process-information segments were separated with the sense of “This set of users has some role in this process, and they manage this information.” Applying least-privilege also sets out—

- Services and activities limited to those who are essential to meeting responsibilities. Under least-privilege, roles are examined more carefully and any unnecessary privileges are removed.
- Justifiable complexity. The removal of privileges may lead to additional complexity in system design and ultimately to user frustration. Maintaining a close relationship with eventual users and obtaining their guidance and acceptance is very important.

Assignment of privileges stems from a Concept of Operation that associates people (users) with their jobs (processes). Users do the job; they need the information. Table H-4 depicts an accountant putting together financial records. The CEO, or even the CFO, probably will not have the time to manage the information directly, but from a management perspective they can see the big picture better. Notice that there may be an advantage to taking away the CEO’s “write” privileges.

**Table H-4. Least-Privilege Example**

Users	Rules	Process	Information
CEO	Read, Write	Corporate Finance	Investments, Customer accounts
Accountant	Read, Write		

## H.5.2 Consolidation

Examining the IMM will often reveal unnecessary separations of (user, process, information) categories. At this point the PNE practitioner should ask the customer to consider combining the categories. Table H-5 shows two sets of (users, process, information) categories with everything being equal except the information.

**Table H-5. Categories Before Consolidation**

Users	Rules	Process	Information
Group Manager	Read, Write	Corporate Management	Directives, Correspondence
Division Manager	Read, Write		

Users	Rules	Process	Information
Group Manager	Read, Write	Corporate Management	Progress Reports
Division Manager	Read, Write		

Information need not be separated for access control so these categories may be combined (Table H-6). Later, if it is discovered that the two information sets have different threats and security service requirements, they would be separated again.

**Table H-6. Categories After Consolidation**

Users	Rules	Process	Information
Group Manager	Read, Write	Corporate Management	Directives, Correspondence, Progress Reports
Division Manager	Read, Write		

### H.5.3 Information Domains

A unique set of [users, rules, processes, information] is an example of what DoD has defined as an “information domain” (DoD Goal Security Architecture [DGSA]). Though this is not a critical term, the PNE practitioner should understand the concept because it underlies the IPP. The concept is explained further in the DGSA (see References).

An information domain is a set of unique—

- Members of the domain—users.
- Information objects.
- Security policy identifying the relationships between members, information objects, and the security services required to protect the objects, such as least privilege.

Table H-7 displays an example of an information domain.

**Table H-7. Information Domain Example**

Domain	Users	Rules	Process	Information
Administration: Corporate	Group Manager	Read	Corporate Management	Directives, Correspondence, Progress Reports
	Division Manager	Read		



The PNE practitioner should watch for mistakes like read only or write only, meaning there are no writers or no readers in the domain. In the example, someone must prepare the information, so read only is not possible.

The rules are relatively simple; real-world policies on user privileges are more complicated. New rules are discovered with each new application of PNE.

The set of all information domains together forms the revised IMM.

## H.5.4 Revised IMM

The PNE practitioner should document and coordinate the revised IMM, also called the least-privilege IMM, with all interested parties. Because it collects all information domains, the revised IMM can be very detailed. The practitioner must identify the important reviewers and their availability. As many issues as possible should be flushed out—especially with operations personnel—before any remaining issues are sent to the decision makers.

When the revised IMM is completed, the PNE practitioner is ready for threat analysis.

## H.6 Threat Analysis

Once everything the solution is supposed to do is understood in significant detail, the information systems security team needs to investigate security, beginning with an information threat analysis. With the customer as the principal source for data, the PNE practitioner analyzes information threats in each domain in the following ways:

- **Identifying Harm to Information (HTI)**—The term **Harm To Information** is shorthand for **harm to the mission or business through attacks on the information**. Helping the customer identify the most to least valuable information and the types of harm that would result if it were exploited. Likely impacts to the customer's business or mission will establish priorities for protection. The PNE practitioner should ensure that all of the information domains are ranked.
- **Identifying Potentially Harmful Events (PHE)**—Helping the customer identify adversaries who might harm valuable information, the adversaries' motivations, the type of harm they might attempt, the sources of nonmalicious threats; and helping the customer to measure the likelihood of each type of adversarial attack (essentially, the adversary's motivation level) or nonmalicious harmful event.

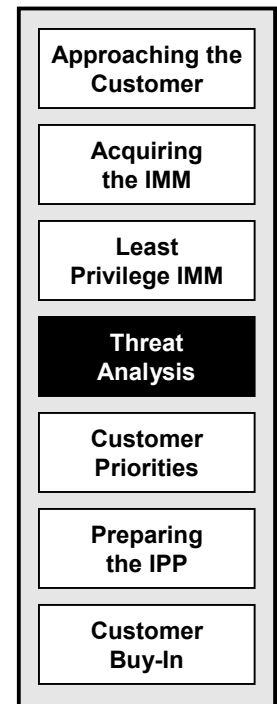

iatf\_h\_8\_0090

- **Combining HTI and PHE to Estimate Information Threat**—Analyzing and combining the HTI and PHE for each information domain listed in the IMM.

## H.6.1 Identifying Harm to Information

Examining each information domain begins with helping customers to assess its value. The value of information is viewed in many ways in the information protection community, but mainly it relates to the costs of replacing information or some other (typically non-information-system) asset if information is harmed. The PNE practitioner shows customers the types of possible harm to their information. Some are easily understood (see Figure H-14):

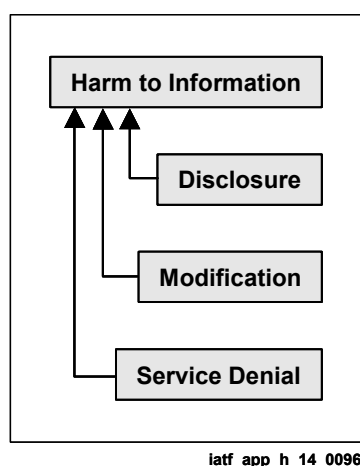

**Figure H-14. Types of Harm to Information**

- Disclosure, or loss of confidentiality.
- Modification, or loss of integrity.
- Nonavailability, or loss of access or service.

Other types of harm are more obscure—

- Repudiation, or loss of authenticity, leading to—
  - Denial of receipt of information.
  - Denial of sending information.

Customers can easily relate to the costs of replacing information that might be destroyed or corrupted or regaining the competitive edge lost by exposure of secrets. They will have difficulty evaluating possible loss of life. They can even assign a value to recovering from harm to their reputations. The PNE has four scales for defining harm: none, mild, significant, serious. The practitioner should use whatever metric scales the customer is comfortable with.

In helping the customer assign a metric value to information or to the effects of information exploitation for each information domain, some pertinent questions to be asked are—

- Is the harm none, mild, significant, or serious?
- If you [the customer] had to rebuild files, would that be no harm or serious harm?
  - How long would it take you to rebuild damaged files?
  - What would you not be doing while you were rebuilding damaged files?
  - Would this lost or delayed effort be significant or serious?
- If a discovery that you substantially invested in were stolen by your competitor, what would be lost?
  - How could you recover?
  - Is the cost of recovery significant or serious?
  - Is future lost revenue significant or serious?
- If a competitor acquired yesterday's stock values, would the impact be serious or not?

## H.6.2 Identifying Potentially Harmful Events

PHE may be caused by either nonmalicious or malicious threat sources or by adversaries. Nonmalicious threat sources (see Figure H-15) are natural disasters and accidents.

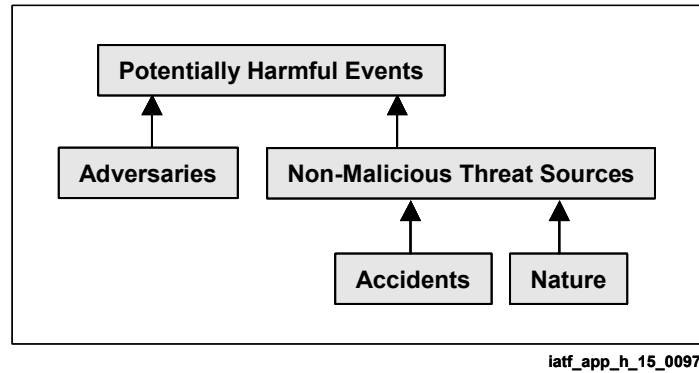

**Figure H-15. Sources of Potentially Harmful Events**

The PNE practitioner must also draw the customer's attention to a list of potential adversaries, such as those with past histories of attacks on others with a similar business or mission. Statistical reports of attacks will help with assigning probabilities. Types of adversaries that may attack information are—

- Competitors.
- Persons engaged in industrial espionage.
- Foreign governments.
- U.S. government employees and insiders.
- Hackers.
- Intruders.
- Criminals.

The PNE practitioner should present the customer with some examples of adversarial motives (see Figure H-16) for attacks—

- Sabotaging the business or mission by—
  - Destroying a capability.
  - Interfering with functions.
  - Destroying information.
  - Misleading or confusing a rival.
- Embarrassing or discrediting a rival.

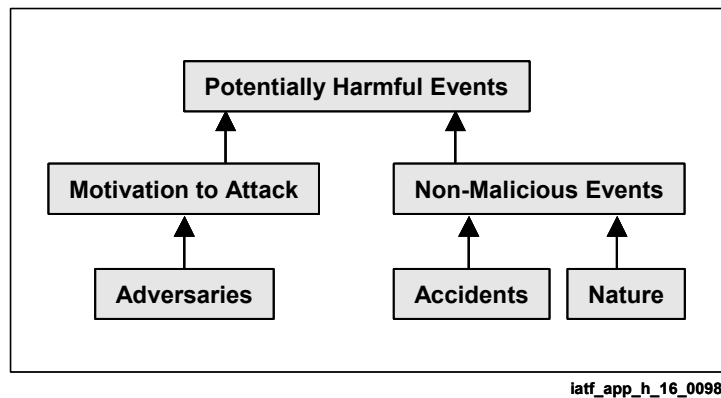

**Figure H-16. Adversaries**

- Seeking monetary gain by—
  - Gaining knowledge.
  - Stealing ideas.
  - Stealing services.
- Acting out of curiosity or seeking notoriety.

The customer who understands adversaries and their motivations must then make a decision on the likelihood of adversaries, their motivation level, and finally PHEs (probabilities driven primarily by motivation). The four categories of PHE are none, low, medium, and high. To quantify these, the practitioner should use a metric scale the customer is comfortable with.

It is not realistic to assume that a solution will always provide protection. For example, one cannot assume that loss of data is not a problem because every system has backup capability. This protection-needs analysis may show the need for a backup capability. Two examples—

- An accountant at the telephone company is thinking of establishing a cost-free account for personal calls and calls by friends. What is the probability of a PHE—none, low, medium, or high?
- Files get corrupted by a power surge. What is the likelihood of this nonmalicious event—none, low, medium, or high?

At this stage (see top of Figure H-17), neither system nor security mechanisms have been defined. Hence, no notion of vulnerabilities exists, and a risk assessment cannot be performed.

### **H.6.3 Combining HTI and PHE to Estimate Information Threats**

The PNE practitioner uses previous analysis and estimates to prepare two tables similar to those (all data artificial) in Table H-8: one for PHE and one for HTI, both with headings for InfoDomain (domain name), Disclosure, Loss/Modification, Denial of Service, and Repudiation. The results of the estimation of PHE and HTI domain are then placed in the tables.

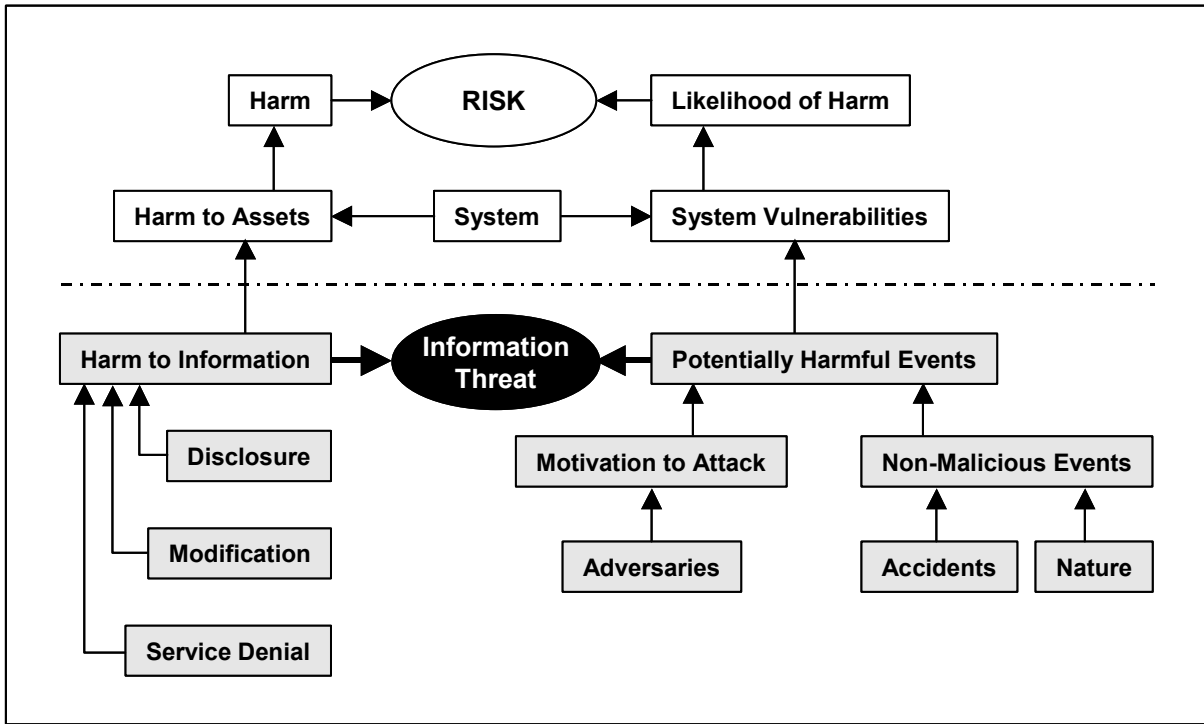

iatf\_app\_h\_17\_h017

Figure H-17. Information Threat

Table H-8. PHE and HTI Measures

Potentially Harmful Events				
InfoDomain	Disclosure	Loss/Modification	Denial of Service	Repudiation
Strategic planning	Medium	Medium	Low	None
Customer advocacy	High	Medium	Low	None

Harm To Information				
InfoDomain	Disclosure	Loss/Modification	Denial of Service	Repudiation
Strategic planning	Serious	Mild	Mild	None
Customer advocacy	Significant	Mild	Mild	None

The question then is, How can the measures of PHE and HTI be combined to express a combined information threat metric? The four types of quantitative data (the metrics) with measurement scales are shown in Table H-9.

**Table H-9. Information Threat Data**

Quantitative Data	Scale
Harm To Information—impact	None, Mild, Significant, or Serious
Potentially harmful event—a probability	None, Low, Medium, or High
Information threat—combining HTI and PHE	0, 1, 2, 3 (3 denotes highest information threat)
Strength of security service (described later)	None, Minimum, Moderate, or Strong

The PNE approach to combining PHE and HTI is the two-dimensional matrix shown in Table H-10—

- Row headings contain the HTI scale.
- Column headings contain the PHE scale.
- Matrix entries, combining PHE and HTI to produce information threat, are chosen from the scale {0, 1, 2, 3}.
  - 0 denotes lowest information threat.
  - 3 denotes highest information threat.

**Table H-10. Information Threat Combination Matrix**

		PHE			
		Measures	None	Low	Medium
HTI	Serious	0	2	3	3
	Significant	0	1	2	3
	Mild	0	1	1	2
	None	0	0	0	0

The numbers chosen should reflect commonsense situations (e.g., if there is no impact, any PHE results in no information threat). It is important to note that the matrix or other combining methodology is really an indication of the customer’s preference, guided, of course, by the PNE practitioner.

For each information domain and for each type of harm—

- Look up the value at the intersection of the PHE and HTI (see Table H-10).
- Record the results in a table (see Table H-11).

**Table H-11. Information Threat Table (ITT)**

Information Domain: Strategic Planning			
Disclosure	Loss/Modification	Denial of Service	Repudiation
3	1	1	0

The final results of the threat analysis are the detailed ITT tabulation by information domain of the importance of each type of harm to information. It is important to also record the rationale that supports the results and that justifies the selected PHE and HTI values. After completing the ITT, the PNE practitioner advises the customer of cooperatively developed findings and should be prepared to present the findings to decision makers for any adjustments.

The briefing to decision makers consists of—

- Summarizing the results when briefing.
- Illustrating unusual highs and lows.
- Explaining any other anomalies.
- Presenting any unresolved issues.
- Receiving the reactions and expressed priorities of the decision makers, who now begin to decide what is important.

## H.7 Customer Priorities

Analysis of threats to the customer’s information management must be presented to decision makers in a way that gives them the opportunity to know and accept or modify the results. The analysis results in coarse metrics that reflect the level of concern about attacks on each kind of information managed. The results desired from the briefings are to discover any changes in priorities and to achieve consensus.

The PNE practitioner achieves the desired consensus by—

- Presenting the threat analysis.
- Obtaining the customer’s view.
- Managing reactions.
- Setting priorities

### H.7.1 Presenting the Threat Analysis

Threat analysis results are typically presented to decision makers. Because the presentation is critical to the acceptance of the recommended method, the PNE practitioner

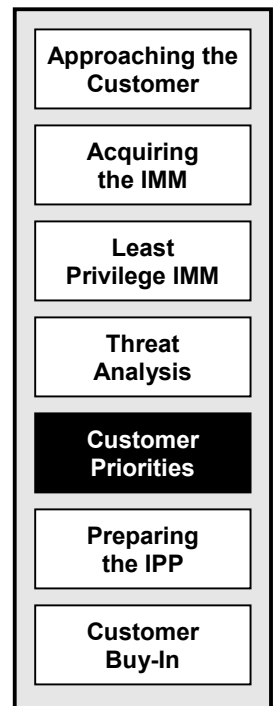

iatf\_h\_8\_0090

should—

- Present a coordinated result. The whole ISSE team and the decision makers' staffs should have had input.
- Present IMM and threats with minimal detail. The presentation should focus on the highest level of concerns and summarize the findings.
- Explain how to interpret any tables used.
- Increase depth as necessary. The full report should be available for any customer who desires to review it. The presentation should be structured so that backup material with finer detail and samples of the information are available.
- Present issues and recommendations. Any unsolvable issues that surfaced in working with operations or systems personnel should be presented to the decision makers for their judgment.

## H.7.2 Obtaining the Customer's View

The customer will want to know what the PNE team found to be the most important problems and will expect that the PNE team will have documented lesser problems as well. The threat matrix shown in the threat analysis section, if used, will rank the information threat for each domain as a 3, 2, 1, or 0. Present all the 3s and 2s and be prepared to at least categorize the 1s and 0s. Record customer reactions to each problem, and note whether the customer agreed or disagreed.

## H.7.3 Managing Reactions

Feedback on the threat analysis needs careful management. The ISSE team should assure the customer that the results will be amended to reflect their decisions. The ISSE team should—

- Advise and be open to the customer's views. The ISSE team advises and guides the customer, the customer's opinion is paramount. Minority opinions should be reported but not acted on unless the customer so directs.
- Be prepared for disagreements. If decision makers disagree with the results, they should be informed that the results reflect the findings of the customer's staff as well as the information systems security team. When there is disagreement, be ready to accept less than the information systems security team's judgment. Make a record of the disagreement.
- Remind the customers that the results will reflect their decisions. Inform the customer that changes will be made to reflect the decision maker reactions to the briefing.



## H.7.4 Setting Priorities

The goal of PNE is to capture the customer's priorities. The ISSE team should—

- Use the results of initial analysis. Make sure that the customer is aware of the documentation of the results.
- Amplify reasoning. Be ready to supply a rationale for the results from the threat analysis. Case histories are especially helpful.
- Encourage discussion. The highest priority items will probably receive the most reaction. Encourage the decision makers.

## H.7.5 Achieving Consensus

Full consensus may not be possible at the initial threat analysis presentation. The ISSE team should—

- Document the results and circulate them as often as necessary for review and comment at the highest levels of operation and decision making.
- Use meetings, if possible, to discuss and report progress.

## H.8 Preparing the IPP

The Information Protection Policy is the authoritative requirements document for the development and security life cycle of an information protection solution, whether it is called an IPP or some other name. What matters is that it contain the information necessary to help the security architect to satisfy protection needs. In preparing the IPP, the PNE practitioner should—

- Explain the Purpose and Type of IPP. “Policy” has many definitions.
- Identify existing policies, regulations, and procedures. In preparing the IPP, the PNE practitioner must be aware of all documents that pertain to security policy. The IPP should not conflict with, and indeed might be governed by, existing policy. Other security administrative needs can also be accomplished by including them in the IPP.
- Establish roles and responsibilities. The IPP can define how it should be revised and maintained and by whom.



iatf\_h\_8\_0090

- Identify decision makers. The signatures on the IPP identify which authorities or decision makers support the policies. The IPP can prescribe an administrative structure for assuring proper implementation.
- Define C&A procedures. The IPP can be the source for administering C&A procedures.
- Identify Security Service Requirements. The major purpose of the IPP is to document the security services required to counter identified threats to information.
- Document results.

## H.8.1 Explain the IPP Purpose and Type of IPP<sup>2</sup>

Security policies have a wide range of definitions and purposes. The purposes range from compliance with international treaties, to prescribed computer user behavior, to rules for a reference monitor in a trusted computer. Stating the purpose of a policy in the document is the only way to distinguish it from other policies.

Policy should not define how something is to be accomplished. Policy should document only what is to be accomplished—the requirements. The purpose of the IPP is to document the security services required to counter identified threats to information. Other potential sources of protection requirements, a mix of “what is required” and “how to do” types of documents—, are—

- International agreements and treaties.
- Government laws, statutes, and directives.
- Organizational directives.
- Operational agreements.
- IT system controls and procedures.
- Workstation controls.
- Doctrine.

Doctrine is often considered policy but is really part of the architecture and implementation. Doctrine includes all of the procedures, personnel administration, physical security specifications, and so forth needed to support the hardware and software design. Auditing, for example, is a doctrinal procedure used to detect compromises or violations of policy.

## H.8.2 Identify Existing Policies, Regulations, and Procedures

The PNE practitioner should—

---

<sup>2</sup> Section 1.1 in Annex B and Section 1.1 in Annex C are examples.

- Budget research time while building customer relations and before writing the IPP. In the IT business, most security policies are a mix of procedures, guidance, rules, and design specifications. Read and understand the structure and content of existing policy.
- Analyze procedures, guidance, and rules to discover the underlying policies. Procedures do have underlying policy. For example, the statement, “must use six-character passwords for login,” implements a requirement for a minimum-to-moderate strength I&A service.
- Retain and transfer any solutions to be used as possible design constraints. Solutions also have underlying policy. When a mechanism is identified in the existing documentation, record the fact for later analysis by the systems designer.

### **H.8.3 Establish Roles and Responsibilities<sup>3</sup>**

To ensure that the IPP is properly maintained, the PNE practitioner should—

- Identify existing security functions and resources and establish relationships. Organizations most likely have information or property protection rules in place, for example, assigned resources and organizational responsibilities for nightly lockup, paper file separations, financial auditing, or other safety requirements. The information management solution must coexist with these existing security measures. The information management solution may, in fact, be intended to augment or replace existing measures. Discover them and establish working relationships with those responsible for them.
- Identify resources for policy changes and enforcement. The IPP is useful as a vehicle for identifying its own maintenance and enforcement structure. A policy administrator will need to coordinate changes and manage the enforcement resources.
- Identify security evaluators, certifiers, and accreditors, and their responsibilities. An important issue for decision makers is choosing who will evaluate and certify that the solution provides adequate protection, and who will accredit any system as operationally acceptable.
- Suggest a security administration staff and define staff responsibilities. The IPP can be used to define a complete administrative staff for life-cycle support of itself and the IPP consistent with customer functions. Implementing the security management can be delayed until the system is designed, but the merit of placing it in the IPP is that resources can be authorized to help define the system. Typical staff roles are—
  - Chief Security Officer (CSO).
  - Office/unit/area security officers.
  - Network security administrators.
  - Security domain administrators.
  - Information domain administrators.

---

<sup>3</sup> Section 2.3 in Annexes B and C are examples.

## H.8.4 Identify Decision Makers

Identify decision makers, involve them and their staff members in the PNE process, and have them review the PNE at critical points. The IPP is the final documentation of the PNE. It must incorporate the results of the decision makers' previous decisions. Because the signatures on the IPP should be those of the authoritative decision makers, they must have the final review before signing. Typically, in a corporate structure, the CEO, CIO, COO, and CSO are the decision makers; in the DoD, the DAA is the decision maker.

## H.8.5 Define C&A Procedures<sup>4</sup>

Ultimately, someone must decide whether to accept and allow the use of new or modified information systems. The decision will be based partly on a determination that the solution adequately meets the information protection requirements stated in the IPP. The IPP can serve as the vehicle to force the decisions about who is the accreditor, the evaluator, and the certifier and to obtain their agreement to perform those roles. Many programs have been delayed or cancelled because these decisions were not made early enough, or at all. It is a good idea to recognize any specific certification & accreditation (C&A) process that is useful or organizationally dictated (e.g., DITSCAP). Documentation of procedures and decisions may be in the IPP itself or be included by reference.

## H.8.6 Identify Security Service Requirements<sup>5</sup>

There are some confusing overlaps between mechanisms that provide security services and the security services themselves. It may be helpful to consider a security service as a 'category of security mechanisms'. Security services include:

- Access control (in storage).
- Confidentiality (in transit).
- Integrity (in transit).
- Availability (of information and service).
- Nonrepudiation (proof of origin and delivery).
- Identification and authentication.
- Security management.

A mechanism for one security service may contribute to another security service. An access control mechanism can provide confidentiality and integrity services. Confidentiality mechanisms can provide access control and integrity services. One recommendation is to consider the access control mechanism as the security service for protecting information in storage, and confidentiality and integrity mechanisms as the security services for information in

---

<sup>4</sup> Section 2.4 in Annex B and Section 2.5 in Annex C are examples.

<sup>5</sup> Section 2.6 in Annex B and Section 3 in Annex C are examples.

UNCLASSIFIED

transit. Of course, I&A mechanisms support the other security services. Security management is considered a security service.

The main activity of the PNE is to identify specific information protection requirements in terms of—

- Each information domain.
- Each security service needed.
- The strength of each needed security service compared to each type of harm (copied from the Threat Analysis section)—
  - Disclosure, or loss of confidentiality.
  - Modification, or loss of integrity.
  - Nonavailability, or loss of access or service.
  - Repudiation, or loss of authenticity—
    - Denial of receipt of information.
    - Denial of sending information.

Table H-12 lists each of four types of harm with an information threat (rated as 0, 1, 2, or 3) specified for the strategic planning information domain.

**Table H-12. Information Threat Table**

**Information Domain: Strategic Planning**

Disclosure	Loss/Modification	Denial of Service	Repudiation
3	3	1	0

The activity is to assign a security-service strength combination to each type of harm, in which the scale for strength of the security service is none, minimum, moderate, or strong. The practitioner should use a metric scale that the customer is comfortable with. Table H-13 lists four types of quantitative data, or metrics, with measurement scales.

**Table H-13. Information Threat Data**

Quantitative Data	Scale
Harm To Information (HTI)—impact	None, Mild, Significant, Serious
Potentially Harmful Event (PHE)—a probability	None, Low, Medium, High
Information Threat—combining HTI and PHE	0, 1, 2, 3 (3 denotes highest information threat)
Strength of Security Service	None, Minimum, Moderate, Strong

In this appendix we assign a security-service strength to a type of harm using the look-up tables in Figure H-18 and Table H-14:

Type of Harm	Security Service	Target <sup>6</sup>
Unauthorized access	Access control	Any data or system component
Disclosure	Confidentiality	Any data or process
Modification/damage	Integrity	Any data, process, or component
Denial of service/use	Availability	Any data, process, or component
Spoofing/Denial	Non-repudiation	Proof of origin or delivery of data
False authorization <sup>7</sup>	Authentication	Authentication data or decision
Unauthorized control	Security management	Security management data

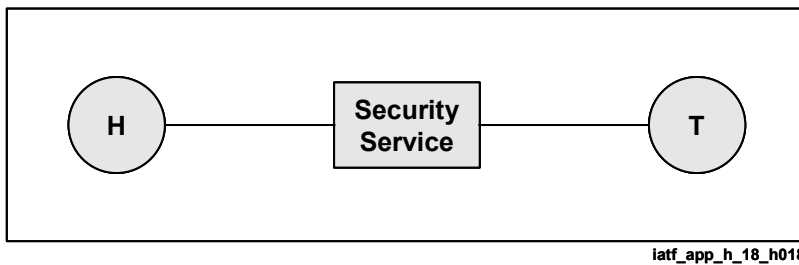

iatf\_app\_h\_18\_h018

**Figure H-18. Map Type of Harm to Security Service**

**Table H-14. Map ‘Information Threat’ to ‘Strength’**

Information Threat	Strength of Security Service
0	None
1	Minimum
2	Moderate
3	Strong

For each information domain and for each type of harm, map the information threat to a security service strength.

Note two assumptions in this approach—

- Within an information domain, the strength of the security service needed to protect against a type of harm is proportional to the information threat to that type of harm.
- The strength of I&A and security management security services must be commensurate with the strongest of the other security services in the information domain.

Table H-15 contains the results for strategic planning.

<sup>6</sup> The Target column is provided for reference only.

<sup>7</sup> The False authorization and Unauthorized control rows are provided for reference only.

**Table H-15. Data for Information Protection Requirements**

Information Domain Strategic Planning	Disclosure	Loss/ Modification	Denial of Service	Repudiation
Information Threat	3	3	1	0
Security Service	Confidentiality	Integrity	Availability	Nonrepudiation
Strength	Strong	Strong	Minimum	None

The two special requirements for the example are that—

- All system components and data require a strong level of I&A protection.
- All security-management data require a strong level of security management protection.

## H.8.7 Document Results

The final product of PNE is an IPP, in whatever documented form, that defines—

- Information management.
- Threats to information management.
- Security services priorities.
- Authoritative direction.

The well-prepared IPP provides a wealth of information for design and for C&A, but it is a living document that must be periodically reviewed and updated.

## H.9 Customer Buy-In

The final step in the PNE process is achieving the customer’s agreement to maintain and enforce the IPP and to provide the resources and agents needed for its execution. Customer support of this agreement is crucial for—

- Defining a solution consistent with the IPP.
- Developing a system consistent with the system security requirements as allocated from the IPP and the security architectures.

To obtain buy-in, the PNE practitioner must—

- Explain ownership (again). The final product, the IPP, is an internal document owned by the customer. Make sure that the customer understands that the IPP is the customer’s policy, not the PNE practitioner’s policy.

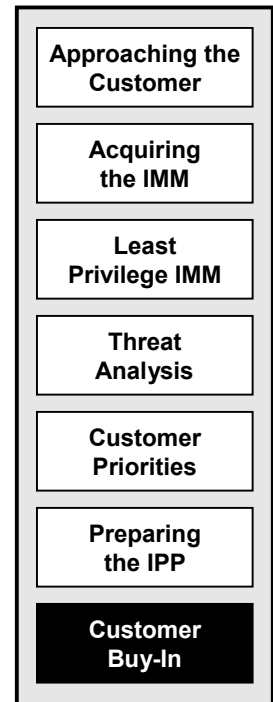

iatf\_h\_8\_0090

- Explain the need for high-level endorsement. Management and leadership must be the driving force. An IPP that is not supported by management is a total waste of effort.
- Explain the need for maintenance. The IPP must be reviewed periodically because it must change as changes occur in the mission, the business, or the system.
- Explain the need for necessary resources. The customer must identify and apply resources to maintain the IPP effectively.

## **H.9.1 Explain Ownership (Again)**

If the correct procedures have been followed, the PNE practitioner should already have buy-in, with the customer participating by—

- Contributing information.
- Reviewing and commenting on documents.
- Making decisions that resolve issues.

The IPP, therefore, documents the customer's desires and decisions.

## **H.9.2 Explain the Need for High-Level Endorsement**

The customer must understand that the IPP represents the rules not according to the information systems security engineer but according to the customer. Without the power of the decision makers behind the IPP, no protection program exists. The decision makers' signatures are evidence of coordinated approval.

## **H.9.3 Explain the Need for Maintenance**

Changes will occur. The IPP should be self-sustaining by its own content. Therefore, the signed IPP should identify and approve the procedures necessary to keep it active and current.

## **H.9.4 Explain the Need for Necessary Resources**

The IPP should also be self-sustaining in terms of its resources. Therefore, the signed IPP should identify and approve the resources necessary to support the customer's mission.



## H.10 Summary

PNE provides a detailed description of the first and perhaps the most important activity of ISSE. It engages customers to become the source and the advocates for protecting their own information. The seven procedures from Approaching the Customer to Customer Buy-in provide a solid foundation for the next ISSE activity—Define System Requirements—where the systems context, concept, and requirements are defined.

# PNE Glossary and Acronym List

C&A	Certification and Accreditation
CEO	Chief Executive Officer
CIO	Chief Information Officer
COO	Chief Operating Officer
CSO	Chief Security Officer
DAA	Designating Approval Authority. One of the signatories of the System Security Authorization Agreement in the Department of Defense certification and accreditation process.
DGSA	Department of Defense Goal Security Architecture
DITSCAP	Department of Defense Information Technology Security Certification and Accreditation Process.
DoD	Department of Defense
HTI	Harm to Information
IA	Information Assurance
I&A	Identification and Authentication
IAS	Information Assurance Solutions. An NSA (security) process for finding security solutions.
IATF	Information Assurance Technical Framework
IDEF	Integrated DEFinition
IMM	Information Management Model. The IMM represents everything that an information system should accomplish. The IMM can be used to check consistency and to evaluate the actual system. A comprehensive developed IMM is the starting point for information protection, but very often the PNE practitioner must develop the IMM, which defines “who does what with which information objects.”

## UNCLASSIFIED

Appendix H  
IATF Release 3.1—September 2002

INFOSEC	Information Systems Security. This acronym also breaks out to “Information Security” and means classification management within that community, although not in this document.
IPOC	Initial Point of Contact
IPP	Information Protection Policy. The PNE practitioner produces the IPP (a form of security policy) as the final result of PNE. The IPP represents the latest requirements and decisions of the customer concerning information protection. It belongs to the customer, not to the PNE practitioner.
IS	Information Systems
ISSE	Information Security Systems Engineering. The primary skill needed in PNE is systems engineering with a specialty in information security.
IT	Information Technology
ITSEC	Information Technology Security
ITT	Information Threat Table
ND186	Network Defend 186. A National Cryptologic School course.
NSA	National Security Agency
PHE	Potentially Harmful Events
PNE	Protection Needs Elicitation
PP	Protection Profile. Part of the Common Criteria language.
R&D	Research and Development
SE	System Engineering
SSAA	System Security Authorization Agreement. The document capturing a system’s certification details and accreditation status in DITSCAP.
TOE	Target of Evaluation. Part of the Common Criteria language.

# References

[DGSA] DoD Goal Security Architecture, Version 1.0 ,Defense Information Systems Agency, October 1993.

[IDEF] IDEF modeling, <[www.edef.com](http://www.edef.com)>.

[Taylor] Taylor, David A. Business Engineering with Object Technology, John Wiley and Sons, 1995.

[Yourdan] Yourdan, Edward. Modern Structured Analysis Yourdan Press, 1989.

**UNCLASSIFIED**

Appendix H  
IATF Release 3.1—September 2002

**This page intentionally left blank**

# **PNE Annex A: IMM Example**

---

[This annex to this document is an unedited (except for company name) example of an actual IMM.]

**XYZ Corporation**

**Business Forms Division**

## **INFORMATION MANAGEMENT MODEL**

*A composite understanding of XYZ, Business Forms Division's information, and information management, with threats analyzed and information domains determined.*

**UNCLASSIFIED**

Appendix H, Annex A  
IATF Release 3.1—September 2002

**This page intentionally left blank**

# Executive Summary

## XYZ Business Forms Division

### Information Management Model (IMM)

The XYZ Corporation Information Protection Policy (IPP) (draft: dated ..... ) provides the policy on information protection and provides guidance for the preparation of policies by divisions of the corporation. This Information Management Model (IMM) has been prepared in accordance with the procedures defined in the XYZ IPP for the XYZ Business Forms Division (BFD). It is a source document for XYZ BFD's Information Protection Policy (IPP).

This document, XYZ BFD's IMM, is the result of—

- 1) Modeling the division's information management functions.
- 2) Considering corporate policy.
- 3) Analyzing more specific threats.
- 4) Revising the model to meet existing policy and to partially counter any specific threats.

The IMM is a logical description of information management which depicts the users, processes, information, and information flows which support the business. The threat analysis from the examination of the IMM by information category of its potential for harm, the impact of harm to business, and the selection of needed security services. The XYZ IPP had defined relevant threats, impacts, and security services applicable to all XYZ divisions. The information categories of the IMM were reorganized into information domains (refer to definitions) wherein security services were applied to the users, processes, and information categories. Each information domain contains an element of policy. The IMM was used as the basis for the XYZ BFD Information Protection Policy (IPP). That IPP is the composite of the defined information domain protection policies and forms the basis for subsequent security architecture recommendations.

The development of this IMM resulted in the formation of 47 information domains. This included 44 user types/roles 48 types of processes, and 124 information categories. The choices made for XYZ BFD were influenced heavily by the following set of priorities:

- customer service.
- protection of customer information.
- protection of XYZ's proprietary information.
- protection of XYZ's financial information.
- separation of customer accounts information.

With a few exceptions, the threat of disclosure is not significant to XYZ BFD. The threat of unauthorized modification is significant. Most domains were formed with this threat being the most prominent from both a potential harm and impact perspective. The denial of



service/availability threat is relevant to various XYZ BFD processes and information, but only has a serious impact upon the customer ordering. The authentication of users is essential in supporting all security services.

## 1.0 Introduction

Before any information systems engineering process begins an Information Management Model (IMM) must exist or be developed. The IMM provides the basis for all future analysis and is necessary to understand the information systems requirements. This IMM provides an understanding of XYZ's information; what information is managed, who manages it, what processes utilize and modify it, and what transfers occur.

IMMs are developed in one of two contexts: the as-is or the to-be. In the as-is, the IMM is derived from existing systems and applications and correlated with business functions as they are currently organized and implemented. This is useful in documenting the as-built system's IMM. In the to-be, the IMM is derived from re-engineered or new business processes and business flow. Information description, structure, categorization, flow, and management controls are derived from the newly engineered, or existing re-engineered business functions. The to-be IMM is the target IMM.

This document presents the target IMM for XYZ's XYZ Business Forms (XYZ BF) and Systems Division (SD). The focus is on the XYZ BFD re-engineered business processes. However, both the as-is and the to-be have been used, because the target IMM is a composite of old and new XYZ BFD processes and information.

This IMM documents the information in terms of users-processes-information and information flow. Using the XYZ Corporation Information Protection Policy a threat analysis is performed upon the IMM resulting in a revised IMM with information domains. An information domain is a set of unique users-processes-information, where the privileges associated with any user on any information object in that domain are the same for all information objects. Information domain security policies and a composite security policy are presented in the XYZ BFD's Information Protection Policy.

## 1.1 Background

XYZ's XYZ BFD is re-engineering its core business areas for improved performance and reduced cost. This re-engineering will result in new information, revised business processes, and new information technologies with distributed computing.

This document is one in a series of documents that XYZ's XYZ BFD will receive under the management consulting arrangement with our firm. This document has been developed under a consulting engagement task entitled XYZ Security Policies and Standards.

The XYZ Security Policy and Standards consulting task will develop and deliver:

- The XYZ Corporation Information Protection Policy;
- XYZ BFD's Information Management Model;
- XYZ BFD's Information Protection Policy;
- System Security Architecture recommendations for the XYZ BFD division.

The XYZ Corporation Information Protection Policy provides the guidelines for information protection services for all of XYZ's divisions. The XYZ BFD's specific information protection documents follow these guidelines. XYZ BFD's information protection standards documentation is a useful model for other XYZ divisions.

## 1.2 IMM Development Approach

The IMM is developed by decomposing users-processes-information, and logical information flows to where the set of users and their roles are uniquely different. Using the XYZ Corporation Information Protection Policy a threat analysis performed upon this set *users-processes-information* resulting in a revised IMM with information domains. This document will form the basis of the XYZ BFD's Information Protection Policy.

## 1.3 Sources Of Information About XYZ BFD IMM

The sources of information for developing the IMM came from existing documentation and from interviews with XYZ employees and XYZ-local Data Center contractor employees. Documentation includes summary information of existing applications, project ABC report, the XYZ Corporation Annual Report, and XYZ Business Process Re-engineering project (understanding the business). Figure 1.3.1 highlights the IMM development approach and information.

## 2.0 XYZ BFD IMM Decomposition

XYZ BFD top level information management model is illustrated in Table 2.0.1. The top level processes include both core business processes and infrastructure (or resource management) processes which support the core business processes.

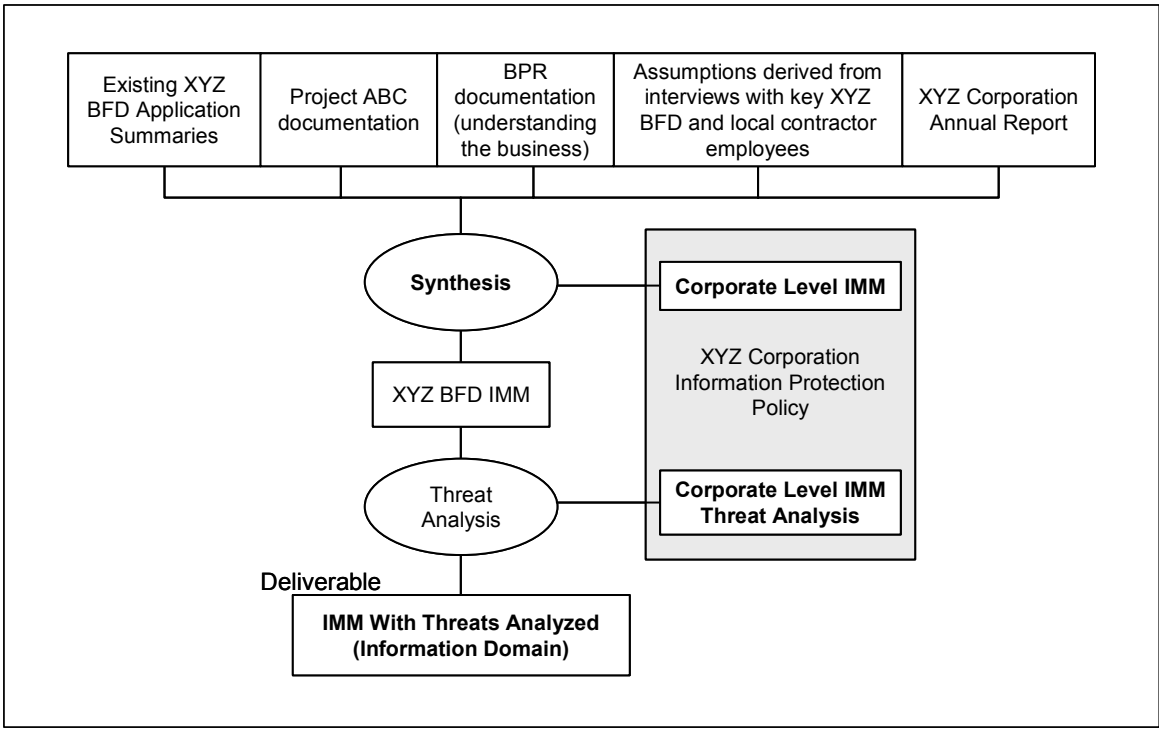

latf\_ann\_a\_001

**Figure 1.3.1. IMM Information Sources & Development Approach**

The XYZ BFD core business processes include:

- Customer Ordering
- Information Inquiry
- Manufacturing
- Warehousing

The XYZ BFD infrastructure processes include:

- Business Planning
- Marketing
- Finance and Accounting
- Personnel Management
- Information Systems and Communications Management
- Facilities Management
- Corporate Relations
- Security Management

**Table 2.0.1. Top Level XYZ BFD IMM**

<b>USERS</b>	<b>PROCESS</b>	<b>INFORMATION</b>
Customers, XYZ Employees	Customer Ordering	Customer Profile and order entry/order process info
Potential Customers, Customers, XYZ Employees	Inquiry	General catalog, customer profile, oe/op info
XYZ Employees, Suppliers, Customers	Manufacturing	Manufacturing Process Management Info Customer New Forms Design Info
XYZ Employees, Customers	Warehousing	Shipping, Receiving, and Inventory Control Info
XYZ BFD Executives & Staff	Business Planning	Planning Info
Sales/Marketing Staff & Executives	Marketing	Marketing Info and General Catalog Updates
Finance/Accounting Staff & Certain Executives	Finance & Accounting	AR/AP/GL Info
Personnel Staff	Personnel Management	Personnel Files, Policies & Procedures, Payroll Info
IS/Comm Management & Operations Staff	Is/Comm Management	IS/Comm Planning, System & Network Management, and Ops Info
Office Managers Admin Staff	Facilities Management	Office Supplies Accounting Facilities Maintenance. Monitoring Info
XYZ BFD and Corp. Executives	Corporate Relations	Reporting Information
XYZ BFD Security Managers/Administrators	Security Management	Security Management Information

The XYZ BFD IMM decomposition begins from this level of abstraction, preceding downward until the logical groupings no longer have any unique user and user role variations. For this reason, some process classes and information categories must be decomposed to a finer resolution than others. For example, both the business planning and corporate relations infrastructure processes, users, and information end at level 1. There is no refinement necessary beyond level 1 because there are no clarification of the users and user roles at a finer granularity than level 1, at least none that we uncovered during our analysis of these two XYZ BFD processes.

## 2.1 Customer Ordering Process Decomposition

The order process described is based on the XYZ BPR project “Understanding the Business” Document, because it is the most current description of the future. The level 2 decomposition is summarized in Table 2.1.1. The level 3 decomposition is summarized in Table 2.1.2.

**Table 2.1.1. Customer Ordering Process Level 2 Decomposition**

USERS	PROCESS	INFORMATION
Potential Customers, Customers, Sales Reps, Sales Center Reps	Identification	Customer Profile
Potential Customers, Customers, Sales Reps, Sales Center Reps	Profile Management	Customer Profile
Potential Customers, customers, sales reps, sales center reps, xyz manufacturing, warehouse, and finance employees	Order Entry Order Processing	Customer Profile, New Forms Design, POs/Releases, Read- only Price Quotes
Potential Customers, Customers, Sales Reps, Sales Center Reps	Order Adjustment	POs/Releases and Customer Order File
Potential Customers, Customers, Account Managers, Account Representatives	Inquiry Process Link	Customer Profile, New Forms Design, POs/Releases, Order File, Price Quotes

The identification process identifies the customer by name, account number, or phone number. The information is contained in the customer profile. If the customer is new, they will be deferred to the profile management process to develop a new customer profile. Input to the identification process comes from interactive customers or EDI transactions. EDI transaction input is for existing customers only, and must include adequate identification information and order process request information to process the EDI transaction. Existing customers, after identification, are prompted for the particular ordering process sub-process they wish to use, if

the user is interactively connected to the identification process. This is described in the XYZ Direct ordering process. The identification process does not have a level 3 decomposition.

**Table 2.1.2. Order Entry and Order Process Level 3 Decomposition**

USERS	PROCESS	INFORMATION
Customer, Sales Rep, Sales Center Rep, Manufacturing Forms Designer	New Forms Design	Customer catalog, general catalog, new forms image
Sales Rep, sale center rep, no users	Price Quote	Price ranges file, freight/shipping price file, customer concessions info and po (complete or partial)
Customer, sales rep, sales center rep	Activate Order or Release	Trigger/Status Info and Orders File

The profile management process allows a new customer to build a customer profile, and allows an existing customer to modify information in the customer profile. The content of the customer profile information is defined in XYZ Direct documentation. Some of the information in the customer account is controlled by the customer, other information may be read but not modified by the customer, and other information (i.e., credit approval/disapproval information) may not be viewed by the customer, but is necessary to activate an order.

The order entry and order processing processes allow the user to order XYZ BFD products, design new forms products, get price quotes prior to activating an order, set an automatic reorder cycle, and release inventory stored in a warehouse to be shipped to the customer. The customer interface to this process is by way of the Triage concept, or via EDI transaction, after passing through the identification process.

The order adjustment process allows the customer to change or cancel an activated purchase order or release instruction. The customer interface to this process is by way of the Triage concept or EDI transaction, after passing through the identification process.

The inquiry process is a level 1 process, with linkage from the customer order process. This link is by way of the Triage concept or via EDI transaction, after passing through the identification process. Users may also engage the inquiry process without entering the ordering process, but are to general inquiries that do not relate to a specific customer account. The inquiry process is detailed in section 2.2.

The level 3 decomposed processes of the order process are all associated with order entry and order processing.

The new forms design sub-process of the order entry and order processing processes allow a customer, customer surrogate, or interactive customer/manufacturing forms designer to develop

new forms. The price quote sub-process provides the user with a quoted price affiliated with a particular order. The activate order/release sub-process allows a trigger to send the order or release to manufacturing or warehousing for completion.

## 2.1.1 Customer Ordering Process Threat Analysis and Information Domains

The customer ordering processes and information have two needs. The first is to verify the identity of users for controlling access. The second is to control accessibility and privileges to certain order processing information for confidentiality and integrity reasons. Three guidelines are used to determine ordering process information domains. The guidelines are as follows.

- With the exception of the identification process, all other sub-processes of the customer ordering process require that the user's identity and/or EDI transaction content origin be authenticated. The other guidelines cannot be enforced without user identification and authentication and/or EDI transaction data origin authentication.
- Keep each customer's information separate from other customers' information to minimize the threats of disclosure to unauthorized users and modification by unauthorized users.
- Identify read and write privileges associated with all customer ordering processes and information to minimize the threats of unauthorized disclosure to the customer representative or unauthorized modification by the customer representative.

From the XYZ Corporation Information Protection Policy:

### Sales

**Threats:** Sales information about non-standard pricing arrangements offered to specific customers, or planning for special sales or agreements is threatened by disclosure (medium) and loss or damage (medium). The impact of disclosure or loss is (mild)

**Security Services:** This sales information requires confidentiality (minimum) and integrity (minimum) in both storage and transfer. Access control (minimum) must limit information entry and disclosure to XYZ sales personnel and information disclosure to only the specific customers involved. I&A (minimum) is required to support the other security services.

### Customers

**Threats:** Information about customers wherein accounts, customer profiles, ordering histories, and customer proprietary information is unique to that customer are threatened by disclosure (medium) and loss or damage (medium). The impact of disclosure of customer proprietary information is (serious) and the disclosure of other customer information is (significant)

**Security Services:** This customer information requires confidentiality (moderate) and integrity (moderate) in both storage and transfer. Access control (moderate) must limit information entry and disclosure to XYZ specific sales personnel and information disclosure to only the specific customers involved. I&A (moderate) is required to support the other security services.

## Orders

**Threats:** Information about orders may contain unique pricing arrangements with (medium) threat of disclosure and (medium) threat of loss or damage. The impact of disclosure is (significant) and of loss or damage is (mild).

**Security Services:** This ordering information requires confidentiality (moderate) and integrity (minimum) in storage and transfer. Access control (moderate) should limit access to specific customers, specific salespersons, specific sales managers, and any financial information users.”

The three extractions relate to the XYZ BFD ordering process. From this analysis, five information domain types are concluded. These five information domain types are summarized in Table 2.1.3.

**Table 2.1.3. Order Process Information Domains**

DOMAIN	USERS	RULES	PROCESS	INFORMATION
ORDER Identification	Anyone		Identification	
ORDER Profile Management [1 per account]	New customer	Write	Profile Management Create profile	Customer profile - Customer's info
	Sales representatives	Auth: read/write		
	Account mangers	Auth: read/write		
	Account representatives	Auth: read/write	Profile management Modify profile	
	Customer	Auth: read/write		
	Sales representatives	Auth: read/write		
	Account mangers	Auth: read/write		
	Account representatives	Auth: read/write		
	Warehouse employees	Auth: read		
	Manufacturing employees	Auth: read		
Finance employees	Auth: read			
ORDER Pricing [1 per account]	Customer rep	Auth: read	Profile Management Price quote	Customer Profile - Pricing info
	Account/sales reps	Auth: read		
	Account mangers	Auth: read		
	Warehouse employees	Auth: read		
	Manufacturing employees	Auth: read		
	Finance employees	Auth: read/write		



**UNCLASSIFIED**

Appendix H, Annex A  
IATF Release 3.1—September 2002

<b>DOMAIN</b>	<b>USERS</b>	<b>RULES</b>	<b>PROCESS</b>	<b>INFORMATION</b>
ORDER Credit Checking [1 per account]	Account mangers	Auth: read	Profile Management - Credit check - Credit approval flag	Customer Profile - Credit info
	Account/sales rep	Auth: read		
	Finance employees	Auth: read/write		
	Finance managers	Auth: read/write		
	Marketing managers	Auth: read		
	Marketing representatives	Auth: read		
	XYZ BF executives	Auth: read		
ORDER Entry and Processing [1 per account]	Customers	Auth: read/write	Order Entry & Order Processing  (Linkage to inquiry)	Customer Profile orders releases new forms
	Account/sales rep	Auth: read/write		
	Account manager	Auth: read		
	Warehouse employees	Auth: read		
	Manufacturing employees	Auth: read		
	Finance manager	Auth: read		
	Finance employees	Auth: read		

## 2.2 Inquiry Process Decomposition

The inquiry process allows XYZ’s existing and potential customers and XYZ’s employees to gather information on XYZ’s products and services, inventories, and the status of existing orders. This information can be accessed through the XYZ Direct Triage, via EDI, direct connections, or through XYZ’s internal IS. The users and information associated with this process are shown in Table 2.2.1 which expands upon the Inquiry information shown in Table 2.0.1.

**Table 2.2.1. Inquiry Process Top-Level Decomposition**

<b>USERS</b>	<b>PROCESS</b>	<b>INFORMATION</b>
Potential Customers	Inquiry	Offering (Catalog)
Customers		Order Status
XYZ Employees		Quotes
		Inventory
		Financial
		Customer Profile

The information in Table 2.2.1 is further decomposed into groups of processes with common sets of users and data. This decomposition is shown in Table 2.2.2.

**Table 2.2.2. Inquiry Process Level 2 Decomposition**

USERS	PROCESS	INFORMATION
Potential Customers	Offering inquiry	Offering (catalog)
Customers	Request for quote	Order status
XYZ Sales reps	Inventory inquiry	Quotes
XYZ Account Manager		Inventory
XYZ Account Exec.		
XYZ Financial Employees		
XYZ Marketing Employees		
Customers	Order Status Inquiry	Order status
XYZ Sales reps		Customer profile
XYZ Account manager		
XYZ Account exec.		
XYZ Sales reps	Financial Requests	Payment history
XYZ Account manager		Customer profile
XYZ Account exec.		
XYZ Financial employee		

From the XYZ Corporation Information Protection Policy:

## Marketing

**Threats:** Marketing information wherein sales people promote products and service to customers and potential customers, assess markets, quote standard pricing, and acquire information about the competition is threatened (medium) by the possibility of information being lost or damaged. The impact of such loss is considered (mild) requiring an investment in the rebuilding of the information.

**Security Services:** Marketing information shall be protected for data integrity (minimum). Confidentiality is not required. Access controls (minimum) must limit information entry to XYZ personnel with some exceptions for customer inquiry records.

## Customers

**Threats:** Information about customers wherein accounts, customer profiles, ordering histories, and customer proprietary information is unique to that customer and threatened by disclosure (medium) and loss or damage (medium). The impact of disclosure of customer proprietary information is (serious) and the disclosure of other customer information is (significant)

**UNCLASSIFIED**

Appendix H, Annex A  
IATF Release 3.1—September 2002

**Security Services:** This customer information requires confidentiality (moderate) and integrity (moderate) in both storage and transfer. Access control (moderate) must limit information entry and disclosure to XYZ specific sales personnel and information disclosure to only the specific customers involved. I&A (moderate) is required to support the other security services.

**Orders**

**Threats:** Information about orders may contain unique pricing arrangements with (medium) threat of disclosure and (medium) threat of loss or damage. The impact of disclosure is (significant) and of loss or damage is (mild)

**Security Services:** This ordering information requires confidentiality (moderate) and integrity (minimum) in storage and transfer. Access control (moderate) should limit access to specific customers, specific salespersons, specific sales managers, and any financial information users.

**Warehousing/Distribution/Transport**

**Threats:** Information about inventories of products, shipping schedules, carriers, transfers and disposals is threatened by loss or damage (low) but has (significant) impact on service to customers.

**Security Services:** This information is in access (moderate) to authenticated (minimum) customers, and XYZ employees. Integrity (moderate) in storage and transfer and confidentiality (minimum) in transfer is required.

Analyzing Table 2.2.2 with the above threats applied shows that the information in the level two decomposition must be further decomposed to provide separation of general inventory information from customer-specific inventory information. The result of that decomposition is shown in Table 2.2.3.

**Table 2.2.3. Inquiry Process Level 3 Decomposition**

USERS	PROCESS	INFORMATION
Potential customers	Offering inquiry	General XYZ inventory
Customers	Request for quote	Catalog
XYZ Sales reps	Inventory Inquiry	
XYZ Account manager		
XYZ Account exec.		
XYZ Financial employees		
XYZ Marketing employees		
Customers	Inventory inquiry	Customer-specific inventory
XYZ Sales reps	Request for quote	
XYZ Account manager		
XYZ Account exec.		

## 2.2.1 Inquiry Process Threat Analysis and Information Domains

The decomposition of the inquiry process results in four sets of user-processes-data. These sets must to be examined for threats as described in Section 2.6 of the XYZ Corporation Information Protection Policy. These threats may not represent all of the threats to the XYZ BFD Division; therefore, the four sets must also be examined for other potential threats. Also, the XYZ Corporation Information Protection Policy provides for the minimum set of probabilities of attack, degrees of impact, and security strength ratings, which in some cases may be higher for the XYZ BFD Division. A general determination is that all customer-specific information must be in separate information domains.

The first domain is order status & inventory. The information in this domain is associated with inquiries into the status of a customer's order. Part of that inquiry process interacts with the customer's profile to get information necessary to display the order status. The XYZ Corporate Policy states that the threat to the disclosure and/or loss of customer information, including ordering information, is medium and the impact of disclosure of a customer's information is serious. The policy also states that access to customer information must be to that customer and to specific XYZ sales personnel who are associated with that customer. Also, as this is an inquiry process, all users are to only reading the information and therefore cannot alter or damage the information. Table 2.2.4 shows this information domain.

The second domain is Financial Requests. This domain is associated with financial inquiries into payment history and the customer profile. The XYZ Corporate Policy shows that the disclosure of customer information is considered serious. Further, the policy states that access to financial information must be even within XYZ. The users associated with this domain are XYZ personnel. In addition, those with the ability to write or generate this information must be restricted. The privileges reflect this restriction. This domain is shown in Table 2.2.4.

The third domain is Inventory and Quotes. This domain is associated with inquiries into catalogs and requests for standard quotes. The information in this set is restricted to XYZ. The XYZ Corporate Policy expresses the concern with the loss, damage, and integrity of this information. The policy further requires that entry of this information be restricted to XYZ personnel only. XYZ's marketing personnel are the only users who can write into this information domain; all others have read-only privileges which meets this requirement. The information domain is shown in Table 2.2.4.

**Table 2.2.4. Inquiry Process Information Domains**

DOMAIN	USERS	RULES	PROCESS	INFORMATION
INQUIRY Order Status & Inventory (1 per order)	Customers (specific)	auth: read	Order Status Inquiry	Order-Specific
	Account Rep (specific)	auth: read	Inventory Inquiry	Customer Inventory
	Account Manager (specific)	auth: read		
	Account Exec.	auth: read		
INQUIRY Financial Requests	Account Reps (specific)	auth: read	Financial Requests	Payment History
	Account Manager. (spec)	auth: read		Customer Profile
	Account Exec. (specific)	auth: read		
INQUIRY Inventory & Quotes	Potential Customers (any)	read	Inventory Inquiry	General XYZ Inventory
	Customers (any)	read	Request for Quote	Quote
	Account Reps (any)	read		Catalog
	Account Manager (any)	read		
	Account Exec. (any)	read		

## 2.3 Manufacturing Process Decomposition

The manufacturing process from Table 2.0.1 is decomposed into forms design, production control, operations management, engineering, and distribution as shown in Table 2.3.1. There are three major aspects of manufacturing supported by information management; the customer's view of the status of his orders, the management's view of business performance, and the management of production.

**Table 2.3.1. Manufacturing Process Level 2 Decomposition**

<b>USERS</b>	<b>PROCESS</b>	<b>INFORMATION</b>
Customers Sales representatives Sales managers Managers Design engineers	Forms Design	Forms catalog, new forms customer orders
Customers Sales representatives Sales managers Operations staff	Operations	Customer orders schedules business plans manufacturing plans product inventories
Managers Production control staff	Production Control	Customer orders, Schedules Providers
Managers Suppliers	Raw materials management	Material inventories, Material orders, Suppliers invoices
Managers Maintenance staff	Engineering	Equipment data, Engineering notes Maintenance schedules
Customers Sales representatives Sales managers Managers	Distribution	Schedules, carriers, Invoices, inventories, Warehousing data

## 2.3.1 Manufacturing Process Threat Analysis and Information Domains

From the XYZ Corporation Information Protection Policy:

### Manufacturing/Vendors/Supplies

**Threats:** Information about products, inventories, requisitions, vendor and supplier contracts, production schedules, is threatened by disclosure (low) and loss or damage (medium). The impact of disclosure is (mild) and of loss or damage is (significant).

## UNCLASSIFIED

Appendix H, Annex A  
IATF Release 3.1—September 2002

**Security Services:** This information is in access (moderate) to authenticated customers (minimum) and XYZ employees. Confidentiality in transfer (minimum), and integrity in storage (moderate) is required.

Although a third level decomposition of the manufacturing process would be useful for information management modeling, the analysis for information protection purposes resulted in satisfactory definition at the second level. The results are shown in Table 2.3.2.

The manufacturing-catalog items information domain addresses the need for inquiry into the manufacturing status of catalog items by nearly anyone and allows for information update and monitoring by operations and production control personnel.

The manufacturing-customer orders information domains are established to provide the inquiry by customer order of any needed manufacturing response and permits the update and monitoring of that status information by manufacturing personnel.

The manufacturing-raw materials domain is information of concern only to manufacturing personnel with the exception of financial accounting which is dealt with in that process.

The manufacturing-distribution domain records information about carriers and warehouses. The actual shipping and invoicing are accomplished under manufacturing-catalog items and manufacturing-customer orders updates.

Manufacturing-design supplements the forms design activities which can be accomplished under the customer ordering process. Completed designs are placed in the catalog.

The manufacturing-operations information domain is used to prepare the manufacturing planning and reporting to XYZ BFD management in association with business planning. Manufacturing operations personnel have many responsibilities in the other manufacturing information domains.

The manufacturing-production control information domain controls the internal scheduling of personnel and equipment for production, including maintenance of equipment. Production control also acquires the services of external manufacturing and service providers herein referred to as “providers.”

**Table 2.3.2. Manufacturing Process Information Domains**

DOMAIN	USERS	RULES	PROCESS	INFORMATION
MANUFACTURING Catalog Items	Potential Customers	read	Inquiry	Catalog Item Inventories, Production schedules, Shipping Schedules Invoices
	Customers	read		
	Sales Representatives	read		
	Sales Managers	read		
	Operations Managers	read	Mfg. Std. Items Update	
	Production Managers	read		
	Operations Staff	read, write		
	Production Control Staff	read, write		
MANUFACTURING Customer Orders  (one/cust)	Customers (specific)	auth: read	Inquiry	Customer Orders Inventories, Production Schedules Invoices  Shipping Schedules New Forms Requests
	Sales Representatives (customer's)	auth: read		
	Finance & Accounting	auth: read		
	Sales Managers	auth: read		
	Operations Managers	auth: read	Mfg. Customer Orders Update	
	Production Managers	auth: read		
	Operations Staff	read, write		
	Production Control Staff	read, write		
	Design Engineers	auth: read		
MANUFACTURING Raw Materials	Managers	auth: read	Raw Materials Management	Material Inventories Material Orders Suppliers Info
	Operations Staff	read, write		
	Production Staff	read, write		
	Finance & Accounting	auth: read		
MANUFACTURING Distribution	Operations Managers	auth: read	Distribution	Carriers Info Warehouse Info
	Production Managers	auth: read		
	Production Control Staff	read, write		
MANUFACTURING Design	Design Engineers	read, write	Forms Design	Forms Catalog
MANUFACTURING Operations	Operations Managers	read, write	Operations	Manufacturing Plans
	Operations Staff	read, write		
	XYZ BFD Executives	auth: read		
MANUFACTURING Product Control	Production Managers	read, write	Production Control	Equipment Data Maintenance Schedule Providers Engineering Notes
	Production Control Staff	read, write		
	Operations Managers	auth: read		
	Finance & Accounting	auth: read		



## 2.4 Warehousing Process Decomposition

Warehouse management involves inventory storage and distribution of XYZ BFD procured and produced products. It includes three level 2 processes, summarized in Table 2.4.1.<sup>8</sup>

Warehousing/distribution processes are partially described in the XYZ BPR changes documentation, and detailed in the project ABC documentation.

**Table 2.4.1. Warehousing Process Level 2 Decomposition**

USERS	PROCESS	INFORMATION
Warehouse manager Warehouse staff Customers Other XYZ employees	Inventory Control	XYZ-owned and non-owned warehouse inventory databases and inventory audit files
Warehouse manager Warehouse staff Customers Finance and accounting staff	Shipping	POs, releases, returns, and transfer transactions Invoices XYZ-owned warehouse inventory databases
Warehouse manager Warehouse staff Customers Other XYZ employees Finance and accounting staff	Receiving	Invoices XYZ-owned warehouse inventory databases

The inventory control process maintains accurate type, location, and quantity of products stored in both XYZ-owned and non-owned databases, and responds to inquiries about inventory. For inventory stored in non-owned warehouses, XYZ may inquire about its inventory, but may not update the information in that database; update privilege is reserved to the owner of the database. The inventory control process has two level 3 processes, as summarized in Table 2.4.2.

**Table 2.4.2. Inventory Control Process Level 3 Decomposition**

USERS	PROCESS	INFORMATION
Warehouse manager Shipping & receiving staff	Inventory update process	XYZ-owned inventory databases
Warehouse manager Warehouse staff Customers Authorized XYZ employees	Inventory inquiry (linkage of inquiry process), XYZ internal use product inquiries Shipping/receiving location finding inquiries	XYZ-owned and non-owned inventory databases

<sup>8</sup> It is assumed that some XYZ-internal-use products are stored in warehouses as well as other XYZ facilities where these products (e.g., manufacturing raw materials, facilities management office supplies, and IS/Comm management operations supplies and backup/transition hardware) to be used are stored.

The inventory update process is used to maintain accurate type/location/quantity of warehouse-stored products. There are two related but different sub-processes associated with the inventory update process, summarized in Table 2.4.3.

**Table 2.4.3. Inventory Update Process Level 4 Decomposition**

<b>USERS</b>	<b>PROCESS</b>	<b>INFORMATION</b>
Warehouse manager Warehouse staff	Normal Operations Inventory Update	XYZ-owned inventory databases
Outside independent inventory audit team and/or Inside assigned inventory audit team	Inventory Audit	XYZ-owned inventory databases and inventory audit count and discrepancies database

The normal operations inventory update sub-process is utilized by the shipping and receiving processes which routinely “pick and put” warehouse inventory. This accomplishes their distribution and storage functions.

The inventory audit sub-process provides the checks and balances oversight function for warehouse inventory control. The inventory audit sub-process is used to maintain the integrity of the inventory control process. Inconsistencies found between the inventory control database and manual counting results are reviewed and reconciled. The database is then adjusted.

The inventory inquiry process decomposes to two different types of inquiry handling sub-processes. The first is a link from the Level 1 Inquiry process, described in Section 2.2. The second type of inquiry sub-process is specific to internal XYZ and XYZ BFD employee inventory database queries. The inventory inquiry sub-process decomposition is summarized in Table 2.4.4.

**Table 2.4.4. Inventory Inquiry Process Level 4 Decomposition**

<b>USERS</b>	<b>PROCESS</b>	<b>INFORMATION</b>
Potential Customers, Customers, XYZ Employees	Inquiry Process Linkage	Sold & to-sell product inventory databases in two major partitions.
Authorized XYZ Employees	XYZ-Employee-Only Inventory Inquiry process	All XYZ-owned inventory databases

The inquiry process linkage relates to two distinctly different inquiry sub-processes, as discussed in Section 2.2, and summarized in Table 2.2.3. The sub-processes are distinguished by inventory inquiry to the general products inventory, and inventory inquiry to a specific customer’s products inventory.

The XYZ-employee-only inquiry process is a separate sub-process of the warehouse inventory control process; it is not associated with the inquiry process described in Section 2.2. The

UNCLASSIFIED

purpose of this sub-process is to allow authorized XYZ employees to view inventory information related to XYZ BFD internal-use products stored in XYZ owned/managed warehouses. Authorized XYZ employees include staff from the manufacturing, facilities management, and IS/Comm management organizations.

The shipping process distributes products from warehouses to XYZ customers, XYZ internal organizations, and returns to suppliers. The shipping process is driven by four types of activities: customer purchase orders, customer releases, internal XYZ transfers, and supplier return orders. From these four driving activities, the shipping process collects the identified products from the warehouse inventory, packages the collected bundles for shipping, selects the appropriate carrier method, creates a shipping invoice, and ships the product bundles. The shipping process also includes notification messages to Finance & Accounting, other internal XYZ organizations, suppliers, and customers, as necessary, and updates the inventory databases via the inventory control update process. Table 2.4.5 summarizes the level 3 shipping process decomposition.

**Table 2.4.5. Shipping Process Level 3 Decomposition**

USERS	PROCESS	INFORMATION
Warehouse shipping staff, customers, authorized XYZ employees	Shipping Request Handling Process	Order files, supplier return messages from internal organizations, transfer messages from internal organizations, and pick/bundle files
Warehouse stock staff	Picking & Bundling Process	Pick/bundle files
Warehouse shipping staff	Invoice & Ship Process	Invoices, customer profiles, preferred freight carriers, notification messages

The shipping request handling process is activated by inputs from order processing, and XYZ internal transfer and supplier product return messages. This process creates stock pick & bundle files that direct warehousing stock handling personnel to fetch and package the appropriate product bundles for shipping.

The picking and bundling manual process fetches the stock items directed in a pick/bundle file and packages/bundles the collection of items for shipping.

The invoice and ship process checks the bundle ready for shipment against the purchase order, release, or return, making any adjustments necessary to ensure the purchase order or release is filled correctly or the return to supplier is complete in accordance with the receiving invoice. This process also creates an invoice for the goods to be shipped, ensures the goods are shipped by the appropriate carrier, and notifies the proper XYZ BFD organizations of the shipment. Also, this process updates the warehouse inventory databases to reflect the stock used.

The receiving process takes in supplier shipments and customer-returned goods to XYZ warehouses, and handles transfers between XYZ and non-XYZ controlled warehouses. This

process is essentially the reverse of the shipping process. Table 2.4.6 summarizes the level 3 decomposition of the receiving process.

**Table 2.4.6. Receiving Process Level 3 Decomposition**

USERS	PROCESS	INFORMATION
Warehouse receiving staff	Received Products Handling process	Supplier invoices, customer return goods invoices, XYZ internal transfer transactions
Stock movement staff	Stock Products Received	Inventory database(s)
Warehouse receiving staff	Received Goods Invoice Processing	Accounts payable invoice database, accounts receivable database adjustments (returned customer goods)

The received products handling process deals with deliveries to the warehouse. The process is responsible for checking the invoice against goods received, and logging the supplier invoice, customer returned goods invoice, or internal transfer transaction for processing. The stock products received process deals with storing the delivered goods in the warehouse and updating the inventory database(s). The received goods invoice processing process deals with archiving the receiving invoices and internal transfer transactions. It is also responsible for forwarding a copy of the invoice along with date received to the finance and accounting accounts payable process for supplier receiving goods, and accounts receivable process for customer returned goods. There are no level 4 receiving process decompositions.

## 2.4.1 Warehousing Process Threat Analysis & Information Domains

In analyzing the warehousing processes and information from a threat perspective, three general controlling functions are examined: inventory management, shipping and receiving transaction management, and warehousing oversight management.

From the XYZ Corporation Information Protection Policy:

### Warehousing/Distribution/Transport

**Threats:** Information about inventories of products, shipping schedules, carriers, transfers and disposals is threatened by loss or damage (low) but has (significant) impact on service to customers.

**Security Services:** This information is in access (moderate) to authenticated (minimum) customers, and XYZ employees. Integrity (moderate) in storage and transfer and confidentiality (minimum) in transfer is required.

The threat analysis conclusions of XYZ BFD's warehousing information varies somewhat from the corporate-level IPP threat conclusions, as follows.

**UNCLASSIFIED**

1. Inventory management includes managing privileges to update the inventory database(s) by particular users. The threat of unauthorized modification (loss or damage) is *medium* and has a *significant* impact potential on service to customers, but only a *minimum* impact potential of product/property theft. The non-availability threat to inventory information is *low* but has a *significant* impact potential on service to customers.<sup>9</sup>
2. Shipping and receiving transaction management includes pulling/picking and putting stock distribution operations, and managing invoices, releases, and transfer transaction handling and notification processes and procedures. The threat of unauthorized disclosure is *low* and has a *minimum* impact. The threat of unauthorized modification is *medium* and could have a *significant* impact.
3. Warehousing oversight management is fulfilled with the Inventory Audit process. The audit process includes independent physical stock counts to match against the inventory database, discrepancies records, and investigative results information. The threat of unauthorized disclosure is *low* and has a *minimum* impact. The threat of unauthorized modification is *medium* and could have a *serious* impact.

Considering the above threat conclusions to warehousing information, seven information domains for the XYZ BFD warehousing process are determined. Two of the seven have been defined in Section 2.2 - the status and inventory and inventory and quotes inquiry process domains. The remaining five information domains are summarized in Table 2.4.7.

**Table 2.4.7. Warehousing Process Information Domains**

<b>DOMAIN</b>	<b>USERS</b>	<b>RULES</b>	<b>PROCESS</b>	<b>INFORMATION</b>
WRHS Internal Products Inv. Management	Manufacturing staff	Auth: read	Internal-Use- Products Inventory Inquiry	Internal-use- products inventory
	Facilities mgt staff	Auth: read		
	IS/ Comm mgt staff	Auth: read		
	Warehouse employees	Auth: read/write	Inventory Update proc	
WRHS Customer- Specific Prod Inventory Management [1per cust acct]	Customer rep(s)	Auth: read	Inquiry process	Customer- specific inventory
	Account manager	Auth: read		
	Account/Sales rep	Auth: read		
	Warehouse employees	Auth: read/write	Inventory Update process	
WRHS General Prod Inventory Management	Anyone	Auth: read	Inquiry process	General products inventory
	Warehouse employees	Auth: read/write	Inventory Update process	

<sup>9</sup> The non-availability threat correlation to the unauthorized modification threat (i.e., destruction of inventory information) carries the same potential and impact to customer service as defined by the unauthorized modification threat.

DOMAIN	USERS	RULES	PROCESS	INFORMATION
WRHS Accounting Management	Warehouse employees	Auth: read & write	Warehouse Management	Invoice logs & archive, transfer & return transactions notification info
WRHS Inventory Audit Management	Independent audit personnel and authorized warehouse employees	Auth: read & write	Inventory Audit process	Inventory audit count, discrepancies, and investigative files

## 2.5 Business Planning Process Decomposition

The business planning process focuses upon the plans and strategies to support U.S. Business Form’s missions. The Business Planning Process develops the business directives, objectives, and goals and determines the critical success factors for the corporation. Information is retrieved from sales, budgeting, marketing, and manufacturing. The business planning process in Table 2.0.1 does not decompose below level 1. Table 2.5.1 shows level 1 with a detailed breakout of the users and information. This analysis was guided by the NorthStar documentation and interviews with XYZ executives.

**Table 2.5.1. Business Planning Process Level 1 Decomposition**

Users	Process	Information
XYZ BFD executives and staff	Business planning	Strategic targets, policies, directives, objectives, goals
Sales managers		
Manufacturing managers		
Finance managers		

### 2.5.1 Business Planning Process Threat Analysis and Information Domains

From the XYZ Corporation Information Protection Policy—

## Planning

**Threats:** Information about planning for new products, new business areas, facility and equipment additions or modification, price changes, strategic account management, research, marketing initiatives is threatened by disclosure (low) but can have (significant) impacts through competitor knowledge.

**Security Services:** Access (moderate) to such information is to specifically involved XYZ personnel with confidentiality (moderate) and integrity (minimum) in storage and transfer. Sales personnel are permitted to release information to customers at planned release dates or events. This represents a change in policy for that information which is to be effected by the designated security administrators.

The business planning process has a single information domain. XYZ is concerned both with the integrity and confidentiality of this information. Access to this information is to managers and executives and their staffs. To protect the integrity of this information only the executives and their staffs can enter or write the information. To generate this information the executives and their staffs must be members of other domains to read whatever information they need. This information includes competitors prices, sales planning, sale budgets, market research, manufacturing plans, etc. The Business Planning domain is shown in Table 2.5.2.

**Table 2.5.2. Business Planning Process Information Domains**

DOMAIN	USERS	RULES	PROCESS	INFORMATION
BUSINESS PLANNING	XYZ BFD executives and staff	Read/write	Business Planning	Strategic targets, policies, directives, objectives, goals
	Sales managers	Read		
	Manufacturing managers	Auth: read		
	Finance managers	Auth: read		

## 2.6 Marketing Process Decomposition

The marketing process from Table 2.0.1 is decomposed into product promotion, targeting/projections management, and sales analysis as shown in Table 2.6.1. The decomposition was guided by existing mainframe applications, the NorthStar Project documentation, and XYZ BPR changes concepts.

**Table 2.6.1. Marketing Process Level 2 Decomposition**

<b>USERS</b>	<b>PROCESS</b>	<b>INFORMATION</b>
Potential customers, customers, sales managers, sales representatives	Product Promotion	Catalog, brochures, advertisements, standard prices
Sales managers sales representatives XYZ BFD executives	Targeting/ Projections Management	Customer histories, customer pricing strategic targets, monthly/yearly projections, market research, competitor prices, sales planning
Sales managers sales representatives XYZ BFD executives	Sales Analysis	Sales performance monitoring scorecards

## 2.6.1 Marketing Process Threat Analysis and Information Domains

From the XYZ Corporation Information Protection Policy:

### Marketing

**Threats:** Marketing information wherein sales people promote products and service to customers and potential customers, assess markets, quote standard pricing, and acquire information about the competition is threatened (medium) by the possibility of information being lost or damaged. The impact of such loss is considered (mild) requiring an investment in the rebuilding of the information.

**Security Services:** Marketing information shall be protected for data integrity (minimum). Confidentiality is not required. Access controls (minimum) must limit information entry to XYZ personnel with some exceptions for customer inquiry records.

### Sales

**Threats:** Sales information wherein non-standard pricing arrangements are afforded to specific customers, or planning for special sales or agreements is threatened by disclosure (medium) and loss or damage (medium). The impact of disclosure is (significant) and of loss or damage is (mild)



## UNCLASSIFIED

Appendix H, Annex A  
IATF Release 3.1—September 2002

**Security Services:** This sales information requires confidentiality (minimum) and integrity (minimum) in both storage and transfer. Access control (minimum) must limit information entry and disclosure to XYZ sales personnel and information disclosure to only the specific customers involved. I&A (minimum) is required to support the other security services.

Analysis of the information and users of marketing at the second level of decomposition resulted in a perceived need to separate customer unique information into marketing-customers domains. This limits access to a customer's history and any special pricing to those with specific customer responsibilities or oversight positions. The customer's sales representative is therefore granted read and write access in this domain. The sales analyst here is considered an oversight role with equal privileges. The specific customer is granted read access. Other customers and sales representatives are excluded. The process called upon in this domain, profile management, is drawn from the customer ordering process. The separation of customer history from customer pricing was considered as a possible need but is not recommended as necessary. Sales Managers are authorized read access for administrative oversight of marketing.

The marketing-promotion domain allows practically anyone to view all the products and services available from XYZ BFD. This domain is for advertising and must be widely viewable. The content however must be generated and controlled by XYZ BFD marketing. The preparation of this information is accomplished by Sales Managers and Sales Analysts.

The Marketing-Strategy domain is viewable by XYZ BFD management and marketing personnel. Customers and other users are excluded to protect the timing and objectives of major sales events until available to the public. At the appropriate time, sales managers and analysts may transfer information from the marketing-strategy to the marketing-promotion domain. This domain also includes information gathered about competitors and any marketing plans. The documentation of marketing-strategy information is accomplished by Sales Analysts.

The marketing-sales domains (one per customer) permits the customer's sales representative to see performance data for his or her accounts but excludes other sales representatives. Managers and XYZ BFD executives can monitor this activity but only Sales Analysts may prepare the information.

Any of the privileges identified within these Marketing information domains must be enabled by the authentication of the identities claimed.

**Table 2.6.2. Marketing Process Information Domains**

DOMAIN	USERS	RULES	PROCESS	INFORMATION
MKTNG Promotion	Potential customers	Read	Product Promotion	Catalog, brochures, advertisements, standard prices
	Customers (any)	Read		
	Sales managers (any)	Read, Auth: write		
	Sales analysts (any)	Read, Auth: write		
	Sales representatives (any)	Read		
	XYZ BFD executives	Read		
MKTNG Customer  (one per customer)	Customers (specific)	Auth: read	Profile Management	Customer histories Customer pricing
	Sales managers (any)	Auth: read		
	Sales analyst (any)	Auth: read, Auth: write		
	Sales representatives (Customer's)	Auth: read, Auth: write		
MKTNG Strategy	Sales managers (any)	Auth: read, Auth: write	Targeting/ Projections Management	Strategic targets, Competitor prices, sales planning Monthly/yearly projections, market research
	Sales analysts (any)	Auth: read, Auth: write		
	Sales representatives (any)	Auth: read		
	XYZ BFD executives	Auth: read		
MKTNG Sales  (one per customer)	Sales managers (any)	Auth: read	Sales analysis	Sales performance monitoring scorecards
	Sales analysts (any)	Auth: read, Auth: write		
	XYZ BFD executives	Auth: read		
	Sales representatives (specific customer)	Auth: read		

## 2.7 Finance and Accounting Process Decomposition

The finance and accounting process from Table 2.0.1 is decomposed into Accounts Receivable, Accounts Payable, and General Ledger as shown in Table 2.7.1.

**Table 2.7.1. Finance and Accounting Process Level 2 Decomposition**

USERS	PROCESS	INFORMATION
Finance managers Accounts receivable staff	Accounts receivable	Customer information customer orders warehouse, manufacturing info credit info prices collections general ledger
Finance managers Accounts payable staff	Accounts payable	Warehouse, manufacturing info facilities info, invoices customer orders payments, on-hold payments contracts general ledger payroll
Finance managers Plans staff	Financial planning	Pricing general ledger investment records tax records, payroll records customer profiles reports assets budgets capital expenditures

## 2.7.1 Finance and Accounting Process Threat Analysis and Information Domains

From the XYZ Corporation Information Protection Policy—

### Finance and Accounting

**Threats:** Financial information such as customer accounts receivable, accounts payable, general ledgers, financial reports, purchase orders, banking, payroll, commissions and bonuses, capital expenditures, and capital assets are considered to be threatened by disclosure (high) and loss or damage (medium). The impact of disclosure is (serious) and of loss or damage is (significant).

**Security Services:** This information is in access (strong) to specific finance personnel by information domain, to all auditors and XYZ business area and corporate officers as needed. Confidentiality (strong) and integrity (moderate) in storage and transfer is required. I&A required is (strong)

The information domains shown in Table 2.7.2 were chosen to separate planning from transactional information, and internal transactions from external transactions. This separation allows information to be entered by XYZ employees other than finance and accounting. This is in variance to the limitations imposed by XYZ Corporate policy but is necessary for business flow. The domain structure chosen would require accounts receivable and accounts payable to be transferred into the general ledger by financial personnel.

Similarly, warehouse, manufacturing, and facilities transactions can be recorded by those staffs with finance controlling posting to the ledger.

**Table 2.7.2. Finance and Accounting Process Information Domains**

DOMAIN	USERS	RULES	PROCESS	INFORMATION
FINANCE Management	Finance managers	Read, write	Financial Planning	Assets, budgets tax records general ledger capital expenditures reports investments banking
	Finance staff	Read, write		
	XYZ BFD executives	Auth: read		
	Auditors	Auth: read		
			Accounts payable	
			Accounts receivable	
FINANCE Customer  (one/customer)	Accounts receivable staff	Read, write	Accounts receivable	Customer credit customer orders special pricing collections
	Finance managers	Auth: read		
	Sales managers	Auth: read		
	Sales representatives (specific customer)	Auth: read		
FINANCE Deliveries	Accounts receivable staff	Read, write	Accounts receivable	Warehouse invoices manufacturing invoices Contract deliveries
	Finance managers	Read, write		
	Warehouse staff	Read, write		
	Manufacturing staff	Read, write		
FINANCE Expenditures	Accounts payable staff	Read, write	Accounts payable	Warehouse expen Mfg/facilities expen is/comm expen payments, On Hold contracts let
	Warehouse staff	Read, write		
	Manufacturing staff	Read, write		
	Facilities staff	Read, write		
	IS/Comm staff			
FINANCE Payroll	Accounts payable staff	Read, write	Payroll	Employee records EFT transfers commissions bonuses
	HR personnel	Auth: read		

## 2.8 Personnel Management Process Decomposition

The personnel management process manages all actions associated with XYZ employees, including payroll. The process from Table 2.0.1 is decomposed into H/R management, employee records management, and payroll management as shown in Table 2.8.1.

**Table 2.8.1. Personnel Management Process Level 2 Decomposition**

USERS	PROCESS	INFORMATION
Employees	Personnel Management	Organizational
H/R Personnel		Training Information
Finance Personnel		Recruiting
U.S. Business Form's Execs		Benefits & Compensation
		Division Policy & Procedures
Employees	Employee Records Management	Employee
H/R Personnel	Payroll Management	Time & Attendance
Finance Personnel		

### 2.8.1 Personnel Management Process Threat Analysis and Information Domains

From the XYZ Corporation Information Protection Policy:

#### Human Resources/Personnel Administration

**Threats:** Information about XYZ personnel which permits the administration of payroll and benefits, promotions, assignment of duties, and performance appraisals, is considered threatened by disclosure (medium) and by loss or damage. The impact of disclosure to anyone who does not specifically need to know is (serious). The impact of loss or damage is (significant).

**Security Services:** Access to this information must be (strong) to only those involved in personnel administration and to the specifically involved supervisory personnel. Confidentiality (strong) and integrity (strong) is required for storage and transfer of this information. I&A (strong) is necessary to support the other security.

#### Finance and Accounting

**Threats:** Financial information such as customer accounts receivable, accounts payable, general ledgers, financial reports, purchase orders, banking, payroll, commissions and bonuses, capital

expenditures, and capital assets are considered to be threatened by disclosure (high) and loss or damage (medium). The impact of disclosure is (serious) and of loss or damage is (significant).

**Security Services:** This information is in access (strong) to specific finance personnel by information domain, to all auditors and XYZ business area and corporate officers as needed. Confidentiality (strong) and integrity (moderate) in storage and transfer is required. I&A required is (strong).

Analysis of this information, which contains both human resources and financial information, results in the need to separate employee-unique information from general personnel information. Further access to and the ability to create or change employee-unique information must be tightly controlled. This leads controlled access to the information and to the separation of employee information into information that the employee can create or change and employee information that only an employee can read. Each of these domains have two processes that can act upon the information. Only employees and H/R personnel can use the Manage Employee records process. Only finance personnel can use the payroll process. These two domains are called employee managed records/payroll and employee-h/r managed domains, respectively. Analysis of the general personnel information leads to the need to protect the integrity of the information. This leads to the separation of this information into domains were only the H/R personnel and the Division executives can create or change the information. These domains are the h/r management and division policy domains. These domains are shown in Table 2.8.2.

**Table 2.8.2. Personnel Management Process Information Domains**

DOMAIN	USERS	RULES	PROCESS	INFORMATION
PERSONNEL Employee-Managed Records/Payroll	Employee (specific)	Read/write	Manage Employee Records	Employee managed
	H/R personnel	Read/write	Payroll processing	Time & attendance
	Finance personnel	Auth: read		
PERSONNEL Employee-H/R Managed	Employee (specific)	Auth: read	Manage Employee Records	H/R managed
	H/R personnel	Auth: read/write	Payroll processing	
	Finance personnel	Auth: read		
PERSONNEL H/R management	Employees (any)	Auth: read	H/R Management	Organizational
	H/R personnel	Read/write		Training programs
	Finance personnel	Auth: read		Recruiting
PERSONNEL Division Policy	XYZ BFD execs	Read/write	Policy Management	Division policy & procedures
	Employees (any)	Auth: read		

## 2.9 Information Systems & Communications Management Process Decomposition

The IS/Communications management process operates, monitors, and maintains XYZ BFD electronic information management technologies and applications. It is also responsible for planning, transitioning, integrating, testing, and administering new information systems and applications to maintain a technologically competitive work flow environment for XYZ BFD's business processes, customers, and employees. This process decomposes to four level 2 sub-processes, summarized in Table 2.9.1.

**Table 2.9.1. IS/Comm Management Process Level 2 Decomposition**

<b>USERS</b>	<b>PROCESS</b>	<b>INFORMATION</b>
IS/Comm operations staff	Operations	System management Information network management information
IS/Comm management & planning staff, outside contractors and consultants	Planning	Planning information
Integration contractors, IS/Comm management staff	Integration & Test	Integration information, test and evaluation information
Outsourcing contract manager IS/Comm management staff	Outsource contractor oversight	Contract information, performance information, financial information, adjustments information

The operations process decomposes to two level 3 sub-processes, summarized in Table 2.9.2.

**Table 2.9.2. Operations Process Level 3 Decomposition**

<b>USERS</b>	<b>PROCESS</b>	<b>INFORMATION</b>
IS/Comm managers end-system system operators end-system users capital equipment administrators IS Help desk personnel system hardware/software maintenance personnel application server O&M staff	System management	Capital Equipment inventory configuration information accounting information performance information trouble reporting/resolution information scheduling information outage & status information application management info
IS/Comm managers tech controllers end-system users capital equipment administrators Comm help desk personnel Comm hardware/software maintenance personnel	Network management	Capital Equipment inventory configuration information accounting information performance information trouble reporting/resolution information status & outage information

The system management process deals with the operations and maintenance of all XYZ BFD end systems. End systems include all workstations, laptops/notebooks, terminals, mainframes, mini and micro servers, telephones, facsimile equipment, and video conferencing cameras, computers, etc. used for information processing and information exchange in XYZ BFD'S area of IS/Comm management. It also includes all applications, system software, and utilities used on those end systems, as applicable. It does not include manufacturing equipment; manufacturing equipment used to produce XYZ BFD products is the responsibility of the manufacturing management process. The system management process decomposes to seven level 4 sub-processes, summarized in Table 2.9.3.

**Table 2.9.3. System Management Process Level 4 Decomposition**

<b>USERS</b>	<b>PROCESS</b>	<b>INFORMATION</b>
IS/Comm managers capital equipment administrator	Capital Equipment Inventory Management	Capital equipment inventory
IS/Comm managers system operators	Configuration Management	Configuration information
IS/Comm managers system operators end system users	Accounting Management	Accounting information
IS/Comm managers system operators	Performance Management	Performance monitoring information



**UNCLASSIFIED**

Appendix H, Annex A  
IATF Release 3.1—September 2002

<b>USERS</b>	<b>PROCESS</b>	<b>INFORMATION</b>
IS/Comm managers system operators	Job/scheduling Management	Job/scheduling information
IS/Comm managers IS help desk personnel system operators system hardware/software maintenance personnel end system users	Trouble Reporting & Resolution Management	Trouble reports/resolution information
IS/Comm managers system operators	Outage Collection Management	System outage & recovery information
IS/Comm managers application server O&M staff	Application Management	Application configuration & utilization information

The network management process deals with the operations and maintenance of all XYZ BFD’s communications systems, which includes: local area network media, hubs, bridges, and routers/gateways and configuration and addressing tables; local plant telephone wiring and switching components, and wide area communications leased line services and value added network interfaces from XYZ BFD facilities. The network management process decomposes to eight level 4 sub-processes, summarized in Table 2.9.4.

**Table 2.9.4. Network Management Process Level 4 Decomposition**

<b>USERS</b>	<b>PROCESS</b>	<b>INFORMATION</b>
IS/Comm managers capital equipment administrator	Capital Equipment Inventory Management	Capital equipment inventory
IS/Comm managers comm operators	Configuration Management	Configuration information
IS/Comm managers comm operators end system users	Accounting Management	Accounting/utilization information
IS/Comm managers comm operators	Performance Management	Performance monitoring information
IS/Comm managers Comm help desk personnel Comm operators Comm system hardware/software maintenance personnel end system users	Trouble Reporting & Resolution Management	Trouble reports/resolution information
IS/Comm managers comm operators	Outage Collection Management	Comm outage, recovery, & status information

Based on design and personnel allocation considerations, the system and network processes could be combined, but with clear delineation of roles and responsibilities. Common sub-processes, such as capital equipment inventory management, trouble reporting and resolution management, and to some extent configuration management, are logical candidates of overlapping functions where certain personnel may play both the system and network management roles.

Power, air conditioning, etc. required for IS/Comm is the responsibility of the facilities management process. Security management required for IS/Comm and facilities is the responsibility of the security management process.<sup>10</sup> Although it is necessary to delineate these processes in this way, it is possible that personnel roles and responsibilities may overlap organizational structure delineations. The latter is both a system design and personnel allocation consideration. In the case of security management, it is also a crucial security consideration—internal XYZ personnel should always be the security managers and administrators.

The IS/Comm planning process includes change management, system transitions, and the analysis of its information management model, new standards, technologies, and applications that XYZ BFD could utilize to maintain a competitive information management posture in the forms marketplace. This process does not decompose further, unless IS/Comm management chooses to detail it to a finer granularity, depending on the scope of its planning activities.

The integration and testing process includes system design, integration planning, and operational test and evaluation activities necessary to fulfill the results of planning process activities. This process also includes ordering hardware and software components from chosen vendors, and managing warehouse transfer requests to move warehouse-stored products for integration and testing. This process does not decompose further, unless IS/Comm management decides to detail it to a finer granularity, depending on the scope of any integration and testing activities. There is close coordination between the operations, planning, and integration and testing processes to ensure continuing operational performance objectives.

The outsource contracting management process includes managing the outsource contracts, providing outsource contractor direction and guidance, and rating the outsource contractor performance. This process does not decompose further, unless IS/Comm management determines that each of the functions need to be delineated to a finer granularity. There is obvious need for coordination between system, network, and integration/test performance monitoring functions and the outsource contracting management process.

---

<sup>10</sup> Security management architectural constructs typically spread across facilities management (the environment protection allocations), end systems (the information system protection portion of IS/Comm), and communication systems (the transfer system portion of IS/Comm). Although an autonomous and independent level 1 process, security management blankets integral portions of all core and infrastructure business processes.

## 2.9.1 IS/Comm Process Threat Analysis & Information Domains

Threat analysis of XYZ BFD IS/Comm process and sub-processes concludes no variance from the threat analysis results of this infrastructural area described in the XYZ Corporate-level Information Protection Policy.

From the XYZ Corporation Information Protection Policy:

XYZ sets high standards in service and product availability to its customers. Information systems are threatened by:

- Processing system failures: malfunctions, errors, deliberate destruction, inadequate performance
- Communications system failures: malfunction, errors, deliberate destruction, inadequate performance
- Application failures: errors, loss, corruption
- Information failure: errors, loss, corruption, spoofing

The probability of one or more of these events occurring is (high) and will result in the disclosure, loss, or damage to information. The impacts are (serious).

As a result of these threats, their potential, and impact, eleven information domains have been generated. These information domains are summarized in Table 2.9.5.

**Table 2.9.5. IS/Comm Management Process Information Domains**

DOMAIN	USERS	RULES	PROCESS	INFORMATION
IS/COMM Management	Managers	Auth: read/write	Configuration mgmt Performance mgmt Outage Collect mgmt Accounting mgmt Scheduling mgmt	Configuration performance system outage, recovery & status accounting scheduling
	Operators	Auth: read/write		
	Users	Auth: read		
IS/COMM Maintenance	Managers	Auth: read	Trouble Reporting/Resolution mgmt	Trouble reports/resolution database
	Help desk staff	Auth: read/write		
	Operators	Auth: read/write		
	Maintenance staff	Auth: read/write		
	Users	Auth: read		
	Application staff	Auth: read/write		

**UNCLASSIFIED**

<b>DOMAIN</b>	<b>USERS</b>	<b>RULES</b>	<b>PROCESS</b>	<b>INFORMATION</b>
IS/COMM Trouble reporting	Help desk staff	Auth: read/ write	Trouble Report Submission	Trouble report entries
	Operators	Write		
	Users	Write		
	Application staff	Write		
IS/COMM Applications	Managers	Auth: read	Application mgmt	Application configuration/utilization
	Application staff	Auth: read/write		
IS/COMM Management	Managers	Auth: read/write	Configuration mgmt Performance mgmt Outage Collection mgmt Accounting mgmt	Configuration performance system outage, recovery/status accounting
	Operators	Auth: read/write		
	Users	Auth: read		
IS/COMM Maintenance	Managers	Auth: read	Trouble Reporting & Resolution mgmt	Trouble reports/ resolution database
	Help desk staff	Auth: read/write		
	Operators	Auth: read/write		
	Maint. personnel	Auth: read/write		
	End system users	Auth: read		
	Appl O&M staff	Auth: read/write		
IS/COMM Trouble reporting	Help desk staff	Auth: read/ write	Trouble Report Submission	Trouble Report Entry Information
	Operators	Write		
	Users	Write		
	Application staff	Write		
IS/COMM Inventory	Managers	Auth: read	Capital Equipment Inventory mgmt.	Capital Equipment Inventory
	Capital equipment administrator	Auth: read/write		
IS/COMM Planning	Managers	Auth: read/write	Planning	Plans
	Planning staff	Auth: read/write		
	Contractors	Auth: read/write		
	Consultants	Auth: read		
	Employees	Auth: read		
IS/COMM Integration	Contractors	Auth: read/write	Integration/Test	Integration Test/Evaluation
	Management	Auth: read/write		
IS/COMM Contracts	Outsource Management	Auth: read/write	Outsource Contract Oversight	Contract, performance, financial, and adjustments
	Management	Auth: read/write		

## 2.10 Facilities Management Process Decomposition

Facilities management deals with two major infrastructure support elements of XYZ BFD: office supplies management, and physical facilities and utilities management and maintenance.

**Table 2.10.1. Facilities Management Process Level 2 Decomposition**

USERS	PROCESS	INFORMATION
Office managers, admin staff	Office Supplies Management	Ordering Information (POs) delivery Information (Invoice) transfer Information inventory Information utilization statistical Info
Facility managers, maintenance staff	Physical Facilities & Utilities Management	Facility incident reports personnel locator list utilities utilization & outage logs utilities maintenance reports ordering information (POs) delivery Information (Invoice) billing (AP) Information transfer information inventory information

Although it is possible to decompose each of the two processes to lower levels of resolution, it is not necessary from a security perspective.

### 2.10.1 Facilities Management Process Threat Analysis and Information Domains

From the XYZ Corporation Information Protection Policy:

#### Facilities Management

**Threats:** Facilities management information when associated with the security management function is threatened by loss or damage (medium). The reliability of electrical power systems, air conditioning, communications channels is a security issue. Information about power systems service providers and product repair services are examples of relevant data.

**Security Services:** Data integrity (minimum) of facilities management data must be maintained.

Two information domain types are determined to maintain the separation of office supplies and physical facilities management. The office supplies management domain type may be a single domain for the entire facility, or it may be separate domains by division. The physical facilities management domain type has at least one information domain type of this kind per XYZ BFD facility. Small satellite facilities may be under a single domain, or arranged by region and coupled with larger facilities in that region. The two domain types are summarized in Table 2.10.2.

**Table 2.10.2. Facilities Management Process Information Domains**

DOMAIN	USERS	RULES	PROCESS	INFORMATION
FACILITIES MGMT Office supplies	Office managers	Auth: read/write	Office Supplies mgmt	Ordering (POs) delivery (invoice) transfer inventory utilization statistics
	Administrative staff	Auth: read/write		
FACILITIES MGMT Facilities and Utilities	Facility managers	Auth: read/write	Physical Facilities/ Utilities mgmt	Facility incident reports personnel locator list utilities utilization/outage logs utilities maintenance reports ordering (POs) delivery (invoice) billing (AP) transfer inventory
	Maintenance staff	Auth: read/write		

## 2.11 Corporate Relations Process Decomposition

The corporate relations process is focused upon report information and does not decompose below the first level.

### 2.11.1 Corporate Relations Process Threat Analysis and Information Domains

From the XYZ Corporation information protection policy:

## XYZ Corporate Relations

**Threats:** Information exchange between corporate divisions of XYZ are threatened by loss or damage (low). The impact of such a loss is (mild).

**Security Services:** Access (minimum) to this information should be to XYZ Employees. Data integrity requirements are (minimum).

There are minimal requirements for protection on the corporate relations information. However, there is still a need to protect the integrity of the information which is reflected in the rules. The domain for this process is shown in Table 2.11.1.

**Table 2.11.1 Corporate Relations Process Information Domain**

DOMAINS	USERS	RULES	PROCESS	INFORMATION
Corporate Relations	XYZ BFD Execs	auth: read/write	Corporate Relations	Reporting Information
	Corporate Executives	auth: read		

## 2.12 Security Management Process Decomposition

Security management deals with the initialization and subsequent operational controls of security policy (or policies) and security mechanisms. It is a process which is interleaved throughout and supports all information domains, and, as part of a security architecture, is allocated across environmental, end system, and transfer system architectural elements. As a logical process portion of the information management model, it decomposes to two level 2 processes, summarized in Table 2.12.1.

**Table 2.12.1. Security Management Process Level 2 Decomposition**

USERS	PROCESS	INFORMATION
Security Mgrs, Admin information domain members	Security Policy Management	Domain registration information security management information base
Security managers admin	Security Mechanism Management	Security management information base

The security policy management process deals with information management in both written form and machinable form. The written form includes XYZ corporation policies. In machinable form, this process installs and maintains rules and attributes to support the rules defined by the

written XYZ division IPPs. This process also registers information domains into the system and deletes information domains from the system.

The security mechanisms management process deals with the management of the security mechanisms and the information used by the security mechanisms to provide their security decision and enforcement functions. The security mechanisms enforce the security policy rules installed and maintained by the security policy management process. Each and every security mechanism implemented into the information system needs to be managed. Security mechanisms can be doctrinal, such as physical and procedural security, or electronic. Electronic security mechanisms always require doctrinal security mechanisms to protect them from unauthorized tampering, bypass, or destruction. Electronic security mechanisms include such things as user authentication, access control decision and enforcement functions, communication confidentiality, data integrity, and non-repudiation mechanisms (cryptographic mechanisms, key management mechanisms, digital signature mechanisms), and pervasive security mechanisms. The management of security mechanisms is a very complex process.

## 2.12.1 Security Management Process Threat Analysis & Information Domains

From the XYZ Corporation Information Protection Policy:

### Security Management

**Threats:** Implementation of policies and information needed to support the security services are at the core of any possibilities for information protection. Threats of disclosure and loss or damage are (high) and the impacts are (serious). Security management also involves physical security, administrative security, personnel security as well as the technical aspects of information security.

**Security Services:** This information requires integrity (strong) and confidentiality (strong) in storage and in transfer. Access control (strong) and the supporting I&A (strong) for specific security managers is required.

Every internal XYZ BFD information system component must have at least one context of a security management process and a security management information base. The security management process may be an integral element of the information domain of the user, or it may be a separate security management domain which is used to maintain and enforce the security policy for each, or all, information domains in which a user is authorized.<sup>11</sup> The security management domains are summarized in Table 2.12.2.

---

<sup>11</sup> There is one information domain in XYZ BF that anyone (identity unknown) may operate in -- the I1 inquiry process domain. The only security management function which is affiliated with this domain is the access control function to



**Table 2.12.2. Security Management Process Information Domains**

DOMAIN	USERS	RULES	PROCESS	INFORMATION
SECURITY MGMT System	Division security Mgr	Auth: read	Security Mgt	System security data
	System security Mgr	Read: write		
	Domain security Mgrs	Auth: read		
	Domain members	Auth: read		
SECURITY MGMT Mechanisms	Division security Mgr	Auth: read	Security Mgt	Security mechanisms data
	System security Mgr	Read: write		
	Domain security Mgrs	Auth: read		
	Domain members	Auth: read		
SECURITY MGMT Domain	Division security Mgr	Auth: read	Security Mgt	Domain security data
	System security Mgr	Auth: read		
	Domain security Mgrs	Read: write		
	Domain members	Auth: read		

### 3.0 Other Information Domain Considerations

Although unconfirmed, it is assumed that other types of information domains might be needed within XYZ BFD information systems. These other types of domains are compelled by the notion of individual employee domains, groupware domains for sharing correspondence between offices which do not, for one reason or another, fit a particular core or infrastructure business process defined in section 2, and perhaps others, such as “web server” (unauthenticated read only) domains, and the public domain. Architectural experiments currently underway within XYZ BFD, such as those investigating Internet-Commerce, groupware applications, etc. will require examination for new information domain considerations on a case by case basis. This stresses the importance of making XYZ BFD’s IMM and protection policies “living documents” -- i.e., they need to be upgraded from time to time, and maintained in accordance with changes in the IMM, XYZ BFD information protection policy, and XYZ Corporate Level information protection policy and policy guidelines.

---

maintain separation from all other information domains. All users of the I1 domain have read (non-authenticated read) privilege only.

# **PNE Annex B: Corporate IPP**

---

[This annex to this document is an unedited (except for company name) example of an actual IPP.]

## **XYZ CORPORATION**

### **Corporate Information Protection Policy**

**UNCLASSIFIED**

Appendix H, Annex B  
IATF Release 3.1—September 2002

**This page intentionally left blank**

# 1.0 Introduction

## 1.1 Purpose

This document establishes the policy of XYZ Corporation for the protection of information which is generated, stored, or received in the process of conducting its business. It presents the corporate policy on information protection in general as well as individual policies for specifically identified categories of information. Protection is defined for each information category in terms of the specific security services and the strengths required.

This document also establishes the procedures for its own maintenance and for the preparation and maintenance of other derivative policies for individual information categories.

## 1.2 Definitions

**Information:** data elements or objects generated, transferred, stored, processed, and destroyed in the conduct of business functions.

**Users:** individuals or groups of people who are responsible for managing a portion of the business information. Users include those who employ or manage information systems.

**Processes:** the functions performed by users or users aided by information systems which generate, transform, modify, collect, organize, present, and destroy information.

**Information Management Model (IMM):** a logical description of information management which depicts the users, processes, databases, and information flows which support a business enterprise.

**Information Domain:** A security entity composed of three elements—

- 1) Identifiable information objects.
- 2) membership of identifiable users
- 3) a security policy which defines the relationships between each member and all of the information objects.

**Information Domain Member:** a user identified to have some responsibilities or privileges in the management of the objects of an information domain.

**Security Policy:** rules which govern and identify the relationships between members and the objects of an information domain.

**Security Services:** activities that assist in, or provide for, the protection of information. Security services are provided by security mechanisms. Security mechanisms are diverse and include such things as guards, fences, cryptographic software, badges, or labels. The security

## UNCLASSIFIED

Appendix H, Annex B  
IATF Release 3.1—September 2002

services defined here are mutually supporting and often overlapping in the services provided. Although the definitions are provided in terms of people as individuals, they apply to groups, processes, and other agents or objects.

**Identification and Authentication (I&A):** The service which protects against the claims of individuals to be someone they are not. Identification is the establishment of the unique identity of an individual, group, or information system component. Authentication is the means for verifying the claimed identity.

**Access Control:** The service which protects information through the control of authorizations of individuals for knowledge or rights of manipulation.

**Confidentiality:** The service that protects information from knowledge or disclosure.

**Integrity:** The service that protects information from modification or loss.

**Availability:** The service that protects the individual from accidental or deliberate denial of access to information and other services.

**Non-repudiation:** The service which provides protection from an individual denying sending information (non-repudiation with proof of origin), or protection from an individual denying receiving information (non-repudiation with proof of delivery). These services are closely related to signing and notarization.

## 2.0 Information Protection Policy

### 2.1 Overview

The protection of information which supports business has always been essential to the success of corporations. However, many of the mechanisms for protection in computer based systems are significantly different from that of paper based systems. Ready access to information is one of the chief benefits of computer networks but it is also a major source of vulnerabilities. We take for granted the protective effects of buildings, offices, doors, receptionists, file cabinets, sealed envelopes, etc. Computer networks are designed for the sharing of information; overcoming distances and physical barriers that separate. Achieving a satisfactory balance between needed access and adequate protection requires the attention and careful consideration of the entire corporation. Security policies are instruments for coordination and agreement on what information needs protection, who are the potential adversaries, and who are the owners and protectors. Security policies document the decisions on protection and guide the architectures and implementations of information management systems.

XYZ Corporation mandates high availability of services to its customers. The provision of these services involves the access to some corporate information by XYZ's customers and even joint

management of other information by XYZ and its customers. Like most corporations, information is at the core of XYZ's business. There are many categories of information with different kinds and sources of threats. It is important to recognize that information protection is a direct service to customers as well as to XYZ's resources to provide all services. This policy presents the decisions and guidance for the necessary safekeeping of XYZ information.

## 2.2 Applicability

This security policy applies to all divisions of XYZ Corporation. As a multinational business XYZ is subject to the laws of the individual government jurisdictions. Conflicts which may arise between this policy and national or local laws must be resolved in favor of adherence to laws. Local laws which govern fraud and abuse, privacy protection, copyright protection, and governments rights to information access must be addressed and adhered to in the derivative policies of businesses which fall under those jurisdictions. Security architects and other implementers of this policy must be aware of the pertinent laws, for example, those which govern the use of and exportation/importation of cryptographic mechanisms and related materials. Security policies entered into by XYZ with other corporations and outside organizations must become part of this policy by inclusion or by reference.

## 2.3 Responsibilities

The preparation, modification, coordination, and promulgation of this policy is the responsibility of XYZ Corporation. The principal security focus within XYZ for these responsibilities is the Corporate Information Security Officer (CISO). The CISO is appointed by (Executive Committee e.g.)\_\_\_\_. The CISO is responsible to the Corporation for the implementation of this security policy. The CISO is responsible for the coordination of information security activities with those of other corporate security administrators such as those responsible for security guards or police or security investigations. The CISO shall recommend individuals for appointment as XYZ divisional Business Information Security Officers (BISO). The CISO recommendations for BISOs will be approved by (Division Executive e.g.)\_.

BISOs shall prepare business security policies consistent with this policy that govern the information protection requirements of their individual businesses. The BISO is also responsible for modification and coordination of business security policies. The business security policies must define any needed policy governing the interactions with other XYZ businesses. BISOs shall define within their policies how information domains are formed and how security administrators are designated to manage those information domains.

Information systems which are intended to implement and satisfy security policies must be certified and accredited. Certification is the process of security evaluation and reporting on the adequacy of a system to meet the requirements of a security policy. Accreditation is the process of approval and operational acceptance of a system which includes security. Accreditors are chosen from XYZ management to evaluate the effectiveness of their information systems in

meeting business objectives and the adequacy of its system management. BISOs are responsible for defining and managing the certification and accreditation processes.

All XYZ employees have some responsibility in protecting business information. Users of information must be made aware of security policies and must be informed of their responsibilities in meeting the protection requirements for any information that they manage. BISOs shall insure that all employees are informed of the responsibilities that they assume by virtue of their employment and all specific assignments.

## 2.4 Procedures

Security policies vary in their formality depending upon the scope or the number of people involved. A corporate security policy, for example, needs wide dissemination and coordination with many individuals and with all business divisions. Changes require similar efforts to accomplish. Formal processing of such a policy is a necessity. Section III of this document provides guidance for the preparation of such policies. Perhaps the simplest form of policy is when an individual employee prepares information such as a drafted document which for a time is accessible only by the originator. This event is the formation of an information domain with a single member who accepts that the protection of the environment and the information system utilized is adequate. The employee is the certifier and accreditor of the system and this policy may be simply implied. All security policies should be reviewed periodically for continued need. Any changes in environment or systems should be evaluated by the certifiers and accreditors for adequacy of protection.

Information protection shall be considered in the planning, development, and use of all XYZ information systems. This applies to stand alone (including personal) computers as well as computer networks. Users of information systems must be made aware and must observe the requirements for the protection, i.e. security policy, for any information managed by them on such systems.

Information protection shall be considered as part of all contractual agreements. All parties to contracting with suppliers or customers, for example, must consider the necessity for preparing and including a security policy as part of the contract.

Circumstances will sometimes create the need to circumvent normal protection mechanisms. For example, the release of information to non-members of an information domain may be required in an emergency. The appropriate method for dealing with such contingencies is to decide who is permitted to override protection mechanisms and who will audit such activities. These are examples of the possible roles for security administrators. Such contingencies can and should be addressed in security policies.

Certification and Accreditation of information systems become increasingly important as the number of users, computers, and facilities implementing the system become larger. Formal certification is normally accomplished by expert security analysts. The certifier, with knowledge of the security policy, evaluates the total effectiveness of system security mechanisms and

prepares a certification report. The report may recommend system acceptance or it may cite deficiencies which must be mitigated or eliminated prior to acceptance. Formal accreditation is normally accomplished by those who prepared the original operational requirements. The accreditor makes the critical decision to accept or reject a system and to permit its operational use. Selection of certifiers and accreditors must be accomplished as part of the security policy preparation function.

## 2.5 The XYZ Corporate Information Management Model (C/IMM)

The basis for developing the security policy for XYZ is the corporate information management model (C/IMM). An IMM defines who engages in what functions using what information. The XYZ C/IMM is the composite view of the corporation which must be further decomposed for each business area or division to a level of definition that is useful for the identification of information domains.

XYZ Corporation is engaged in four major business areas:

### 1) Business Forms

- Design and manufacture of custom business forms
- Print management
- Print outsourcing services

### 2) Business Systems

- Graphics services
- Business equipment
- Business products
- Research
- CRS

### 3) Labels and label systems

- Integrated label systems
- Software products
- Printers and applicators
- Pressure sensitive labels
- Proprietary label products

### 4) Customer Communications Services

- Personalized direct mail
- Direct marketing program development



## UNCLASSIFIED

Appendix H, Annex B  
IATF Release 3.1—September 2002

- Database management and segmentation services
- Mail production outsourcing services
- Bulk Communications Services

Each of the major business areas is composed of Core Business Functions and Infrastructure Functions:

- Core Business Functions
  - Marketing/Sales
  - Customers/Orders
  - Manufacturing/ Vendors/ Supplies
  - Warehousing
  - Distribution/ Transport
- Infrastructure Functions
  - Planning
  - Finance and Accounting
  - Human resources/personnel administration
  - Research
  - XYZ corporate relations
  - Information systems/communications
  - Facilities management
  - Security management

{With some generic assumptions about users and information records that might be found in all XYZ businesses there is sufficient information to analyze threats to corporate information.}

## 2.6 Threat Analysis

The threat analysis is keyed to the functions of the C/IMM. The degree of threat expressed is a relative scale used to express the probability of attack (high, medium, low, none) and the degree of impact (serious, significant, mild, insignificant). The security services are given strength ratings (strong, moderate, minimum, none) to establish relative priority in the provision of protection. The information management elements and the associated security services may not be relevant to a specific division but they are applicable to all occurrences in the XYZ corporation.

### Marketing

**Threats:** Marketing information wherein sales people promote products and service to customers and potential customers, assess markets, quote standard pricing, and acquire information about the competition is threatened (medium) by the possibility of information being lost or damaged. The impact of such loss is considered (mild) requiring an investment in the rebuilding of the information.

**Security Services:** Marketing information shall be protected for data integrity (minimum). Confidentiality is not required. Access controls (minimum) must limit information entry to XYZ personnel with some exceptions for customer inquiry records.

## Sales

**Threats:** Sales information wherein non-standard pricing arrangements are afforded to specific customers, or planning for special sales or agreements is threatened by disclosure (medium) and loss or damage (medium). The impact of disclosure is (significant) and of loss or damage is (mild)

**Security Services:** This sales information requires confidentiality (minimum) and integrity (minimum) in both storage and transfer. Access control (minimum) must limit information entry and disclosure to XYZ sales personnel and information disclosure to only the specific customers involved. I&A (minimum) is required to support the other security services.

## Customers

**Threats:** Information about customers wherein accounts, customer profiles, ordering histories, and customer proprietary information is unique to that customer and threatened by disclosure (medium) and loss or damage (medium). The impact of disclosure of customer proprietary information is (serious) and the disclosure of other customer information is (significant)

**Security Services:** This customer information requires confidentiality (moderate) and integrity (moderate) in both storage and transfer. Access control (moderate) must limit information entry and disclosure to XYZ specific sales personnel and information disclosure to only the specific customers involved. I&A (moderate) is required to support the other security services.

## Orders

**Threats:** Information about orders may contain unique pricing arrangements with (medium) threat of disclosure and (medium) threat of loss or damage. The impact of disclosure is (significant) and of loss or damage is (mild)

**Security Services:** This ordering information requires confidentiality (moderate) and integrity (minimum) in storage and transfer. Access control (moderate) should limit access to specific customers, specific salespersons, specific sales managers, and any financial information users.

## Manufacturing/Vendors/Supplies

**Threats:** Information about products, inventories, requisitions, vendor and supplier contracts, production schedules, is threatened by disclosure (low) and loss or damage (medium). The impact of disclosure is (mild) and of loss or damage is (significant).

## UNCLASSIFIED

Appendix H, Annex B  
IATF Release 3.1—September 2002

**Security Services:** This information is in access (moderate) to authenticated customers (minimum) and XYZ employees. Confidentiality in transfer (minimum), and integrity in storage (moderate) is required.

### **Warehousing/Distribution/Transport**

**Threats:** Information about inventories of products, shipping schedules, carriers, transfers and disposals is threatened by loss or damage (low) but has (significant) impact on service to customers.

**Security Services:** This information is in access (moderate) to authenticated (minimum) customers, and XYZ employees. Integrity (moderate) in storage and transfer and confidentiality (minimum) in transfer is required.

### **Planning**

**Threats:** Information about planning for new products, new business areas, facility and equipment additions or modification, price changes, strategic account management, research, marketing initiatives is threatened by disclosure (low) but can have (significant) impacts through competitor knowledge.

**Security Services:** Access (moderate) to such information is to specifically involved XYZ personnel with confidentiality (moderate) and integrity (minimum) in storage and transfer. Sales personnel are permitted to release information to customers at planned release dates or events. This represents a change in policy for that information which is to be effected by the designated security administrators.

### **Finance and Accounting**

**Threats:** Financial information such as customer accounts receivable, accounts payable, general ledgers, financial reports, purchase orders, banking, payroll, commissions and bonuses, capital expenditures, and capital assets are considered to be threatened by disclosure (high) and loss or damage (medium). The impact of disclosure is (serious) and of loss or damage is (significant).

**Security Services:** This information is in access (strong) to specific finance personnel by information domain, to all auditors and XYZ business area and corporate officers as needed. Confidentiality (strong) and integrity (moderate) in storage and transfer is required. I&A required is (strong).

### **Human Resources/Personnel Administration**

**Threats:** Information about XYZ personnel which permits the administration of payroll and benefits, promotions, assignment of duties, and performance appraisals, is considered threatened by disclosure (medium) and by loss or damage. The impact of disclosure to anyone who does not specifically need to know is (serious). The impact of loss or damage is (significant).

**Security Services:** Access to this information must be (strong) to only those involved in personnel administration and to the specifically involved supervisory personnel. Confidentiality (strong) and integrity (strong) is required for storage and transfer of this information. I&A (strong) is necessary to support the other security services.

## Research

**Threats:** Information pertaining to new products, processes, capabilities, newly applied technologies, patents pending, and trade secrets are considered threatened by disclosure (medium) and by loss or damage (low).

**Security Services:** Access to this information should be (moderate) to the specific research personnel involved, business area managers, and financial budget managers. This information requires confidentiality (moderate) in storage and transfer.

## XYZ Corporate Relations

**Threats:** Information exchanged between corporate divisions of XYZ are threatened by loss or damage (low). The impact of such loss is (mild)

**Security Services:** Access (minimum) to this information should be to XYZ employees. Data integrity requirements are (minimum).

## Information Systems/Communications

**Threats:** XYZ sets high standards in service and product availability to its customers. Information systems are threatened by:

- Processing system failures: malfunctions, errors, deliberate destruction, inadequate performance
- Communications system failures: malfunction, errors, deliberate destruction, inadequate performance
- Application failures: errors, loss, corruption
- Information failure: errors, loss, corruption, spoofing

The probability of one or more of these events occurring is (high) and will result in the disclosure, loss, or damage to information. The impacts are (serious).

**Security Services:** The general application of measures for system integrity (moderate) and communications availability (moderate) including security management auditing, and preventive maintenance is required.

## Facilities Management

**Threats:** Facilities management information when associated with the security management function is threatened by loss or damage (medium). The reliability of electrical power systems, air conditioning, communications channels is a security issue. Information about power systems service providers and product repair services are examples of relevant data.

**Security Services:** Data integrity (minimum) of facilities management data must be maintained.

## Security Management

**Threats:** Implementation of policies and information needed to support the security services are at the core of any possibilities for information protection. Threats of disclosure and loss or damage are (high) and the impacts are (serious). Security management also involves physical security, administrative security, personnel security as well as the technical aspects of information security.

**Security Services:** This information requires integrity (strong) and confidentiality (strong) in storage and in transfer. Access control (strong) and the supporting I&A (strong) for specific security managers is required.

## 2.7 Security Management

Security management is a set of pervasive security mechanisms which support the security services by direct and supervisory administration, automated processes, and by the activities of all information users. CISOs and BISOs were identified and required in section 2.3. These security managers are to appoint other security managers as needed to support the implementation of XYZ information systems. Security managers are also responsible for informing all users of their responsibilities and requirements.

## 3.0 Policy Preparation Guidance

### 3.1 Overview

This section of the document provides guidance for the development of security policies for the major business areas and divisions of XYZ. All policies are to be derived from the XYZ Information Protection Policy found in Section II. The form of security policies varies with the purpose intended. The corporate level policy of Section II provides general rules for all elements of XYZ and directs the development of more specific policies as needed. Business area policies should be based on the specific functions and information management of each business. Business area policies are expected to apply the security services to the more definitive Business

IMMs. Policies installed in information systems tend to address the needs of smaller groups of users and to cover more categories of information. The concept of an information domain provides a means to implement a security policy that applies to specific users and specific information. The information domain is indivisible in policy, membership, and information objects. The information domain policy then is the ultimate objective in the preparation and implementation of formally and informally adopted policies.

## 3.2 Purpose

This guide describes the process that was used to develop the XYZ corporate policy and is to be used in the development of derivative policies.

## 3.3 Process

The major steps in policy development are:

- Determination of the major functions from a business analysis
- Preparation of an information management model (IMM) from the information management functions used to support the major business functions.
- Performance of a threat analysis based upon the intentions of adversaries to harm the business
- Revision of the IMM to enable the improved allocation of security services
- Allocation of security services to users, processes, databases, and information flows

Each of these steps are described in the following paragraphs assuming the XYZ Information Protection Policy as a baseline.

## 3.4 Business Analysis

Each business area is assumed to have the functions presented in section 2.7 and repeated here. They are:

- Core Business Functions
  - Marketing/sales
  - Customers/orders
  - Manufacturing/ Vendors/ supplies
  - Warehousing
  - Distribution/ transport
- Infrastructure Functions
  - Planning

- Finance and accounting
- Human resources/personnel administration
- Research
- XYZ Corporate relations
- Information systems/communications
- Facilities management
- [Security management]

It is worth repeating that the emphasis is on functions not organizations. It is unlikely that the two are well aligned. It is likely however that individual business areas may differ functionally from those given as the core and infrastructure sets. Any additions or deletions should be made at this step. The functions are the framework for modeling the information management and it is therefore important that the set is as complete as possible.

## 3.5 IMM preparation

For each of the functions it must now be determined if and how information management is used to support them. This part of the process begins with the identification of any **information** being recorded and stored on any kind of media including paper forms and logs, video, audio, as well as the typical computer storage media. Next, any **processes** which generate, transfer, transform, edit, or destroy the information records are identified. **Then the roles of any users** who manage other users, the processes, or the information records directly must be identified. Finally, the IMM is completed by identifying all **information flows** between users, processes, and information stores. In the C/IMM it was assumed, for example, that each business would have marketing information and that all salespersons, sales managers, and customers would have some form of access to that information. In any specific business area information, users, processes and flows can be identified more clearly.

## 3.6 Threat Analysis

In the C/IMM threats were postulated in section 2.8 for each of the core and infrastructure functions and their associated information management model elements. Threats must be traced from the causes for harm. The causes may be deliberate, accidental, or natural as the examples that follow illustrate.

### Sources of threats

- Competitors
- Foreign companies and governments
- Computer hackers, viruses
- Employees (errors, incompetence, inexperience, fraud, abuse, disgruntled)
- Service providers (errors, negative priorities)
- Product vendors (exaggerations, hidden defects)
- Natural disturbances, disasters, accidents

- Customers (greed, fraud, abuse)
- Miscreants (criminals, saboteurs)

Threats are categorized according to the probability of an attack or the occurrence of a harmful event. The probability metrics of high, medium, low, or none are adequate for most analyses. In the C/IMM, under sales for example, it was assumed that some customers may attempt with medium probability to obtain information about special pricing arrangements for other customers. Threats are mapped to the IMM leading to notions of protection of information stores, processes, information flows, and desirable user activities. Once threats are mapped to the IMM the identification of needed security services can be straightforward. However, the threat analysis may suggest that the restructuring of the IMM may improve the possible allocation of security services. For example, the separation of special customer prices from standard prices in a database makes the rules for access control to prices less complex. In addition, a second metric is needed to assist in the selection of security services. The degree of impact on business or a business function should be decided from the metrics of serious, significant, mild, or insignificant.

## 3.7 Security Services

Security services were defined in Section I. Security services are assigned strength metrics in section 2.8 of strong, moderate, minimum, and none. The choice of metric should be commensurate with the probability and impact of the successful execution of a threat. For example, a highly probable attack on information of insignificant value warrants none to minimum protection. When applied to the IMM the security services can be very specifically identified such as, data confidentiality and data integrity are to be applied to special pricing information while being transferred from storage to the authentically identified customer. The complete set of security services so identified and composed form the core of the security policy.

## 3.8 Coordination

The true worth of a security policy is realized when full coordination with and agreement by the community of users is achieved. Architects and implementers of information systems can proceed with a high degree of confidence that changes will be well controlled

Although not technically policy in the sense of protection requirements, the identification of **certifiers** and **accreditors** in the policy is recommended. Their involvement during the development and coordination phase of policy making will shorten the process and improve the results.



**UNCLASSIFIED**

Appendix H, Annex B  
IATF Release 3.1—September 2002

**This page intentionally left blank**

# **PNE Annex C: Division IPP**

---

[This annex to this document is an unedited (except for company name) example of an actual IPP.]

**XYZ CORPORATION**  
**Business Forms Division**

**Information Protection Policy**

*Establishes the policy of the Business Forms Division for the protection of information that is managed in the process of conducting its business.*

**UNCLASSIFIED**

Appendix H, Annex C  
IATF Release 3.1—September 2002

**This page intentionally left blank**

# 1.0 Introduction

## 1.1 Purpose

This document establishes the policy of the Business Forms Division for protecting information that is managed in the process of conducting its business. An Information Protection Policy (IPP) is the record of agreement between all parties as to what protection is required. The IPP is also the basis for guiding the development of information system security architectures, their implementation, and their management during operation.

## 1.2 Background

Policy of the Business Forms Division, a division of XYZ Corporation, is guided by corporate policy (Reference A, Section 1.3) and the procedures it defines. This policy is derived from corporate policy and from the Information Management Model (IMM) for Business Forms Division (Reference B, Section 1.3). The IMM identifies the information domains that must be implemented to support protection of business functions. Information domains are formed by organizing information, processes, and users and selecting the security services to be applied based on threats to business functions. Information domains, security services, and strengths of service are presented in this IPP.

## 1.3 References

- A. XYZ Corporation. Information Protection Policy, <date>.
- B. Business Forms Division. Information Management Model, <date>.
- C. ISO 7498-2, Information Processing Systems-Open Systems Interconnection—Basic Reference Model—Part 2—Security Architecture, February 1989 (CCITT Recommendation X.800)

## 1.4 Definitions

The definitions provided in Reference A are repeated here, with others, for convenience.

**Information:** Data elements or objects generated, transferred, stored, processed, and destroyed in the conduct of business functions.

**Users:** individuals or groups of people who are responsible for managing a portion of the business information. Users include those who employ or manage information systems.

## UNCLASSIFIED

Appendix H, Annex C  
IATF Release 3.1—September 2002

**Processes:** the functions performed by users or users aided by information systems which generate, transform, modify, collect, organize, present, and destroy information.

**Information Management Model (IMM):** a logical description of information management which depicts the users, processes, databases, and information flows which support a business enterprise.

**Information Domain:** a security entity composed of three elements:

- 1) identifiable information objects
- 2) membership of identifiable users
- 3) a security policy which defines the relationships between each member and all of the information objects.

**Information Domain Member:** a user identified to have some responsibilities or privileges in the management of the objects of an information domain

**Security Policy:** rules which govern and identify the relationships between members and the objects of an information domain.

**Security Services:** activities that assist in, or provide for, the protection of information. Security services are provided by security mechanisms. Security mechanisms are diverse and include such things as guards, fences, cryptographic software, badges, or labels. The security services defined here are mutually supporting and often overlapping in the services provided. Although the definitions are provided in terms of people as individuals, they apply to groups, processes, and other agents or objects. These security service definitions are based on those defined by international standards (Ref. C)

**Identification and Authentication (I&A):** The service which protects against the claims of individuals to be someone they are not. Identification is the establishment of the unique identity of an individual, group, or information system component. Authentication is the means for verifying the claimed identity.

**Access Control:** The service which protects information through the control of authorizations of individuals for knowledge or rights of manipulation.

**Confidentiality:** The service that protects information from knowledge or disclosure.

**Integrity:** The service that protects information from modification, damage, or loss.

**Availability:** The service that protects the individual from accidental or deliberate denial of access to information and other services.

**Non-repudiation:** The service which provides protection from an individual denying sending information (non-repudiation with proof of origin), or protection from an individual denying

receiving information (non-repudiation with proof of delivery). These services are closely related to signing and notarization.

## **2.0 General Policy**

### **2.1 Overview**

This section of the IPP contains the general requirements for the protection of information by Business Forms Division and by those individuals and organizations involved in sharing information with the division. Specific requirements imposed by the security services of information domains are presented in section III and is summarized as a composite information domains database in Annex A. This type of policy is independent of implementation and its stated requirements may be satisfied by combinations of environmental, procedural, and technical (hardware, software, etc.) security mechanisms. The selection of mechanisms is accomplished by security architects and implementers of the information systems.

This IPP also defines the administrative procedures and responsibilities necessary to assure its implementation and to manage changes and additions.

The development of the IMM and this IPP were accomplished with the knowledge of several important business policies of the XYZ Corporation and Business Forms Division. Service to customers is the paramount objective and that demands high availability of information systems and the information needed to serve. This involves access to information about the status of some processes internal to the division. Protection of customer and Business Forms Division proprietary information from disclosure is a serious concern. Finance and accounting and personnel information are fundamentally protected with high priority.

### **2.2 Applicability**

The interests of Business Forms Division extend beyond its own employees and assets to customers, vendors, suppliers, other XYZ divisions, financial institutions, and to XYZ Corporation. This IPP is applicable directly to users of information systems and assets of Business Forms Division and indirectly through other policies that are developed in accordance with its procedures. Agreements for information protection with entities external to the division, expressed or implied, must be consistent with the requirements of this IPP. Other Business Forms Division security or information protection policies existing prior to this IPP must be replaced or brought into agreement with this IPP.

### **2.3 Responsibilities**

The Business Information Security Officer (BISO) shall be responsible for the preparation, maintenance, administration, and implementation of this IPP. The (Division Executive e.g.) shall appoint the BISO considering the XYZ employees recommended by the Corporate

## UNCLASSIFIED

Appendix H, Annex C  
IATF Release 3.1—September 2002

Information Security Officer (CISO). The BISO shall insure that the Business Forms Division IPP is consistent with the XYZ Corporation IPP. The BISO shall appoint Information Security Officers (ISO), as needed, to manage the policies and implementations of the major information domains.

The ISOs are the security managers of information domains. They shall initialize and maintain users privileges and support the required security mechanisms. ISOs may manage more than one information domain but the BISO should isolate the management of the most sensitive domains for better security. The BISO and ISOs shall coordinate with other security administrators, e.g. security guards and personnel investigators, as part of their total security management implementation.

All Business Forms Division employees have some responsibility in protecting business information. Users of information must be made aware of information protection policies and must be informed of their responsibilities in meeting the policy requirements for any information that they manage.

In establishing relationships with customers, vendors, suppliers, and other external organizations, policies for the entrusted sharing of information shall be applied or developed. The BISO shall approve all policies applied or developed for use involving external organizations. All such policies must become part of the IPP by inclusion or by reference.

## 2.4 Procedures

Security policies vary in their formality depending upon the scope or the number of people involved. A corporate security policy, for example, needs wide dissemination and coordination with many individuals and with all business divisions. Changes require similar efforts to accomplish. Formal processing of such a policy is a necessity. The XYZ Corporation IPP provides guidance for the preparation of such policies. Perhaps the simplest form of policy is when an individual employee prepares information such as a drafted document which for a time is accessible only by the preparer. This event is the formation of an information domain with a single member who accepts that the protection of the environment and the information system utilized is adequate. The employee is the certifier and accreditor of the system and this policy may be simply implied. All security policies should be reviewed periodically for continued need. Any changes in environment or systems should be evaluated by the certifiers and accreditors for adequacy of protection.

Information protection shall be considered in the planning, development, and use of all Business Forms Division information systems. This applies to stand alone (including personal) computers as well as computer networks. Users of information systems must be made aware and must observe the requirements for the protection, i.e. policy, for any information managed by them on such systems.

Information protection shall be considered as part of all contractual agreements. All parties to contracting with suppliers or customers, for example, must consider the necessity for preparing and including a security policy as part of the contract.

Circumstances will sometimes create the need to circumvent normal protection mechanisms. For example, the release of information to non-members of an information domain may be required in an emergency. The appropriate method for dealing with such contingencies is to decide who is permitted to override protection mechanisms and who will audit such activities. These are examples of the possible roles for security administrators. Such contingencies can and should be addressed in information protection policies.

## 2.5 Certification and Accreditation

Information systems which are intended to implement and satisfy information protection policies must be certified and accredited. Certification is the process of security evaluation and reporting on the adequacy of a system to meet the requirements of a policy. Accreditation is the process of approval and operational acceptance of a system which includes security. Accreditors evaluate the effectiveness of their information systems in meeting business objectives and the adequacy of its system management. Certification and Accreditation of information systems become increasingly important as the number of users, computers, and facilities implementing the system become larger. Formal certification is normally accomplished by expert security analysts. The certifier, with knowledge of the security policy, evaluates the total effectiveness of system security mechanisms and prepares a certification report. The report may recommend system acceptance or it may cite deficiencies which must be mitigated or eliminated prior to acceptance. Formal accreditation is normally accomplished by those who prepared the original operational requirements. The accreditor makes the critical decision to accept or reject a system and to permit its operational use.

The BISO shall select system evaluators and shall be responsible for defining and managing the certification and accreditation processes. Accreditation is the responsibility of the operational organization. The BISO shall certify all Business Forms Division information systems.

## 3.0 Information Domain Policies

### 3.1 General

All users of Business Forms Division must be made aware of their participation in any information domain for the purpose of understanding their responsibilities. Users who retain authentication information must be made aware of their responsibilities for its protection.

**Annex A** summarizes the information domains defined in the Business Forms Division IMM. The IMM specifies the rules for access and permissible processes for the various users. It also



summarizes the relevant threats, their potential and impact, as well as security services and strengths required by the information domains. Any other specific requirements or explanations are provided, by information domain, in the succeeding paragraphs.

The security services and strengths apply to information in use, storage, and in transfer. Security architects and security evaluators shall include mechanisms for availability, integrity, and non-disclosure for information in all of those states, as appropriate.

## 3.2 Systems Entry

### **INFORMATION DOMAIN: System Entry**

Unidentified users may choose between inquiring about products and services or entering the Order process with a customer identification (which includes, new customer). General Business Forms Division information about products, pricing, available inventory, and services is provided to “Potential Customers” through the Marketing and Warehousing processes.

## 3.3 Order Process

### **INFORMATION DOMAIN: Customer Identification**

Unidentified users, may enter customer identification information for the purpose of building a new customer profile, referencing an existing customer profile, placing orders, creating new forms design, reviewing or adjusting orders, or inquiring about products and services. Identification is by one of several submitted items including customer name or telephone number. The expected users are potential customers, customers, sales representatives, account managers, or sales managers, but the user’s identification is not required. This order process domain performs a context switch to the appropriate order process domain, based on the identification information provided.

### **INFORMATION DOMAIN: Customer Information and Order Management (one/customer)**

**New Profile:** Information from customer identification is used to determine if a customer profile exists or if a new profile needs to be generated. If a profile does not exist the unidentified user can create a profile by supplying the required customer information. Completion of the customer information part of the new profile will initialize the generation of authentication data for the customer and identify/assign the customer’s sales representative. The unidentified user is assigned the privileges of the identified new customer. All user activities are restricted to the new account of the identified customer. When the customer enters the order process on subsequent accesses, they will identify themselves with the appropriate customer account information, and be authenticated as a valid user of the existing profile.

**Existing Profile:** If a user wishes to review or adjust information in an existing profile or perform ordering functions, customer identification information must be provided first, followed

by the completion of user identification and authentication (I&A). This establishes the user's privileges in profile management and ordering within the customer account. Successful user I&A permits the customer, the assigned sales representative, and any account manager to modify the customer profile, enter orders, adjust orders, and activate orders. Warehouse, manufacturing, and finance employees can view this part of the customer profile and ordering data but cannot create or modify information in this information domain.

#### **INFORMATION DOMAIN: Customer Pricing**

**Pricing Agreements:** The customer's sales representatives, the specific account manager, and designated finance employees may establish unique pricing agreements between Business Forms Division and a customer. These pricing agreements are only disclosed to those users.

**Order Price Quotes:** The customer's sales representative, the specific account manager, and designated finance employees may establish prices for products and services requested in an order. The customer and designated warehouse and manufacturing employees may view this information. Order pricing is only disclosed to those users.

#### **INFORMATION DOMAIN: Customer Order Credit Approval**

Information about the approval for customer credit on each order is provided by designated finance employees. The customer may not access this credit information.

#### **INFORMATION DOMAIN: New Forms Design**

New forms may be designed by customers and others and be filed in customer specific files. This domain is separated from the customer information and order management domain because it allows a manufacturing design engineer read and write access to the new form information, to assist in its final fabrication, before entering the manufacturing order processing and production processes.

## **3.4 Manufacturing**

Manufacturing provides the production and distribution of Business Forms Division forms products. The manufacturing process is composed of six information domains.

#### **INFORMATION DOMAIN: Standard Items Update**

Operations and Production employees maintain records of general product catalog items produced and shipped to warehouses.

#### **INFORMATION DOMAIN: Customer Orders**

Operations and Production employees maintain records of production against customer orders. This includes requests to manufacturing for new forms design. Records are viewable by many

## UNCLASSIFIED

Appendix H, Annex C  
IATF Release 3.1—September 2002

who need to see them but the records are kept one per customer, to limit access to the account to which the order information belongs.

### **INFORMATION DOMAIN: Raw Materials**

Operations and Production employees maintain records about ordering, receiving, and inventory of raw materials used for forms production.

### **INFORMATION DOMAIN: Distribution**

Production employees maintain records about carriers and warehouses.

### **INFORMATION DOMAIN: Design**

Design engineers place new general product form designs into the general catalog.

### **INFORMATION DOMAIN: Production Control**

Users manage the manufacturing process runs.

## **3.5 Warehouse**

The warehousing process is divided into five information domains. Three of the domains are created to maintain separation of different types of inventories. The other two deal with warehouse accounting management (shipping, receiving invoice management, notifications, etc.) and independent inventory audits that provide accounting oversight of the Business Forms Division warehousing process.

### **INFORMATION DOMAIN: Internal Use Products Inventory**

The internal use products inventory is an ongoing storage record of manufacturing raw materials, facilities management office supplies and utilities parts and components, and IS/Comm management spare parts and system components, where such items are maintained in a Business Forms Division managed warehouse. Only valid and verified manufacturing, facilities management, IS/Comm management employees, and warehouse employees may read this information. Only warehouse stock movement employees may update this information.

### **INFORMATION DOMAIN: Customer Products Inventory**

The customer products inventory is maintained on a account basis (1 domain per customer) and provides the product items the customer has stocked in the warehouse at any point in time. Only the customer and those Business Forms Division employees representing the customer, and warehouse employees may read this information. Only warehouse stock movement employees may update this information.

### **INFORMATION DOMAIN: General Products Inventory**

The general products inventory is maintained on a general catalog products basis (no specific customer ownership) and provides the product items available to any customer or potential customer which is stored in the warehouse at any point in time. Anyone may read this information. Only warehouse stock movement employees may update this information. Inventory which is “earmarked” for outgoing customer shipment is not included in the available inventory quantities.

#### **INFORMATION DOMAIN: Warehouse Accounting**

The warehouse accounting domain processes all incoming and outgoing invoices and all incoming customer orders which get transformed and referenced in outgoing invoices, and warehouse status information about customer orders. This domain also issues notification to finance & accounting (AR) about customer order shipments, for billing and collection and for credit memo generation for customer returned products, and (AP) about the receiving of internal XYZ products shipped to the warehouse by suppliers. Any valid and verified XYZ employee may be granted authorization to read this information. Customers may read the information related to their account. Only authorized warehouse employees may write this information.

Where internal stock items are shipped directly to the Business Forms Division organization that ordered the items, vice going to warehouse inventory, then the ordering organization is responsible for the accounting management of such items, including notification of delivery to finance and accounting (AP). Where customer orders are filled, invoiced, and shipped directly to the customer by the manufacturing process, vice going to warehouse inventory for later shipping to customer, then the manufacturing organization is responsible for the accounting management of such items, including the notification of shipping to finance and account (AR).

#### **INFORMATION DOMAIN: Inventory Audit**

The inventory audit domain processes independent warehouse inventory counts and invoice reviews to ensure the integrity of warehouse management, and reconciles or instigates an investigation of unbalanced records and stock item counts. Only internal and/or external independent inventory audit personnel may read and write this information. Only warehouse management personnel, and Business Forms Division and corporate executives may read this information.

## **3.6 Business Planning**

#### **INFORMATION DOMAIN: Business Plans**

The users in this domain are Business Forms Division’s Executives, their staffs, and sales, manufacturing and financial managers. Only the executives and their staffs are allowed to create modify or destroy the information objects. Although the impact of loss of this strategic information is considered significant the threat to the loss or damage of the information is considered low. Moderate access control must be used to restrict the information to the

executives and senior managers. There are moderate confidentiality and minimal integrity requirements in both storage and transport of this information.

## 3.7 Marketing

### **INFORMATION DOMAIN: Promotion**

Sales managers and analysts maintain product catalogs and price information which are available to the general public as potential customers. This domain also includes promotional brochures and other forms of advertising (web pages?). The accessibility of this information is both desirable and threatening. Care must be taken to provide adequate separation for the protection of other domains. The access rules here indicate that unidentified users may view this information but any authenticated sales managers or analysts may prepare it.

### **INFORMATION DOMAIN: Customer (one/customer)**

The customer's sales representative or any sales analyst may record information about the customer's history or preferences as part of the customer profile. This domain also includes any unique pricing or buying agreements. The customer and any sales manager may view this record.

### **INFORMATION DOMAIN: Strategy**

Sales managers and analysts maintain marketing management and planning information to include establishing price ranges to be used in quoting prices for orders. This is a marketing user only domain except that division executives can view the information.

### **INFORMATION DOMAIN: Sales**

Sales analysts maintain statistics on a per customer basis which will indicate sales performance.

## 3.8 Finance and Accounting

### **INFORMATION DOMAIN: Management**

Financial managers and designated employees manage the division's finances. Posting to the general ledger involves transfers of information from the other finance domains. Inter-domain transfers require that transfer policies exist in each pair of domains involved in the transfer and that the user has the privilege to do it.

### **INFORMATION DOMAIN: Customer (one/ customer)**

Finance employees maintain credit and payment records, against accounts receivable, by customer. This information is available to the customer's sales representative and sales manager.

**INFORMATION DOMAIN: Deliveries**

Finance, warehouse, and manufacturing employees post accounts receivable by virtue of their deliveries.

**INFORMATION DOMAIN: Expenditures**

All employees who may obligate the division post expenditures.

**INFORMATION DOMAIN: Payroll**

Records of payroll disbursements, commissions and bonuses are kept by finance employees. This information is available to Human Resources personnel.

## 3.9 Personnel

**INFORMATION DOMAIN: Personnel: Employee-H/R Managed**

This is a set of domains; one per employee. The users of the domain are the specific employee, H/R personnel and financial personnel. The domain contains sensitive information about a specific employee. The domain requires strong identification and authentication and access control to insure that only the users of the domain have access to the information and to insure the integrity of the information by establishing and controlling the user's privileges. There are two processes that run in this domain; manage employee records and payroll processing. The payroll process is limited to financial personnel and can only read the information. Manage employee records is limited to the specific employee and H/R personnel where only H/R personnel can create, modify or destroy the information objects. There are strong confidentiality and integrity requirements for the information objects during storage and transportation.

**INFORMATION DOMAIN: Personnel: Employee Managed Records and Payroll**

This is a set of domains; one per employee. The users of the domain are the specific employee, H/R personnel and financial personnel. The domain contains sensitive information about a specific employee. The domain requires strong identification and authentication and access control to insure that only the users of the domain have access to the information and to insure the integrity of the information by establishing and controlling the user's privileges. There are two processes that run in this domain; manage employee records and payroll processing. The payroll processing is limited to financial personnel and can only read the information. Manage employee records is restricted to the specific employee and H/R personnel where both the specific employee and H/R personnel can create modify or destroy the information objects. There are strong confidentiality and integrity requirements for the information objects during storage and transportation.

## UNCLASSIFIED

Appendix H, Annex C  
IATF Release 3.1—September 2002

### **INFORMATION DOMAIN: Personnel: H/R Management**

The information in this domain is accessible to all XYZ employees. However the integrity of the information must be strongly protected. Therefore the domain requires strong identification and authentication of H/R personnel before they are allowed to create modify or destroy the information objects. There is a strong integrity requirement for the information objects during storage and transportation.

### **INFORMATION DOMAIN: Personnel: Division Policy**

The information in this domain is accessible to all XYZ employees. However, the integrity of the information must be strongly protected. Therefore the domain requires strong identification and authentication of Business Forms Division Executives before they are allowed to create modify or destroy the information objects. There is a strong integrity requirement for the information objects during storage and transportation.

## **3.10 Information Systems and Communications**

The information systems (IS) and communications management infrastructure process is composed of eleven information domains. Here, IS and communications management functions have been separated on purpose, to maintain integrity of these two major infrastructure processes, although in reality they may be managed as (or at least by) a single Business Forms Division entity. The IS process includes management, maintenance, trouble reporting, and applications management domains. The communications process includes management, maintenance, and trouble reporting domains. Jointly coupled IS/Comm domains include capital equipment inventory control, system planning, system integration activities and information, and contracts management.

### **INFORMATION DOMAIN: IS Management**

The IS management information domain is very broad based. It includes all major system management activities necessary to configure, account for and operate Business Forms Division end system components (workstations, servers, mainframes, telephones, fax machines, etc.). Users of this domain are IS managers and operators. Overall system administration is maintained and controlled by this domain.

### **INFORMATION DOMAIN: IS Maintenance**

The IS maintenance domain provides the information and processes to maintain and control routine and specific end system preventative maintenance functions. IS operators and maintenance personnel (including contract maintenance personnel) are the users of this domain.

**INFORMATION DOMAIN: IS Trouble Reporting**

The IS trouble reporting domain provides the process and information for users to reports problems and get those problems resolved. Users may report problems and request assistance via telephone, person to person, or electronic mail. User may read problem resolution information. Only IS help desk personnel may read and write the information in this domain.

**INFORMATION DOMAIN: Applications**

The applications management domain provides the process and information to initialize and modify application specific parameter information. This domain includes specific server data base maintenance functions. Only applications management and maintenance personnel may read and write application management information. They directly support the primary users of the specific applications (e.g., ABC and DEF Business Forms Division applications).

**INFORMATION DOMAIN: Communications Management**

The communications management domain includes all major local and wide area communications management activities necessary to monitor, configure, account for and trouble shoot problem origin for Business Forms Division communication relay system components. Users of this domain are IS/Comm managers and communication operators/tech controllers, who are allowed to both read and write information objects in this domain. Overall communications administration is maintained and controlled by this domain.

**INFORMATION DOMAIN: Communications Maintenance**

The communications maintenance domain provides the information and processes to maintain and control routine and specific communications component preventative maintenance functions. Communications operators/tech controllers and maintenance personnel (including contract maintenance personnel) are the users of this domain.

**INFORMATION DOMAIN: Communications Trouble Reporting**

The communications trouble reporting domain provides the process and information for users to report communication problems and get those problems resolved. Users may report problems and request assistance via telephone, person to person, or electronic mail. All users may read problem resolution information. Only communications help desk personnel may read and write the information in this domain.

**INFORMATION DOMAIN: Inventory**

The inventory domain is used to maintain an accurate IS/Comm record of hardware and software and spare parts capital equipment (owned) and leased equipment, which is managed by IS/Comm. It may or may not contain IS/Comm inventory maintained in the warehouse, if such equipment (e.g., spares and transition components) are to be stored in one or more XYZ warehouses. IS/Comm managers, optionally IS/Comm outsource contractors, and both Business Forms Division and corporate executives may read this information. One or more assigned



## UNCLASSIFIED

Appendix H, Annex C  
IATF Release 3.1—September 2002

capital equipment administrators are the only ones who may read and write (maintain) this information. This record is maintained for finance and accounting tax purposes and asset accounting purposes. This record is subject to periodic F&A audits.

### **INFORMATION DOMAIN: Planning**

The planning domain is used to maintain an accurate IS/Comm record of planning information. This domain may contain information such as engineering plans, concept of operations documents, transition plans, development schedules, procurement plans, etc. IS/Comm managers and their staff have read and write access to this information. All other users, defined by IS/Comm management, have read access to this information.

### **INFORMATION DOMAIN: Integration**

The integration domain is used by the IS/Comm management staff to coordinate and oversee all information system and communication integration efforts. It includes integration planning documents, schedules, testing documents, procured equipment invoices, etc. related to any ongoing, planned, or past/archived integration activity.

### **INFORMATION DOMAIN: Contracts**

The contracts domain is used to guide, direct, monitor, instill adjustments to, and maintain status information on all IS/Comm contracts to Business Forms Division and/or other XYZ divisions as may be appropriate from time to time. IS/Comm contract managers and an assigned finance and accounting representative and manager have read and write access to the contracts information in this domain. Others, authorized by the IS/Comm manager are allowed read access to this information. There is a separate contracts domain for each contractor utilized by Business Forms Division.

## **3.11 Facilities Management**

### **INFORMATION DOMAIN: Office Supplies**

The office supplies domain is used by either an office manager or an administrator assigned by an office manager to maintain an inventory of office supplies used by the office. The manager or designated administrator orders supplies, may maintain an inventory of supplies in the warehouse, or at the local facility where the office resides. The manager or administrator notifies finance and accounting about supplier purchase orders and invoice receipt of received goods from suppliers if the inventory is maintained by the office. If the inventory is maintained by the warehouse, then the warehouse notifies finance and accounting about received goods and the cost. Any office employee may read the inventory or order information. The manager and/or designated administrator is the only one(s) who may write this information.

**INFORMATION DOMAIN: Facilities and Utilities**

The facilities and utilities domain provides the processes and information to account for facilities maintenance, outages, improvements, and utility cost monitoring. The facility manager or one or more designated facilities management employees may write this information. Any Business Forms Division employee may read this information.

## 3.12 Corporate Relations

**INFORMATION DOMAIN: Corporate Reporting**

The users in this domain are Business Forms Division and XYZ Corporate Executives and their staffs. This is reporting information that can be created modified and destroyed by Business Forms Division and executives and their staffs. There are minimum protection requirements for this information in storage and transfer. And minimal access control, and identification and authentication to protect the integrity of the information.

## 3.13 Security Management

The security management process is comprised of three different domain types: systems, mechanisms, and information domains. The international standard terminology for such information is the Security Management Information Base (SMIB). The SMIB is divided into the three types of domains.

**INFORMATION DOMAIN: Systems**

Each information end system or relay system contains protected information objects which are initialized and maintained by either an ISO or a designated system security manager (SSM). These managed objects may be managed locally or remotely. They include information which establishes and maintains information domains users and policies which are allocated to system level management.

**INFORMATION DOMAIN: Mechanisms**

Some security mechanism require individual support information which must be separated from any other security management for high protection. This includes e.g. cryptographic key material or mechanism attributes. This part of the SMIB may be managed by ISOs or SSMs.

**INFORMATION DOMAIN: Domains**

Each information domain requires a security management domain which contains its membership and policy. This domain may be managed at the system level by the SSM or in a separate domain which is managed by individual members of the domain or by ISOs.

**UNCLASSIFIED**

Appendix H, Annex C  
IATF Release 3.1—September 2002

**This page intentionally left blank**

# Appendix I

# Mission-Oriented Risk Analysis

---

This is being developed and will be available later this year.

**UNCLASSIFIED**

Appendix I  
IATF Release 3.1—September 2002

**This page intentionally left blank**

# Appendix J

## ISSE Relationship to Sample SE Processes

---

This appendix relates the Information Systems Security Engineering (ISSE) process activities to specific processes for systems engineering (SE) and system acquisition. The purpose of this mapping is to help the reader who is familiar with these or similar processes to have a better understanding of the nature of the ISSE activities and of the SE skills involved. A discussion of the ISSE process is included in Information Assurance Technical Framework (IATF) Chapter 3, The Information Systems Security Engineering Process.

The ISSE Master Activity and Task List breaks down the ISSE process activities into tasks and subtasks. Besides the six technical process activities, two program management activities are included: Plan Technical Effort and Manage Technical Effort. The tasks presented in the list are used to map ISSE activities to SE processes in the tables that follow the list.

### ISSE Master Activity and Task List

#### Activity–01 Discover Information Protection Needs

- Task–01.1 Analyze organization’s mission
- Task–01.2 Determine relationship and importance of information to mission
- Task–01.3 Identify legal and regulatory requirements
- Task–01.4 Identify classes of threats
- Task–01.5 Determine impacts
- Task–01.6 Identify security services
- Task–01.7 Document the information protection needs
- Task–01.8 Document security management roles and responsibilities
- Task–01.9 Identify design constraints
- Task–01.10 Assess information protection effectiveness
  - Subtask–01.10.1 Provide/present documented information protection needs to the customer
  - Subtask–01.10.2 Obtain concurrence from the customer in the information protection needs

## UNCLASSIFIED

Appendix J  
IATF Release 3.1—September 2002

### Task–01.11 Support system certification and accreditation (C&A)

- Subtask–01.11.1 Identify Designated Approving Authority (DAA)/Accreditor
- Subtask–01.11.2 Identify Certification Authority/Certifier
- Subtask–01.11.3 Identify C&A and acquisition processes to be applied
- Subtask–01.11.4 Ensure Accreditor's and Certifier's concurrence in the information protection needs

## Activity–02 Define System Security Requirements

### Task–02.1 Develop system security context

- Subtask–02.1.1 Define system boundaries and interfaces with SE
- Subtask–02.1.2 Document security allocations to target system and external systems
- Subtask–02.1.3 Identify data flows between the target system and external systems and the protection needs associated with those flows

### Task–02.2 Develop security Concept of Operations (CONOPS)

### Task–02.3 Develop system security requirements baseline

- Subtask–02.3.1 Define system security requirements
- Subtask–02.3.2 Define system security modes of operation
- Subtask–02.3.3 Define system security performance measures

### Task–02.4 Review design constraints

### Task–02.5 Assess information protection effectiveness

- Subtask–02.5.1 Provide and present security context, security CONOPS, and system security requirements to the customer
- Subtask–02.5.2 Obtain concurrence from the customer in system security context, CONOPS, and requirements

### Task–02.6 Support system C&A

- Subtask–02.6.1 Ensure Accreditor's and Certifier's concurrence in system security context, CONOPS, and requirements

## Activity–03 Design System Security Architecture

### Task–03.1 Perform functional analysis and allocation

- Subtask–03.1.1 Analyze candidate systems architectures
- Subtask–03.1.2 Allocate security services to architecture
- Subtask–03.1.3 Select mechanism types
- Subtask–03.1.4 Submit security architecture(s) for evaluation
- Subtask–03.1.5 Revise security architecture(s)
- Subtask–03.1.6 Select security architecture

**Task–03.2 Assess information protection effectiveness**

- Subtask–03.2.1 Ensure that the selected security mechanisms provide the required security services
- Subtask–03.2.2 Explain to the customer how the security architecture meets the security requirements
- Subtask–03.2.3 Generate risk projection
- Subtask–03.2.4 Obtain concurrence from the customer in the security architecture

**Task–03.3 Support system C&A**

- Subtask–03.3.1 Prepare and submit final architecture documentation for risk analysis
- Subtask–03.3.2 Coordinate results of the risk analysis with Accreditor and Certifier

**Activity–04 Develop Detailed Security Design****Task–04.1 Ensure compliance with security architecture****Task–04.2 Perform trade-off studies****Task–04.3 Define system security design elements**

- Subtask–04.3.1 Allocate security mechanisms to system security design elements
- Subtask–04.3.2 Identify candidate commercial off-the-shelf (COTS)/government off-the-shelf (GOTS) security products
- Subtask–04.3.3 Identify custom security products
- Subtask–04.3.4 Qualify element and system interfaces (internal and external)
- Subtask–04.3.5 Develop specifications

**Task–04.4 Assess information protection effectiveness**

- Subtask–04.4.1 Conduct design risk analysis
- Subtask–04.4.2 Ensure that the selected security design provides the required security services
- Subtask–04.4.3 Explain to the customer how the security design meets the security requirements
- Subtask–04.4.4 Explain to the customer, and document, any residual risks of the design
- Subtask–04.4.5 Obtain concurrence from the customer in the detailed security design



## UNCLASSIFIED

### Task–04.5 Support system C&A

- Subtask–04.5.1 Prepare and submit detailed design documentation for risk analysis
- Subtask–04.5.2 Coordinate results of the risk analysis with Accreditor and Certifier

## Activity–05 Implement System Security

### Task–05.1 Support security implementation and integration

- Subtask–05.1.1 Participate in implementation planning
- Subtask–05.1.2 Verify interoperability of security tools and mechanisms
- Subtask–05.1.3 Verify implementation against security design
- Subtask–05.1.4 Verify that the security components have been evaluated against the selected evaluation criteria
- Subtask–05.1.5 Assist in the integration of the components to ensure that their integration meets the system security specifications and does not alter the component specifications
- Subtask–05.1.6 Assist in the configuration of the components to ensure that the security features are enabled and the security parameters are correctly set to provide the required security services
- Subtask–05.1.7 Ensure that system and component configurations are documented and placed under configuration management

### Task–05.2 Support test and evaluation

- Subtask–05.2.1 Build test and evaluation strategy (includes demonstration, observation, analysis, and testing)
- Subtask–05.2.2 Assess available test and evaluation data for applicability (e.g., CCEP, NIAP, internal)
- Subtask–05.2.3 Support development of test and evaluation procedures
- Subtask–05.2.4 Support test and evaluation activities

### Task–05.3 Assess information protection effectiveness

- Subtask–05.3.1 Monitor to ensure that the security design is implemented correctly
- Subtask–05.3.2 Conduct or update risk analysis
- Subtask–05.3.3 Define the risks and possible mission impacts and advise the customer and the customer's Certifiers and Accreditors

### Task–05.4 Support system C&A

- Subtask–05.4.1 Ensure the completeness of the required C&A documentation with the customer and the customer's Certifiers and Accreditors
- Subtask–05.4.2 Provide documentation and analysis as required for the C&A process

### Task–05.5 Support security training

**Activity–06 Assess Information Protection Effectiveness**

Assessing the effectiveness of the information protection occurs in conjunction with the activities of Discover Information Protection Needs, Define System Security Requirements, Design System Security Architecture, Develop Detailed Security Design, and Implement System Security. The Assess Information Protection Effectiveness task and subtasks are listed with the associated activities.

**Activity–07 Plan Technical Effort**

Planning the technical effort occurs throughout the ISSE process. The information systems security engineer must review each of the following areas to scope support to the customer in conjunction with the other activities. This set of tasks is recognized separately because it is applied similarly across all of the other activities, requires a unique skill set, and is likely to be assigned to senior-level personnel.

- Task–07.1 Estimate project scope
- Task–07.2 Identify resources and availability
- Task–07.3 Identify roles and responsibilities
- Task–07.4 Estimate project costs
- Task–07.5 Develop project schedule
- Task–07.6 Identify technical activities
- Task–07.7 Identify deliverables
- Task–07.8 Define management interfaces
- Task–07.9 Prepare technical management plan
- Task–07.10 Review project plan
- Task–07.11 Obtain customer agreement

**Activity–08 Manage Technical Effort**

Managing the technical effort occurs throughout the ISSE process. The information systems security engineer must review all technical activities and documentation to ensure quality in conjunction with the other activities. This set of tasks is recognized separately because it is applied similarly across all of the other activities, requires a unique skill set, and is likely to be assigned to senior-level personnel.

- Task–08.1 Direct technical effort
- Task–08.2 Track project resources
- Task–08.3 Track technical parameters
- Task–08.4 Monitor progress of technical activities

**UNCLASSIFIED**

- Task–08.5 Ensure quality of deliverables
- Task–08.6 Manage configuration elements
- Task–08.7 Review project performance
- Task–08.8 Report project status

DoD 5000.2-R, Mandatory Procedures for Major Defense Acquisition Programs (MDAP) and Major Automated Information System (MAIS) Acquisition Programs, describes the Systems Engineering Process (SEP) as a comprehensive, iterative, and recursive problem-solving process, applied sequentially, top down. The following table summarizes the DoD 5000.2-R SEP and maps it to similar ISSE tasks.

<b>DoD 5000.2-R Systems Engineering Process</b>	<b>ISSE Process</b>
<p align="center"><b>Systems Engineering Process Inputs</b></p> <ul style="list-style-type: none"> <li>• Customer needs/objectives/requirements                             <ul style="list-style-type: none"> <li>– Missions</li> <li>– Measures of effectiveness</li> <li>– Environments</li> <li>– Constraints</li> </ul> </li> <li>• Technology base</li> <li>• Output requirements from prior development effort</li> <li>• Program decision requirements</li> <li>• Requirements applied through specifications and standards</li> </ul>	<p align="center"><b>Discover Information Protection Needs</b></p> <ul style="list-style-type: none"> <li>• Analyze organization’s mission</li> <li>• Determine relationship and importance of information to mission</li> <li>• Identify legal and regulatory requirements</li> <li>• Identify classes of threats</li> <li>• Determine impacts</li> <li>• Identify security services</li> <li>• Document the information protection needs</li> <li>• Document security management roles and responsibilities</li> <li>• Identify design constraints</li> </ul>
<p align="center"><b>Requirements Analysis</b></p> <ul style="list-style-type: none"> <li>• Analyze missions and environments</li> <li>• Identify functional requirements</li> <li>• Define or refine performance and design constraint requirements</li> </ul>	<p align="center"><b>Define System Security Requirements</b></p> <ul style="list-style-type: none"> <li>• Develop system security context                             <ul style="list-style-type: none"> <li>– Define system boundaries and interfaces with SE</li> <li>– Document security allocations to target system and external systems</li> <li>– Identify data flows between the target system and external systems and the protection needs associated with those flows</li> </ul> </li> <li>• Develop security CONOPS</li> <li>• Develop system security requirements baseline                             <ul style="list-style-type: none"> <li>– Define system security requirements</li> <li>– Define system security modes of operation</li> <li>– Define system security performance measures</li> </ul> </li> <li>• Review design constraints</li> </ul>

DoD 5000.2-R Systems Engineering Process	ISSE Process
<p><b>Functional Analysis/Allocation</b></p> <ul style="list-style-type: none"> <li>Decompose to lower-level functions</li> <li>Allocate performance and other limiting requirements to all functional levels</li> <li>Define or refine functional interfaces (internal and external)</li> <li>Define/refine/integrate functional architecture</li> </ul>	<p><b>Design System Security Architecture</b></p> <ul style="list-style-type: none"> <li>Analyze candidate systems architectures</li> <li>Allocate security services to architecture</li> <li>Select mechanism types</li> <li>Submit security architecture(s) for evaluation</li> <li>Revise security architecture(s)</li> <li>Select security architecture</li> </ul>
<p><b>Requirements Loop</b></p> <ul style="list-style-type: none"> <li>Reconsider Requirements Analysis to establish traceability of functions to requirements</li> </ul>	<p><b>Assess Information Protection Effectiveness</b></p> <ul style="list-style-type: none"> <li>Provide/present documented information protection needs to the customer</li> <li>Identify the processes, information, users, threats, and security services that are important to the mission or business</li> <li>Explain security services, strengths, and priorities</li> <li>Provide/present security context, security CONOPS, and system security requirements to the customer                             <ul style="list-style-type: none"> <li>Explain allocations to the target and external systems</li> <li>Ensure that the security mechanisms of the system meet the mission security needs</li> <li>Obtain concurrence the customer</li> </ul> </li> </ul> <p><b>Support System C&amp;A</b></p> <ul style="list-style-type: none"> <li>Identify DAA/Accreditor</li> <li>Identify Certification Authority/Certifier</li> <li>Identify C&amp;A and acquisition processes to be applied</li> <li>Ensure Accreditors and Certifiers concurrence                             <ul style="list-style-type: none"> <li>System Security Context</li> <li>Security CONOPS</li> <li>System Security Requirements</li> </ul> </li> </ul>
<p><b>Synthesis</b></p> <ul style="list-style-type: none"> <li>Transform architectures (functional to physical)</li> <li>Define alternative system concepts, configuration items, and system elements</li> <li>Select preferred product and process solutions</li> <li>Define or refine physical interfaces (internal and external)</li> </ul>	<p><b>Develop Detailed Security Design</b></p> <ul style="list-style-type: none"> <li>Ensure compliance with security architecture</li> <li>Perform trade-off studies</li> <li>Define system security design elements                             <ul style="list-style-type: none"> <li>Allocate security mechanisms to system security design elements</li> <li>Identify candidate COTS/GOTS security products</li> <li>Identify custom security products</li> <li>Qualify element and system interfaces (internal and external)</li> </ul> </li> <li>Develop specifications</li> </ul>

**UNCLASSIFIED**

<b>DoD 5000.2-R Systems Engineering Process</b>	<b>ISSE Process</b>
<p align="center"><b>Design Loop</b></p> <ul style="list-style-type: none"> <li>• Revisiting the functional architecture to verify that the physical design synthesized the required functions at the required level of performance</li> </ul>	<p align="center"><b>Assess Information Protection Effectiveness</b></p> <ul style="list-style-type: none"> <li>• Conduct design risk analysis</li> <li>• Ensure that the selected security design provides the required security services</li> <li>• Explain to the customer how the security design meets the security requirements</li> <li>• Explain to the customer, and document, any residual risks of the design</li> <li>• Obtain concurrence from the customer in the detailed security design</li> </ul> <p align="center"><b>Support System C&amp;A</b></p> <ul style="list-style-type: none"> <li>• Prepare and submit detailed design documentation for risk analysis</li> <li>• Coordinate results of the risk analysis with Accreditor and Certifier</li> </ul>
<p align="center"><b>Process Output</b></p> <ul style="list-style-type: none"> <li>• Development Level Dependent               <ul style="list-style-type: none"> <li>– Decision database</li> <li>– System and configuration item architecture</li> <li>– Specifications and baselines</li> </ul> </li> </ul>	<p align="center"><b>Implement System Security</b></p> <ul style="list-style-type: none"> <li>• Support security implementation and integration               <ul style="list-style-type: none"> <li>– Participate in implementation planning</li> <li>– Verify interoperability of security tools and mechanisms</li> <li>– Verify implementation against security design</li> <li>– Verify that the security components have been evaluated against the selected evaluation criteria (CCEP, NIAP, FIPS, or other NSA and NIST evaluation criteria)</li> <li>– Assist in the integration of the components to ensure that their integration meets the system security specifications and does not alter the component specifications</li> <li>– Assist in the configuration of the components to ensure that the security features are enabled and the security parameters are correctly set to provide the required security services</li> </ul> </li> <li>• Support test and evaluation               <ul style="list-style-type: none"> <li>– Build test and evaluation strategy (includes demonstration, observation, analysis, and testing)</li> <li>– Assess available test and evaluation data for applicability (e.g., CCEP, NIAP, internal)</li> <li>– Support development of test and evaluation procedures</li> <li>– Support test and evaluation activities</li> </ul> </li> </ul>

DoD 5000.2-R Systems Engineering Process	ISSE Process
<p style="text-align: center;"><b>Verification</b></p> <ul style="list-style-type: none"> <li>• Comparison of the solution to the requirements</li> </ul>	<p style="text-align: center;"><b>Assess Information Protection Effectiveness</b></p> <ul style="list-style-type: none"> <li>• Monitor to ensure that the security design is implemented correctly</li> <li>• Conduct or update risk analysis</li> <li>• Define the risks and possible mission impacts and advise the customer and the customer's Certifiers and Accreditors</li> </ul> <p style="text-align: center;"><b>Support System C&amp;A</b></p> <ul style="list-style-type: none"> <li>• Ensure the completeness of the required C&amp;A documentation with the customer and the customer's Certifiers and Accreditors</li> <li>• Provide documentation and analysis as required for the C&amp;A process</li> </ul>

The ISSE process is mapped to the IEEE Standard for Application and Management of the Systems Engineering Process (IEEE Std 1220-1998) in the table below.

IEEE Std 1220-1998 Systems Engineering Process	ISSE Process
<p style="text-align: center;"><b>Requirements Analysis</b></p> <ul style="list-style-type: none"> <li>• Define customer expectations</li> <li>• Define project and enterprise constraints</li> <li>• Define external constraints</li> <li>• Define operational scenarios</li> <li>• Define measures of effectiveness</li> <li>• Define system boundaries</li> <li>• Define interfaces</li> <li>• Define utilization environments</li> <li>• Define life-cycle process concepts</li> <li>• Define functional requirements</li> </ul>	<p style="text-align: center;"><b>Discover Information Protection Needs</b></p> <ul style="list-style-type: none"> <li>• Analyze organization's mission</li> <li>• Determine relationship and importance of information to mission</li> <li>• Identify legal and regulatory requirements</li> <li>• Identify classes of threats</li> <li>• Determine impacts</li> <li>• Identify security services</li> <li>• Document the information protection needs</li> <li>• Document security management roles and responsibilities</li> <li>• Identify design constraints</li> </ul>

<p style="text-align: center;"><b>IEEE Std 1220-1998 Systems Engineering Process</b></p>	<p style="text-align: center;"><b>ISSE Process</b></p>
<ul style="list-style-type: none"> <li>• Define performance requirements</li> <li>• Define modes of operations</li> <li>• Define technical performance measures</li> <li>• Define design characteristics</li> <li>• Define human factors</li> <li>• Establish requirements baseline</li> </ul>	<p style="text-align: center;"><b>Define System Security Requirements</b></p> <ul style="list-style-type: none"> <li>• Develop system security context                             <ul style="list-style-type: none"> <li>– Define system boundaries and interfaces with SE</li> <li>– Document security allocations to target system and external systems</li> <li>– Identify data flows between the target system and external systems and protection needs associated with those flows</li> </ul> </li> <li>• Develop security CONOPS</li> <li>• Develop system security requirements baseline                             <ul style="list-style-type: none"> <li>– Define system security requirements</li> <li>– Define system security modes of operation</li> <li>– Define system security performance measures</li> </ul> </li> <li>• Review design constraints</li> </ul>
<p style="text-align: center;"><b>Requirements Verification and Validation</b></p> <ul style="list-style-type: none"> <li>• Compare to customer expectations</li> <li>• Compare to enterprise and project constraints</li> <li>• Compare to external constraints</li> <li>• Identify variances and conflicts</li> <li>• Establish validated requirements baseline</li> </ul>	<p style="text-align: center;"><b>Assess Information Protection Effectiveness</b></p> <ul style="list-style-type: none"> <li>• Provide and present documented information protection needs to the customer</li> <li>• Explain security services, strengths, and priorities</li> <li>• Provide and present security context, security CONOPS, and system security requirements to the customer</li> <li>• Obtain concurrence from the customer</li> </ul> <p style="text-align: center;"><b>Support System C&amp;A</b></p> <ul style="list-style-type: none"> <li>• Identify DAA/Accreditor</li> <li>• Identify Certification Authority/Certifier</li> <li>• Identify C&amp;A and acquisition processes to be applied</li> <li>• Ensure Accreditor's and Certifier's concurrence                             <ul style="list-style-type: none"> <li>– System security context</li> <li>– Security CONOPS</li> <li>– System security requirements</li> </ul> </li> </ul>

<p><b>IEEE Std 1220-1998 Systems Engineering Process</b></p>	<p><b>ISSE Process</b></p>
<p><b>Functional Analysis</b></p> <ul style="list-style-type: none"> <li>• Functional context analysis                             <ul style="list-style-type: none"> <li>– Analyze functional behaviors</li> <li>– Define functional interfaces</li> <li>– Allocate performance requirements</li> </ul> </li> <li>• Functional decomposition                             <ul style="list-style-type: none"> <li>– Define subfunctions</li> <li>– Define subfunction states and modes</li> <li>– Define functional timelines</li> <li>– Define data and control flows</li> <li>– Define functional failure modes and effects</li> <li>– Define safety monitoring functions</li> </ul> </li> <li>• Establish functional architecture</li> </ul>	<p><b>Design System Security Architecture</b></p> <ul style="list-style-type: none"> <li>• Perform functional analysis and allocation                             <ul style="list-style-type: none"> <li>– Analyze candidate systems architectures</li> <li>– Allocate security services to architecture</li> <li>– Select mechanism types</li> <li>– Submit security architecture(s) for evaluation</li> <li>– Revise security architecture(s)</li> <li>– Select security architecture</li> </ul> </li> </ul>
<p><b>Functional Verification</b></p> <ul style="list-style-type: none"> <li>• Define verification procedures</li> <li>• Conduct verification evaluation                             <ul style="list-style-type: none"> <li>– Verify architecture completeness</li> <li>– Verify functional and performance measures</li> <li>– Verify satisfaction of constraints</li> </ul> </li> <li>• Identify variances and conflicts</li> <li>• Verified functional architecture</li> </ul>	<p><b>Assess Information Protection Effectiveness</b></p> <ul style="list-style-type: none"> <li>• Ensure that the selected security mechanisms provide the required security services</li> <li>• Explain to the customer how the security architecture meets the security requirements</li> <li>• Perform risk analysis</li> <li>• Obtain concurrence from the customer in the security architecture</li> </ul> <p><b>Support System C&amp;A</b></p> <ul style="list-style-type: none"> <li>• Prepare and submit final architecture documentation for risk analysis</li> <li>• Coordinate results with Accreditor and Certifier</li> </ul>
<p><b>Synthesis</b></p> <ul style="list-style-type: none"> <li>• Group and allocate functions</li> <li>• Identify design solution alternatives</li> <li>• Assess safety and environmental hazards</li> <li>• Assess life-cycle quality factors</li> <li>• Assess technology requirements</li> <li>• Define design and performance characteristics</li> <li>• Define physical interfaces</li> <li>• Identify standardization opportunities</li> <li>• Identify off-the-shelf availability</li> <li>• Identify make or buy alternatives</li> <li>• Develop models and fabricate prototypes</li> <li>• Assess failure modes, effects, and criticality</li> <li>• Assess testability needs</li> <li>• Assess design capacity to evolve</li> <li>• Final design</li> <li>• Initiate evolutionary development</li> <li>• Produce integrated data package</li> <li>• Establish design architecture</li> </ul>	<p><b>Develop Detailed Security Design</b></p> <ul style="list-style-type: none"> <li>• Ensure compliance with security architecture</li> <li>• Perform trade-off studies</li> <li>• Define system security design elements                             <ul style="list-style-type: none"> <li>– Allocate security mechanisms to system security design elements</li> <li>– Identify candidate COTS/GOTS security products</li> <li>– Identify custom security products</li> <li>– Qualify element and system interfaces (internal and external)</li> <li>– Develop specifications</li> </ul> </li> </ul>



<p align="center"><b>IEEE Std 1220-1998 Systems Engineering Process</b></p>	<p align="center"><b>ISSE Process</b></p>
<p align="center"><b>Design Verification</b></p> <ul style="list-style-type: none"> <li>• Select verification approach                             <ul style="list-style-type: none"> <li>– Define inspection, analysis, demonstration, or test requirements</li> <li>– Define verification procedures</li> <li>– Establish verification environment</li> <li>– Conduct verification evaluation</li> <li>– Verify architecture completeness</li> <li>– Verify functional and performance measures</li> <li>– Verify satisfaction of constraints</li> </ul> </li> <li>• Identify variance and conflicts</li> <li>• Verified design architecture</li> <li>• Verified design architectures of life-cycle processes</li> <li>• Verified system architecture</li> <li>• Establish specifications and configuration baselines</li> <li>• Develop product breakdown structures</li> </ul>	<p align="center"><b>Assess Information Protection Effectiveness</b></p> <ul style="list-style-type: none"> <li>• Conduct design risk analysis</li> <li>• Ensure that the selected security design provides the required security services</li> <li>• Explain to the customer how the security design meets the security requirements</li> <li>• Explain to the customer, and document, any residual risks of the design</li> <li>• Obtain concurrence from the customer in the detailed security design</li> </ul> <p align="center"><b>Support System C&amp;A</b></p> <ul style="list-style-type: none"> <li>• Prepare and submit detailed design documentation for risk analysis</li> <li>• Coordinate results with Accreditor and Certifier</li> </ul>
<p align="center"><b>System Analysis</b></p> <ul style="list-style-type: none"> <li>• Assess requirement conflicts</li> <li>• Assess functional alternatives</li> <li>• Assess design alternatives</li> <li>• Identify risk factors</li> <li>• Define trade study scope                             <ul style="list-style-type: none"> <li>– Select methodology and success criteria</li> <li>– Identify alternatives</li> <li>– Establish trade study environment</li> </ul> </li> <li>• Conduct trade study</li> <li>• Analyze life-cycle costs</li> <li>• Analyze system and cost-effectiveness</li> <li>• Analyze environmental impacts</li> <li>• Quantify risk factors</li> <li>• Select risk handling options</li> <li>• Select alternative recommendations</li> <li>• Design effectiveness assessment</li> <li>• Trade-offs and impacts</li> </ul>	<ul style="list-style-type: none"> <li>• System analysis is part of the risk assessment process, which also is part of the analysis performed in each activity. Therefore, the specific tasks are cited in the relative SEP subprocesses.</li> </ul>

<p><b>IEEE Std 1220-1998 Systems Engineering Process</b></p>	<p><b>ISSE Process</b></p>
<ul style="list-style-type: none"> <li>• The IEEE standard defines systems engineering as the total development effort and does not address implementation that would be addressed by manufacturing and test processes.</li> </ul>	<p style="text-align: center;"><b>Implement System Security</b></p> <ul style="list-style-type: none"> <li>• Support security implementation and integration                             <ul style="list-style-type: none"> <li>– Participate in implementation planning</li> <li>– Verify interoperability of security tools and mechanisms</li> <li>– Verify implementation against security design</li> <li>– Verify that the security components have been evaluated against the selected evaluation criteria (CCEP, NIAP, FIPS, or other NSA and NIST evaluation criteria)</li> <li>– Assist in the integration of the components to ensure that their integration meets the system security specifications and does not alter the component specifications</li> <li>– Assist in the configuration of the components to ensure that the security features are enabled and the security parameters are correctly set to provide the required security services</li> </ul> </li> <li>• Support test and evaluation                             <ul style="list-style-type: none"> <li>– Build test and evaluation strategy (includes demonstration, observation, analysis, and testing)</li> <li>– Assess available test and evaluation data for applicability (e.g., CCEP, NIAP, internal)</li> <li>– Support development of test and evaluation procedures</li> <li>– Support test and evaluation activities</li> </ul> </li> <li>• Support security training</li> </ul> <p style="text-align: center;"><b>Assess Information Protection Effectiveness</b></p> <ul style="list-style-type: none"> <li>• Monitor to ensure that the security design is implemented correctly</li> <li>• Conduct or update risk analysis</li> <li>• Define the risks and possible mission impacts and advise the customer and the customer’s Certifiers and Accreditors</li> </ul> <p style="text-align: center;"><b>Support C&amp;A</b></p> <ul style="list-style-type: none"> <li>• Ensure the completeness of the required C&amp;A documentation with the customer and the customer’s Certifiers and Accreditors</li> <li>• Provide documentation and analysis as required for the C&amp;A process</li> </ul>

IEEE Std 1220-1998 Systems Engineering Process	ISSE Process
<p style="text-align: center;"><b>Control</b></p> <ul style="list-style-type: none"> <li>• Technical management                             <ul style="list-style-type: none"> <li>– Data management</li> <li>– Configuration management</li> <li>– Interface management</li> <li>– Risk management</li> <li>– Performance-based progress measurements</li> </ul> </li> <li>• Track system analysis, and verification and test data</li> <li>• Track requirements and design changes</li> <li>• Track performance against project plans</li> <li>• Track performance against technical plans</li> <li>• Track product and process metrics</li> <li>• Update specifications and configuration baselines</li> <li>• Update requirement views and architectures</li> <li>• Update engineering plans</li> <li>• Update technical plans</li> <li>• Integrated database</li> </ul>	<p style="text-align: center;"><b>Plan Technical Effort</b></p> <ul style="list-style-type: none"> <li>• Estimate project scope</li> <li>• Identify resources and availability</li> <li>• Identify roles and responsibilities</li> <li>• Estimate project costs</li> <li>• Develop project schedule</li> <li>• Identify technical activities</li> <li>• Identify deliverables</li> <li>• Define management interfaces</li> <li>• Prepare technical management plan</li> <li>• Review project plan</li> <li>• Obtain customer agreement</li> </ul> <p style="text-align: center;"><b>Manage Technical Effort</b></p> <ul style="list-style-type: none"> <li>• Direct technical effort</li> <li>• Track project resources</li> <li>• Track technical parameters</li> <li>• Monitor progress of technical activities</li> <li>• Ensure quality of deliverables</li> <li>• Manage configuration elements</li> <li>• Review project performance</li> <li>• Report project status</li> </ul>